

**TYPICAL UNCASSED ROAD/RAILROAD CROSSING  
OPEN CUT OR BORED**

BORE ANNULUS SHALL BE NO MORE THAN 1" GREATER THAN THE CONCRETE COATED PIPE AND INSULATION/COATING.

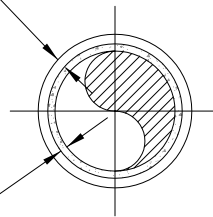

1" CONCRETE COATING OR 80 MILS OF POWERCRETE

**SECTION A-A**

- CROSSINGS SHALL BE IN ACCORDANCE WITH APPLICABLE PERMITS AND REGULATIONS.
- ROAD CROSSING PIPE SHALL EXTEND TO A MINIMUM OF RIGHT OF WAY LINE.
- TYPE AND MINIMUM LENGTH REQUIRED FOR CROSSINGS OF PUBLIC ROADS SHALL BE SPECIFIED ON ALIGNMENT SHEETS.

REVISIONS						
NO.	DESCRIPTION	BY	DATE	CHK	DATE	APR
A	-	-	-	-	-	-

**TYPICAL CONSTRUCTION DETAIL**

UNCASSED ROAD CROSSING  
BORED OR OPEN CUT

SCALE: NONE

DWG. NUMBER: **STD-C002**

REV: A

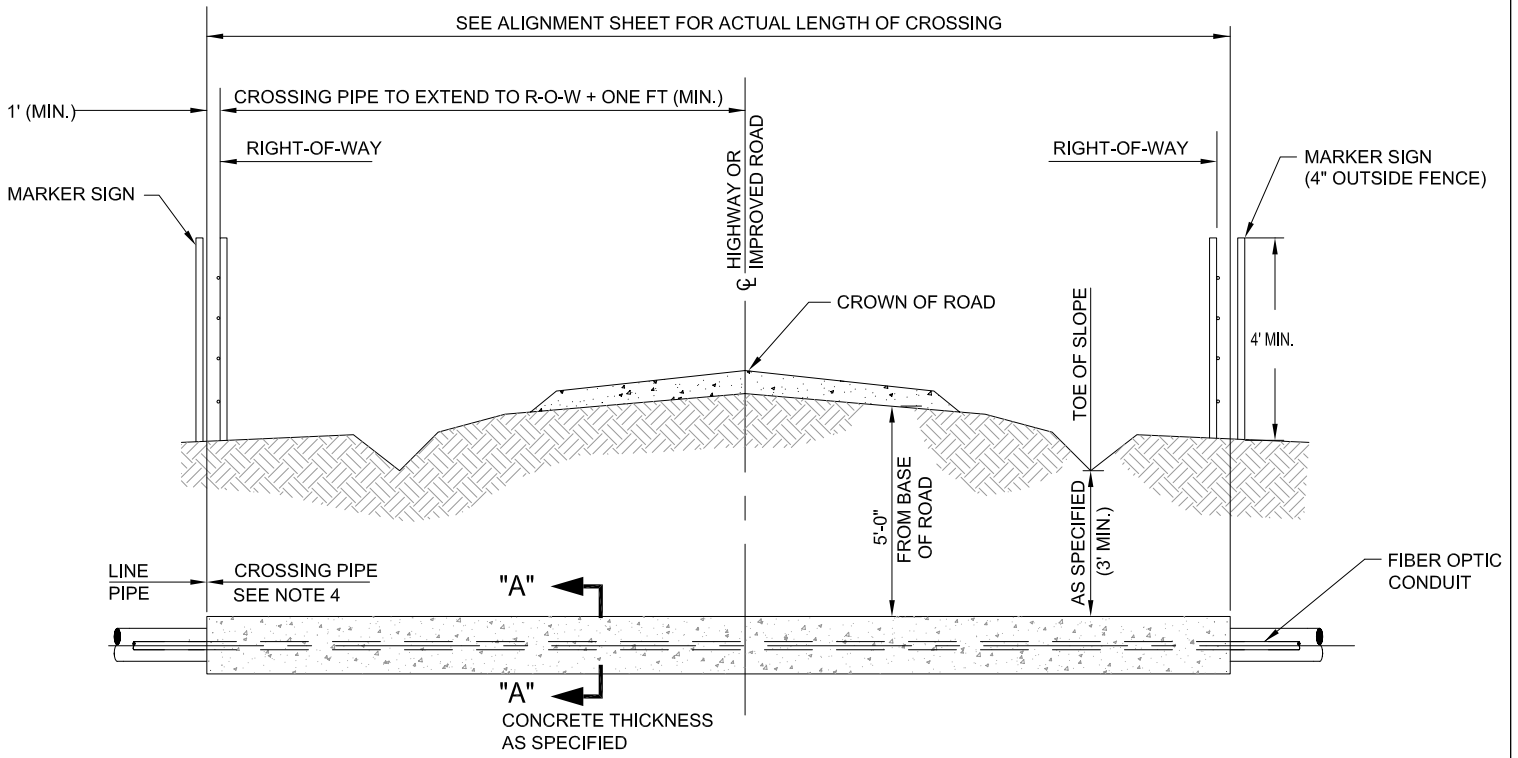

**TYPICAL ROAD CROSSING  
SLICK BORED**

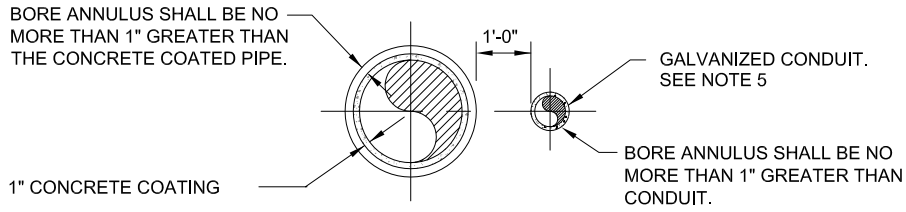

**SECTION A-A**

**NOTES:**

1. CROSSINGS SHALL BE IN ACCORDANCE WITH APPLICABLE PERMITS AND REGULATIONS.
2. ROAD CROSSING PIPE SHALL EXTEND AT MINIMUM TO ONE FOOT OUTSIDE OF R-O-W LINE OR TO A POINT INDICATED ON THE PIPELINE ALIGNMENT SHEET.
3. TYPE AND MINIMUM LENGTH REQUIRED FOR CROSSINGS OF PUBLIC ROADS SHALL BE SPECIFIED ON ALIGNMENT SHEETS.
4. ALL BORED CROSSING PIPE SHALL HAVE A MINIMUM OF ONE INCH CONCRETE COATING FOR PROTECTION DURING INSERTION.
5. FIBER OPTIC CONDUIT DOES NOT REQUIRE CONCRETE COATING.

REVISIONS						
NO.	DESCRIPTION	BY	DATE	CHK	DATE	APR
A	-	-	-	-	-	-

<b>TYPICAL CONSTRUCTION DETAIL</b>		
PIPELINE & FIBER CONSTRUCTION DETAIL UNCASED ROAD CROSSING SLICK BORED		
SCALE: NONE	DWG. NUMBER: <b>STD-C003</b>	REV: <b>A</b>

Plot Date: 7/13/2009 11:30:11 AM Plot By: Chuck Haas File Name: D:\000000000000000000\lane\frantz\Std-C003.dwg

Plot Date: 7/13/2009 11:10:54 AM Plot By: Chuck Haas File Name: D:\00000000000000000000\lane\frantz\Std-C004.dwg

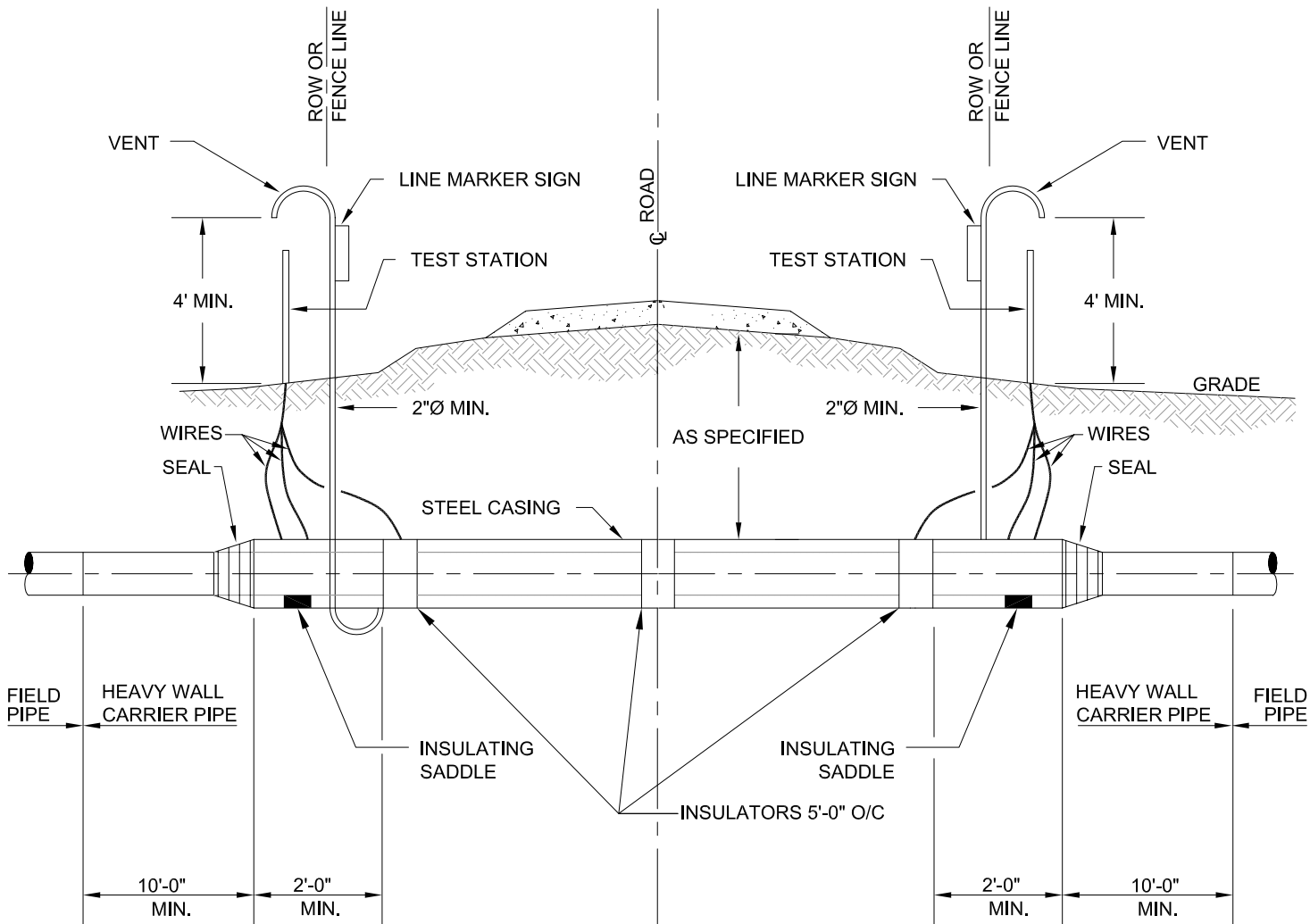

### TYPICAL CASING FOR ROAD CROSSING

**NOTES:**

1. CROSSINGS SHALL BE IN ACCORDANCE WITH APPLICABLE PERMITS.
2. MATERIAL REQUIRED FOR CROSSINGS SHALL BE SPECIFIED ON ALIGNMENT SHEETS.

REVISIONS						
NO.	DESCRIPTION	BY	DATE	CHK	DATE	APR

TYPICAL CONSTRUCTION DETAIL		
PIPELINE SPECIFICATION CASED ROAD CROSSING		
SCALE: NONE	DWG. NUMBER: <b>STD-C004</b>	REV: <b>A</b>

Plot Date: 7/13/2009 11:32:15 AM Plot By: Chuck Haas File Name: D:\00000000000000000000\lane\frantz\Std-C008.dwg

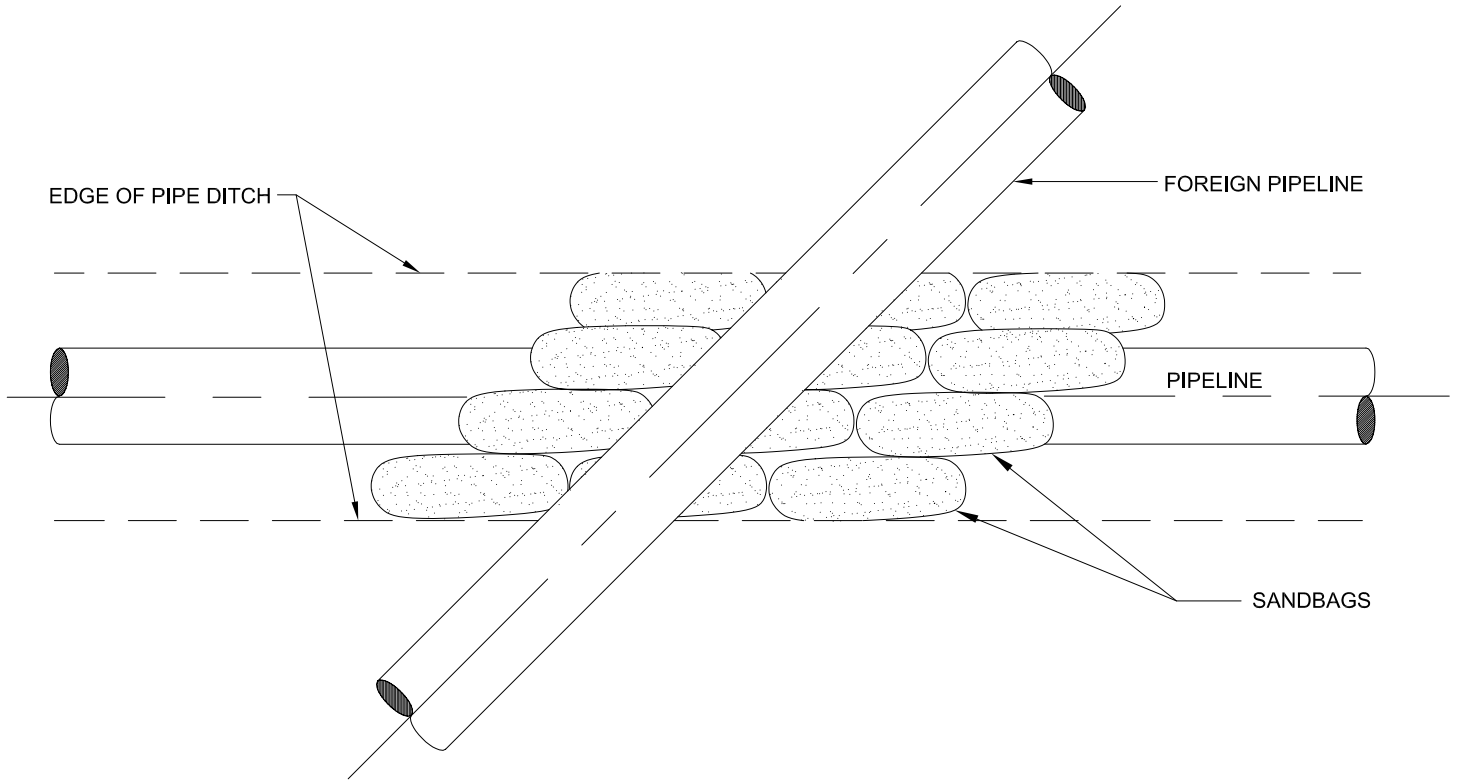

**PLAN**

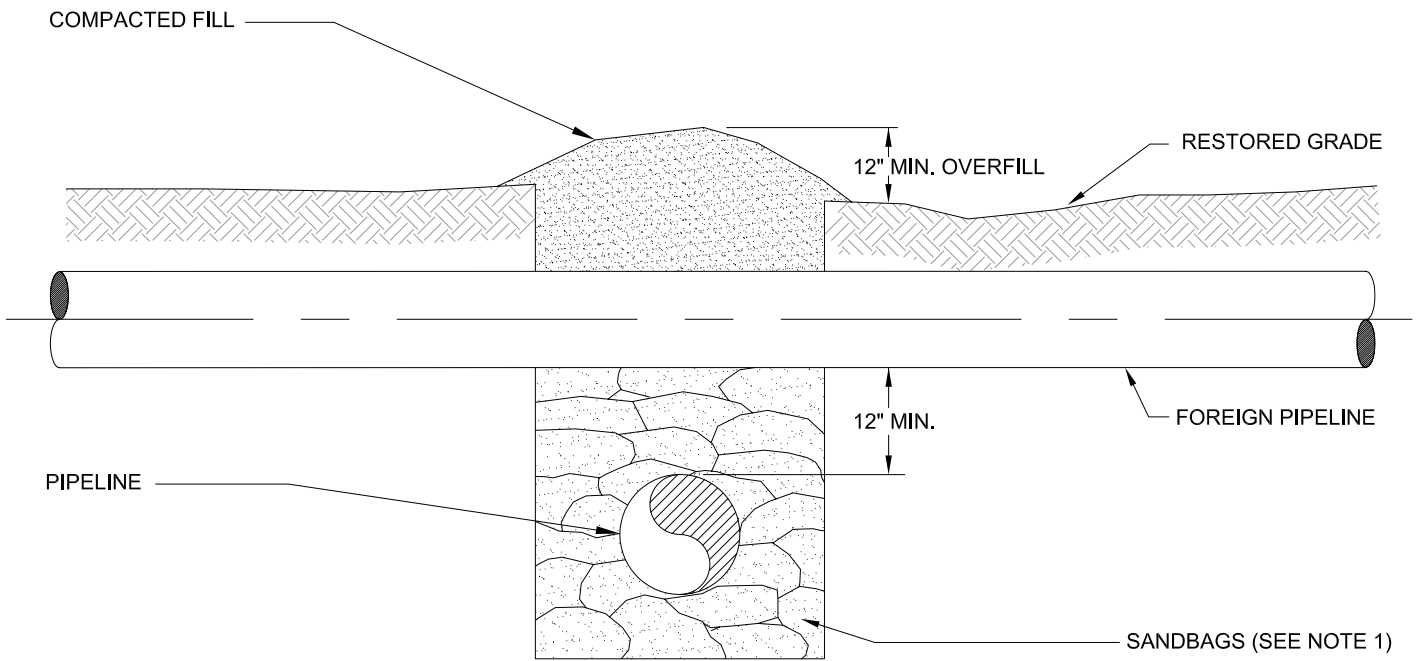

**ELEVATION**

**NOTES:**

- 1) SANDBAGS OR FOAM SUPPORTS SHALL BE INSTALLED AS INDICATED IN ALL AREAS WHERE SUPPLY BACKFILL IS NOT USED.

REVISIONS								TYPICAL CONSTRUCTION DETAIL		
NO.	DESCRIPTION	BY	DATE	CHK	DATE	APR	DATE	FOREIGN LINE PIPELINE CROSSING		
A	-	-	-	-	-	-	-	SCALE: NONE	DWG. NUMBER: <b>STD-C008</b>	REV: <b>A</b>

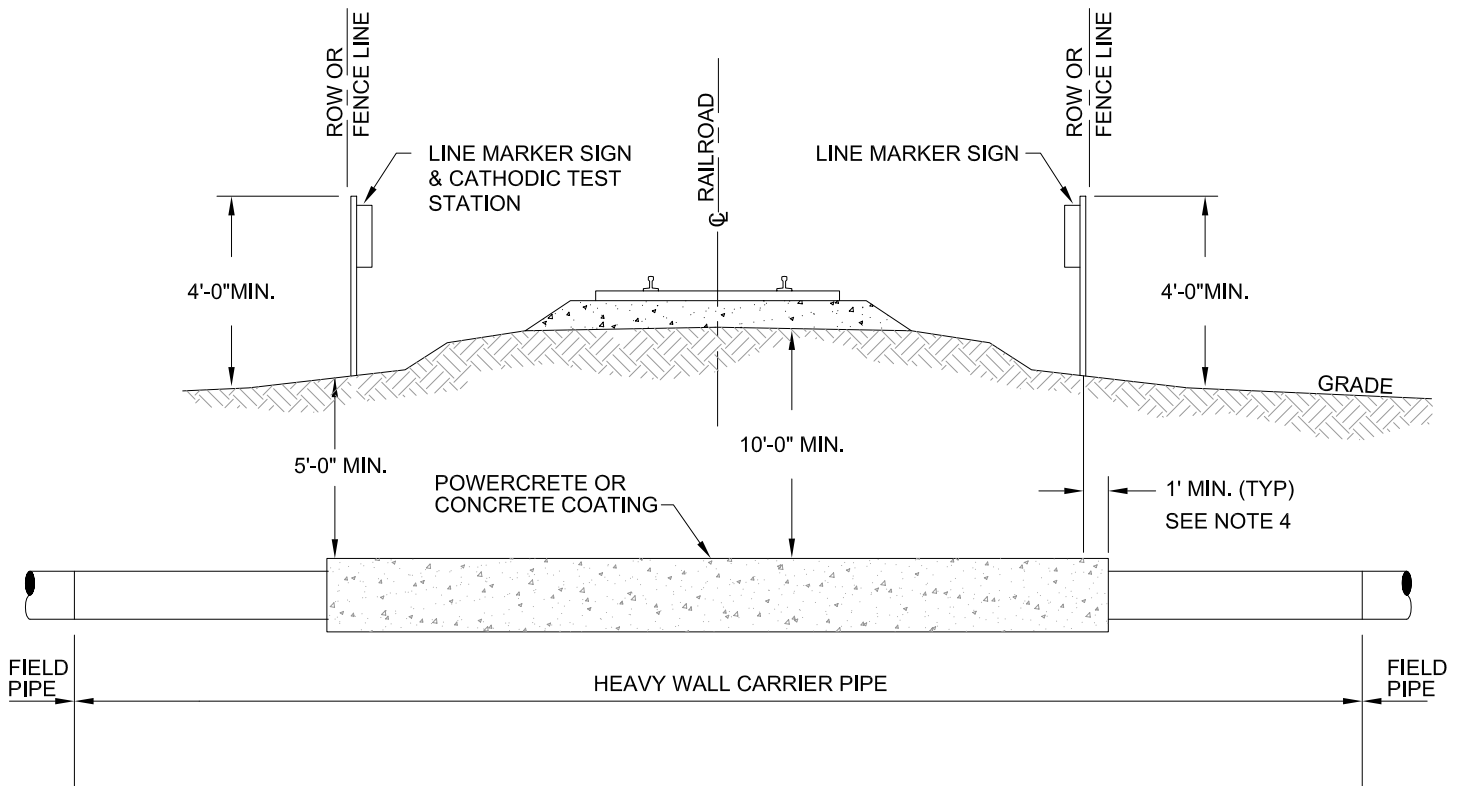

### TYPICAL UNCASSED SLICK BORED RAILROAD SPUR CROSSING

**NOTES:**

- 1) CROSSINGS SHALL BE IN ACCORDANCE WITH APPLICABLE PERMIT.
- 2) CARRIER PIPE TO BE FACTORY COATED.
- 3) MINIMUM BURIAL DEPTH WITHIN THE RAILROAD R-O-W IS 5'-0" FROM GRADE TO TOP OF PIPE.
- 4) RAILROAD CROSSING PIPE SHALL EXTEND A MINIMUM ONE FOOT OUTSIDE THE R-O-W LINE OR TO A POINT INDICATED ON THE ALIGNMENT SHEET.
- 5) THE TYPE AND MINIMUM REQUIRED LENGTH OF PIPE FOR CROSSINGS OF RAILROAD SHALL BE AS SPECIFIED ON THE ALIGNMENT SHEETS.
- 6) ALL BORED CROSSING PIPE SHALL HAVE A MINIMUM OF ONE INCH CONCRETE COATING, OR 80 MILS POWERCRETE FOR PROTECTION DURING INSERTION.

Plot Date: 7/13/2009 11:34:12 AM Plot By: Chuck Haas File Name: D:\00000000000000000000\lanefrantz\Std-C009.dwg

REVISIONS							TYPICAL CONSTRUCTION DETAIL			
NO.	DESCRIPTION	BY	DATE	CHK	DATE	APR	DATE	PIPELINE SPECIFICATION UNCASSED / BORED RAILROAD SPUR CROSSING		
								SCALE: NONE	DWG. NUMBER: <b>STD-C009</b>	REV: <b>A</b>

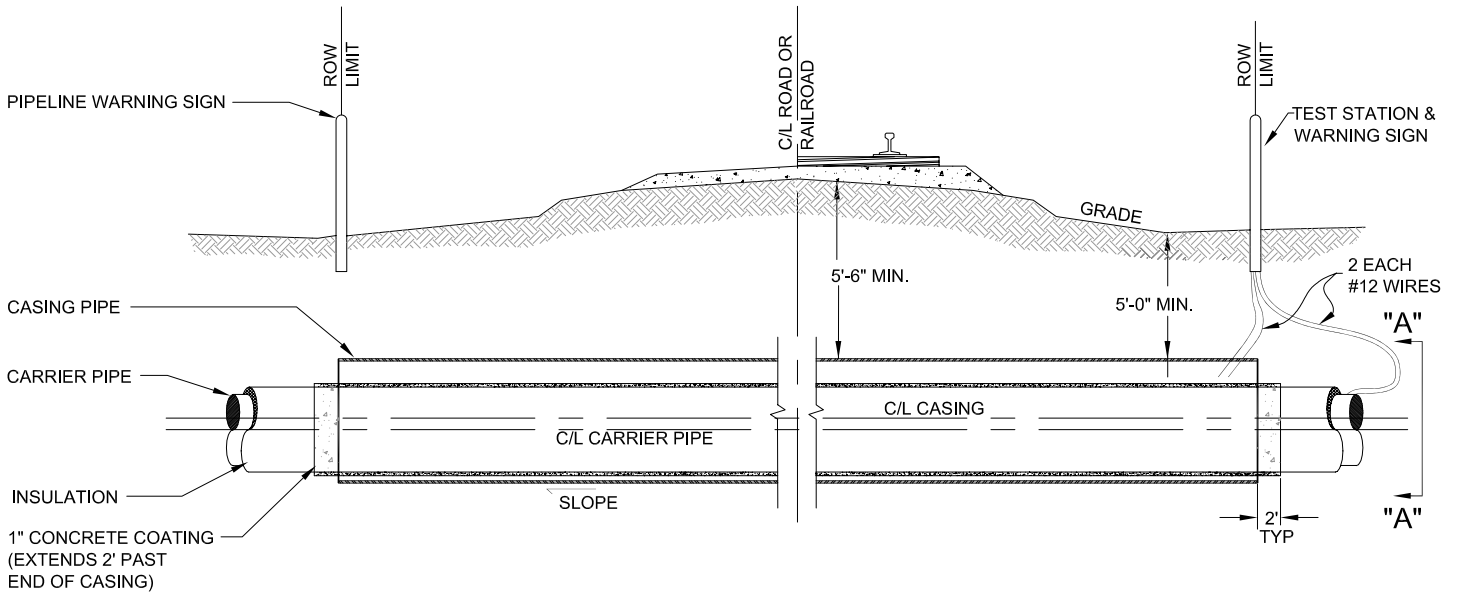

**TYPICAL CASED CROSSING-SINGLE CARRIER PIPELINE  
TYPICAL INSULATED PIPE**

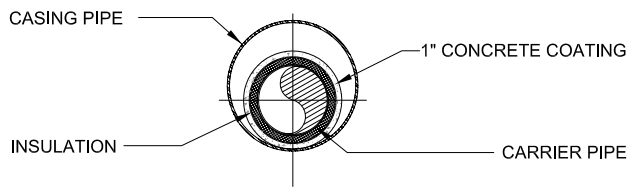

**SECTION 'A'**

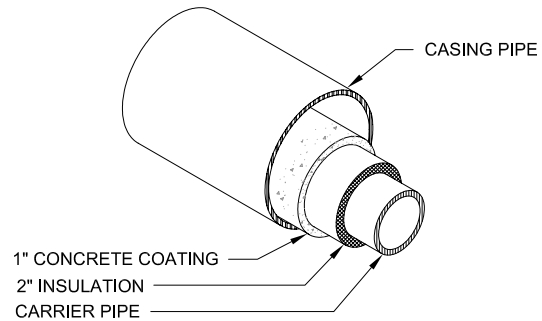

**ISOMETRIC VIEW**

**NOTES:**

1. CARRIER PIPE SHALL BE FACTORY COATED.
2. MINIMUM BURIAL DEPTH WITHIN R-O-W IS 5'-0" FROM GRADE TO TOP OF PIPE.
3. DITCH TO BE COMPACTED UNDER THE CARRIER PIPE FOR 25' FROM END OF CASING.

CARRIER DIA.	CASING DIA.	CASING W.T.
26"	30"	.500

Plot Date: 7/13/2009 11:52:45 AM Plot By: Chuck Haas File Name: D:\000000000000000000\lanefranzi\Std-C013.dwg

REVISIONS						
NO.	DESCRIPTION	BY	DATE	CHK	DATE	APR

TYPICAL CONSTRUCTION DETAIL		
CASED CROSSING SINGLE CARRIER PIPELINE DETAIL		
SCALE: NONE	DWG. NUMBER: <b>STD-C013</b>	REV: <b>A</b>

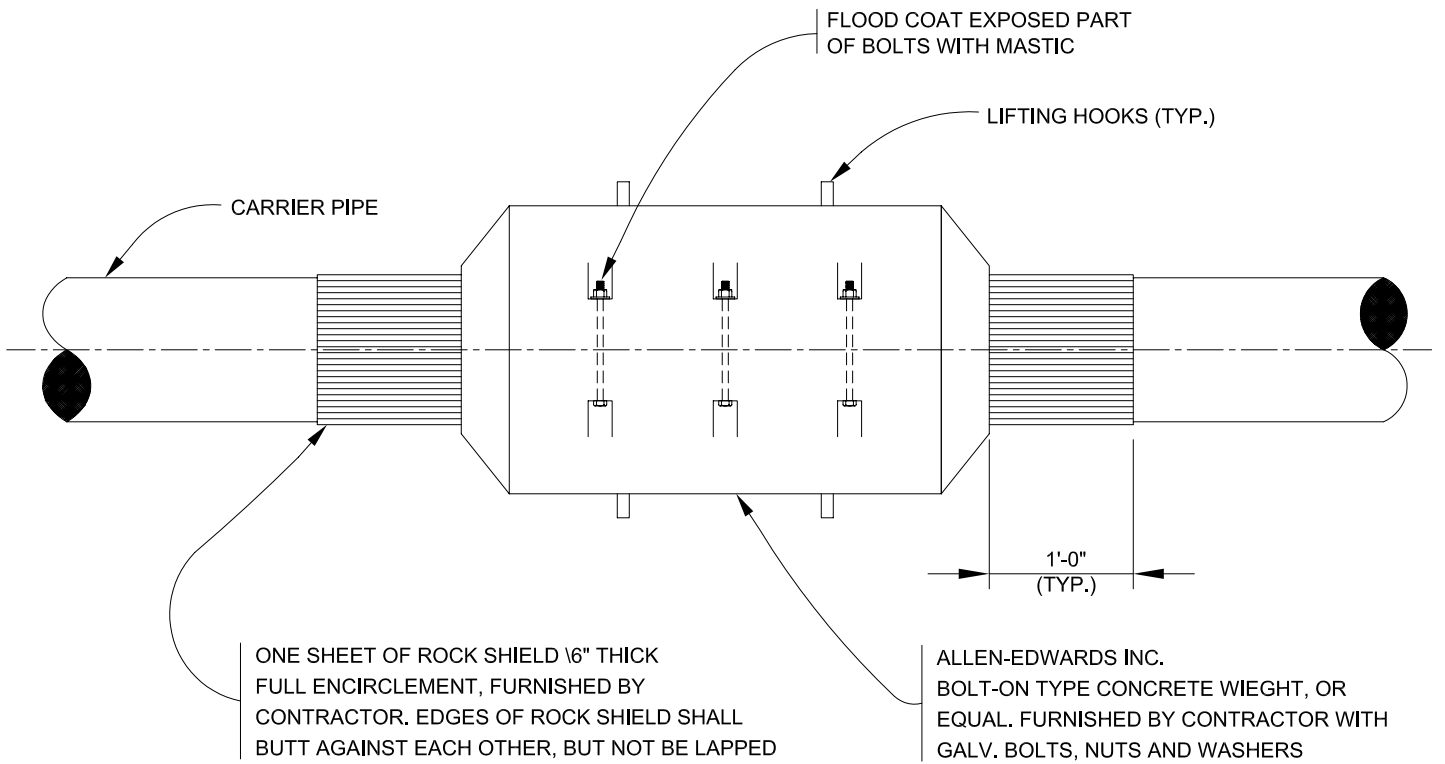

GENERAL SPACING REQUIREMENTS OF FULL BOLT-ON WEIGHTS - SEE NOTES 1 AND 2						
PIPE SIZE O.D. x W.T.	APPROX. WEIGHT IN AIR (LBS)	REQUIRED SPACING C-C		DIMENSIONS		
		IN SWAMPS 1.2 S.G.	IN RIVERS 1.3 S.G. + 10#/FT	NOM. PIPE SIZE	LENGTH	DIAMETER
10.75" x .365	1085	35'	28'	10.75"	5'	20"
12.75" x .375	1570	28'	20'	12.75"	5'	24"

**NOTES:**

1. ABOVE TABLES PREPARED USING 140 POUND PER CUBIC FOOT CONCRETE. IF OTHER SIZES AND/OR WEIGHTS OF CONCRETE WEIGHTS ARE FURNISHED, SPACING SHALL BE ADJUSTED TO MAINTAIN THE SPECIFIED NEGATIVE BUOYANCY.
2. INSTALL FULL BOLT-ON OR HALF BOLT-ON WEIGHTS AT LOCATIONS SHOWN ON DRAWINGS AND/OR AS DESIGNATED BY COMPANY.
3. WEIGHTS SHALL BE CABLED FROM ONE TO THE OTHER WITH 1/4" STEEL CABLE TO PREVENT SLIPPAGE OF WEIGHTS DURING INSTALLATION. CABLE AND CLAMPS SHALL BE FURNISHED BY CONTRACTOR.

REVISIONS							
NO.	DESCRIPTION	BY	DATE	CHK	DATE	APR	DATE

TYPICAL CONSTRUCTION DETAIL	
TYPICAL BOLT-ON CONCRETE WEIGHTS	
SCALE: NONE	DWG. NUMBER: <b>STD-C023</b> REV: A



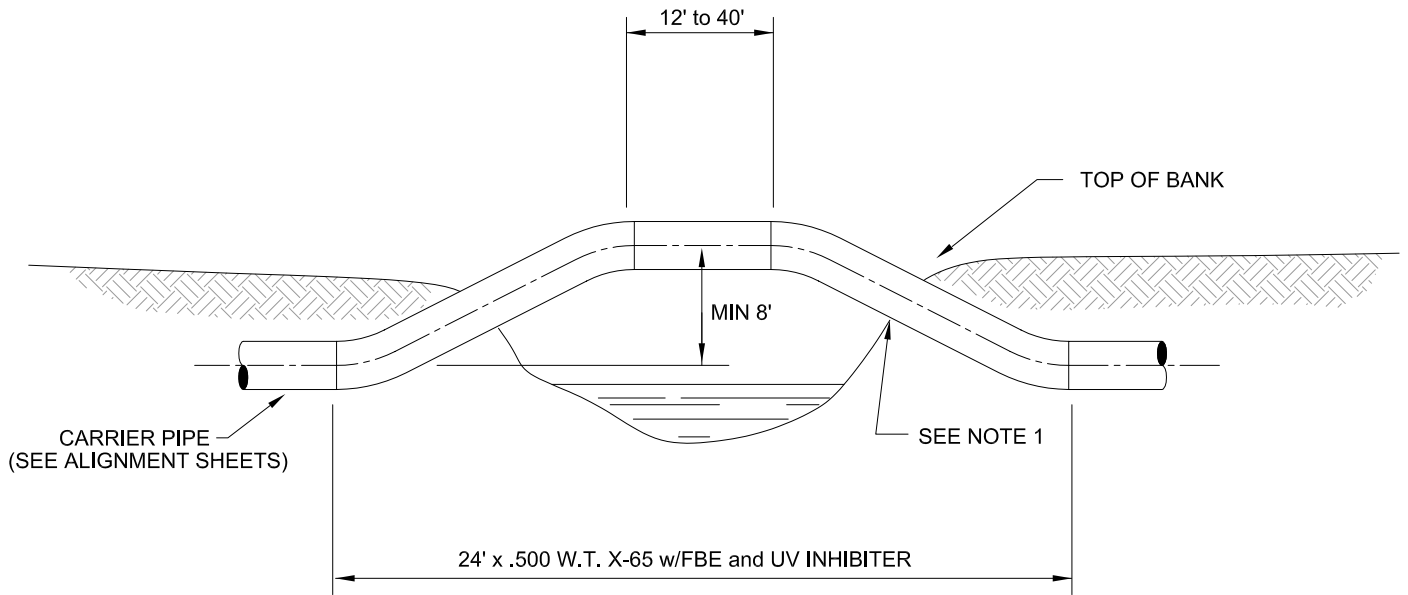

**NOTES:**

1. MAXIMUM OF 3' OF BANK DISTURBANCE FROM TOP OF BANK.

Plot Date: 7/13/2009 11:57:09 AM Plot By: Chuck Haas File Name: D:\0000000000000000\lanefrantz\Std-C025.dwg

REVISIONS							
NO.	DESCRIPTION	BY	DATE	CHK	DATE	APR	DATE
A	-	-	-	-	-	-	-

TYPICAL CONSTRUCTION DETAIL		
SPANNED CANAL OR STREAM CROSSING		
SCALE: NONE	DWG. NUMBER: <b>STD-C025</b>	REV: <b>A</b>

Plot Date: 7/13/2009 11:58:06 AM Plot By: Chuck Haas File Name: D:\0000000000000000\lane\frantz\Std-C026.dwg

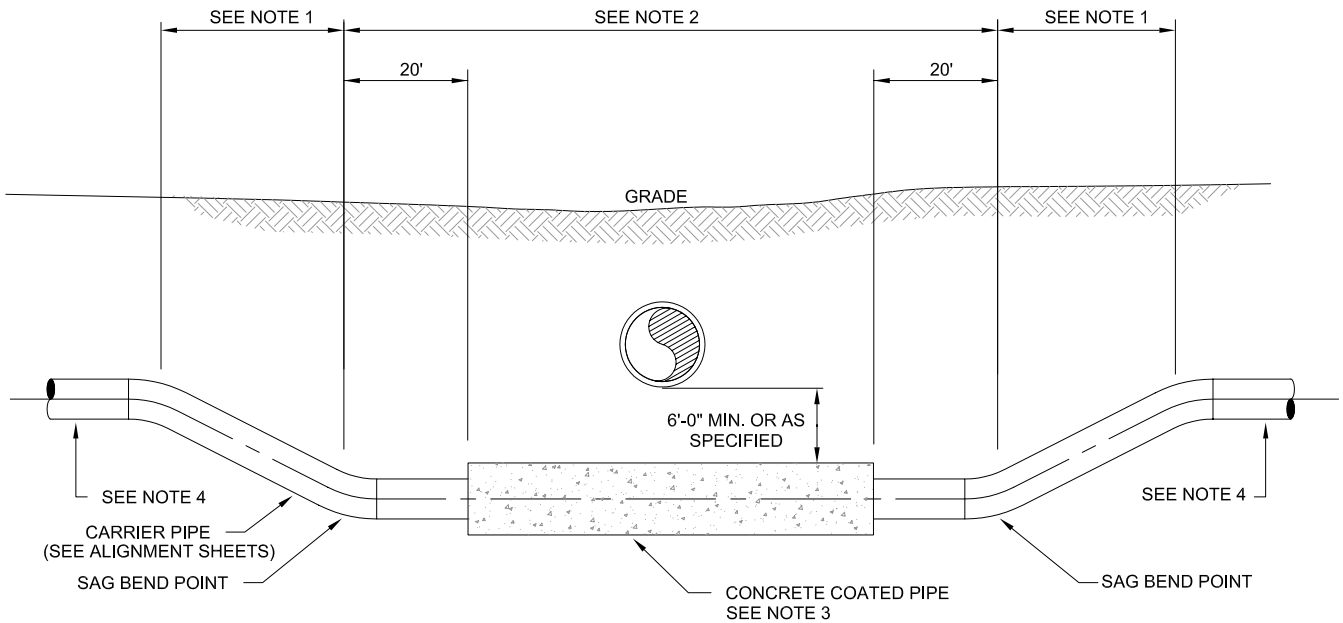

**NOTES:**

1. PIPE SHALL BE GRADUALLY LOWERED TO PREVENT EXCESSIVE BENDING.
2. PIPE SHALL BE LEVEL UNDER STREAM CHANNEL TO THE DEPTH SHOWN OR AS SPECIFIED.
3. CONTRACTOR SHALL INSTALL CONCRETE COATED PIPE AS SPECIFIED.
4. PIPE ENDS AT TANGENTS SHALL BE PREPARED AS NOTED IN ACCORDANCE WITH DOT & ANSI REGULATIONS.
5. CONTRACTOR SHALL WRAP AND CONCRETE COAT WELD JOINTS.

REVISIONS							
NO.	DESCRIPTION	BY	DATE	CHK	DATE	APR	DATE
A	-	-	-	-	-	-	-

**TYPICAL CONSTRUCTION DETAIL**

CONCRETE COATED CANAL  
CULVERT CROSSING

SCALE: NONE

DWG. NUMBER: **STD-C026**

REV: **A**

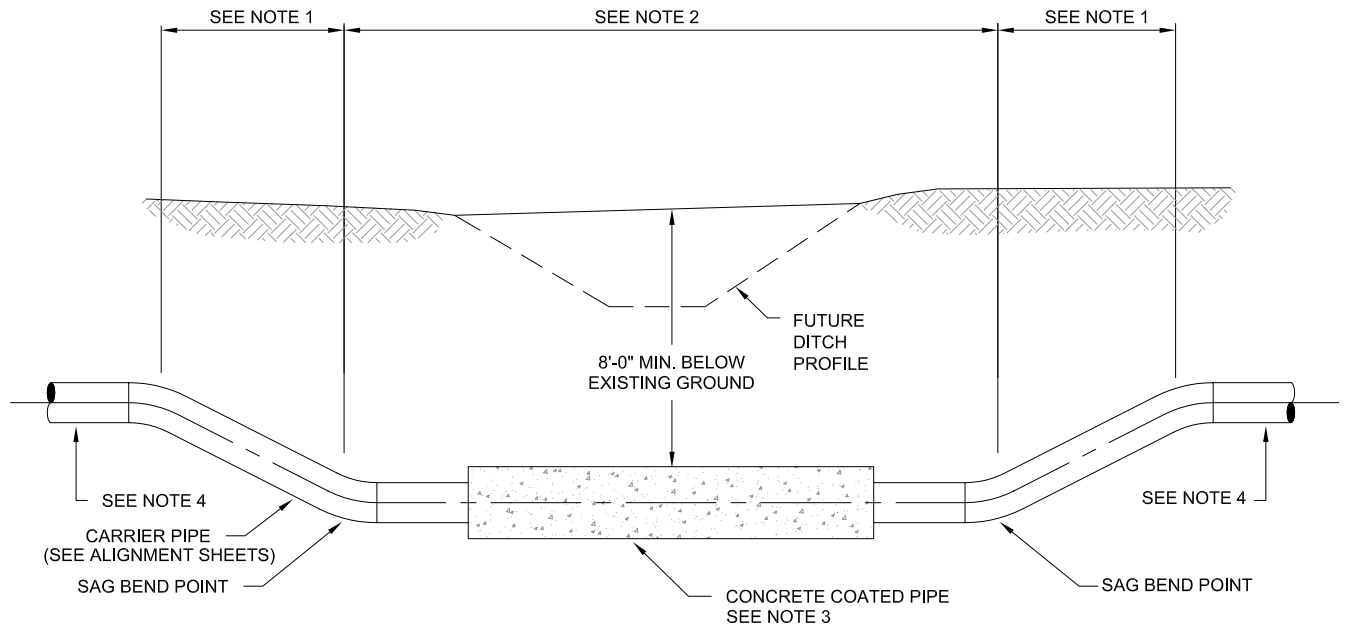

**NOTES:**

1. PIPE SHALL BE GRADUALLY LOWERED TO PREVENT EXCESSIVE BENDING.
2. PIPE SHALL BE LEVEL UNDER STREAM CHANNEL TO THE DEPTH SHOWN OR AS SPECIFIED.
3. CONTRACTOR SHALL INSTALL CONCRETE COATED PIPE AS SPECIFIED.
4. PIPE ENDS AT TANGENTS SHALL BE PREPARED AS NOTED IN ACCORDANCE WITH DOT & ANSI REGULATIONS.
5. CONTRACTOR SHALL WRAP AND CONCRETE COAT WELD JOINTS.

Plot Date: 7/13/2009 11:59:11 AM Plot By: Chuck Haas File Name: D:\000000000000000000\lane\frantz\Std-C029.dwg

REVISIONS							
NO.	DESCRIPTION	BY	DATE	CHK	DATE	APR	DATE
A	-	-	-	-	-	-	-

<b>TYPICAL CONSTRUCTION DETAIL</b>	
CONCRETE COATED FOR FUTURE DITCH CROSSING	
SCALE: NONE	DWG. NUMBER: <b>STD-C029</b> REV: <b>A</b>

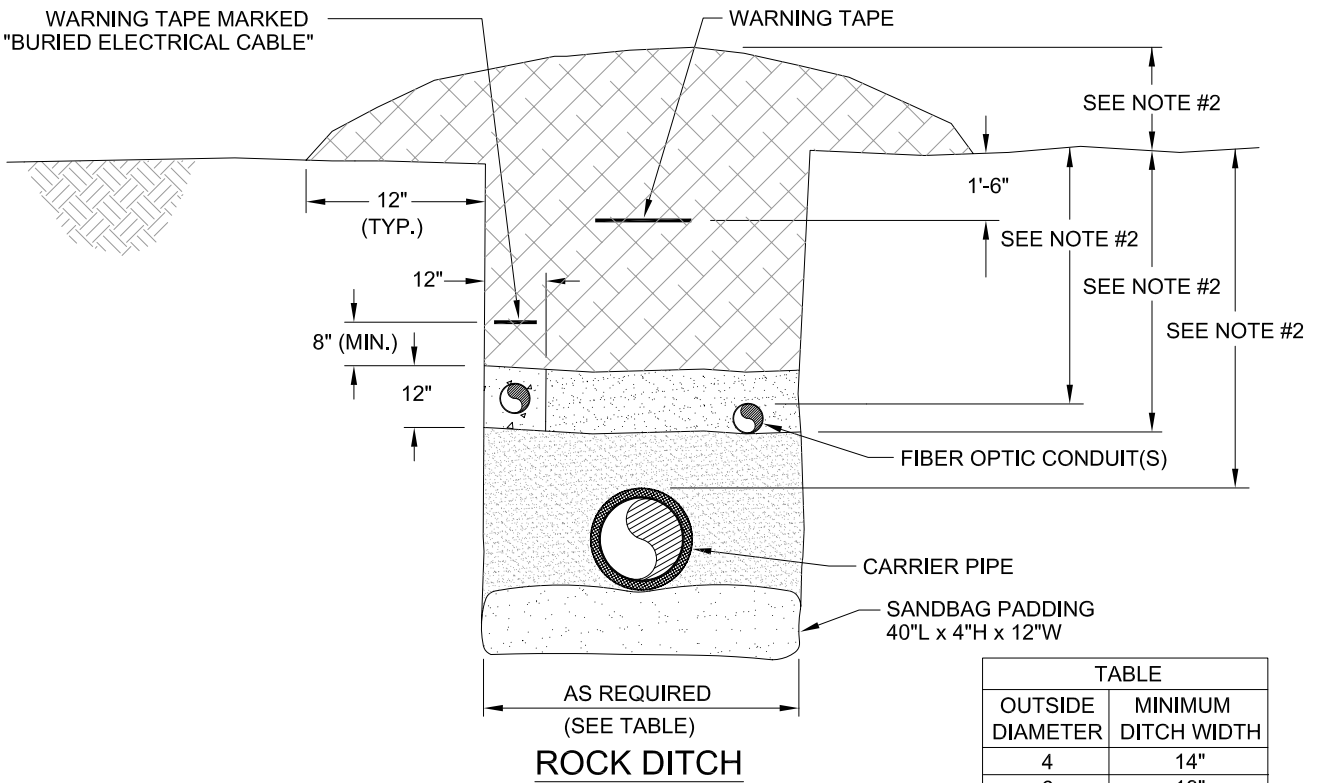
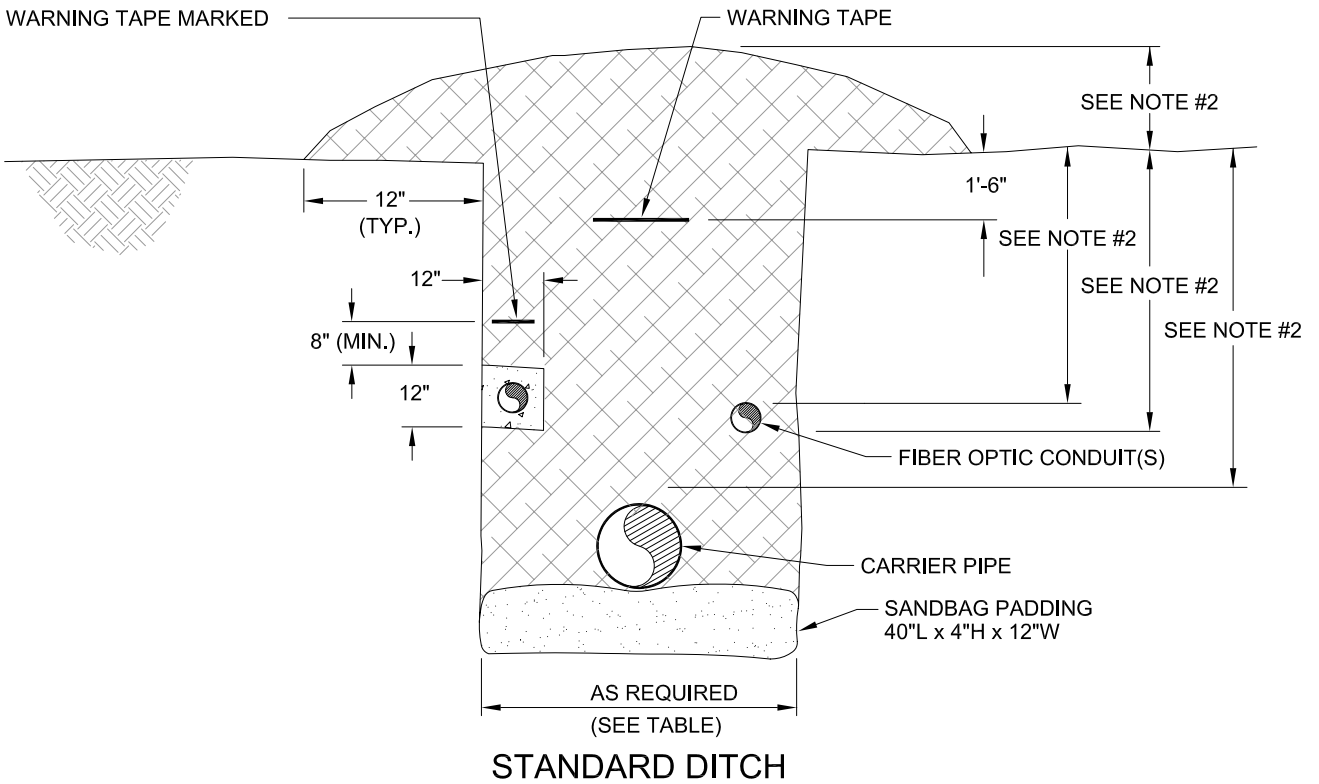

**NOTES:**

1. SEE CONSTRUCTION DOCUMENTS FOR PADDING REQUIREMENTS UNDER PIPE.
2. SEE CONSTRUCTION DOCUMENTS AND DRAWINGS FOR ALL BACKFILL DIMENSIONS.
3. BERMS SHALL NOT BE INSTALLED IN THE RAILROAD R/W.

TABLE	
OUTSIDE DIAMETER	MINIMUM DITCH WIDTH
4	14"
6	18"
8	20"
10	24"
12	24"
20	36"
22	36"
24	36"

REVISIONS						
NO.	DESCRIPTION	BY	DATE	CHK	DATE	APR
A	-	-	-	-	-	-

TYPICAL CONSTRUCTION DETAIL		
CROSS-COUNTRY AND R.R. R-O-W CONSTRUCTION STANDARD SINGLE DITCH DIMENSION FOR CARRIER PIPE WITH FIBER OPTIC CONDUIT/S		
SCALE: NONE	DWG. NUMBER: <b>STD-D000</b>	REV: <b>A</b>

Plot Date: 7/13/2009 12:00:56 PM Plot By: Chuck Haas File Name: D:\0000000000000000\lane\frantz\Std-D000.dwg

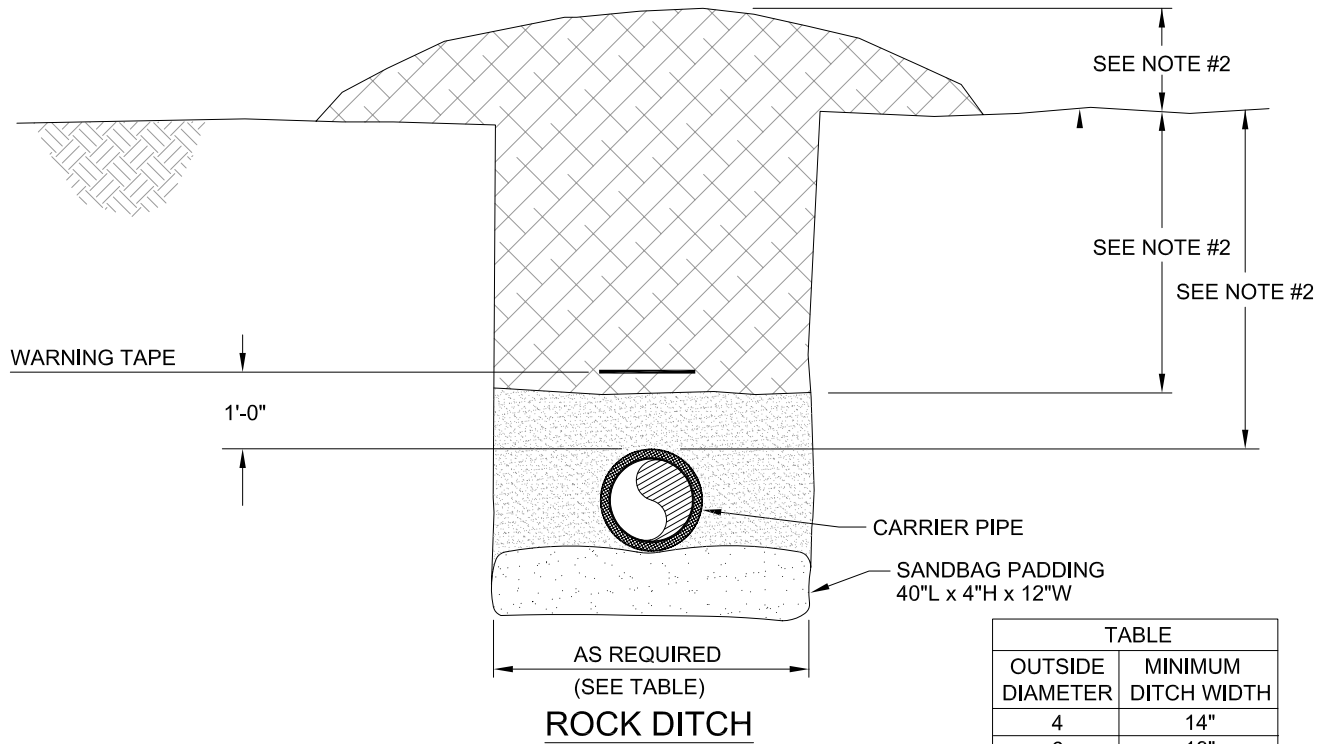
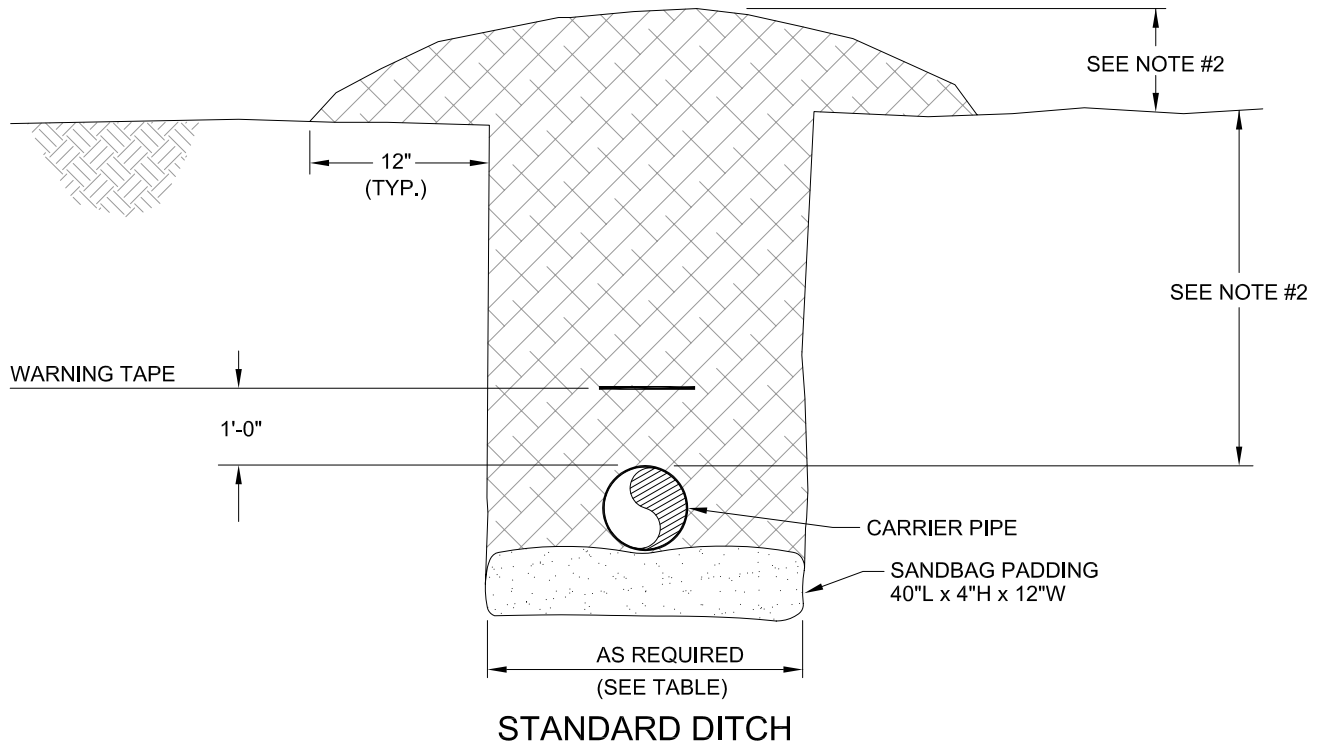

**NOTES:**

1. SEE CONSTRUCTION DOCUMENTS FOR PADDING REQUIREMENTS UNDER PIPE.
2. SEE CONSTRUCTION DOCUMENTS AND DRAWINGS FOR ALL BACKFILL DIMENSIONS.
3. BERMS SHALL NOT BE INSTALLED IN THE RAILROAD R/W.

TABLE	
OUTSIDE DIAMETER	MINIMUM DITCH WIDTH
4	14"
6	18"
8	20"
10	24"
12	24"
20	36"
22	36"
24	36"

Plot Date: 7/13/2009 12:02:37 PM Plot By: Chuck Haas File Name: D:\0000000000000000\lane\frantz\Std-D001.dwg

REVISIONS							
NO.	DESCRIPTION	BY	DATE	CHK	DATE	APR	DATE
A	-	-	-	-	-	-	-

TYPICAL CONSTRUCTION DETAIL		
CROSS-COUNTRY AND R.R. R-O-W CONSTRUCTION STANDARD SINGLE DITCH DIMENSION FOR CARRIER PIPE		
SCALE: NONE	DWG. NUMBER: <b>STD-D001</b>	REV: <b>A</b>

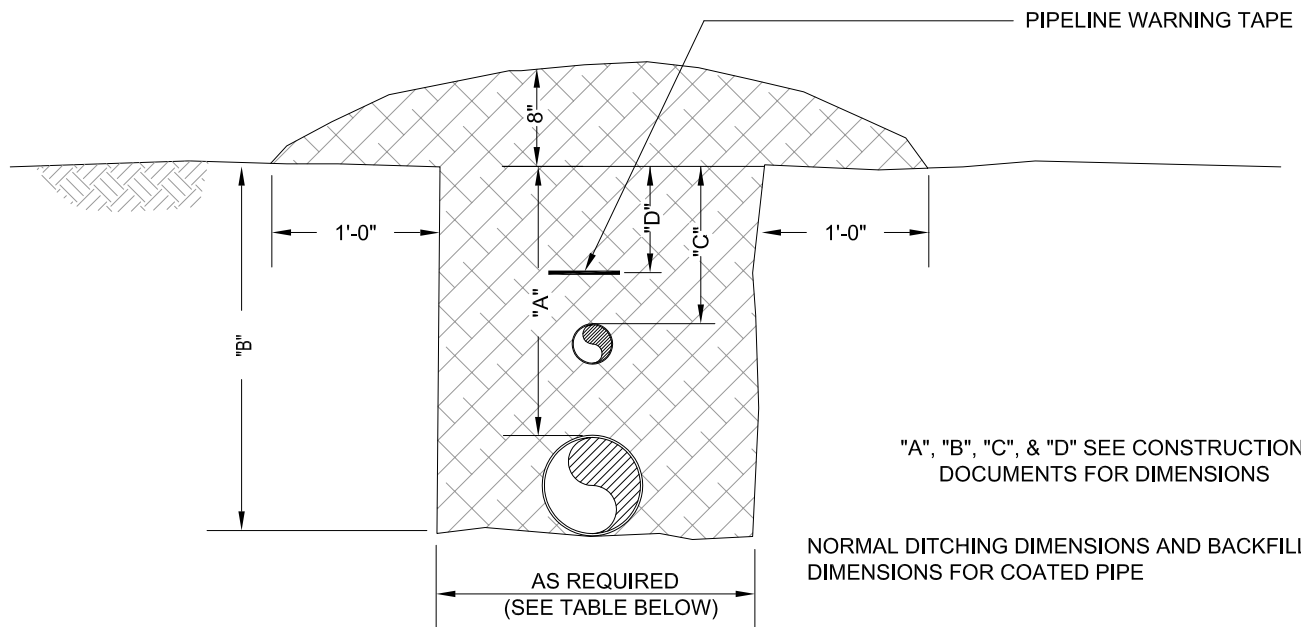

**STANDARD DITCH**

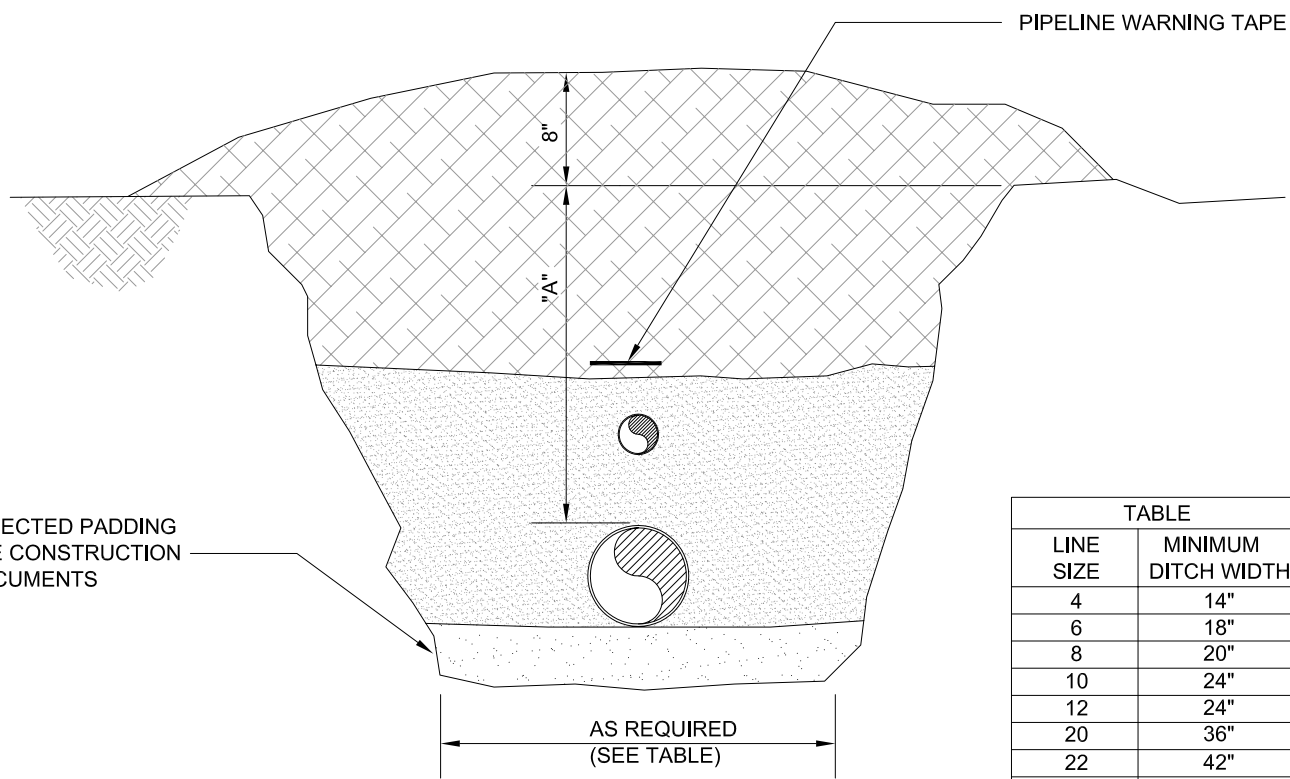

**ROCK DITCH**

TABLE	
LINE SIZE	MINIMUM DITCH WIDTH
4	14"
6	18"
8	20"
10	24"
12	24"
20	36"
22	42"
24	48"

Plot Date: 7/13/2009 12:03:41 PM Plot By: Chuck Haas File Name: D:\000000000000000000\lane\frantz\Std-D002.dwg

REVISIONS							
NO.	DESCRIPTION	BY	DATE	CHK	DATE	APR	DATE
A	-	-	-	-	-	-	-

TYPICAL CONSTRUCTION DETAIL		
STANDARD DITCH DIMENSIONS FOR DUAL LINES IN DITCH		
SCALE: NONE	DWG. NUMBER: <b>STD-D002</b>	REV: <b>A</b>

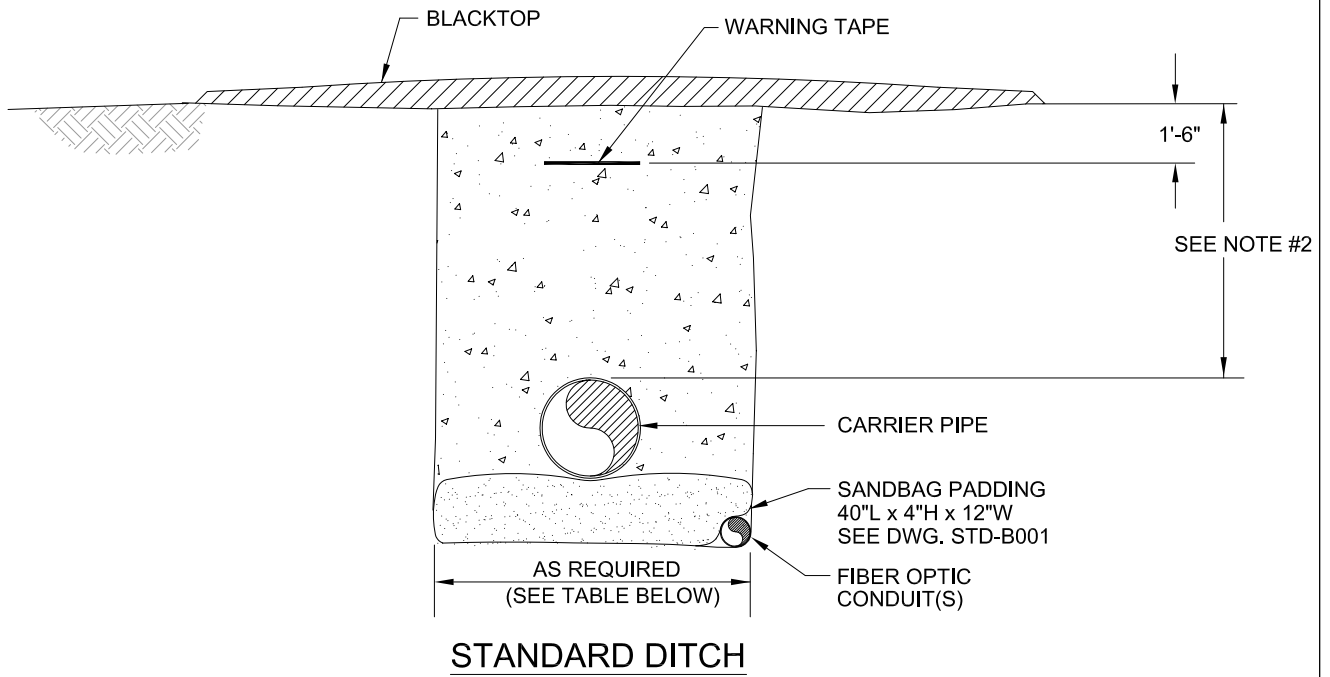

**STANDARD DITCH**

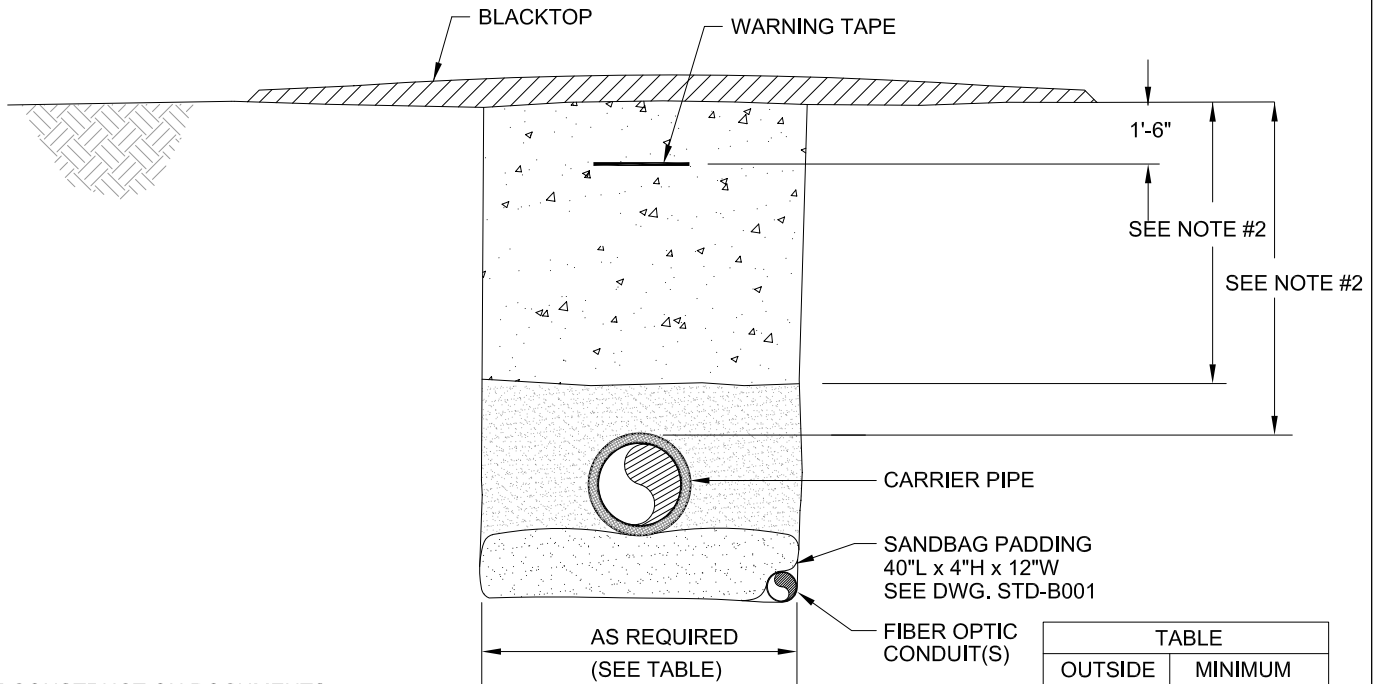

**ROCK DITCH**

**NOTES:**

- 1) SEE CONSTRUCTION DOCUMENTS FOR PADDING REQUIREMENTS UNDER PIPE.
- 2) SEE CONSTRUCTION DOCUMENTS AND DRAWINGS FOR ALL BACKFILL DIMENSIONS.

TABLE	
OUTSIDE DIAMETER	MINIMUM DITCH WIDTH
4	14"
6	18"
8	20"
10	24"
12	24"
20	36"
22	36"
24	36"

Plot Date: 7/13/2009 12:04:46 PM Plot By: Chuck Haas File Name: D:\00000000000000000000\lanefrantz\Std-D003.dwg

REVISIONS						
NO.	DESCRIPTION	BY	DATE	CHK	DATE	APR
A	-	-	-	-	-	-

TYPICAL CONSTRUCTION DETAIL		
BLACKTOP ROAD CONSTRUCTION STANDARD SINGLE DITCH DIMENSION FOR CARRIER PIPE WITH FIBER OPTIC CONDUIT/S		
SCALE: NONE	DWG. NUMBER: <b>STD-D003</b>	REV: <b>A</b>

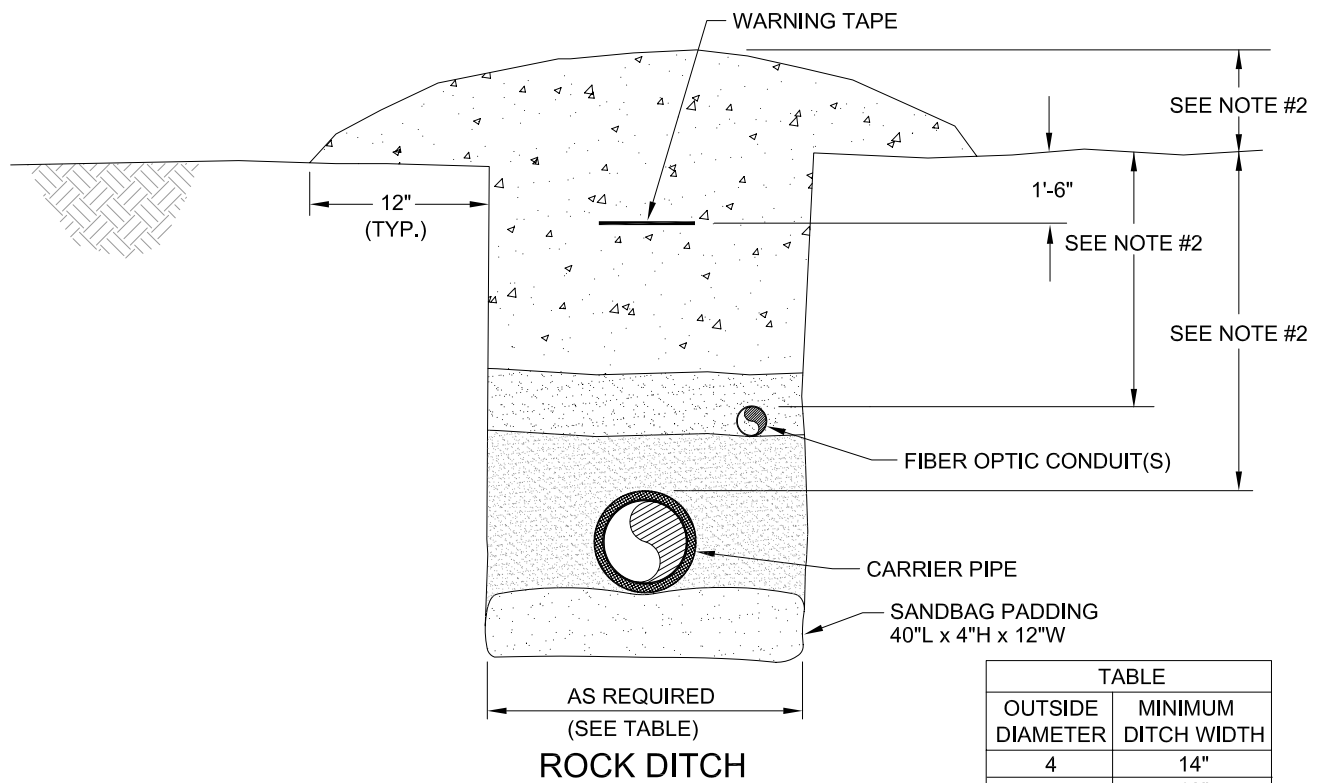
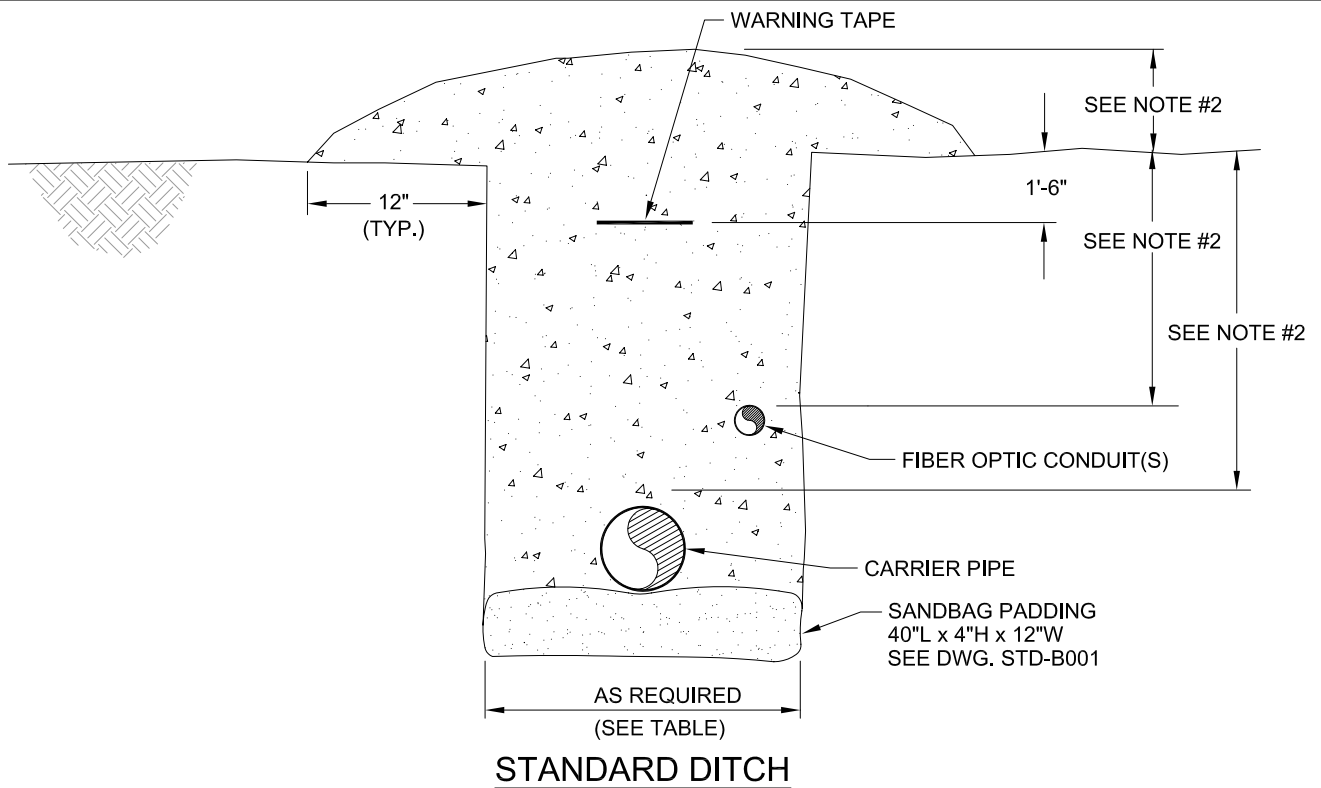

TABLE	
OUTSIDE DIAMETER	MINIMUM DITCH WIDTH
4	14"
6	18"
8	20"
10	24"
12	24"
20	36"
22	36"
24	36"

**NOTES:**

1. SEE CONSTRUCTION DOCUMENTS FOR PADDING REQUIREMENTS UNDER PIPE.
2. SEE CONSTRUCTION DOCUMENTS AND DRAWINGS FOR ALL BACKFILL DIMENSIONS.
3. BERMS SHALL NOT BE INSTALLED IN THE RAILROAD R/W.

REVISIONS							
NO.	DESCRIPTION	BY	DATE	CHK	DATE	APR	DATE
A	-	-	-	-	-	-	-

<b>TYPICAL CONSTRUCTION DETAIL</b>		
CROSS-COUNTRY AND R.R. R-O-W CONSTRUCTION STANDARD SINGLE DITCH DIMENSION FOR CARRIER PIPE WITH FIBER OPTIC CONDUIT(S) (ALT)		
SCALE: NONE	DWG. NUMBER: <b>STD-D004</b>	REV: <b>A</b>

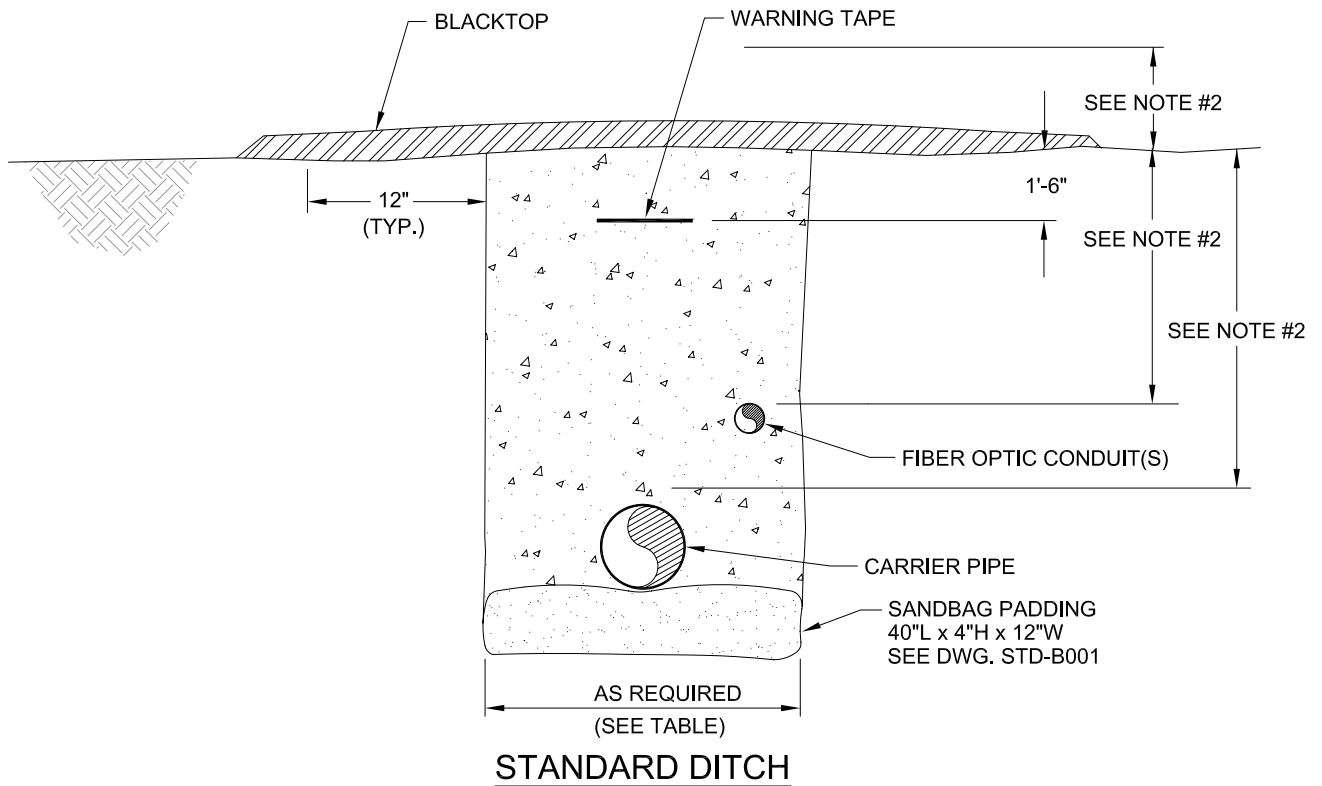

**STANDARD DITCH**

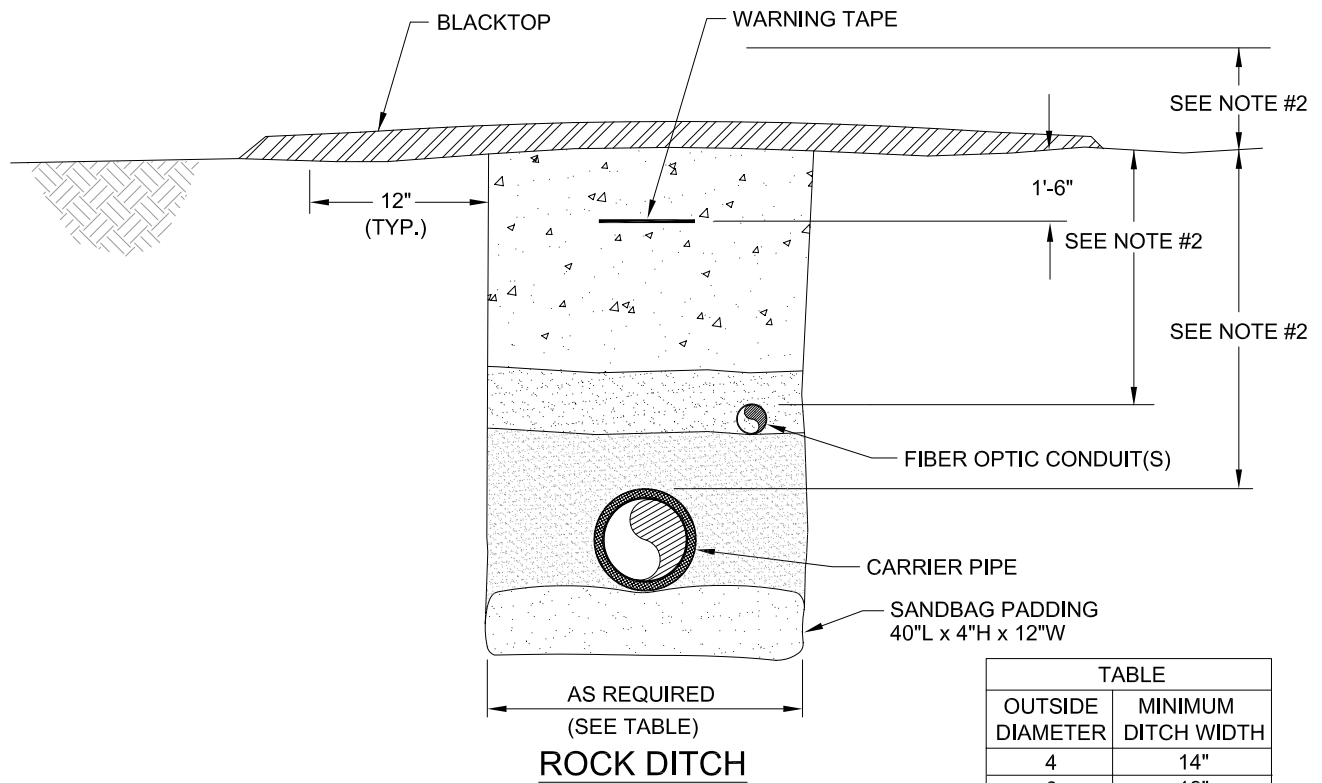

**ROCK DITCH**

TABLE	
OUTSIDE DIAMETER	MINIMUM DITCH WIDTH
4	14"
6	18"
8	20"
10	24"
12	24"
20	36"
22	36"
24	36"

**NOTES:**

1. SEE CONSTRUCTION DOCUMENTS FOR PADDING REQUIREMENTS UNDER PIPE.
2. SEE CONSTRUCTION DOCUMENTS AND DRAWINGS FOR ALL BACKFILL DIMENSIONS.
3. BERMS SHALL NOT BE INSTALLED IN THE RAILROAD R/W.
4. DEPTH IS 1'-0" GREATER IN RAILROAD R/W.

REVISIONS							
NO.	DESCRIPTION	BY	DATE	CHK	DATE	APR	DATE
A	-	-	-	-	-	-	-

<b>TYPICAL CONSTRUCTION DETAIL</b>		
ASPHALT ROAD CONSTRUCTION STANDARD SINGLE DITCH DIMENSION FOR CARRIER PIPE WITH FIBER OPTIC CONDUIT(S) (ALT)		
SCALE: NONE	DWG. NUMBER: <b>STD-D005</b>	REV: <b>A</b>

# DITCH SPECIFICATION

## DITCH DIMENSIONS

THE MINIMUM DIMENSIONS OF THE FINISHED DITCH SHALL CONFORM TO THE TABLE SHOWN. THE DEPTH OF THE DITCH SHALL BE MEASURED FROM THE LEVEL OF THE GRADED GROUND ON EACH SIDE OF THE DITCH.

WHEN PIPELINE IS WITHIN 50 FEET OF ANY PRIVATE DWELLING OR BUILDING WHERE PERSONS WORK OR CONGREGATE, AN ADDITIONAL 12 INCHES OF SHALL BE PROVIDED.

## NORMAL EXCAVATION

SIZE OF LINE	COVER A	WIDTH B	STANDARD DEPTH N
3	36"	12"	46"
4	36"	14"	47"
6	36"	18"	49"
8	36"	20"	51"
10	36"	24"	53"
12	36"	28"	55"
14	36"	30"	56"
16	36"	32"	58"
18	36"	36"	60"
20	36"	38"	62"
22	36"	40"	64"
24	36"	42"	66"
26	36"	42"	68"
28	36"	42"	70"
30	36"	46"	72"
32	36"	46"	74"
34	36"	48"	76"
36	36"	48"	78"

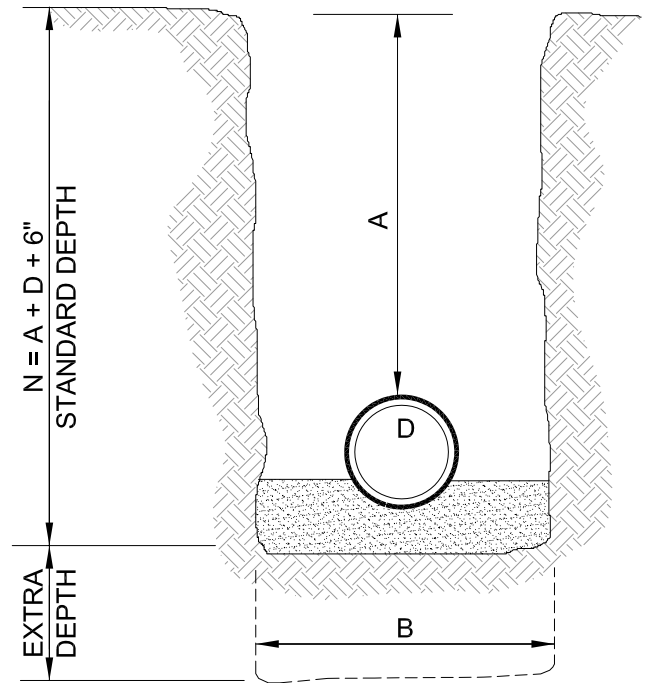

### NOTE:

SIX (6) INCH PADS OF LOOSE SOFT EARTH, TAMPED DOWN, OR BAGS OF SAND ARE TO BE PLACED IN DITCH TO SUSPEND PIPE A MINIMUM OF FOUR (4) INCHES ABOVE DITCH BOTTOM IN AREAS WHERE ROCK OR CLODS COULD DAMAGE COATING.

Plot Date: 7/13/2009 12:08:26 PM Plot By: Chuck Haas File Name: D:\00000000000000000000\lanefrantz\Std-D006.dwg

REVISIONS								TYPICAL CONSTRUCTION DETAIL		
NO.	DESCRIPTION	BY	DATE	CHK	DATE	APR	DATE	DITCH SPECIFICATION		
								SCALE: NONE	DWG. NUMBER: <b>STD-D006</b>	REV: <b>A</b>

## ROCK EXCAVATION

SIZE OF LINE	COVER* "A"	DITCH WIDTH
3	18"	16"
4	18"	18"
6	18"	22"
8	18"	24"
10	18"	28"
12	18"	32"
14	18"	34"
16	18"	36"
18	18"	40"
20	18"	44"
22	18"	48"
24	18"	52"
26	18"	52"
28	18"	52"
30	18"	58"
32	18"	58"
34	18"	60"
36	18"	60"

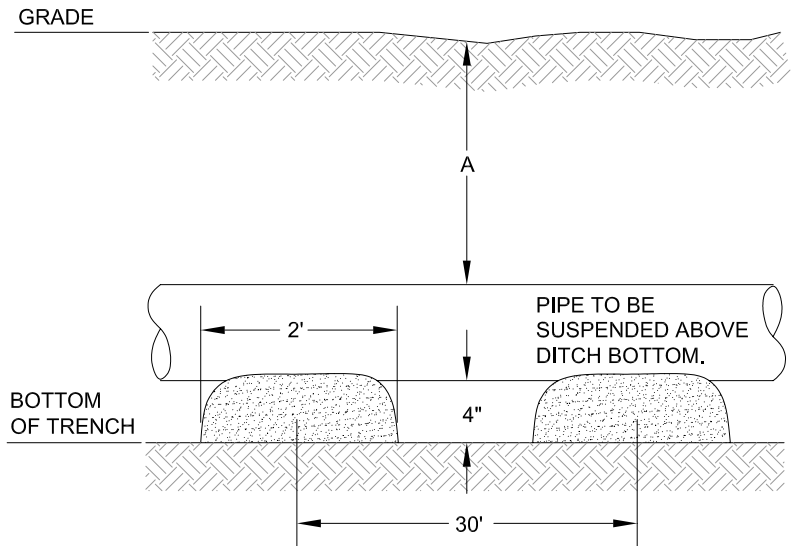

**NOTE:** SIX (6) INCH PADS OF LOOSE, SOFT EARTH, TAMPED DOWN, OR BAGS OF SAND ARE TO BE PLACED IN DITCH TO SUSPEND PIPE A MINIMUM OF FOUR (4) INCHES ABOVE DITCH BOTTOM IN AREAS WHERE ROCK OF CLDS COULD DAMAGE THE COATING.

\* COVER TO BE A MINIMUM OF 30" IN INDUSTRIAL, COMMERCIAL AND RESIDENTIAL AREAS AND 36" IN DRAINAGE DITCHES AT PUBLIC ROADS AND RAILROADS.

REVISIONS							
NO.	DESCRIPTION	BY	DATE	CHK	DATE	APR	DATE
A	-	-	-	-	-	-	-

<b>TYPICAL CONSTRUCTION DETAIL</b>		
<b>ROCK EXCAVATION</b>		
SCALE: NONE	DWG. NUMBER: <b>STD-D007</b>	REV: <b>A</b>

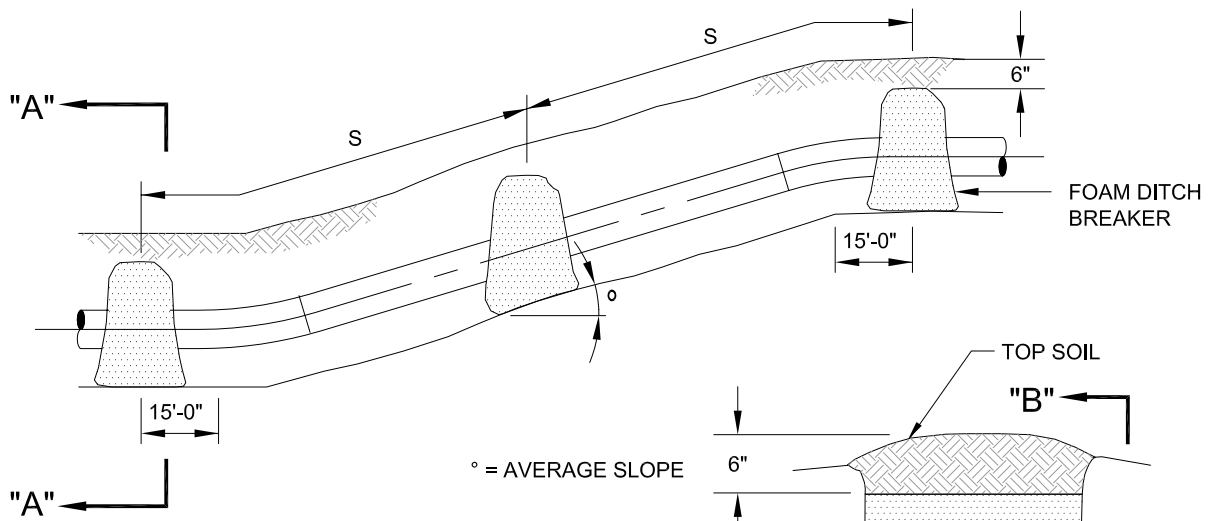

° = AVERAGE SLOPE

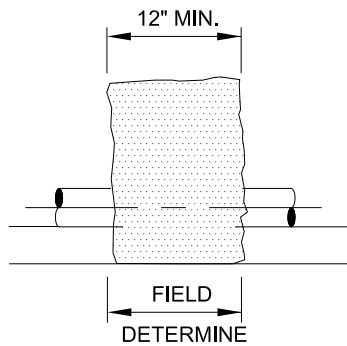
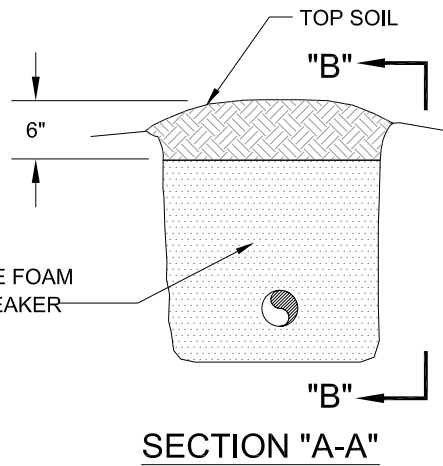

**SECTION "B-B"**

AVG. SLOPE (°)	SPACING (S)
<3°	NONE
3° - 9°	300'
9° - 17°	150'
17° - 24°	75'
>24°	25' - 50'

**NOTES:**

- BREAKERS SHALL BE INSTALLED AT SHARP CHANGES OF SLOPE ( $\pm 5^\circ$ ) ALONG TRENCHLINE AND AT LOCATIONS WHERE THE NATURAL DRAINAGE PATTERNS, PROFILE OR BACKFILL MATERIAL WILL CAUSE THE TRENCH TO ACT AS A DRAIN.
- BREAKER SPACING TO BE MEASURED ALONG TRENCH BOTTOM AND RECALCULATED FOR DISTINCT CHANGES IN AVERAGE SLOPE ( $\pm 5^\circ$ ).
- SAND BAGS MAY BE USED INSTEAD OF URETHANE FOAM. PAYMENT SHALL BE PER DITCH BREAKER OR PLUG AND NOT PER SACK.

REVISIONS							
NO.	DESCRIPTION	BY	DATE	CHK	DATE	APR	DATE
A	-	-	-	-	-	-	-

TYPICAL CONSTRUCTION DETAIL		
DITCH BREAKERS OR PLUG REQUIREMENTS		
SCALE: NONE	DWG. NUMBER: <b>STD-D008</b>	REV: <b>A</b>

Plot Date: 7/13/2009 12:10:12 PM Plot By: Chuck Haas File Name: D:\00000000000000000000\lanefrantz\Std-D008.dwg

## CHAIN LINK FENCE

1. FABRIC SHALL BE ALUMINUM COATED 9 GAUGE 2-INCH MESH CHAIN-LINK FENCING 6FT. HIGH WITH TWISTING AND BARBS ON BOTH SELVAGES. TENSILE STRENGTH OF FABRIC SHALL BE 80,000 PSI.
2. BARBED WIRE SHALL CONSIST OF THREE 12-1/2 GAUGE STRANDED LINE WIRES WITH AN ALUMINUM COATING OF AT LEAST 0.30 OUNCES PER SQUARE FOOT OF WIRE SURFACE AND 14 GAUGE ALUMINUM BARBS IN A 4-FOOT PATTERN ON 5-INCH CENTERS.
3. BOTTOM TENSION WIRE SHALL BE A MINIMUM OF 7 GAUGE STEEL WITH AN ALUMINUM COATING OF AT LEAST 0.40 OUNCES PER SQUARE FOOT OF WIRE SURFACE. TENSION WIRE IS TO BE ATTACHED TO THE FABRIC USING 11 GAUGE ALUMINUM TIE RINGS AT 2 FT. INTERVALS.
4. TOP RAIL SHALL PASS THROUGH INTERMEDIATE POST TOPS AND FORM A CONTINUOUS BRACE WITHIN EACH STRETCH OF FENCE AND BE SECURELY FASTENED TO TERMINAL POSTS.
5. POST BRACES SHALL BE PROVIDED FOR EACH GATE, CORNER, PULL AND TERMINAL POSTS. BRACE SHALL BE OF THE SAME MATERIAL AS TOP RAIL AND TRUSSED TO LINE POSTS WITH 3/8" DIAMETER RODS AND ADJUSTABLE TIGHTENERS.
6. FABRIC SHALL BE CONNECTED TO LINE POSTS WITH 6 GAUGE WIRE CLIPS EVERY 14"; TO TOP RAIL WITH 9 GAUGE WIRE EVERY 24"; TO TERMINAL, CORNER AND GATE POSTS BY INTEGRALLY WEAVING INTO THE POST OR BY USING 1/4" X 3/4" TENSION BARS TIED TO THE POST EVERY 14" WITH 11 GAUGE 1" WIDE STEEL BANDS AND 3/8" DIAMETER BOLTS AND NUTS TO TENSION WIRE WITH 11 GAUGE TIE-RINGS EVERY 24".
7. POST TOPS SHALL FIT OVER THE OUTSIDE OF POSTS AND EXCLUDE MOISTURE FROM TUBULAR POSTS. LINE POST TOPS SHALL BE COMBINATION TOPS AND BARBED WIRE SUPPORTING ARMS. THE BARBED WIRE ARM SHALL BE OF SUFFICIENT STRENGTH TO WITHSTAND A WEIGHT OF 450 POUNDS APPLIED AT THE OUTER STRAND OF BARBED WIRE. ORNAMENTAL TOPS SHALL BE USED ON TERMINAL CORNER AND GATE POSTS.
8. GATE FRAMES SHALL BE 1.90" O.D. PIPE CONNECTED WITH FITTINGS AND RIVETED AT EACH CORNER. EACH FRAME SHALL HAVE 3/8" DIAMETER ADJUSTABLE TRUSS RODS. GATES SHALL HAVE POSITIVE TYPE LATCHING DEVICES WITH PROVISIONS FOR PADLOCKING, AND DRIVE GATES SHALL HAVE A CENTER PLUNGER ROD, CATCH AND SEMI-AUTOMATIC OUTER CATCHES.
9. POSTS, GATE FRAMES, BRACES, RAILS, STRETCHER BARS AND TRUSS RODS SHALL BE OF STEEL. REINFORCING WIRES SHALL BE OF HIGH CARBON STEEL. GATE HINGES, POST CAPS, BARBED WIRE SUPPORTING ARMS, STRETCHER BAR BANDS AND OTHER PARTS SHALL BE OF STEEL, MALLEABLE IRON, DUCTILE IRON, OR EQUAL, EXCEPT THAT TIES AND CLIPS MAY BE OF ALUMINUM. ALL STEEL AND IRON SHALL BE ZINC COATED AFTER FABRICATION WITH A ZINC COATING OF 2.0 OUNCES PER SQUARE FOOT OF SURFACE AREA.
10. DIMENSIONS:

DESCRIPTION	RECTANGULAR MEMBER		TUBULAR MEMBER	
	DIMENSION IN INCHES	WEIGHT LBS/FT.	O.D. INCHES	WEIGHT LBS/FT.
TERMINAL POSTS	3-1/2 x 3-1/2	5.14	2-7/8	5.79
LINE POSTS	1-7/8 x 1-5/8	2.72	2-3/8	3.65
TOP AND BRACE RAILS	1-5/8 x 1-1/4	1.35	1.66	1.82
GATE POSTS (SLIDING GATES)	-	-	4	9.11
GATE POSTS (SWING GATES)				
GATES WIDTH UNDER 6'	3-1/2 x 3-1/2	5.14	2-7/8	5.79
GATE WIDTH 6' TO 13'			4	9.11
GATE WIDTH 13' TO 18'			6-5/8	18.97
GATE WIDTH OVER 18'			8-5/8	24.70

11. LINE POSTS SHALL BE EVENLY SPACED 10 FT. OR LESS APART.

REVISIONS								TYPICAL CONSTRUCTION DETAIL		
NO.	DESCRIPTION	BY	DATE	CHK	DATE	APR	DATE			
A	-	-	-	-	-	-	-	CHAIN LINK FENCE MATERIAL SPECIFICATION		

Plot Date: 7/13/2009 12:42:21 PM Plot By: Chuck Haas File Name: D:\000000000000\lane\frantz\Std-F002.dwg

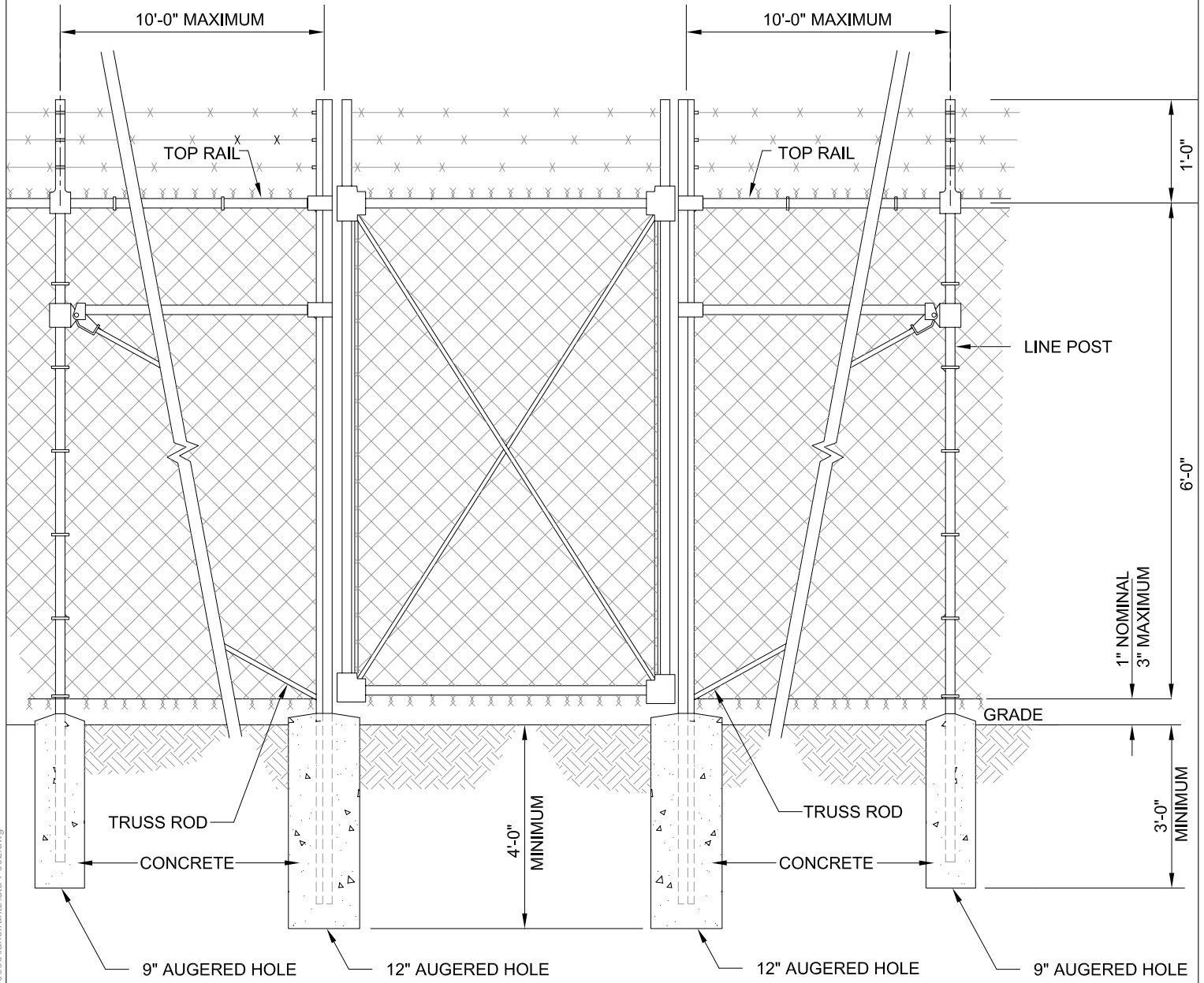

**NOTES:**

1. CONCRETE TO BE POURED TO GRADE AND ROUNDED ON TOP.
2. ALL MATERIAL TO BE FURNISHED BY CONTRACTOR.
3. SEE DWG. STD-F001 FOR MATERIAL SPECIFICATIONS.

REVISIONS						
NO.	DESCRIPTION	BY	DATE	CHK	DATE	APR
A	-	-	-	-	-	-

<b>TYPICAL CONSTRUCTION DETAIL</b>		
PIPELINE SPECIFICATION CHAIN LINK FENCE SWING GATE		
SCALE: NONE	DWG. NUMBER: <b>STD-F002</b>	REV: <b>A</b>

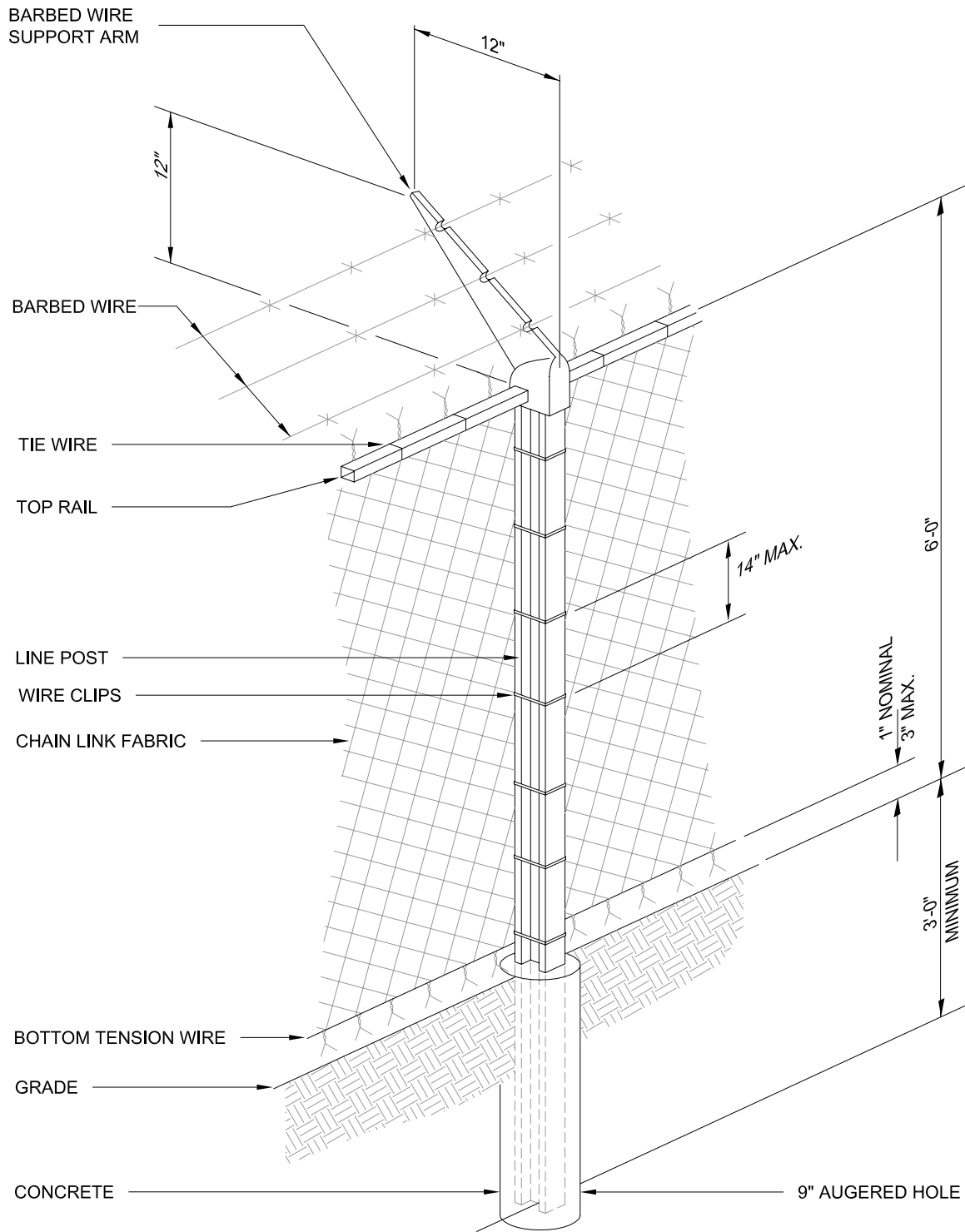

**NOTES**

1. CONCRETE TO BE POURED TO GRADE AND ROUNDED ON TOP.
2. ALL MATERIAL TO BE FURNISHED BY CONTRACTOR.
3. SEE DWG. STD-F001 FOR MATERIAL SPECIFICATIONS.
4. MAXIMUM DISTANCE BETWEEN LINE POLES SHALL BE 10'-0".

REVISIONS

NO.	DESCRIPTION	BY	DATE	CHK	DATE	APR	DATE
A	-	-	-	-	-	-	-

TYPICAL CONSTRUCTION DETAIL

PIPELINE SPECIFICATION  
CHAIN LINK FENCE  
INTERMEDIATE LINK POST

SCALE: NONE

DWG. NUMBER: **STD-F003**

REV: A

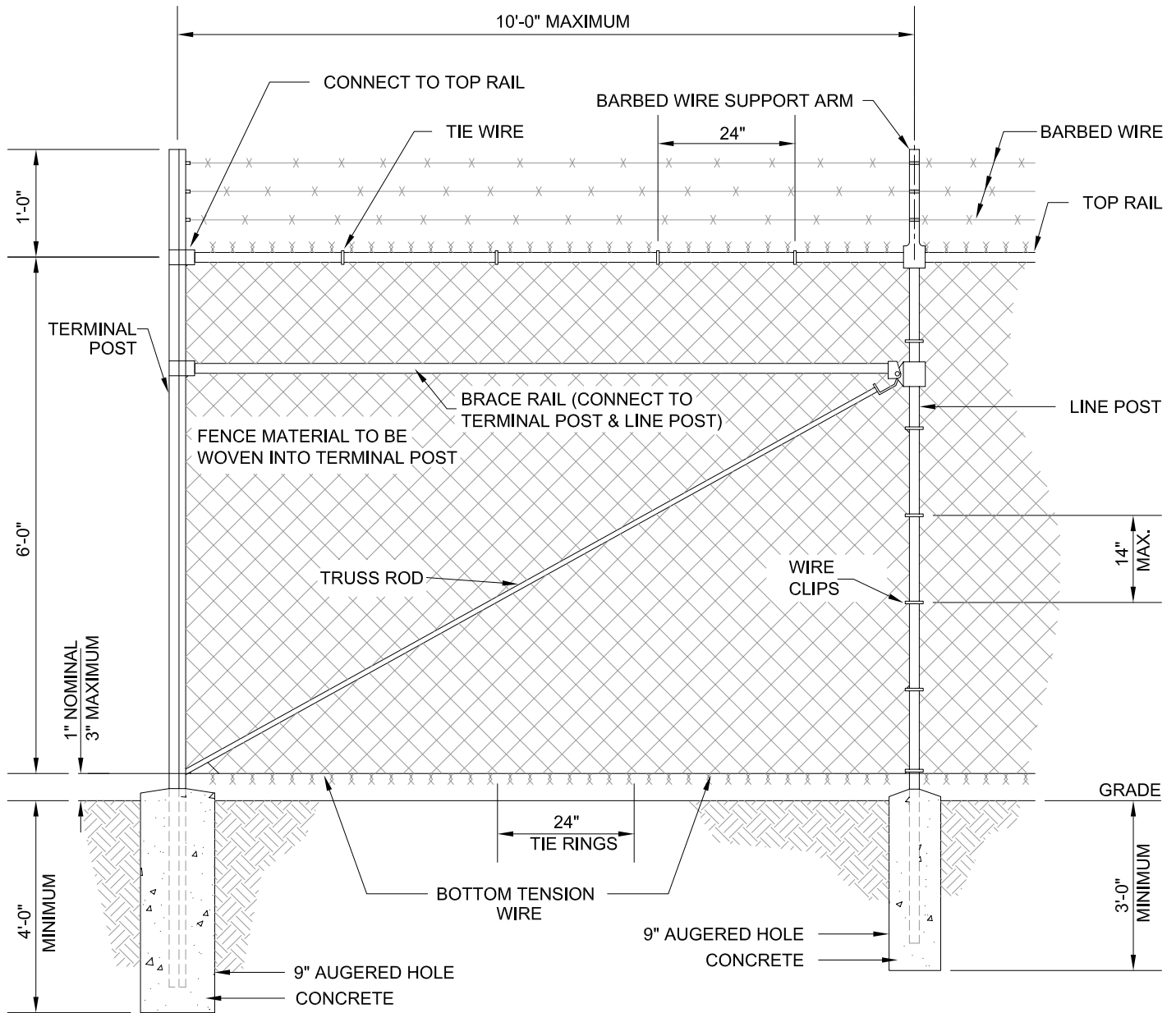

**NOTES:**

1. CONCRETE TO BE POURED TO A GRADE AND ROUNDED ON TOP.
2. ALL MATERIAL TO BE FURNISHED BY CONTRACTOR.
3. SEE DWG. STD-F001 FOR MATERIAL SPECIFICATIONS.

REVISIONS						
NO.	DESCRIPTION	BY	DATE	CHK	DATE	APR
A	-	-	-	-	-	-

<b>TYPICAL CONSTRUCTION DETAIL</b>		
PIPELINE SPECIFICATION CHAIN LINK FENCE TERMINAL POST		
SCALE: NONE	DWG. NUMBER: <b>STD-F004</b>	REV: <b>A</b>

BRACE SPAN  
EACH SIDE OF  
PIPELINE  
SEE DETAIL

LINE MARKER SHALL BE  
PLACED IN FENCE  
DIRECTLY OVER PIPELINE  
IN FENCES NOT  
OTHERWISE MARKED.

BRACE SPAN  
EACH SIDE OF  
PIPELINE  
SEE DETAIL

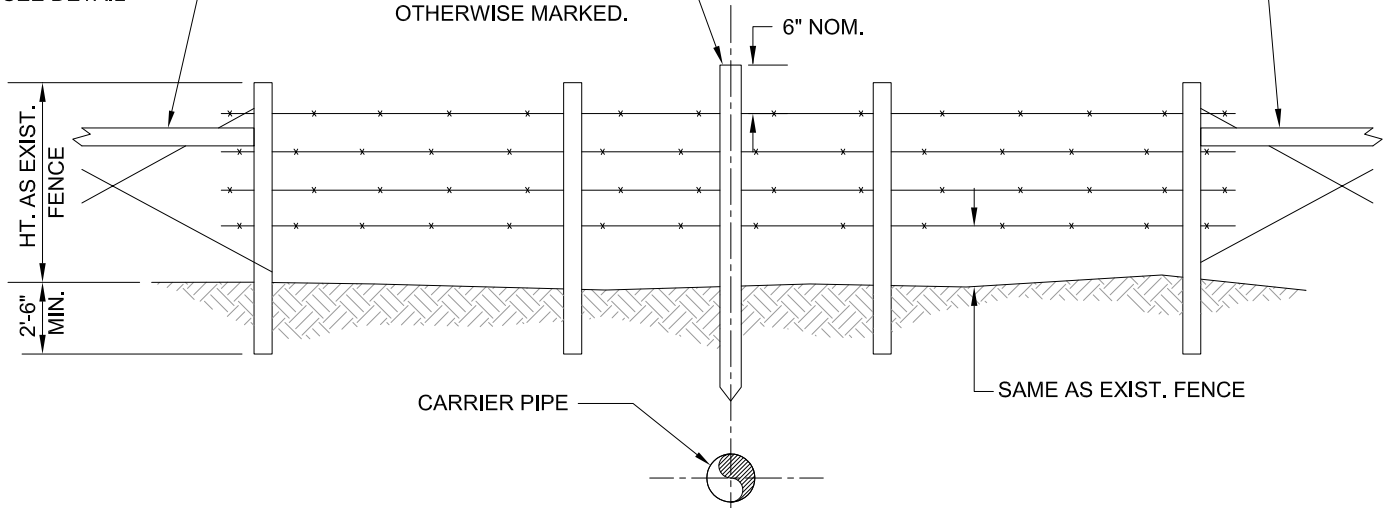

**ELEVATION**

NEW CORNER POSTS  
(4" DIA. TREATED WOOD  
OR EQUAL TO EXIST.  
FENCE MATERIAL)

2 STRANDS OF  
#9 GALVANIZED  
TWISTED WIRE

4" DIA.  
WOOD BRACE

2 STRANDS OF  
#9 GALVANIZED  
TWISTED WIRE

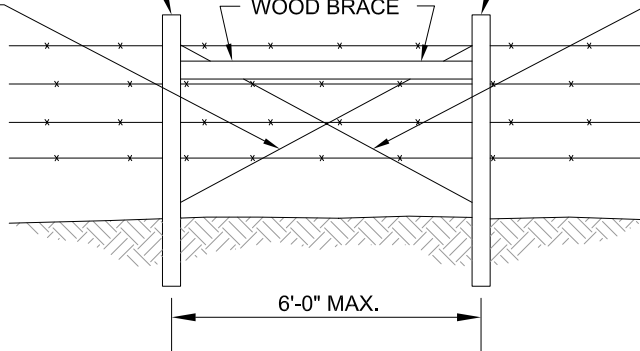

**BRACE SPAN DETAIL**

SEE NOTE 2

1. POSTS, WIRE AND OTHER MATERIAL SHALL BE OF EQUAL OR NEW MATERIAL TO MATCH EXISTING FENCE.
2. BRACE SPAN SHALL BE CONSTRUCTED ON EACH SIDE OF PIPELINE CROSSING PRIOR TO INITIAL DISMANTLING OF FENCE.
3. MARKERS SHALL BE INSTALLED AT PROPERTY LINE FENCES ONLY.

REVISIONS

NO.	DESCRIPTION	BY	DATE	CHK	DATE	APR	DATE
-							
A							

TYPICAL CONSTRUCTION DETAIL

FENCE  
CUT AND RESTORATION

SCALE: NONE

DWG. NUMBER: **STD-F010**

REV: **A**

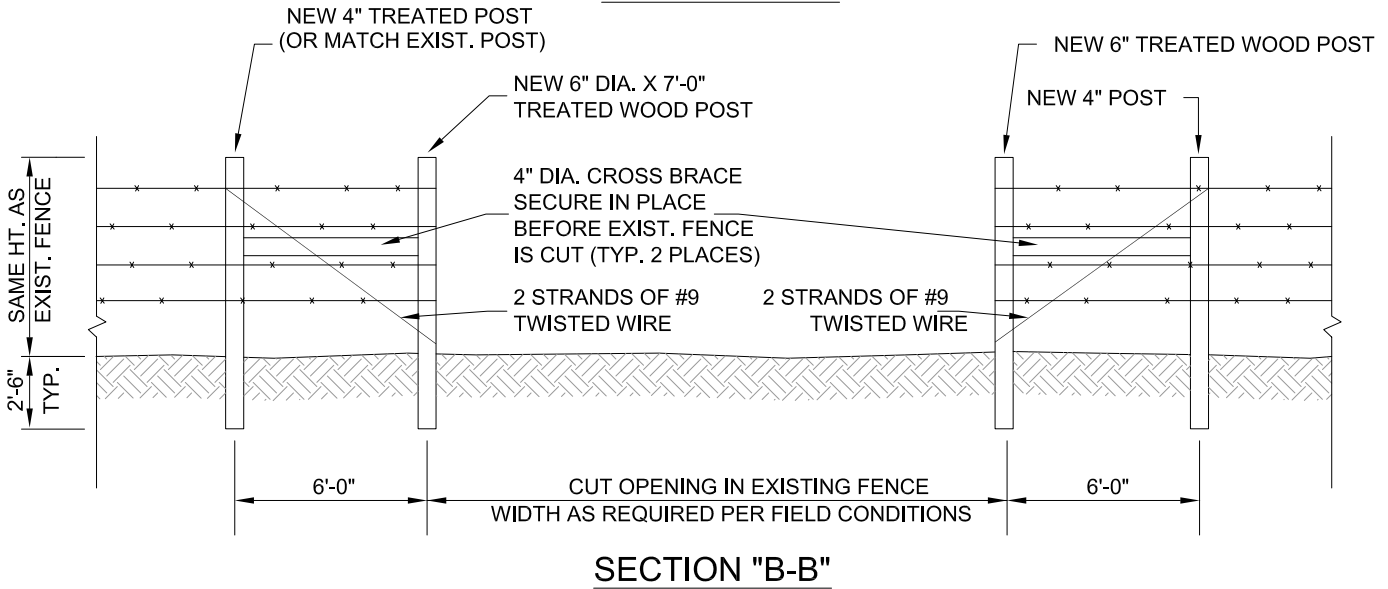
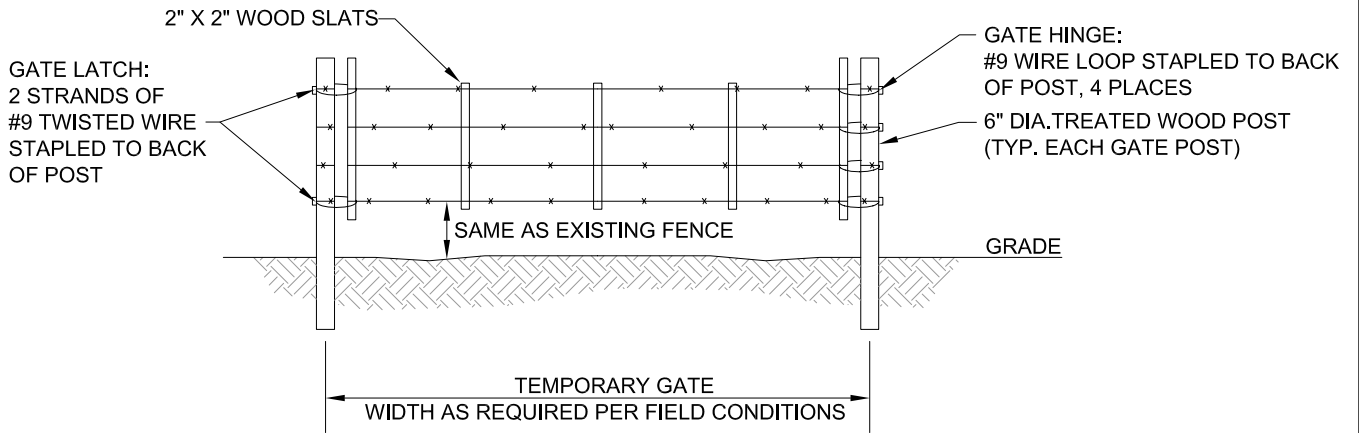
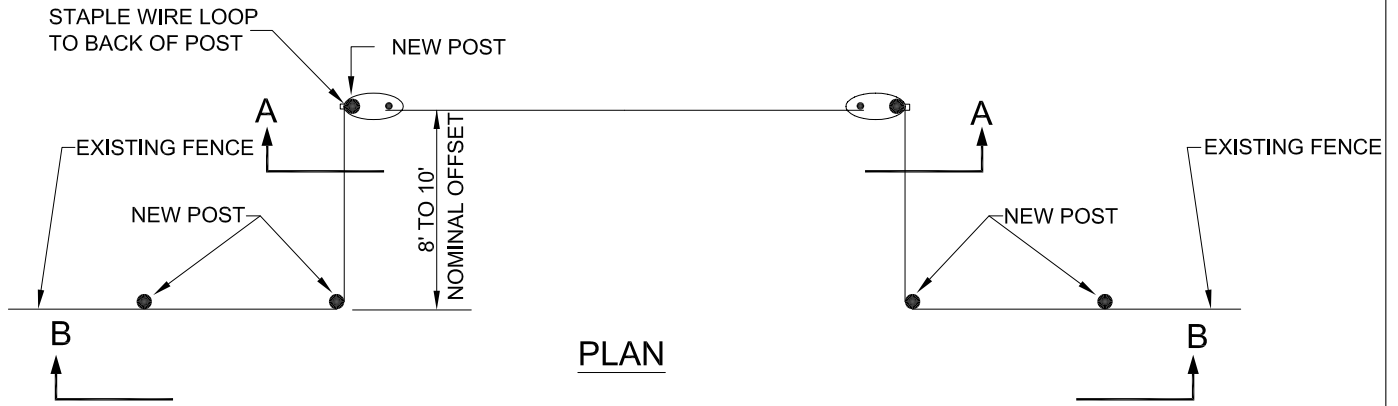

**NOTES:**

1. CONTRACTOR SHALL INSTALL AT ALL LOCATIONS DESIGNATED BY COMPANY.
2. OFFSET MAY BE INCREASED TO ALLOW ROAD CLEARANCE FOR LARGER VEHICLES WHILE OPENING OR CLOSING GATES.

REVISIONS						
NO.	DESCRIPTION	BY	DATE	CHK	DATE	APR

TYPICAL CONSTRUCTION DETAIL		
TEMPORARY FENCE GATES		
SCALE: NONE	DWG. NUMBER: <b>STD-F011</b>	REV: <b>A</b>

Plot Date: 7/13/2009 12:18:11 PM Plot By: Chuck Haas File Name: D:\0000000000000000\lanefranz\Std-F011.dwg

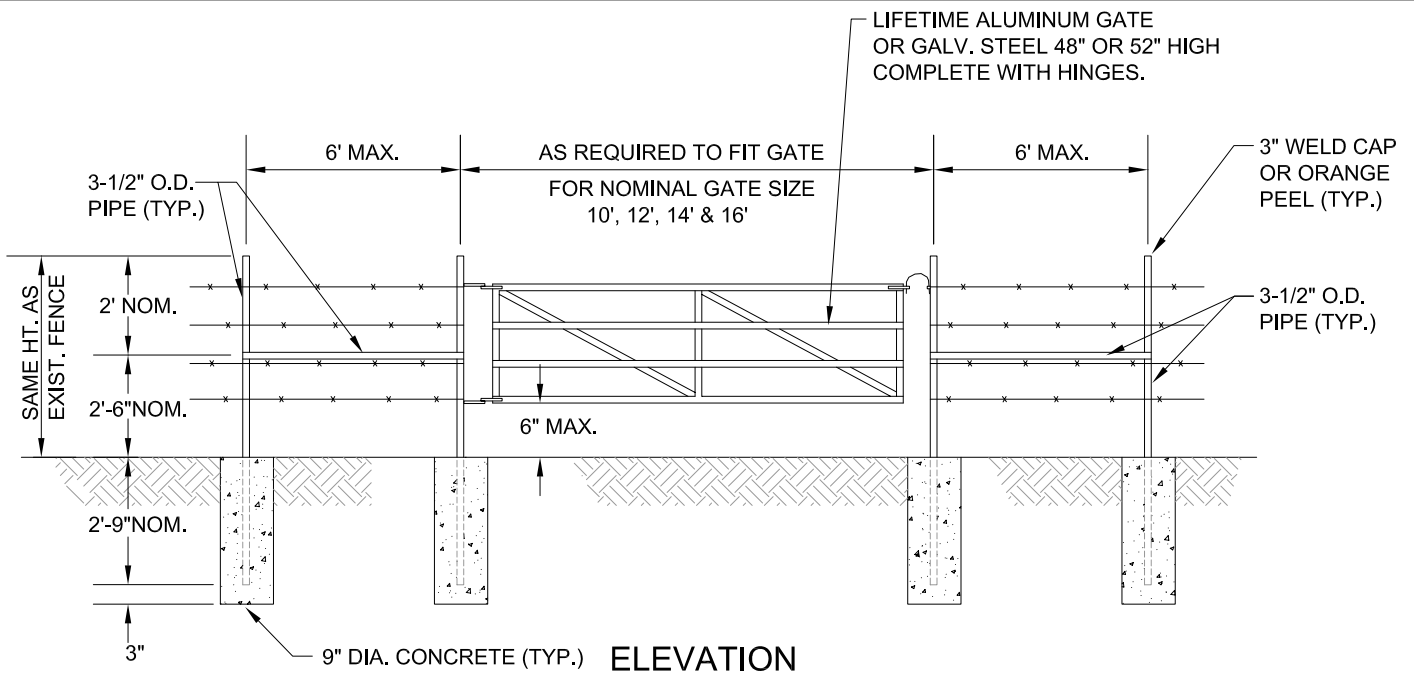

**ELEVATION**

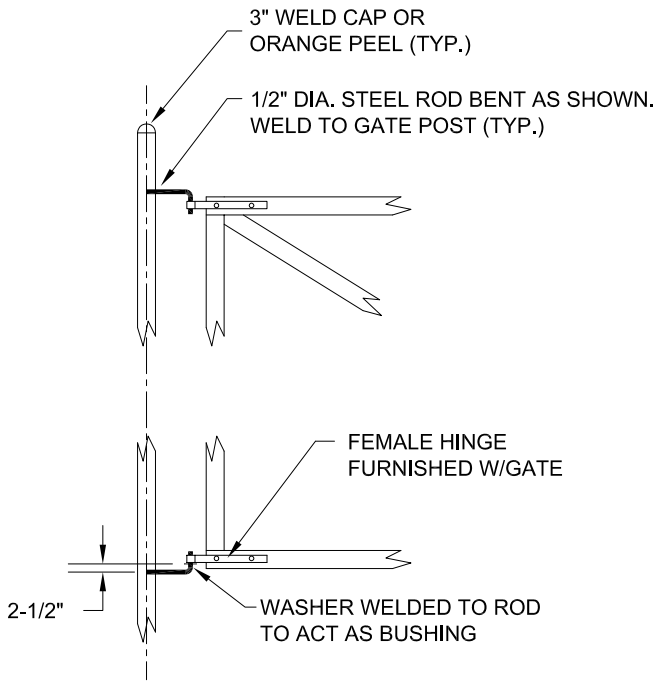

**ON-SITE FABRICATED HINGES**

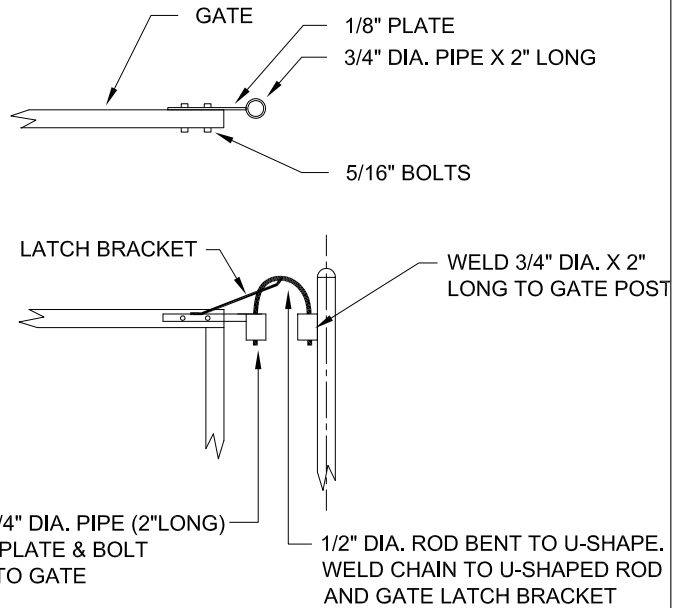

**SUGGESTED GATE LATCH**

**NOTES**

1. CONTRACTOR SHALL INSTALL AT LOCATIONS DESIGNATED BY COMPANY.
2. GATE CLEAR OPENING SHALL BE IN 2' INCREMENTS TO ACCOMODATE STANDARD ALLOWANCES FOR 4" HINGES & LATCHES ON COMMERCIAL GATES.
3. WHERE GATE IS INSTALLED PARALLEL TO, AND A DISTANCE EQUAL TO, OR LESS THAN GATE WIDTH FROM ROADWAY, CONTRACTOR SHALL EITHER:
  - A. PROVIDE LATCH OR STOP TO PREVENT GATE FROM SWINGING OUT OVER ROAD; OR
  - B. PROVIDE OFFSET IN FENCE TO PROVIDE ROAD CLEARANCE FOR VEHICLES STOPPING TO OPEN OR CLOSE GATE.

REVISIONS						
NO.	DESCRIPTION	BY	DATE	CHK	DATE	APR

TYPICAL CONSTRUCTION DETAIL		
PERMANENT RIGHT-OF-WAY FENCE GATES		
SCALE: NONE	DWG. NUMBER: <b>STD-F012</b>	REV: <b>A</b>

Plot Date: 7/13/2009 12:20:15 PM Plot By: Chuck Haas File Name: D:\0000000000000000\lanefrantz\Std-G001.dwg

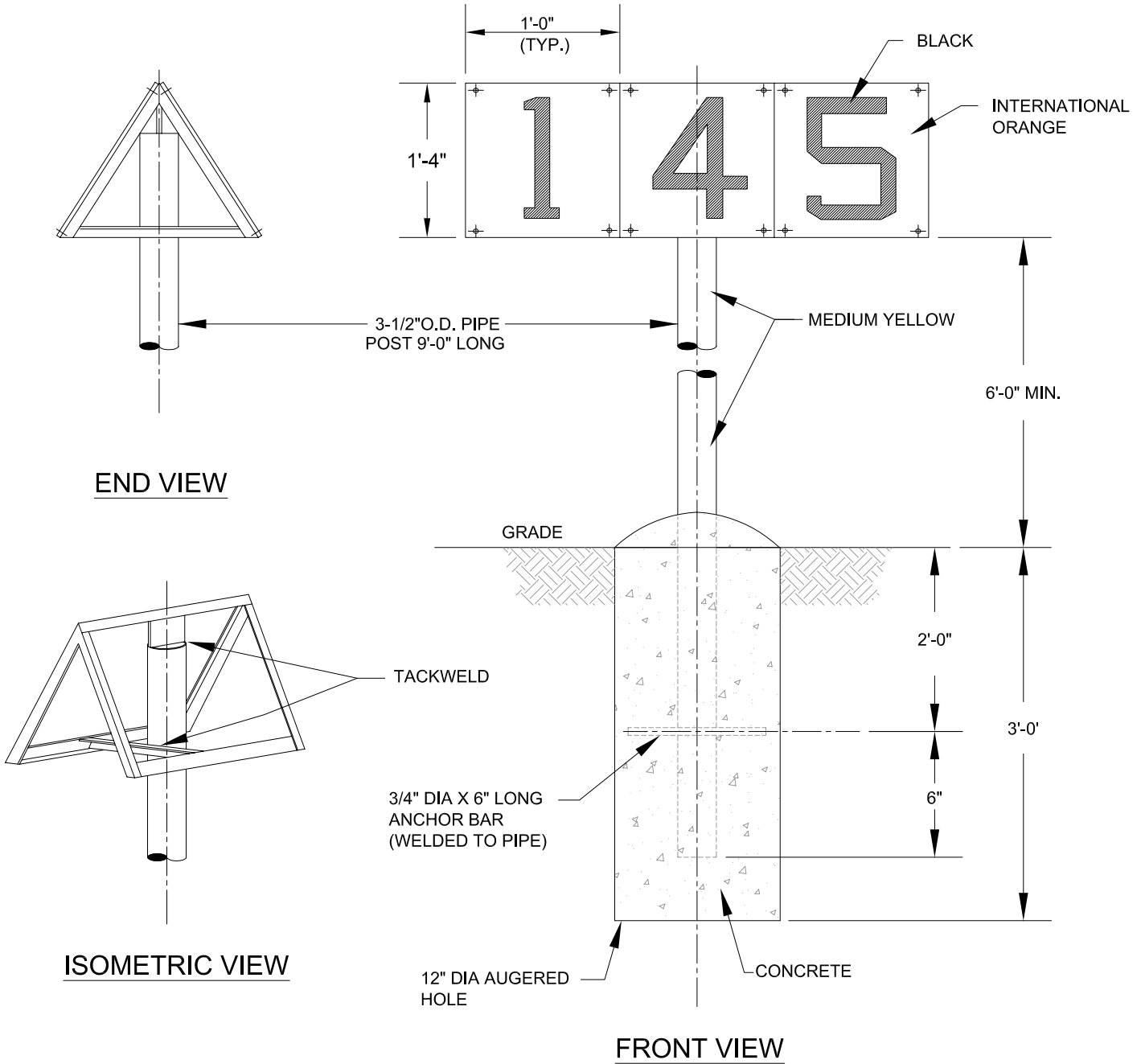

**NOTES:**

1. INSTALL 3-1/2" O.D. STD. WT. PIPE POST 10 FEET LONG OR AS REQUIRED BY LOCATION.
2. CONTRACTOR TO ASSEMBLE SIGN AND MOUNT ON POST.
3. SIGNAGE AND INTEGRAL FRAME FURNISHED BY COMPANY, PIPE, FASTENERS, ETC. FURNISHED BY CONTRACTOR.
4. CONCRETE TO BE POURED TO GRADE AND ROUNDED ON TOP.

REVISIONS							
NO.	DESCRIPTION	BY	DATE	CHK	DATE	APR	DATE
A	-	-	-	-	-	-	-

<b>TYPICAL CONSTRUCTION DETAIL</b>		
PIPELINE AERIAL MARKER		
SCALE: NONE	DWG. NUMBER: <b>STD-G001</b>	REV: <b>A</b>

# AERIAL MARKER

6 EACH 1" LONG TACK WELDS ON EACH SIDE  
WELD BOTH SIDES FULL 12" WIDTH

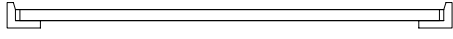

1"X 1" X 1/8" (HOT ROLLED STEEL) ANGLE IRON

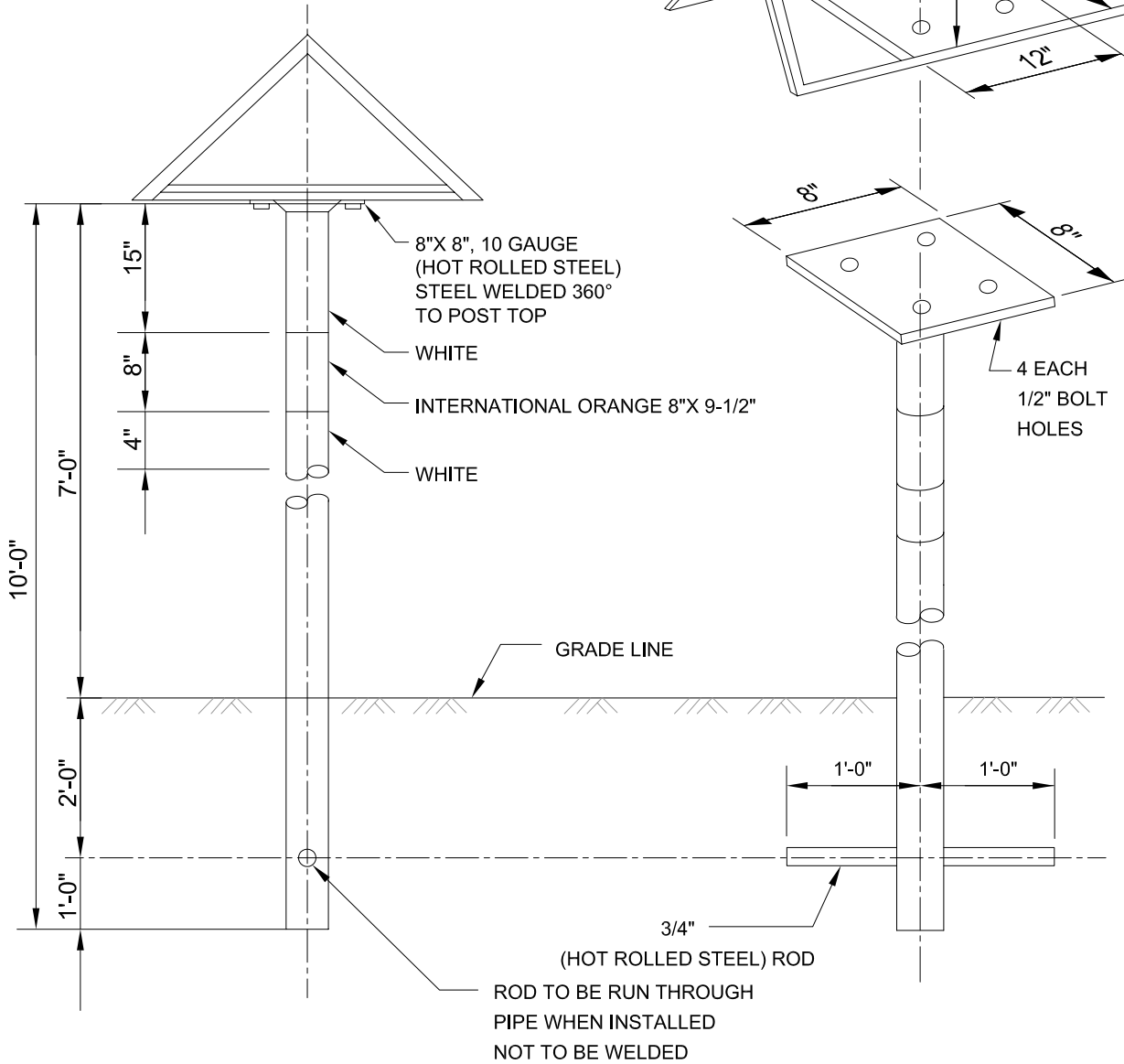
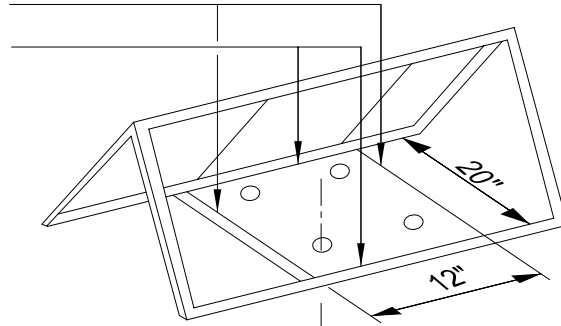

\* NOMINAL O.D. STRUCTURAL PIPE 10'-0" LONG

**COLORS:**

WHITE - BRACKET 8"X 8", 10 GAUGE (HOT ROLLED STEEL) AND PIPE POST.

INTERNATIONAL GAUGE - 8"X 9-1/2"

REVISIONS						
NO.	DESCRIPTION	BY	DATE	CHK	DATE	APR

TYPICAL CONSTRUCTION DETAIL		
AERIAL MARKER		
SCALE: NONE	DWG. NUMBER: <b>STD-G002</b>	REV: <b>A</b>

Plot Date: 7/13/2009 12:21:41 PM Plot By: Chuck Haas File Name: D:\00000000000000000000\lanefrantz\Std-G002.dwg



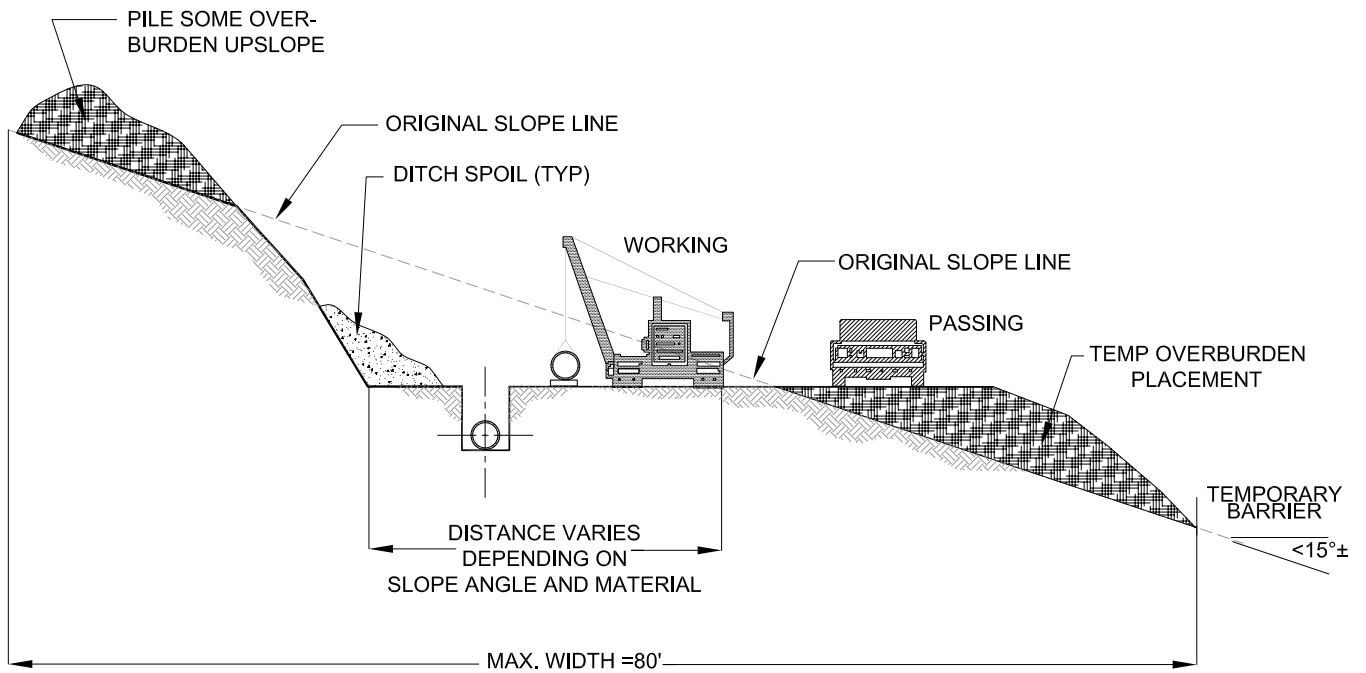

**SIDE SLOPES UP TO 15° NOMINAL**

OVERBURDEN IS SAVED AND USED TO RETURN SLOPE TO NEAR ORIGINAL CONTOUR

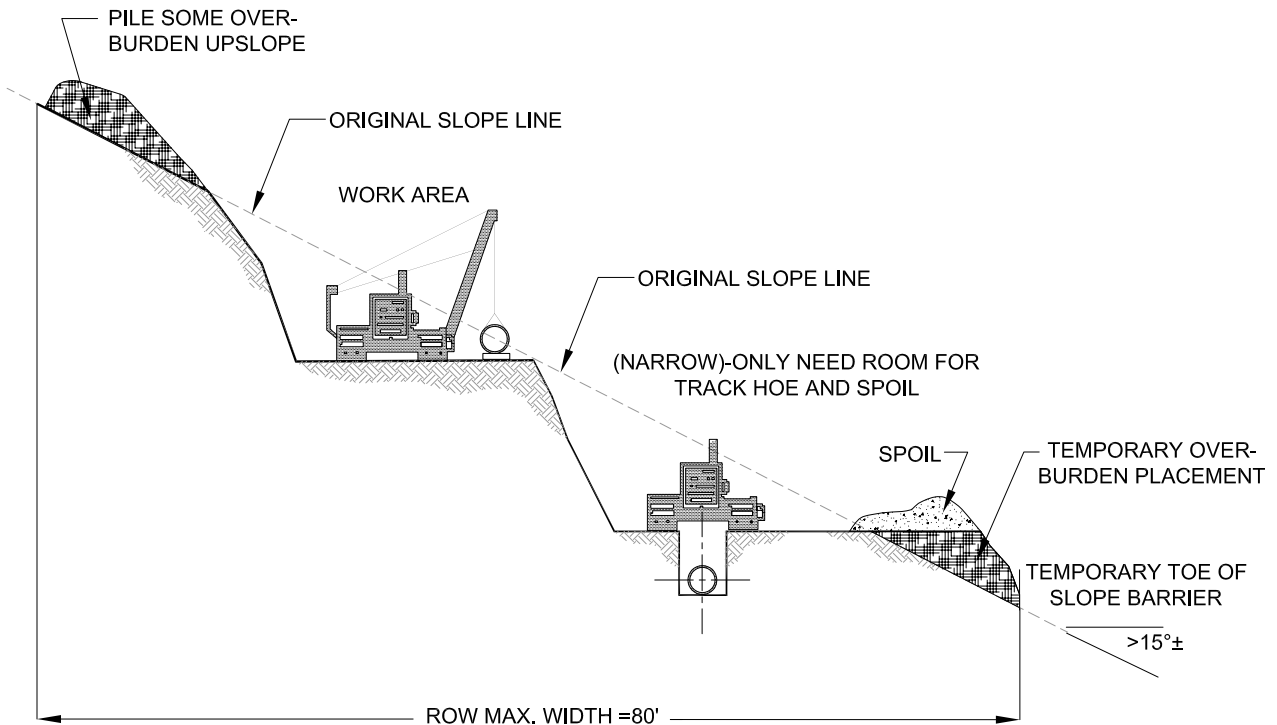

**SIDE SLOPES EXCEEDING 15° NOMINAL**

REVISIONS

NO.	DESCRIPTION	BY	DATE	CHK	DATE	APR	DATE
A	-	-	-	-	-	-	-

TYPICAL CONSTRUCTION DETAIL

TYPICAL SIDEHILL CONSTRUCTION TECHNIQUE

SCALE: NONE

DWG. NUMBER: **STD-G014**

REV: **A**

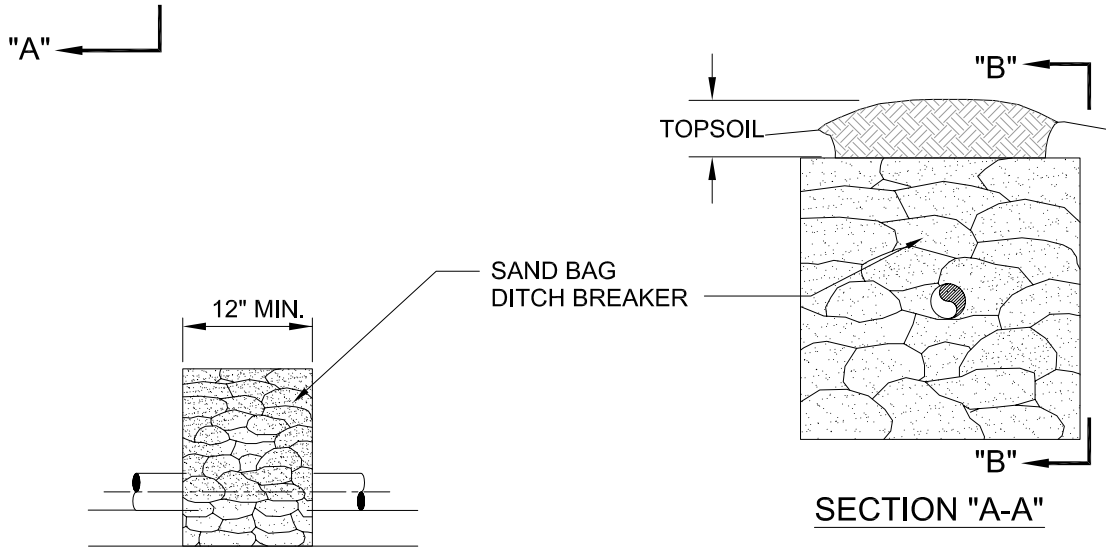
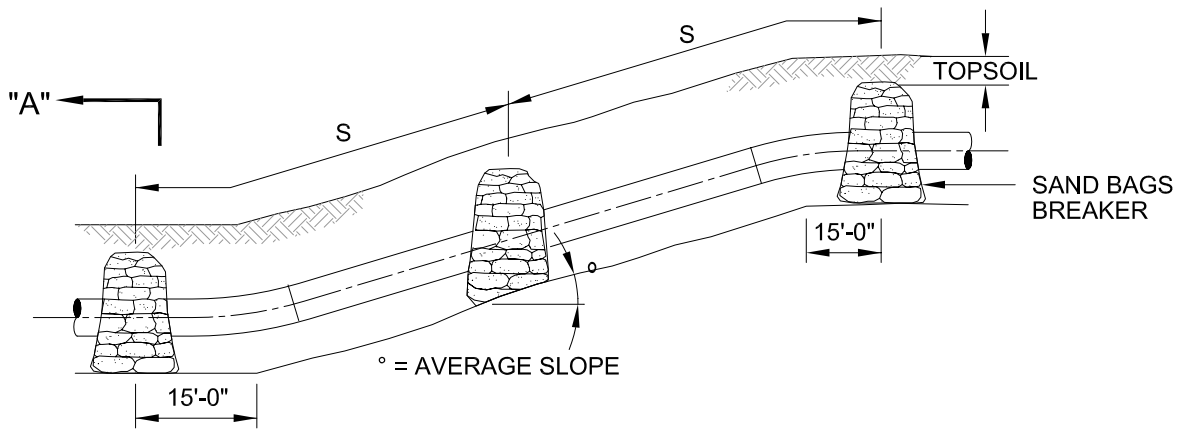

AVG. SLOPE (°)	SPACING (S)
<3°	NONE
3° - 9°	300'
9° - 17°	150'
17° - 24°	75'
>24°	25' - 50'

- NOTES:**
- BREAKERS SHALL BE INSTALLED AT SHARP CHANGES OF SLOPE ( $\pm 5^\circ$ ) ALONG TRENCHLINE AND AT LOCATIONS WHERE THE NATURAL DRAINAGE PATTERNS, PROFILE OR BACKFILL MATERIAL WILL CAUSE THE TRENCH TO ACT AS A DRAIN.
  - BREAKER SPACING TO BE MEASURED ALONG TRENCH BOTTOM AND RECALCULATED FOR DISTINCT CHANGES IN AVERAGE SLOPE ( $\pm 5^\circ$ ).
  - PAYMENT SHALL BE PER DITCH BREAKER OR PLUG AND NOT PER SACK.

REVISIONS							
NO.	DESCRIPTION	BY	DATE	CHK	DATE	APR	DATE
A	-	-	-	-	-	-	-

TYPICAL CONSTRUCTION DETAIL		
DITCH BREAKER OR PLUG REQUIREMENTS		
SCALE: NONE	DWG. NUMBER: <b>STD-R001</b>	REV: <b>A</b>

Plot Date: 7/13/2009 12:31:11 PM Plot By: Chuck Haas File Name: D:\00000000000000000000\lanefrantz\Std-R001.dwg

### ISOMETRIC SECTION

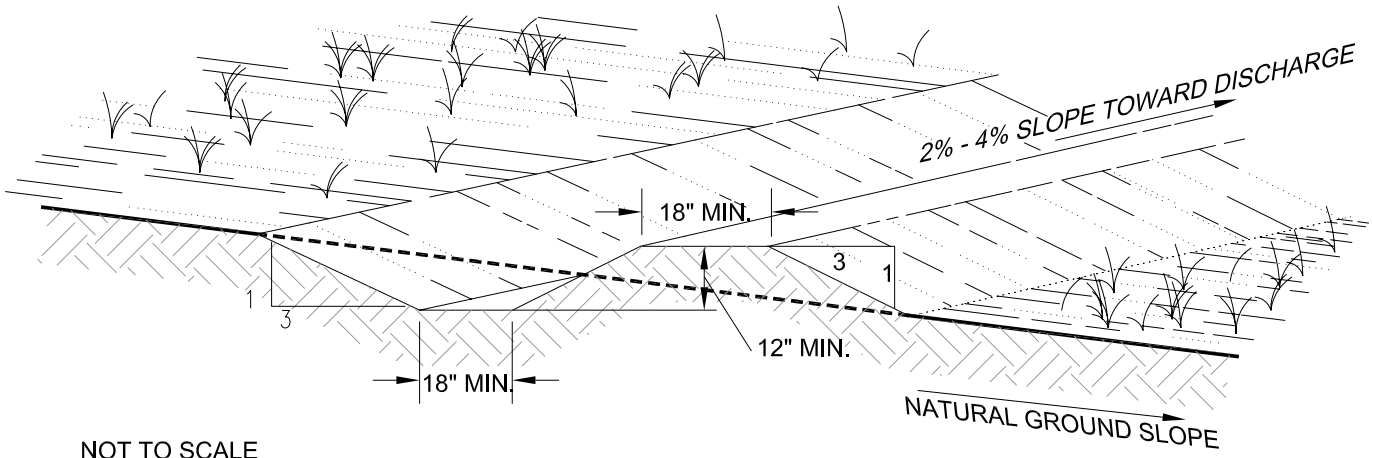

NOT TO SCALE

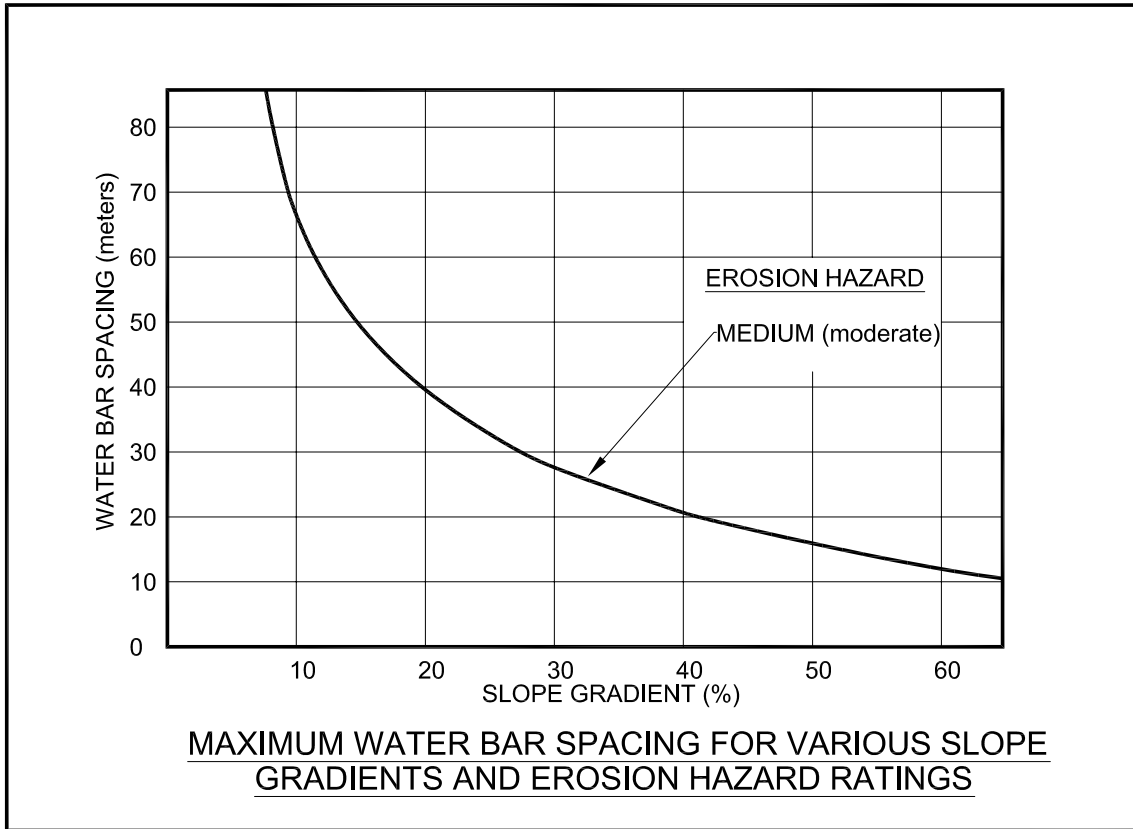

**MAXIMUM WATER BAR SPACING FOR VARIOUS SLOPE GRADIENTS AND EROSION HAZARD RATINGS**

Source: BLM 1989, EPA 1978a.

Plot Date: 7/13/2009 12:42:20 PM Plot By: Chuck Haas File Name: D:\0000000000000000\lanefrantz\Std-R002.dwg

REVISIONS						
NO.	DESCRIPTION	BY	DATE	CHK	DATE	APR

<b>TYPICAL CONSTRUCTION DETAIL</b>		
<b>TYPICAL WATER BAR DETAIL</b>		
SCALE: NONE	DWG. NUMBER: <b>STD-R002</b>	REV: <b>A</b>

## PERSPECTIVE VIEW

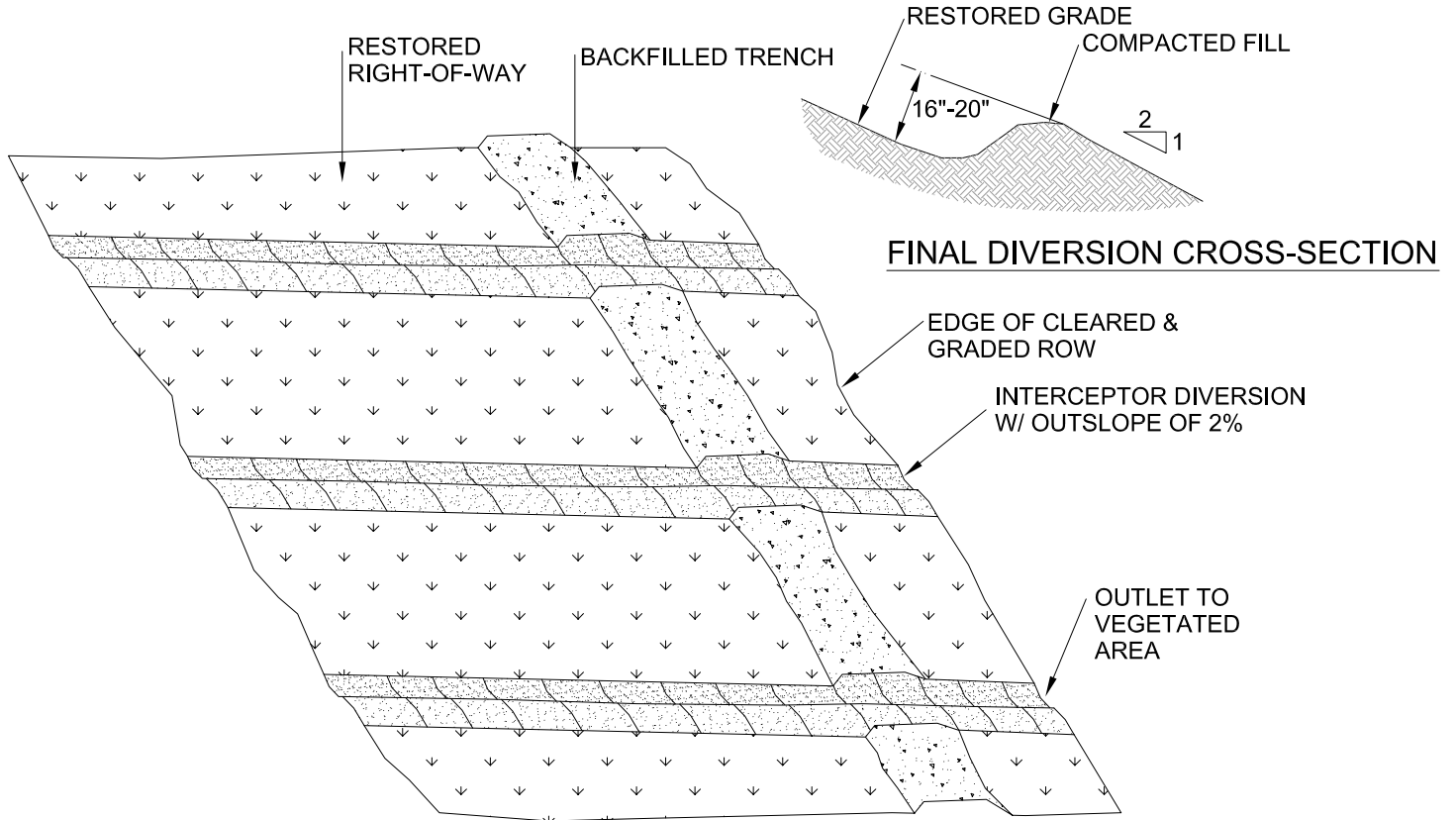

### INTERCEPTOR SPACING

ALLUVIAL SOILS		UPLAND SOILS	
SLOPE	SPACING	SLOPE	SPACING
0-25%	NONE	0-45%	NONE
25-35%	200 FEET	45-80%	200 FEET
35-75%	100 FEET	80-100%	100 FEET
>75%	75 FEET	>100%	75 FEET

SOURCE: PRELIMINARY RECLAMATION PLAN, YELLOWSTONE PIPELINE COMPANY BITTERROOT RANGE PROJECT BY: WESTECH JULY 18, 1997

**NOTE 1:** SPACING USED FOR BOTH TEMPORARY AND FINAL INTERCEPTOR DIVERSIONS

**NOTE 2:** TEMPORARY INTERCEPTOR DIVERSIONS WILL BE MAINTAINED DURING THE CONSTRUCTION PHASE UNTIL FINAL INTERCEPTOR DIVERSIONS ARE INSTALLED.

**NOTE 3:** IF EXISTING GROUND COVER IS SPARSE, SECURE SEDIMENT FILTER DEVICE IN OUTLET.

**NOTE 4:** THE DIVERSION MAY BE EXTENDED UP TO 5 FEET OFF ROW, IF NECESSARY TO PROVIDE AN ADEQUATE OUTLET.

**NOTE 5:** DIVERSION OUTLETS WILL ALTERNATE FROM SIDE TO SIDE WHENEVER POSSIBLE.

REVISIONS							TYPICAL CONSTRUCTION DETAIL		
NO.	DESCRIPTION	BY	DATE	CHK	DATE	APR	PIPELINE CONSTRUCTION DETAIL TYPICAL WATER BAR DETAIL		
A	-	-	-	-	-	-	SCALE: NONE	DWG. NUMBER: <b>STD-R003</b>	REV: <b>A</b>

Plot Date: 7/13/2009 12:51:18 PM Plot By: Chuck Haas File Name: D:\00000000000000000000\lane\frantz\Std-R003.dwg

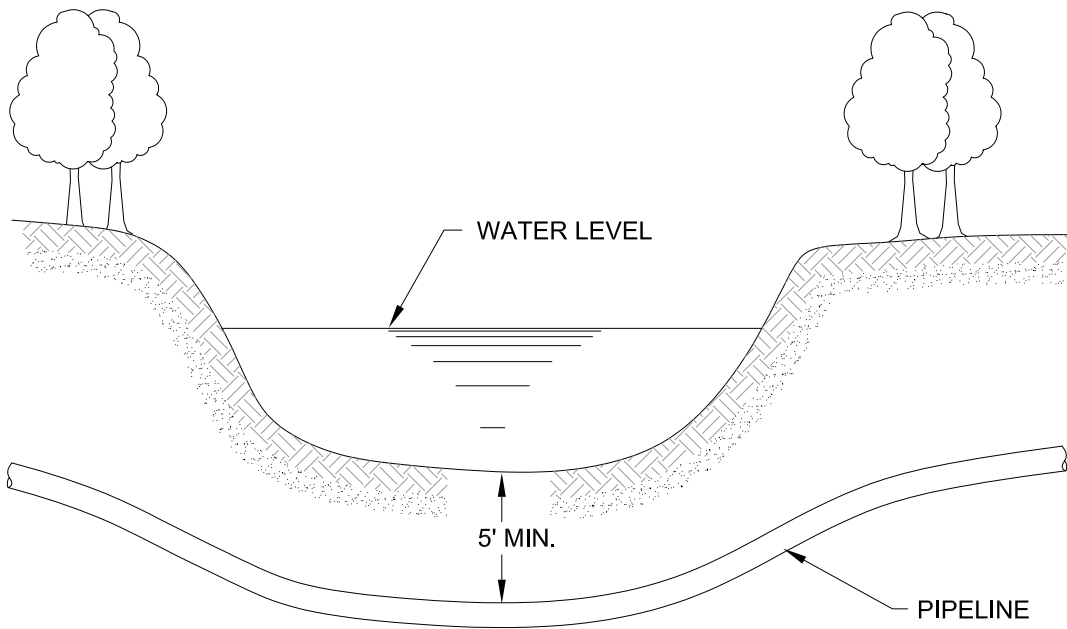

MUD, CLAY OR SAND BOTTOM

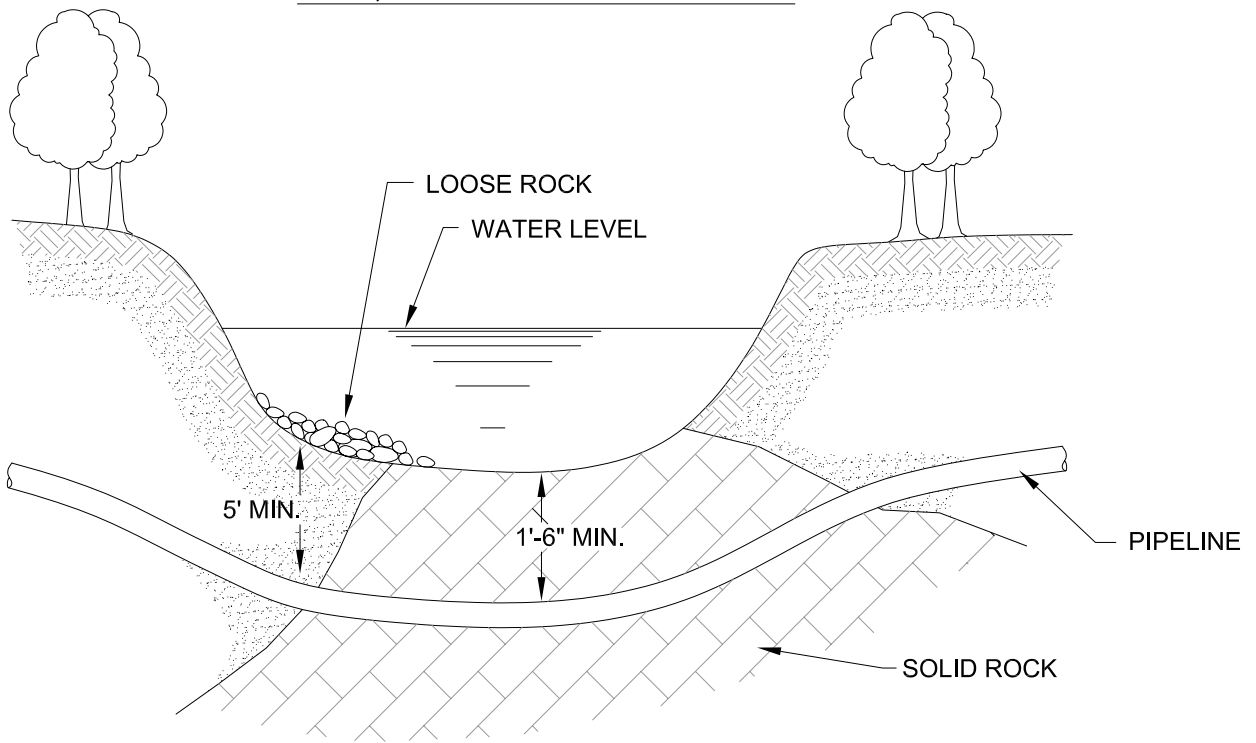

ROCK BOTTOM

Plot Date: 7/13/2009 12:59:06 PM Plot By: Chuck Haas File Name: D:\000000000000000000\lane\frantz\Std-R013.dwg

REVISIONS							
NO.	DESCRIPTION	BY	DATE	CHK	DATE	APR	DATE
A	-	-	-	-	-	-	-

TYPICAL CONSTRUCTION DETAIL

PIPELINE SPECIFICATION  
TYPICAL CROSSING  
MINOR WATER COURSE DETAIL

SCALE: NONE

DWG. NUMBER: **STD-R013**

REV: **A**

PIPELINE MARKER

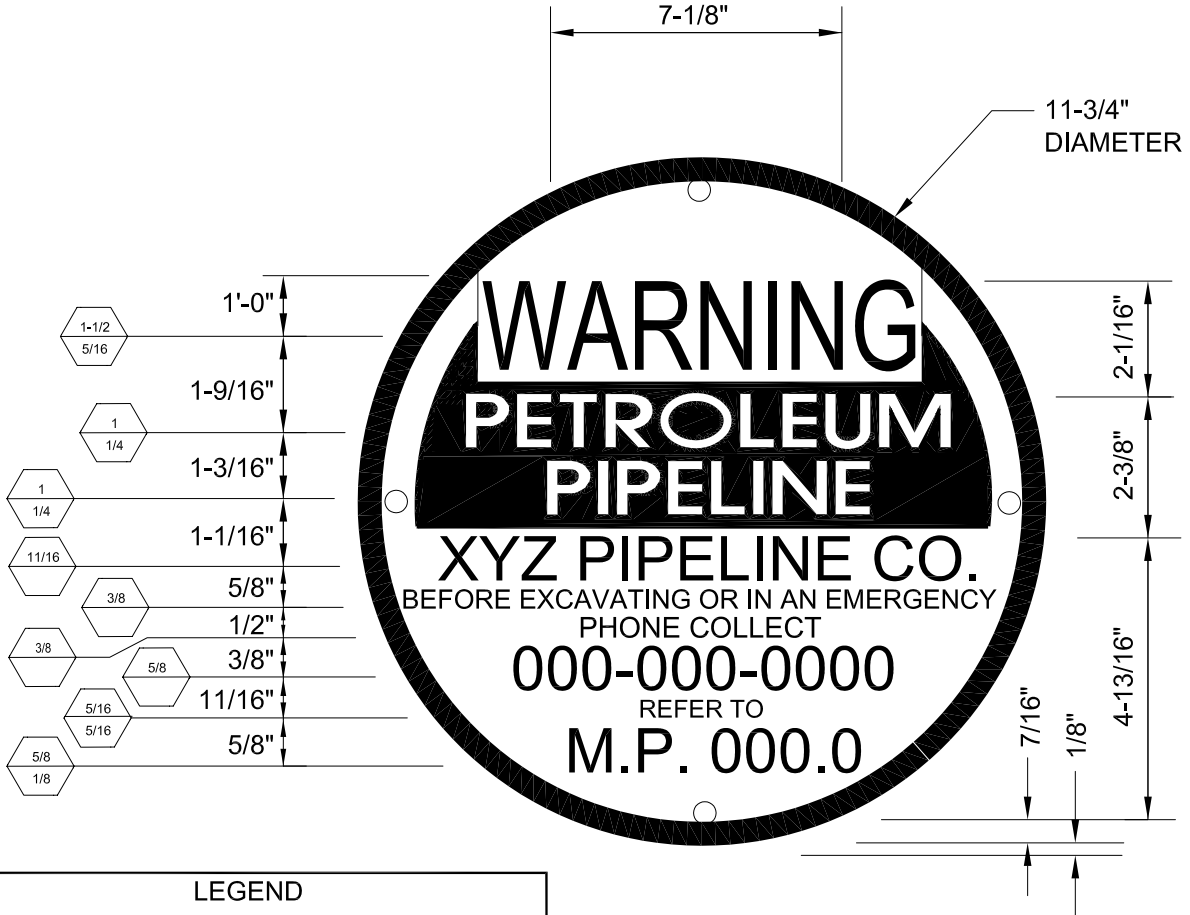

**LEGEND**

LETTER HEIGHT (IN INCHES)  
 CENTER OF LETTERS  
 STROKE WIDTH (IN INCHES)

— BLACK  
 — YELLOW  
 — RED

NOTE:

SIGN TO HAVE 4-5/16" HOLES ON 9-1/4" B.C. AT VERT. AND 9" HORIZ. CENTERLINES.

COLOR CODE:

**3M SCOTCHCAL  
COLOR LINE PAINTS**

BLACK - SERIES 3905  
 YELLOW - SERIES 4000  
 RED - SERIES 3972

**SHERWIN - WILLIAMS  
SCREEN PROCESS INK**

BLACK  
 CHROME YELLOW D22Y6  
 FIRE RED D22R9 OR D25R4  
 OR EQUIVALENT

**PRATT - LAMBERT  
EFFECTO PAINT**

BLACK NOXIDE ENAMEL NO. 16  
 VERONA YELLOW NO. 5572  
 CARNIVAL RED NO 6533 3

REVISIONS						
NO.	DESCRIPTION	BY	DATE	CHK	DATE	APR

TYPICAL CONSTRUCTION DETAIL		
ROUND WARNING SIGN		
SCALE: NONE	DWG. NUMBER: <b>STD-S001</b>	REV: <b>A</b>

Plot Date: 7/13/2009 1:09:28 PM Plot By: Chuck Haas File Name: D:\0000000000000000\planfrantz\Std-S001.dwg

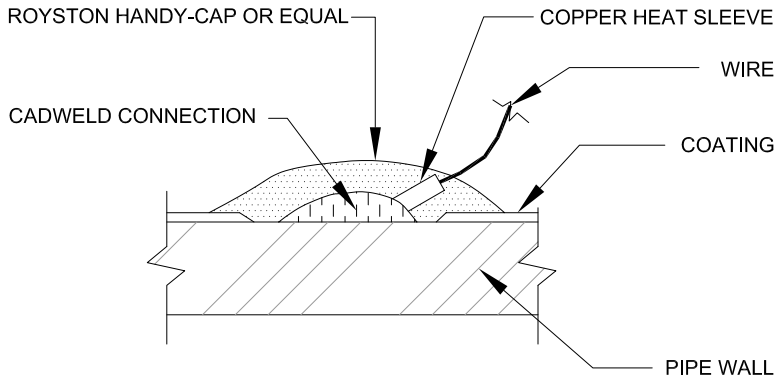

**PIPE CONNECTION DETAIL**

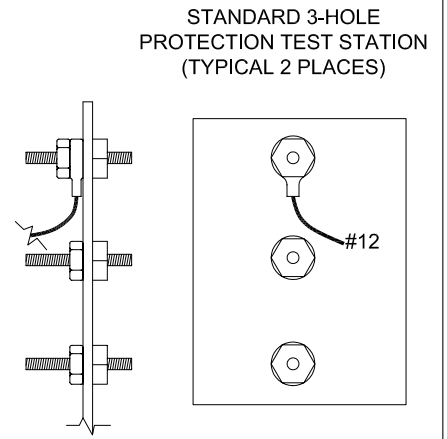

**TERMINAL DETAIL**

PIPELINE MARKER SHALL BE COTT  
"LITTLE FINK" C.P. TEST STATION/MARKER  
COMBINATION OR EQUAL SEE TERMINAL DETAIL

GRADE

LEAD SHALL MAKE AT LEAST (2) TWO  
COMPLETE LOOPS OF PIPE.

INSULATION

C/L PIPE

ATTACHMENT POINT SHALL BE MADE AT THE EXPOSED END  
OF A JOINT TO PREVENT DAMAGE TO THE INSULATION,  
SEE PIPE CONNECTION DETAIL.

4' MIN.

2' MIN.

AS SPECIFIED

#12 SOLID BLACK WIRE

REVISIONS

NO.	DESCRIPTION	BY	DATE	CHK	DATE	APR	DATE
A	-	-	-	-	-	-	-

TYPICAL CONSTRUCTION DETAIL

PIPELINE SPECIFICATION DETAIL  
POTENTIAL CATHODIC PROTECTION TEST STATION

SCALE: NONE

DWG. NUMBER: **STD-T001**

REV: A

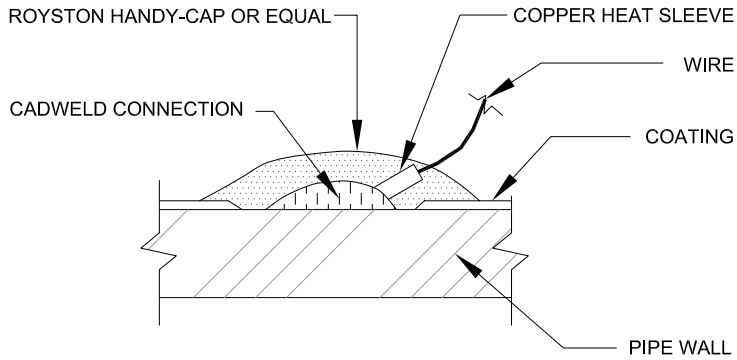

**PIPE CONNECTION DETAIL**

(SEE NOTE 2, 3 & 4)  
NOTES FROM DRAWING STD-T004

**STANDARD 3-HOLE PROTECTION TEST STATION (TYP. 2 PLACES)**

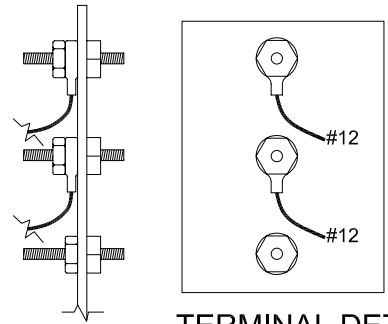

**TERMINAL DETAIL**

PIPELINE MARKER SHALL BE "LITTLE FINK"  
C.P. TEST STATION/MARKER COMBINATION  
OR EQUAL, SEE TERMINAL DETAIL.

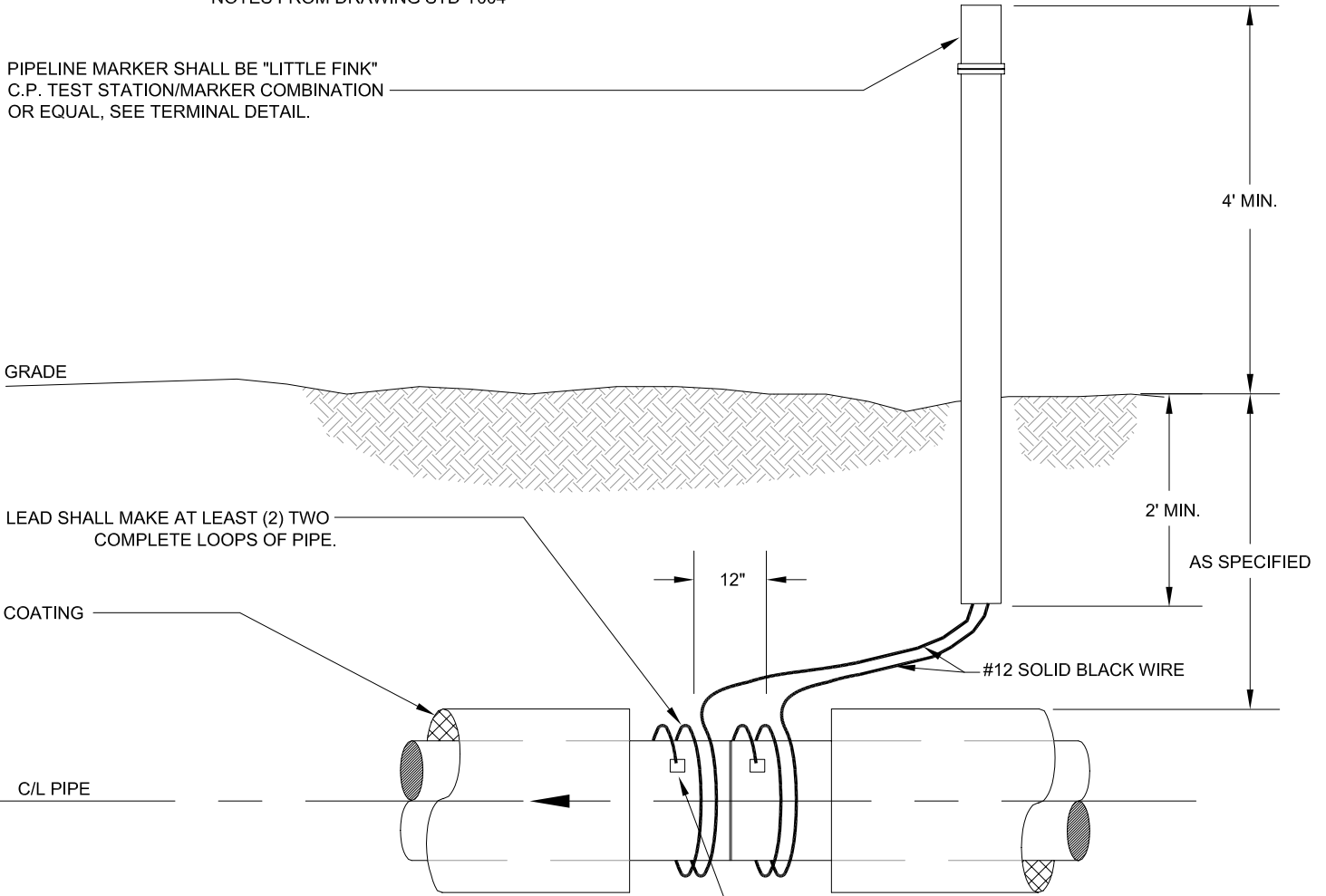

**NOTES:**

1. ALL #12 WIRES SHALL BE INSULATED COPPER SOLID THW. TYPE.
2. ALL WIRE CONNECTIONS TO CARRIER PIPE SHALL BE MADE AS SHOWN IN DETAIL. WIRE SHALL BE CONNECTED TO PIPE BY CADWELD PROCESS WITH COPPER HEAT SLEEVE.
3. CADWELD WIRE CONNECTIONS SHALL BE PRIMED WITH ROYSTON SPRAY PRIMER OR EQUAL AND ALLOWED TO DRY 3 TO 4 MINUTES OR UNTIL TACKY, AND COVERED WITH ROYSTON HANDY-CAP OR EQUAL.
4. WIRE INSULATION SHALL BE PROTECTED FROM DAMAGE.
5. CATHODIC PROTECTION TEST STATION W/CONDUIT ONLY SHALL BE FURNISHED BY COMPANY. CONTRACTOR SHALL FURNISH ALL OTHER MATERIALS.
6. LAY WIRE ALONGSIDE PIPE, DO NOT LAY WIRE ABOVE OR BELOW PIPE.
7. INSTALL WHERE INDICATED ON ALIGNMENT SHEETS.

ATTACHMENT POINT SHALL BE MADE AT THE EXPOSED END OF A JOINT TO PREVENT DAMAGE TO THE INSULATION. SEE PIPE CONNECTION DETAIL

Plot Date: 7/13/2009 1:24:00 PM Plot By: Chuck Haas File Name: D:\0000000000000000\lanefrantz\Std-T002.dwg

REVISIONS						
NO.	DESCRIPTION	BY	DATE	CHK	DATE	APR
A	-	-	-	-	-	-

<b>POTENTIAL CATHODIC PROTECTION TEST STATION</b>		<b>TYPICAL CONSTRUCTION DETAIL</b>	
		SCALE: NONE	DWG. NUMBER: <b>STD-T002</b>
			REV: <b>A</b>

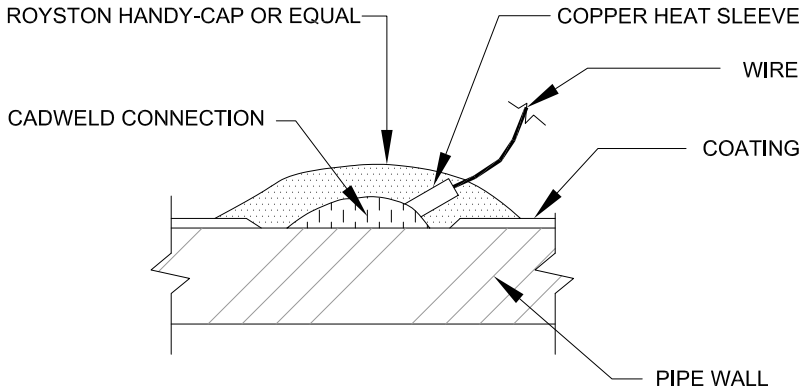

**PIPE CONNECTION DETAIL**  
(SEE NOTE 2, 3 & 4)

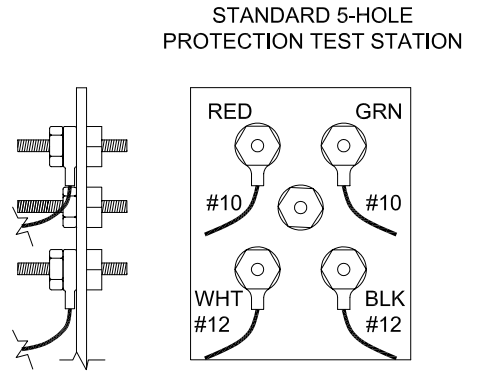

**TERMINAL DETAIL**

PIPELINE MARKER SHALL BE "BIG FINK"  
C.P. TEST STATION/MARKER COMBINATION  
OR EQUAL, SEE TERMINAL DETAIL.

CATHODIC PROTECTION TEST STATION

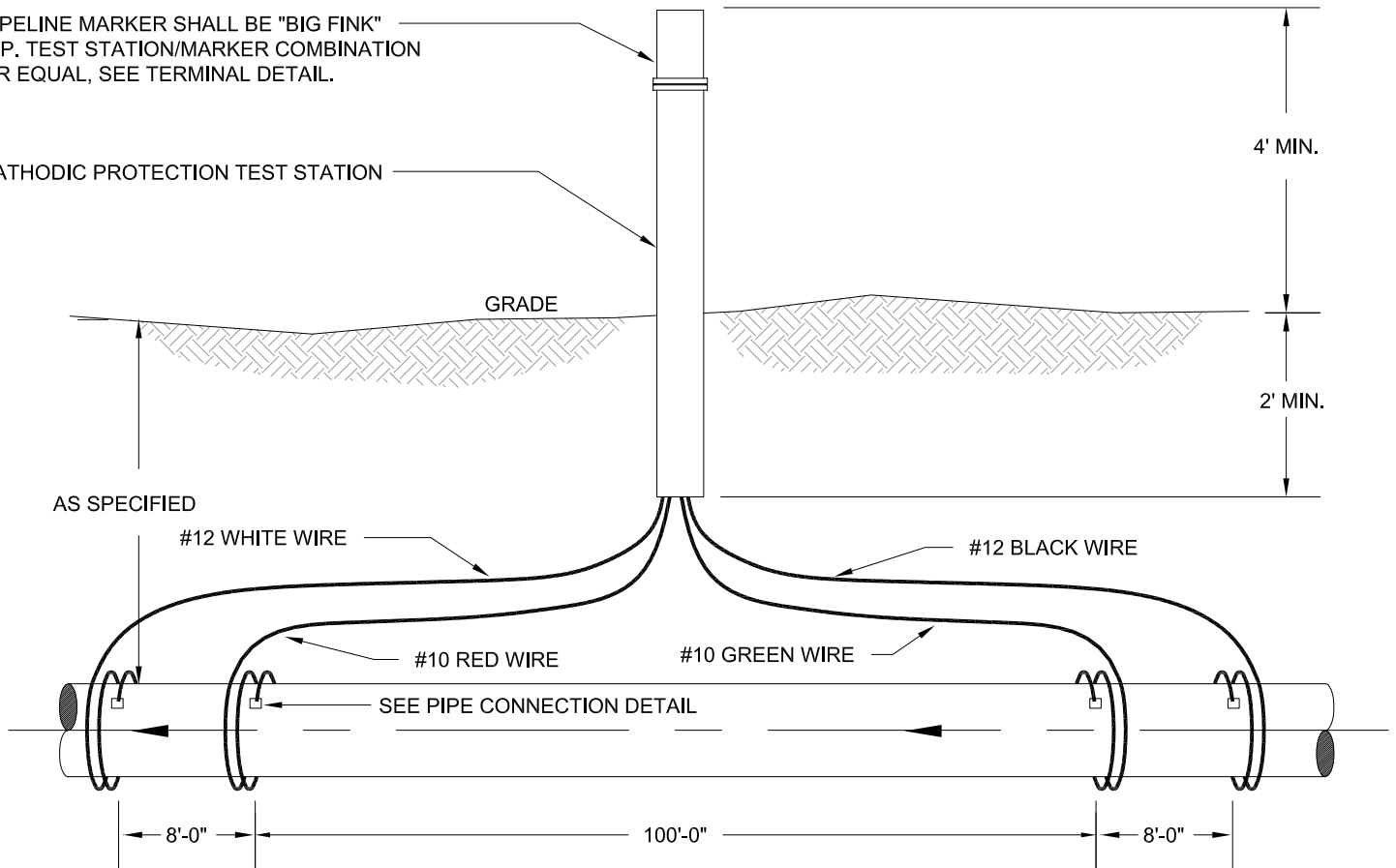

**NOTES:**

1. ALL #12 WIRES SHALL BE INSULATED COPPER SOLID THW. TYPE.
2. ALL WIRE CONNECTIONS TO CARRIER PIPE SHALL BE MADE AS SHOWN IN DETAIL. WIRE SHALL BE CONNECTED TO PIPE BY CADWELD PROCESS WITH COPPER HEAT SLEEVE.
3. CADWELD WIRE CONNECTIONS SHALL BE PRIMED WITH ROYSTON SPRAY PRIMER OR EQUAL AND ALLOWED TO DRY 3 TO 4 MINUTES OR UNTIL TACKY, AND COVERED WITH ROYSTON HANDY-CAP OR EQUAL.
4. WIRE INSULATION SHALL BE PROTECTED FROM DAMAGE.
5. CATHODIC PROTECTION TEST STATION W/CONDUIT ONLY SHALL BE FURNISHED BY COMPANY. CONTRACTOR SHALL FURNISH ALL OTHER MATERIALS.
6. LAY WIRE ALONGSIDE PIPE, DO NOT LAY WIRE ABOVE OR BELOW PIPE.
7. INSTALL WHERE INDICATED ON ALIGNMENT SHEETS.

REVISIONS						
NO.	DESCRIPTION	BY	DATE	CHK	DATE	APR
A	-	-	-	-	-	-

**TYPICAL CONSTRUCTION DETAIL**

CURRENT CORROSION  
PROTECTION TEST STATION

SCALE: NONE

DWG. NUMBER: **STD-T003**

REV: A

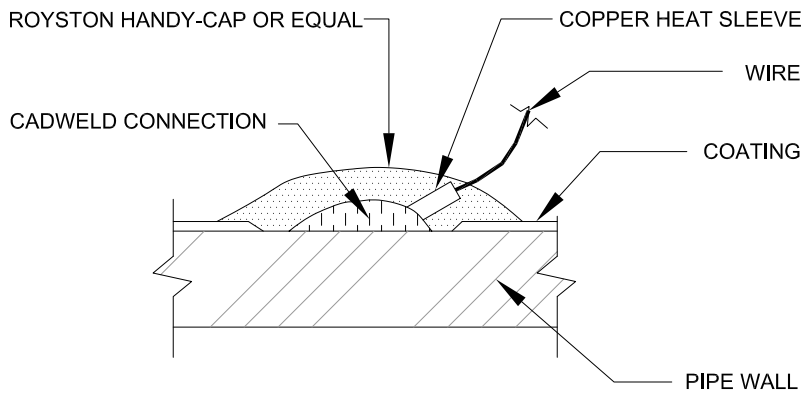

**PIPE CONNECTION DETAIL**  
(SEE NOTE 2, 3 & 4)

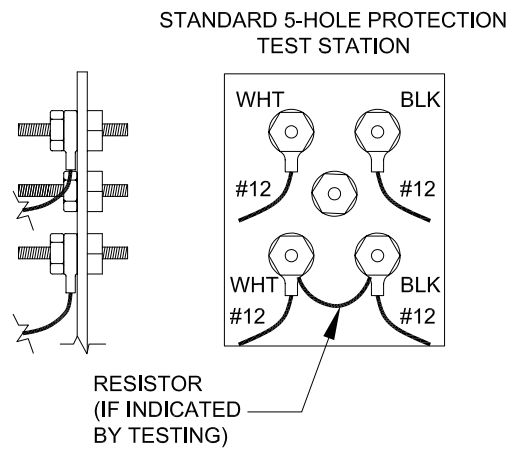

**TERMINAL DETAIL**

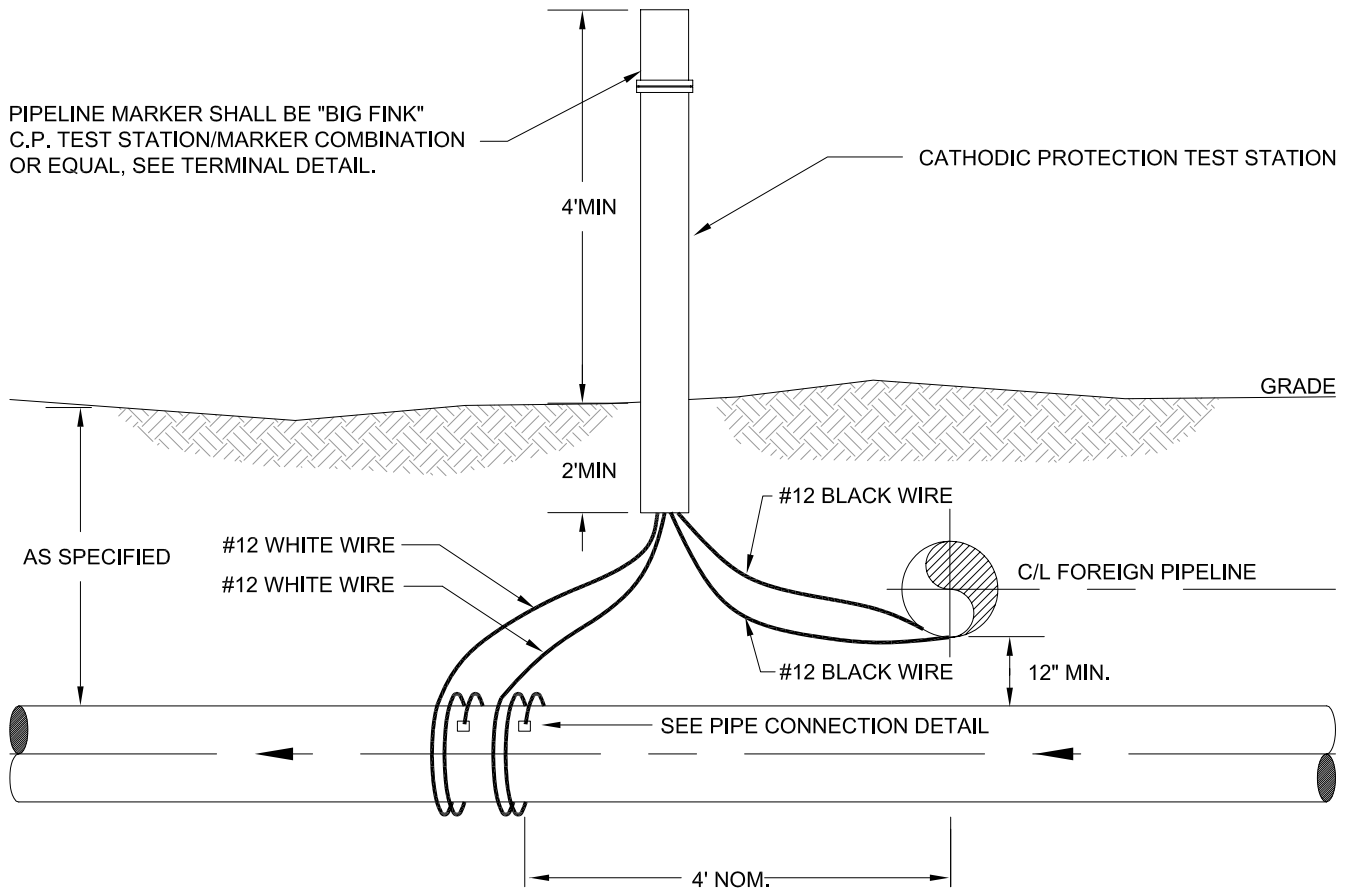

**NOTES:**

1. ALL #12 WIRES SHALL BE INSULATED COPPER SOLID THW. TYPE.
2. ALL WIRE CONNECTIONS TO CARRIER PIPE SHALL BE MADE AS SHOWN IN DETAIL. WIRE SHALL BE CONNECTED TO PIPE BY CADWELD PROCESS WITH COPPER HEAT SLEEVE.
3. CADWELD WIRE CONNECTIONS SHALL BE PRIMED WITH ROYSTON SPRAY PRIMER OR EQUAL AND ALLOWED TO DRY 3 TO 4 MINUTES OR UNTIL TACKY, AND COVERED WITH ROYSTON HANDY-CAP OR EQUAL.
4. WIRE INSULATION SHALL BE PROTECTED FROM DAMAGE.
5. CATHODIC PROTECTION TEST STATION W/CONDUIT ONLY SHALL BE FURNISHED BY COMPANY. CONTRACTOR SHALL FURNISH ALL OTHER MATERIALS.
6. LAY WIRE ALONGSIDE PIPE, DO NOT LAY WIRE ABOVE OR BELOW PIPE.
7. INSTALL WHERE INDICATED ON ALIGNMENT SHEETS.

REVISIONS						
NO.	DESCRIPTION	BY	DATE	CHK	DATE	APR
A	-	-	-	-	-	-

**TYPICAL CONSTRUCTION DETAIL**

FOREIGN LINE CROSSING  
CORROSION PROTECTION TEST STATION

SCALE: NONE

DWG. NUMBER: **STD-T004**

REV: **A**

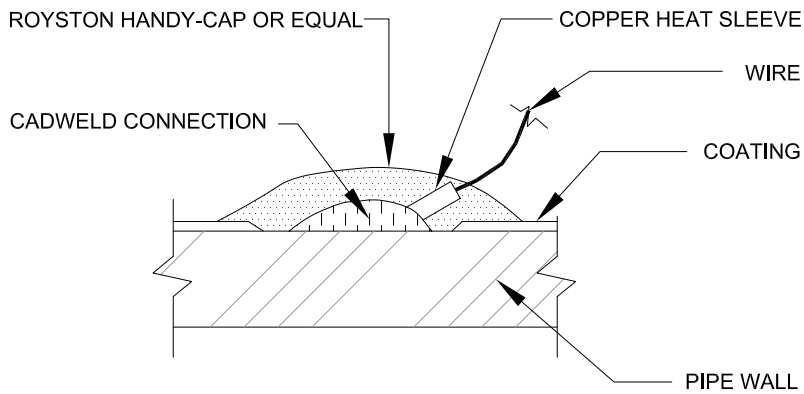

**PIPE CONNECTION DETAIL**  
(SEE NOTE 2, 3 & 4)

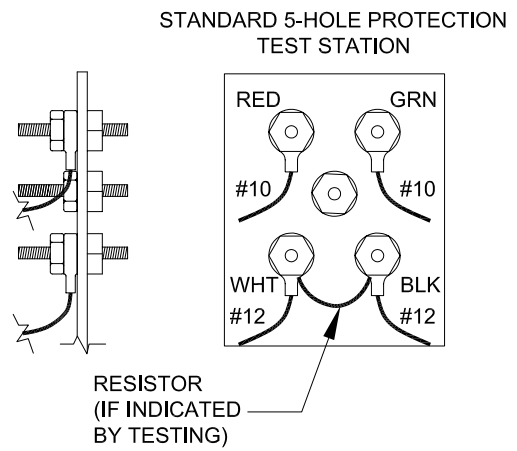

**TERMINAL DETAIL**

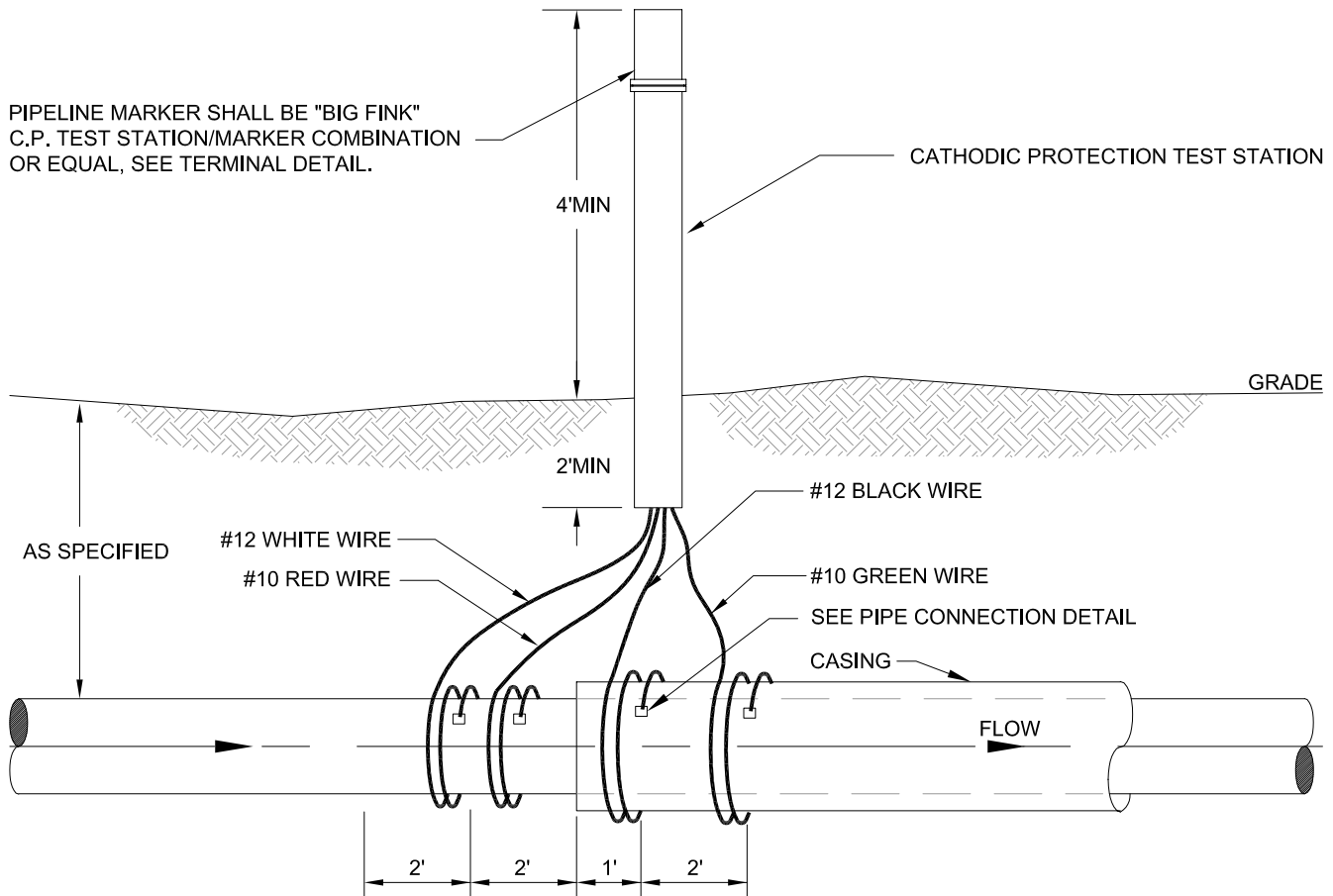

**NOTES:**

1. ALL #12 WIRES SHALL BE INSULATED COPPER SOLID THW. TYPE.
2. ALL WIRE CONNECTIONS TO CARRIER PIPE SHALL BE MADE AS SHOWN IN DETAIL. WIRE SHALL BE CONNECTED TO PIPE BY CADWELD PROCESS WITH COPPER HEAT SLEEVE.
3. CADWELD WIRE CONNECTIONS SHALL BE PRIMED WITH ROYSTON SPRAY PRIMER OR EQUAL AND ALLOWED TO DRY 3 TO 4 MINUTES OR UNTIL TACKY, AND COVERED WITH ROYSTON HANDY-CAP OR EQUAL.
4. WIRE INSULATION SHALL BE PROTECTED FROM DAMAGE.
5. CATHODIC PROTECTION TEST STATION W/CONDUIT ONLY SHALL BE FURNISHED BY COMPANY. CONTRACTOR SHALL FURNISH ALL OTHER MATERIALS.
6. LAY WIRE ALONGSIDE PIPE, DO NOT LAY WIRE ABOVE OR BELOW PIPE.
7. INSTALL WHERE INDICATED ON ALIGNMENT SHEETS.

REVISIONS						
NO.	DESCRIPTION	BY	DATE	CHK	DATE	APR
A	-	-	-	-	-	-

<b>TYPICAL CONSTRUCTION DETAIL</b>		
CASED CROSSING CATHODIC TEST STATION		
SCALE: NONE	DWG. NUMBER: <b>STD-T006</b>	REV: <b>A</b>

Plot Date: 7/13/2009 1:48:27 PM Plot By: Chuck Haas File Name: D:\0000000000000000\planfrantz\Std-T006.dwg

### CASED CROSSING (UPSTREAM)

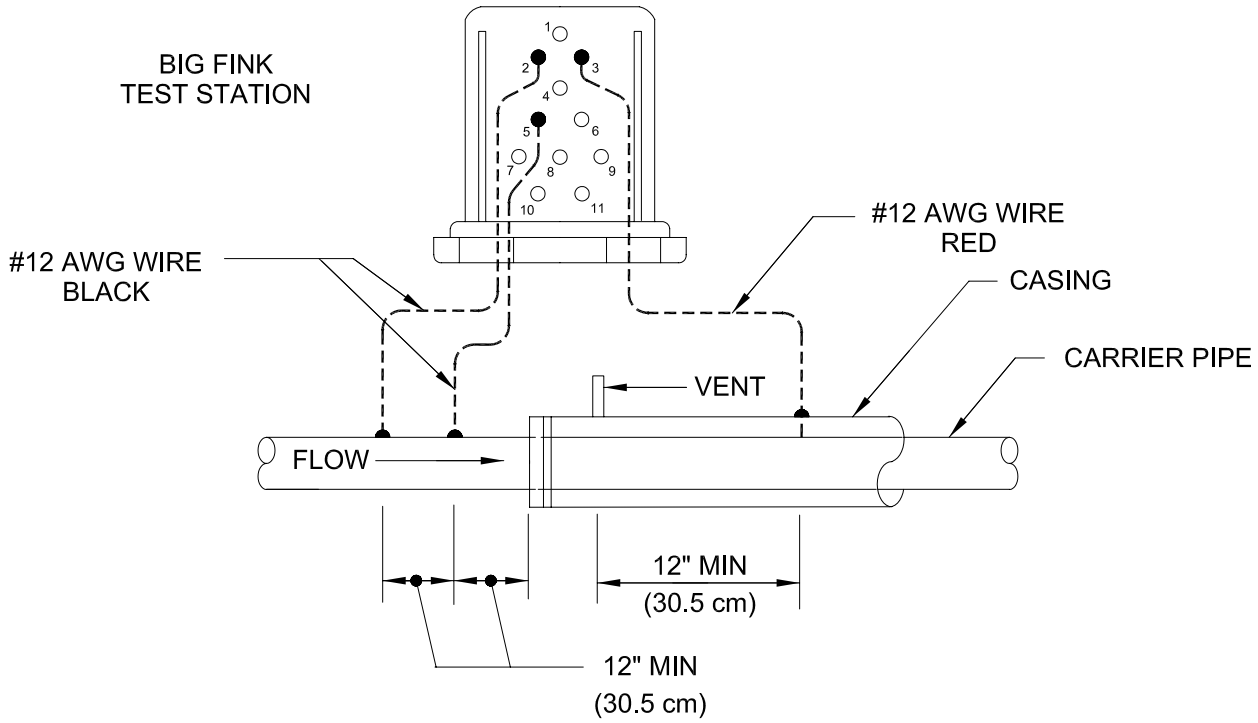

### CASED CROSSING (DOWNSTREAM)

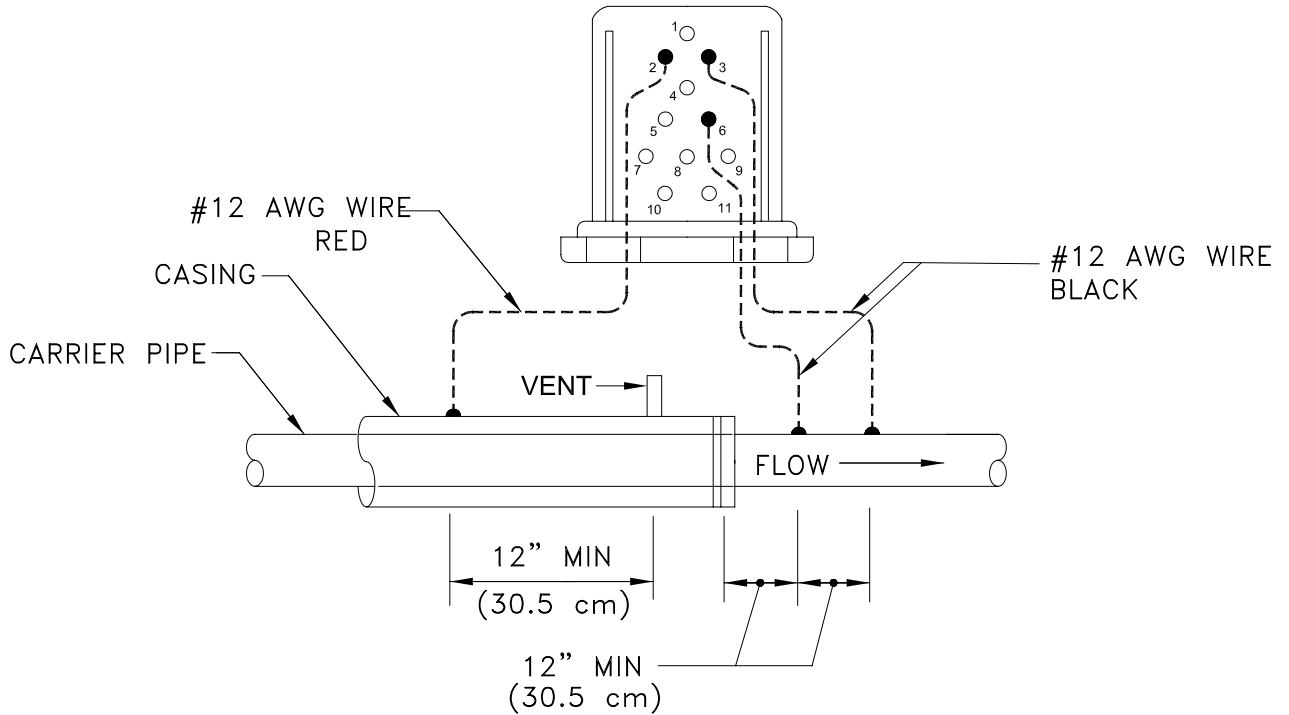

REVISIONS

NO.	DESCRIPTION	BY	DATE	CHK	DATE	APR	DATE
A	-	-	-	-	-	-	-

TYPICAL CONSTRUCTION DETAIL

CP TEST STATION  
CASED 4-WIRE

SCALE: NONE

DWG. NUMBER: **STD-T007**

REV: A

# IR DROP

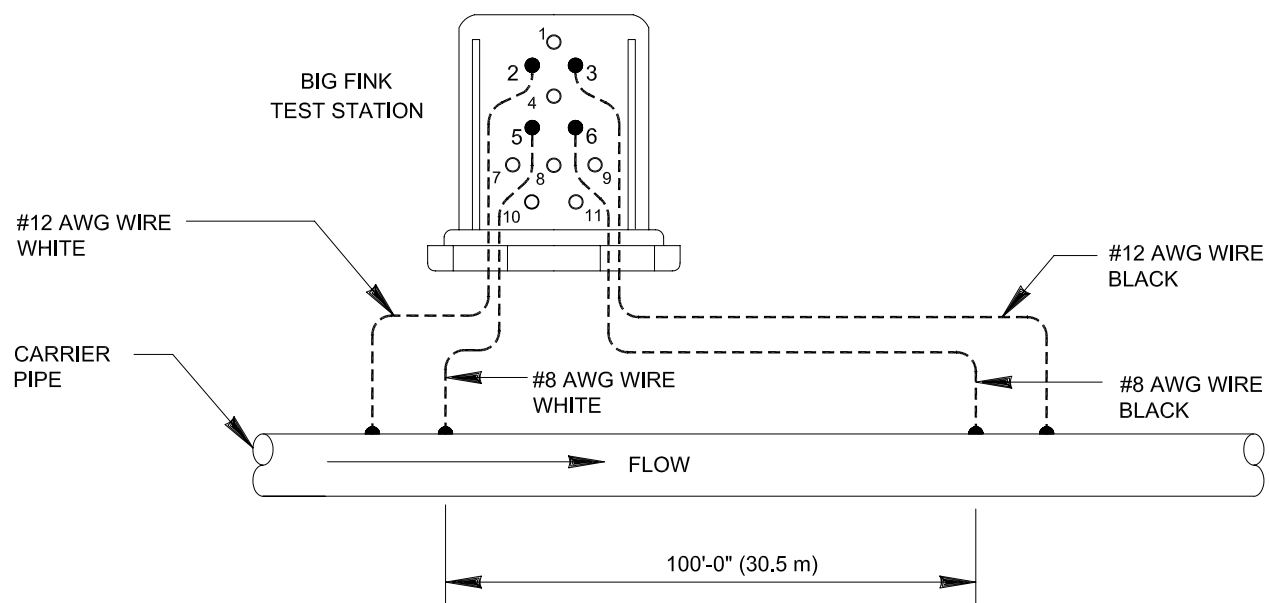

Plot Date: 7/13/2009 2:18:23 PM Plot By: Chuck Haas File Name: D:\0000000000000000\pansfrantz\Std-T008.dwg

REVISIONS							
NO.	DESCRIPTION	BY	DATE	CHK	DATE	APR	DATE
A	-	-	-	-	-	-	-

TYPICAL CONSTRUCTION DETAIL	
CP TEST STATION CURRENT 4-WIRE	
SCALE: NONE	DWG. NUMBER: <b>STD-T008</b> REV: <b>A</b>

# FOREIGN LINE CROSSING

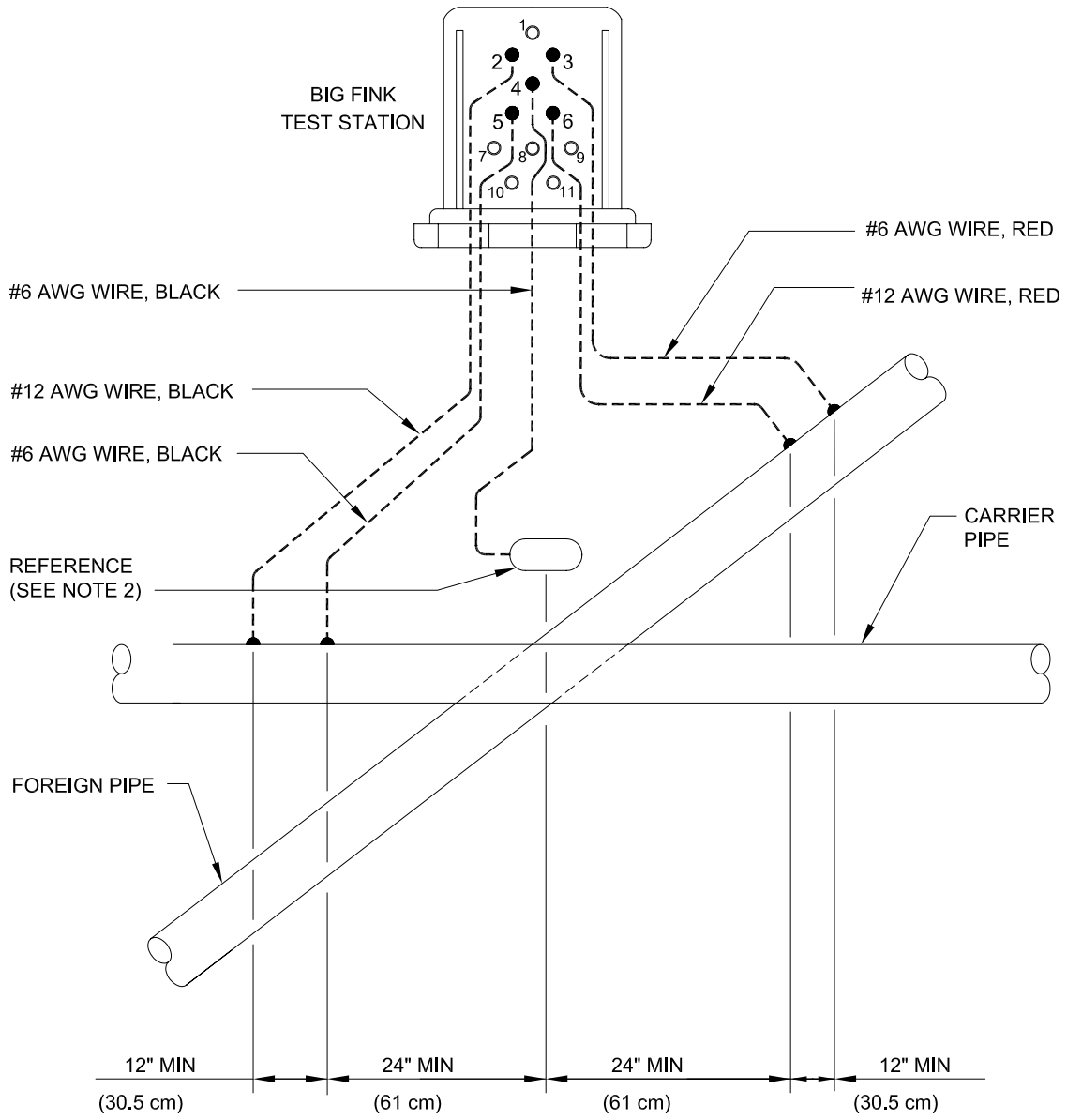

**NOTES:**

1. CONTACT FOREIGN LINE OPERATOR AND OBTAIN PERMISSION PRIOR TO CONNECTING TEST WIRES.
2. USE OF A REFERENCE IS OPTIONAL, BUT STRONGLY RECOMMENDED.
3. PLACE COMPANY FURNISHED REFERENCE DIRECTLY BETWEEN FOREIGN LINE AND CARRIER PIPE, INSTALL PER MANUFACTURERS INSTRUCTIONS.

Plot Date: 7/13/2009 2:21:37 PM Plot By: Chuck Haas File Name: D:\000000000000000000\planfrantz\Std-T009.dwg

REVISIONS							TYPICAL CONSTRUCTION DETAIL			
NO.	DESCRIPTION	BY	DATE	CHK	DATE	APR	DATE	CP TEST STATION FOREIGN LINE 4-WIRE		
A	-	-	-	-	-	-	-	SCALE: NONE	DWG. NUMBER: <b>STD-T009</b>	REV: <b>A</b>

## BURIED INSULATING FLANGE OR JOINT

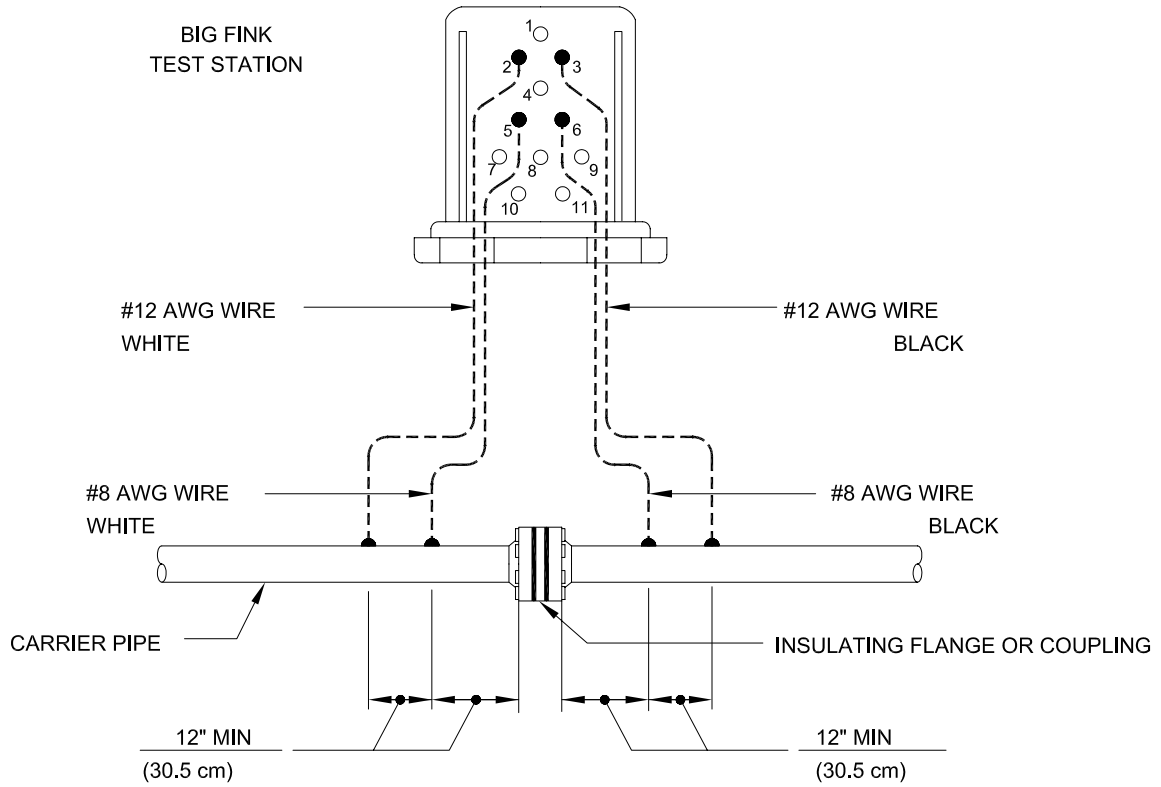

**NOTES:**

1. MAY BE ADAPTED TO ABOVE GROUND INSULATING JOINTS.
2. WHITE WIRES SHALL BE POSITIONED ON THE NORTH OR EAST SIDE OF THE INSULATOR, BLACK ON THE SOUTH OR WEST.
3. AT TERMINATION POINTS SUCH AS REFINERIES OR PRODUCT TERMINALS, BLACK WIRES SHALL BE ON THE PIPELINE SIDE, WHITE WIRES ON THE REFINERY OR TERMINAL SIDE.

Plot Date: 7/13/2009 2:26:49 PM Plot By: Chuck Haas File Name: D:\0000000000000000\pantantz\Std-T010.dwg

REVISIONS							
NO.	DESCRIPTION	BY	DATE	CHK	DATE	APR	DATE
A	-	-	-	-	-	-	-

TYPICAL CONSTRUCTION DETAIL	
CP TEST STATION INSULATING	
SCALE: NONE	DWG. NUMBER: <b>STD-T010</b>   REV: <b>A</b>

## STRUCTURE TO SOIL POTENTIAL IR DROP

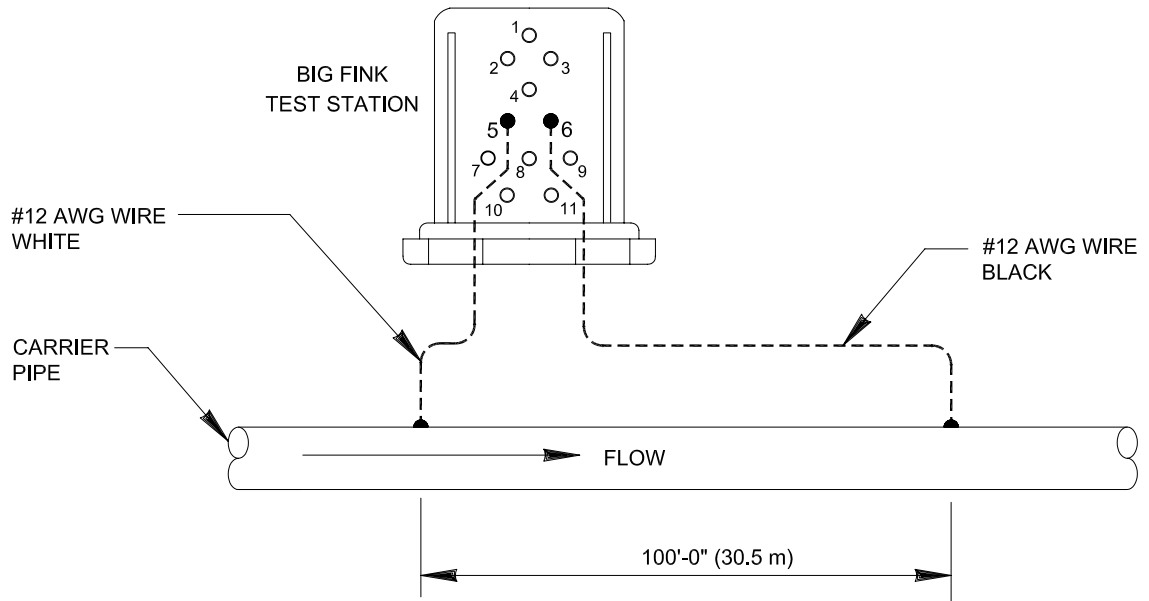

REVISIONS

NO.	DESCRIPTION	BY	DATE	CHK	DATE	APR	DATE
A	-	-	-	-	-	-	-

TYPICAL CONSTRUCTION DETAIL

CP TEST STATION  
POTENTIAL 2-WIRE

SCALE: NONE

DWG. NUMBER: **STD-T011**

REV: A