

June 7, 2012

RECEIVED

JUN 07 2012

PUBLIC SERVICE COMMISSION

Darrell Nitschke
Executive Secretary
Public Service Commission
600 East Boulevard Avenue –Dept. 408
Bismarck, ND 58505-0480

Dear Mr. Nitschke

Enclosed are Revisions to the North Dakota P.S.C. Price Schedule No. 2 for the Halstad Telephone Company. The revisions are those required pursuant to the FCC "ICC Reform Order" as referenced in the Public Service Commission letter to ND Local Exchange Companies dated May 3, 2012.

The effective date of the filing is July 1, 2012.

An attachment to this filing includes information requested by the Commission in their May 3, 2012 letter regarding existing rates, demand and the calculation of proposed access rates. The rates as filed assume no transition to Interstate LTR structure for Intrastate Access.

Questions related to this filing may be addressed to me at 651-621-8631.

Sincerely,



Patrick D. Holton
Telecommunications Consultant

Enclosures

cc: Tom Maroney Maroney, Halstad Telephone Company

1 **PU-12-260** Filed: 6/7/2012 Pages: 157
**Revisions to the North Dakota Access price
schedule No. 2**

MLGC, LLC

Patrick Holton

ACCESS SERVICE TARIFF

SECTION 10. RATES

A. GENERAL

This tariff sets forth the service offerings, rates, terms and conditions applicable to the furnishing of Intrastate Access services by Halstad Telephone Company between points within the State of North Dakota.

	<u>Recurring Unit#</u> <u>Rate</u>	
B. CARRIER COMMON LINE RATES#		
1. Originating	\$.040355/MOU	
2. Terminating	\$.021714/MOU	(R)
C. SWITCHED ACCESS SERVICE RATES#		
Tandem Switched Transport		
1) Tandem Switched Facility Rate per minute, Per Mile		(C,T)
Originating	\$.000518	
Terminating	\$.000518	
2) Tandem Switched Termination Rate per minute, Per Termination		
Originating	\$.004697	
Terminating	\$.004697	
Local Switching		
1) Local End Office Switching Rate per LS Minute ##		
Originating	\$.034038	
Terminating	\$.034038	
2) Information Surcharge Rate per LS Minute		
Originating	\$.000226	
Terminating	\$.000226	
3) Transitional Interconnection charge per Term Minute	\$.000000	
Grand fathered Unified Contractual Rate	\$.0475	(C,T)

	<u>Non-Recurring Charge</u> <u>(NRC)</u>	<u>Recurring Unit#</u> <u>Rate</u>
D. SPECIAL ACCESS RATES		
1. Special Access Metallic		
a. Channel Termination		\$ 24.58
b. Channel Mileage Facility		\$ 35.37/Mile
c. Channel Mileage Term – Per Term		\$ 2.47
d. Bridging, Per Port		
Installation, CMT – Per Term	\$230.00	
Installation, Per Thru Circuit	\$230.00	
e. Access Order Charge	\$136.00	
2. Special Access Telegraph Grade		
a. Channel Termination		
Two-Wire		\$ 24.58
Four-Wire		\$ 49.17
b. Channel Mileage Facility		\$ 2.94/Mile
c. Channel Mileage Termination		\$ 29.56
d. Bridging, Per Port		\$ 6.50

See Section 10 J for VoIP – PSTN Rates

Including Line Termination in previous tariff

Filing Date (enter w/leading 1):

Holding Company: Haislad Telephone Company - CLEC Operation

Filing Name: Haislad Telephone Company - CLEC Operation

Study Area (USAC Study Area Code):

Intrastate Demand PriceOut with Intrastate Rates	\$	30,824
Intrastate Demand PriceOut with Intrastate Rates	\$	23,118
50% of the reduction in Transitional Intrastate Access Revenues determined pursuant to 51.907(b)(2)	\$	3,853

(Note: before adjusting by Traffic Demand and CALLS Base Factors)

Tariff Section	USOC	Intrastate	Intrastate Demand	Intrastate Demand	Intrastate Demand	50% of PriceOut Difference	7/1/2013 PriceOut	7/1/2012 PriceOut	PriceOut w/7/1/2012	Intrastate Demand			
		Rate Element	Rate Element	Rate Element	Rate Element	Rate Element	Rate Element	Rate Element	Rate Element	Rate Element			
			(A)	(B)	(C)	(D)	(E) = A * D	(F) = B * D	(G) = (F - E) / 50%	(H) = INP/UT	(I) = H * D	(J) = I - E	(K) = J - B
X.X-A		CCL PREM - TERMINATING	\$0.040355	0	-	206,681.0	8,341	-	-	(4,170)	4,488	(3,853)	-
X.X-A		CCL NPREM - TERMINATING	\$0.000000										
X.X-A		LOCAL SWITCHING SERVICE CATEGORY**											
X.X-A		LOCAL SWITCHING(S) PREM TERMINATING	\$0.034038	\$0.044802		140,939.0	4,797	6,328	766	0.034038	4,787	-	-
X.X-A		Information Surcharge	\$0.000226	\$0.000484		140,939.0	32	70	19	0.000226	32	-	-
X.X-A		Trunk (CCL) NPREM TERMINATING	\$0.000000	\$0.000000		140,939.0	-	-	-	-	-	-	-
X.X-A		Grandfather Composite Terminating Rate (Intrastate Rate is avg composite Intrastate rate)	\$0.047500	\$0.046360		357,731.0	16,992	16,564	(204)	0.047500	16,992	-	-
X.X-A		NONRECURRING											
X.X-A		TRUNK CONVERSION CHARGE											
X.X-A		END OFFICE TO TANDEM REARRANGEMENT											
X.X-A		LOCAL SWITCHING OPT. FEAT. NRC											
X.X-A		** LOCAL SWITCHING TRUNK PORT CATEGORY**											
X.X-A		DS0 END OFFICE TRUNK PORTS											
X.X-A		DS1 END OFFICE TRUNK PORTS											
X.X-A		COMMON TRUNK PORT TERMINATING	\$0.000000	\$0.000000									
X.X-A		** TANDEM SWITCHED TRANSPORT SERVICE CATEGORY**											
X.X-A		TANDEM SW TERM. TERMINATING (See Composit Rate Below)	\$0.004697	\$0.002090							0.004697	-	-
X.X-A		TANDEM SW FACILITY TERMINATING (See Composit Rate Below)	\$0.000518	\$0.004002							0.000518	-	-
X.X-A		TANDEM SWITCHING TERMINATING	\$0.000000	\$0.000000									
X.X-A		TANDEM SW Transport TERMINATING (Composit Term plus Facility/Min)	\$0.004697	\$0.000964		140,939.0	662	136	(263)	0.004697	662	-	-
X.X-A		DED. MUX-DS3 TO DS1	\$0.000000	\$0.000000									
X.X-A		DS0 TANDEM TRUNK PORTS											
X.X-A		DS1 TANDEM TRUNK PORTS											
X.X-A		NONRECURRING											
X.X-A		ENTR. FACILITY - VOICE NRC											
X.X-A		SN FRSTP INSTALL PER LINE OR TRUNK											
X.X-A		** HIGH CAP & DDS SERVICE CATEGORY SWITCHED**											
X.X-A		DS1, DTTIEF											
X.X-A		ENTR. FAC-DS1											
X.X-A		DIRECT TRNK FIXED - DS1											
X.X-A		DIRECT TRNK PER MILE - DS1											
X.X-A		MUX - DS1 TO VOICE											
X.X-A		DS1 NONRECURRING - SWITCHED											
X.X-A		ENTR. FACILITY - DS1 NRC											
X.X-A		MUX - DS1 TO VOICE NRC											
X.X-A		DS3, DTTIEF											
X.X-A		ENTR. FAC-DS3											
X.X-A		DIRECT TRNK FIXED - DS3											
X.X-A		DIRECT TRNK PER MILE - DS3											
X.X-A		MUX - DS3 TO DS1											
X.X-A		ENTR. FACILITY - DS3 NRC											
X.X-A		ENTR. FACILITY - DS3 W/ TERM EQUIP REARR											
X.X-A		MUX - DS3 TO DS1 NRC											
X.X-A		End Office Revenue					30,824	23,118	(3,853)		26,971	(3,853)	-
X.X-A		Tandem Switched Revenue					30,162	22,962	(3,580)			(3,853)	-
X.X-A		Dedicated Switched Revenue					662	136	(263)			-	-
			\$	\$	\$	\$	\$	\$	\$	\$	\$	\$	\$
							30,824	23,118	(3,853)			(3,853)	-

June 7, 2012

Darrell Nitschke
Executive Secretary
Public Service Commission
600 East Boulevard Avenue – Dept. 408
Bismarck, ND 58505-0480

Dear Mr. Nitschke:

Enclosed is an Initial North Dakota P.S.C. Price Schedule No. 2 containing terms, conditions and rates for Intrastate Access Services for MLGC, LLC. This initial filing establishes terminating Intrastate Access rates equal to those of MLGC, LLC's Interstate access rates and is therefore in compliance with any requirements required by the FCC "ICC Reform Order" as referenced in the Public Service Commission letter to ND Local Exchange Companies dated May 3, 2012. MLGC, LLC will be applying Interstate LTR structure for its Intrastate Transport Services.

The effective date of the filing is July 1, 2012.

Questions related to this filing may be addressed to me at 651-621-8631.

Sincerely,



Patrick D. Holton
Telecommunications Consultant

Enclosures

cc: Tyler Kilde, MLGC, LLC

1 PU-12-260 Filed 06/07/2012 Pages: 154
Revisions to the North Dakota Access price schedule No. 2
MLGC, LLC
Patrick Holton

ACCESS SERVICE TARIFF

ACCESS SERVICE TARIFF

Terms and Conditions
applying to the provision of Access Service
for connection to Intrastate communications facilities
for Intrastate Customers within
the state of North Dakota as provided herein

The name, title and street address of this tariff's Issuing Officer is located on the bottom of Page 1, the Check Sheet. Access Services are provided by means of wire, fiber optics, radio or any other suitable technology or a combination thereof. The issuing carriers, to the extent that such services are on can be made available with reasonable effort, and after provision has been made for the companies telephone exchange services, will provide to the customer upon reasonable notice services offered in this tariff at rates and charges specified in Section 10 of this Tariff.

ACCESS SERVICE TARIFF

TABLE OF CONTENTS

	<u>Page</u>
Concurring Carriers... ..	2
Connecting Carriers.. ..	2
Other Participating Carriers	2
Registered Service Marks and Trademarks.....	2
Explanation of Symbols	3
Explanation of Abbreviations	3
Reference to Other Tariffs	4
Reference to Technical Publications.....	5
SECTION 1. <u>APPLICATION OF TARIFF</u>	8
SECTION 2. <u>GENERAL REGULATIONS</u>	9
SECTION 3. <u>CARRIER COMMON LINE ACCESS SERVICE</u>	48
SECTION 4. <u>END USER ACCESS SERVICE</u>	53
SECTION 5. <u>ORDERING OPTIONS FOR SWITCHED AND SPECIAL ACCESS SERVICE</u>	59
SECTION 6. <u>SWITCHED ACCESS SERVICE</u>	67
SECTION 7. <u>SPECIAL ACCESS SERVICE</u>	101
SECTION 8. <u>RESERVED FOR FUTURE USE</u>	120
SECTION 9. <u>MISCELLANEOUS SERVICES</u>	125
SECTION 10. <u>VOIP – PSTN SERVICE AVAILABILITY AND RATES</u>	134

ACCESS SERVICE TARIFF

CHECK SHEET

Title page and pages 1 to 149 inclusive of this tariff are effective as of date shown. Original and revised pages as named below contain all changes from the original tariff that are in effect on the date hereof.

<u>Page</u>	<u>Revision</u>	<u>Effective Date</u>
-------------	-----------------	-----------------------

Tyler Kilde, General Manager
MLGC, LLC
301 Dewey Street
ENDERLIN, ND, 58027
701-921-8564

ACCESS SERVICE TARIFF

CONCURRING CARRIERS

None

CONNECTING CARRIERS

None

OTHER PARTICIPATING CARRIERS

None

REGISTERED SERVICE MARKS AND TRADEMARKS

None

ACCESS SERVICE TARIFF

EXPLANATION OF SYMBOLS

- (C) - To signify changed regulation
- (D) - To signify discontinued rate or regulation
- (I) - To signify increase
- (M) - To signify matter relocated without change
- (N) - To signify new rate or regulation
- (R) - To signify reduction
- (S) - To signify reissued matter
- (T) - To signify a change in text but no change in rate or regulation
- (Z) - To signify a correction

EXPLANATION OF ABBREVIATIONS

- ac - Alternating Current
- AML - Actual Measured Loss
- ANI - Automatic Number Identification
- AT&T - American Telephone and Telegraph Company
- BHMC - Busy Hour Minutes of Capacity
- CCS - Hundred Call Seconds
- CO - Central Office
- Cont. - Continued
- CN - Charge Number
- CPE - Customer Premises Equipment
- DA - Directory Assistance
- dB - Decibel
- dBrnC - Decibel Reference Noise C-Message Weighting
- dBrnCO - Decibel Reference Noise C-Message Weighted O
- dBv - Decibel(s) Relative to 1 Volt (Reference)
- dBvl - Decibel(s) Relating to 1 Volt (Reference)
- dc - Direct Current
- EDD - Envelope Delay Distortion
- ELEPL - Equal Level Echo Path Loss
- EML - Expected Measured Loss
- EPL - Echo Path Loss

ACCESS SERVICE TARIFF

EXPLANATION OF ABBREVIATIONS (Cont.)

ERL	-	Echo Return Loss
ETV	-	Educational Television
F.C.C.	-	Federal Communications Commission
FX	-	Foreign Exchange
IC	-	Intrastate Customer
ICL	-	Inserted Connection Loss
Kbps	-	Kilobits Per Second
kHz	-	Kilohertz
LATA	-	Local Access and Transport Area
ma	-	Milliamperes
Mbps	-	Megabits Per Second
MHz	-	Megahertz
MTS	-	Message Telecommunications Service(s)
NPA	-	Numbering Plan Area
NTS	-	Non-Traffic Sensitive
NXX	-	Three-Digit Central Office Code
OTPL	-	Zero Transmission Level Point
PBX	-	Private Branch Exchange
PCM	-	Pulse Code Modulation
PL	-	Private Line
POT	-	Point of Termination
PSTN	-	Public Switched Telephone Network
PVU	-	Percent VoIP Usage
rms	-	Root-Mean-Square
SAC	-	Service Access Code
SRL	-	Singing Return Loss
SWC	-	Serving Wire Center
TDM	-	Time Division Multiplexing
TES	-	Telephone Exchange Service(s)
TLP	-	Transmission Level Point
VG	-	Voice Grade
V & H	-	Vertical and Horizontal
VoIP	-	Voice over Internet Protocol
WATS	-	Wide Area Telecommunications Service(s)

REFERENCE TO OTHER TARIFFS

Whenever reference is made in this Tariff to other tariffs of the Telephone Company, the reference is to the tariffs in force as of the effective date of this Tariff, and to amendments thereto and successive issues thereof.

The following tariffs are referenced in this tariff and may be obtained as shown:

National Exchange Carrier Association
100 S. Jefferson
Whippany, NJ
Tariff FCC No. 4 & 5

ACCESS SERVICE TARIFF

REFERENCE TO TECHNICAL PUBLICATIONS

RESERVED FOR FUTURE USE

ACCESS SERVICE TARIFF

REFERENCE TO TECHNICAL PUBLICATIONS (Cont.)

RESERVED FOR FUTURE USE

ACCESS SERVICE TARIFF

REFERENCE TO TECHNICAL PUBLICATIONS (Cont.)

RESERVED FOR FUTURE USE

ACCESS SERVICE TARIFF

SECTION 1. APPLICATION OF TARIFF

- 1.1 This Tariff contains regulations, rates and charges applicable to the provision of Carrier Common Line Access, End User Access, Switched Access Services, Special Access Services, and other miscellaneous services hereinafter referred to collectively as service(s), provided by MLGC, LLC, hereinafter referred to as the Telephone Company, to customers.
- 1.2 The provision of such services by the Telephone Company as set forth in this Tariff does not constitute a joint undertaking with the customer for the furnishing of any service.

ACCESS SERVICE TARIFF

SECTION 2. GENERAL REGULATIONS

2.1 Undertaking of the Telephone Company

2.1.1 Scope

- (A) The Telephone Company does not undertake to transmit messages under this Tariff.
- (B) The Telephone Company shall be responsible only for the installation, operation and maintenance of the services which it provides.
- (C) The Telephone Company will, for maintenance purposes, routinely test its services to the extent necessary to detect and/or clear troubles.
- (D) Services are provided 24 hours daily, seven days per week, except as set forth in other applicable sections of this Tariff.
- (E) The Telephone Company does not warrant that its facilities and services meet standards other than those set forth in this Tariff.

2.1.2 Limitations

- (A) The customer may not assign or transfer the use of services provided under this Tariff except where there is no interruption of use or relocation of the services. In such cases, such assignment or transfer may be made to:
 - (1) Another customer, whether an individual, partnership, association, or corporation, provided the assignee or transferee assumes all outstanding indebtedness for such services, and the unexpired portion of the minimum period and the termination liability applicable to such services, if any; or
 - (2) A court-appointed receiver, trustee or other person acting pursuant to law in bankruptcy, receivership, reorganization, insolvency, liquidation or other similar proceedings, provided the assignee or transferee assumes the unexpired portion of the minimum period and the termination liability applicable to such services, if any.

ACCESS SERVICE TARIFF

SECTION 2. GENERAL REGULATIONS (Cont.)

2.1 Undertaking of the Telephone Company (Cont.)

2.1.2 Limitations (Cont.)

In all cases of assignment or transfer, the written acknowledgment of the Telephone Company is required prior to such assignment or transfer which acknowledgment shall be made within 15 days from the receipt of notification. All regulations and conditions contained in this Tariff shall apply to such assignee or transferee.

The assignment or transfer of services does not relieve or discharge the assignor or transferer from remaining jointly or severally liable with the assignee or transferee for any obligations existing at the time of the assignment or transfer.

- (B) The use and restoration of services shall be in accordance with Part 64, Subpart D, Appendix A, of the Federal Communications Commission's Rules and Regulations, which specifies the priority system for such activities.
- (C) Subject to compliance with the rules mentioned in (B) preceding, where a shortage of facilities or equipment exists at any time, either for temporary or protracted periods, the services offered herein will be provided to customers on a first come, first served basis.

2.1.3 Liability

- (A) With respect to any claim or suit by a customer, or by any others, for damages associated with the installation, provision, termination, maintenance, repair or restoration of service, and subject to the provisions of (B) through (G) following, the Telephone Company's liability, if any, shall not exceed an amount equal to the proportionate charge for the service for the period during which the service was affected. This liability for damages shall be in addition to any amounts that may otherwise be due the customer under this Tariff as a Credit Allowance for a Service Interruption.
- (B) The Telephone Company shall not be liable for any act or omission of any other carrier or customer providing a portion of a service, nor shall the Telephone Company for its own act or omission hold liable any other carrier or customer providing a portion of a service.

ACCESS SERVICE TARIFF

SECTION 2. GENERAL REGULATIONS (Cont.)

2.1 Undertaking of the Telephone Company (Cont.)

2.1.3 Liability (Cont.)

- (C) The Telephone Company is not liable for damages to the customer premises resulting from the furnishing of a service, including the installation and removal of equipment and associated wiring, unless the damage is caused by the Telephone Company's negligence.
- (D) The Telephone Company shall be indemnified, defended, and held harmless by the end user against any claim, loss or damage arising from the end user's use of services offered under this Tariff, involving:
 - (1) Claims for libel, slander, invasion of privacy, or infringement of copyright arising from the end user's own communications;
 - (2) Claims for patent infringement arising from the end user's acts combining or using the service furnished by the Telephone Company in connection with facilities or equipment furnished by the end users or IC or;
 - (3) All other claims arising out of any act or omission of the end user in the course of using services provided pursuant to this Tariff.
- (E) The Telephone Company shall be indemnified, defended and held harmless by the IC against any claim, loss or damage arising from the IC's use of services offered under this Tariff, involving:
 - (1) Claims for libel, slander, invasion of privacy, or infringement of copyright arising from the IC's own communications;
 - (2) Claims for patent infringement arising from the IC's acts combining or using the service furnished by the Telephone Company in connection with facilities or equipment furnished by the end user or IC or;
 - (3) All other claims arising out of any act or omission of the IC in the course of using services provided pursuant to this Tariff.

ACCESS SERVICE TARIFF

SECTION 2. GENERAL REGULATIONS (Cont.)

2.1 Undertaking of the Telephone Company (Cont.)

2.1.3 Liability (Cont.)

- (F) The Telephone Company does not guarantee or make any warranty with respect to its services when used in an explosive atmosphere. The Telephone Company shall be indemnified, defended and held harmless by the customer from any and all claims by any person relating to such customer's use of the services so provided.
- (G) No license under patents (other than the limited license to use) is granted by the Telephone Company or shall be implied or arise by estoppel, with respect to any service offered under this Tariff. The Telephone Company will defend the customer against claims of patent infringement arising solely from the use by the customer of services offered under this Tariff and will indemnify such customer for any damages awarded based solely on such claims.
- (H) The Telephone Company's failure to provide or maintain services under this Tariff shall be excused by labor difficulties, governmental orders, civil commotions, acts of God and other circumstances beyond the Telephone Company's reasonable control, subject to the Credit Allowance for a Service Interruption as set forth in 2.4.3 following.

2.1.4 Provision of Services

The Telephone Company, to the extent that such services are or can be made available with reasonable effort, and after provision has been made for the Telephone Company's telephone exchange services, will provide to the customer upon reasonable notice services offered in other applicable sections of this Tariff at rates and charges specified therein.

2.1.5 Installation and Termination of Services

The services provided under this Tariff (A) will include any entrance cable or drop wiring and wire or intra-building network cable to that point where provision is made for termination of the Telephone Company's outside distribution network facilities at a suitable location inside a customer-designated premises and (B) will be installed by the Telephone Company to such Point of Termination.

ACCESS SERVICE TARIFF

SECTION 2. GENERAL REGULATIONS (Cont.)

2.1 Undertaking of the Telephone Company (Cont.)

2.1.6 Maintenance of Services

The services provided under this Tariff shall be maintained by the Telephone Company. The customer or others may not rearrange, move, disconnect, remove or attempt to repair any facilities provided by the Telephone Company, other than by connection or disconnection to any interface means used, except with the written consent of the Telephone Company.

2.1.7 Changes and Substitutions

Except as provided for equipment and systems subject to F.C.C. Part 68 regulations at 47 C.F.R. Section 68.110(b), the Telephone Company may, where such action is lawful and reasonably required in the operation of its business, (A) substitute, change or rearrange any facilities used in providing service under this Tariff, (B) change minimum protection criteria, (C) change operating or maintenance characteristics of facilities or (D) change operations or procedures of the Telephone Company. The Telephone Company shall not be responsible if any such substitution, change or rearrangement renders any customer furnished services obsolete or requires modification or alteration thereof or otherwise affects their use or performance. If such substitution, change or rearrangement materially affects the operating characteristics of the facility, the Telephone Company will provide reasonable notification to the customer. Reasonable time will be allowed for any redesign and implementation required by the change in operating characteristics. The Telephone Company will work cooperatively with the customer to determine notification requirements.

2.1.8 Discontinuance and Refusal of Services

(A) Unless the provisions of 2.2.1(B) or 2.5 following apply, if a customer fails to comply with 2.1.6 preceding or 2.2.2, 2.3.1, 2.3.4, 2.3.5 or 2.4 following, including any payments to be made by it on the dates and times herein specified, the Telephone Company may, on thirty (30) days written notice by certified U.S. Mail to the person designated by that customer to receive such notices of noncompliance, refuse additional applications for service and/or refuse to complete any pending orders for service by the non-complying customer at any time thereafter.

ACCESS SERVICE TARIFF

SECTION 2. GENERAL REGULATIONS (Cont.)

2.1 Undertaking of the Telephone Company (Cont.)

2.1.8 Discontinuance and Refusal of Services (Cont.)

If the Telephone Company does not refuse additional applications for service on the date specified in the thirty (30) days notice, and the customer's noncompliance continues, nothing contained herein shall preclude the Telephone Company's right to refuse additional applications for service to the non-complying customer without further notice.

- (B) Unless the provisions of 2.2.1(B) or 2.5 following apply, if a customer fails to comply with 2.1.6 preceding or 2.2.2, 2.3.1, 2.3.4, 2.3.5, or 2.4 following, including any payments to be made by it on the dates and times herein specified, the Telephone Company may, on thirty (30) days written notice by Certified U.S. Mail to the person designated by that customer to receive such notices of noncompliance, discontinue the provision of the services to the non-complying customer at any time thereafter. In the case of such discontinuance, all applicable charges, including termination charges, shall become due. If the Telephone Company does not discontinue the provision of the services involved on the date specified in the thirty (30) days notice, and the customer's noncompliance continues, nothing contained herein shall preclude the Telephone Company's right to discontinue the provision of the services to the non-complying customer without further notice.

2.1.9 Notification of Service-Affecting Activities

The Telephone Company will provide the customer reasonable notification of service-affecting activities that may occur in normal operation of its business. Such activities may include, but are not limited to, equipment or facilities additions, removals or rearrangements, routine preventative maintenance and major switching machine change-out. Generally, such activities are not individual customer service specific; rather, they affect many customer services.

No specific advance notification period is applicable to all service activities. The Telephone Company will work cooperatively with the customer to determine the notification requirements.

ACCESS SERVICE TARIFF

SECTION 2. GENERAL REGULATIONS (Cont.)

2.1 Undertaking of the Telephone Company (Cont.)

2.1.10 Coordination with Respect to Network Contingencies

The Telephone Company intends to work cooperatively with the customer to develop network contingency plans in order to maintain maximum network capability following natural or man-made disasters which affect telecommunications services.

2.1.11 Provision and Ownership of Telephone Numbers

The Telephone Company reserves the right to assign, designate or change telephone numbers, any other call number designations associated with Access Services, or the Telephone Company serving central office prefixes associated with such numbers, when necessary in the conduct of its business. Should it become necessary to make a change in such number(s), the Telephone Company will furnish to the customer six (6) months notice, by Certified U.S. Mail, of the effective date and an explanation of the reason(s) for such change(s).

2.2 Use

2.2.1 Interference or Impairment

- (A) The characteristics and methods of operation of any circuits, facilities or equipment provided by other than the Telephone Company and associated with the facilities utilized to provide services under this Tariff shall not interfere with or impair service over any facilities of the Telephone Company, its affiliated companies, or its connecting and concurring carriers involved in its services, cause damage to their plant, impair the privacy of any communications carried over their facilities or create hazards to the employees of any of them or the public.
- (B) Except as provided for equipment or systems subject to the FCC Part 68 Rules in 47 C.F.R. Section 68.108, if such characteristics or methods of operation are not in accordance with (A) preceding, the Telephone Company will, where practicable, notify the customer that temporary discontinuance of the use of a service may be required; however, where prior notice is not practicable, nothing contained herein shall be deemed to preclude the Telephone Company's right to temporarily discontinue forthwith the use of a service if such action is reasonable under the circumstances. In case of such temporary discontinuance, the customer will be promptly notified and afforded the opportunity to correct the condition which gave rise to the temporary discontinuance. During such period of temporary discontinuance, credit allowance for service interruptions as set forth in 2.4.3 following is not applicable.

ACCESS SERVICE

SECTION 2. GENERAL REGULATIONS (Cont.)

2.2 Use (Cont.)

2.2.2 Unlawful Use

The service provided under this Tariff shall not be used for an unlawful purpose.

2.3 Obligations of the Customer

2.3.1 Damages

The customer shall reimburse the Telephone Company for damages to Telephone Company facilities utilized to provide services under this Tariff caused by the negligence or willful act of the customer or resulting from improper use of the Telephone Company facilities, or due to malfunction of any facilities or equipment provided by other than the Telephone Company. Nothing in the foregoing provision shall be interpreted to hold one customer liable for another customer's actions. The Telephone Company will, upon reimbursement for damages, cooperate with the customer in prosecuting a claim against the person causing such damage and the customer shall be subrogated to the right of recovery by the Telephone Company for the damages to the extent of such payment.

2.3.2 Ownership of Facilities and Theft

Facilities utilized by the Telephone Company to provide service under the provisions of this Tariff shall remain the property of the Telephone Company. Such facilities shall be returned to the Telephone Company by the customer, whenever requested, within a reasonable period following the request in as good condition as reasonable wear will permit.

2.3.3 Equipment Space and Power

The customer shall furnish or arrange to have furnished to the Telephone Company, at no charge, equipment space and electrical power required by the Telephone Company to provide services under this Tariff at the points of termination of such services. The selection of ac or dc power shall be mutually agreed to by the customer and the Telephone Company. The customer shall also make necessary arrangements in order that the Telephone Company will have access to such spaces at reasonable times for installing, testing, repairing or removing Telephone Company services.

ACCESS SERVICE TARIFF

SECTION 2. GENERAL REGULATIONS (Cont.)

2.3 Obligations of the Customer (Cont.)

2.3.4 Availability for Testing

The services provided under this Tariff shall be available to the Telephone Company at times mutually agreed upon in order to permit the Telephone Company to make tests and adjustments appropriate for maintaining the services in satisfactory operating condition. Such tests and adjustments shall be completed within a reasonable time. No credit will be allowed for any interruptions involved during such tests and adjustments.

2.3.5 Balance

All signals for transmission over the services provided under this Tariff shall be delivered by the customer balance to ground except for ground start, duplex (DX) and McCulloh-Loop (Alarm System) type signaling and dc telegraph transmission at speeds of 75 baud or less.

2.3.6 Design of Customer Services

Subject to the provisions of 2.1.7 preceding, the customer shall be solely responsible, at its own expense, for the overall design of its services and for any redesigning or rearrangement of its services which may be required because of changes in facilities, operations or procedures of the Telephone Company, minimum protection criteria or operating or maintenance characteristics of the facilities.

2.3.7 References to the Telephone Company

The customer may advise End Users that certain services are provided by the Telephone Company in connection with the service the customer furnishes to End Users; however, the customer shall not represent that the Telephone Company jointly participates in the customer's services.

ACCESS SERVICE TARIFF

SECTION 2. GENERAL REGULATIONS (Cont.)

2.3 Obligations of the Customer (Cont.)

2.3.8 Claims and Demands for Damages

- (A) With respect to claims of patent infringement made by third persons, the customer shall defend, indemnify, protect and save harmless the Telephone Company from and against all claims arising out of the combining with, or use in connection with, the services provided under this Tariff, any circuit, apparatus, system or method provided by the customer.
- (B) The customer shall defend, indemnify and save harmless the Telephone Company from and against suits, claims, and demands by third persons arising out of the construction, installation, operation, maintenance, or removal of the customer's circuits, facilities, or equipment connected to the Telephone Company's services provided under this Tariff, including, without limitation, Workmen's Compensation claims, actions for infringement of copyright and/or unauthorized use of program material, libel and slander actions based on the content of communications transmitted over the customer's circuits, facilities or equipment, and proceedings to recover taxes, fines, or penalties for failure of the customer to obtain or maintain in effect any necessary certificates, permits, licenses, or other authority to acquire or operate the services provided under this Tariff; provided, however, the foregoing indemnification shall not apply to suits, claims, and demands to recover damages for damage to property, death, or personal injury unless such suits, claims or demands are based on the tortuous conduct of the customer, its officers, agents or employees.
- (C) The customer shall defend, indemnify and save harmless the Telephone Company from and against any suits, claims, losses or damages, including punitive damages, attorney fees and court costs by the customer or third parties arising out of any act or omission of the customer in the course of using services provided under this Tariff.

2.3.9 Coordination with Respect to Network Contingencies

The customer shall, in cooperation with the Telephone Company, coordinate in planning the actions to be taken to maintain maximum network capability following natural or man-made disasters which affect telecommunications services.

ACCESS SERVICE

SECTION 2. GENERAL REGULATIONS (Cont.)

2.3 Obligations of the Customer (Cont.)

2.3.10 Jurisdictional Report Requirements

(A) Jurisdictional Reports

- (1) a) When a customer orders Feature Group A and/or Feature Group B Switched Access Service, the customer shall, in its order, state the projected percentage of interstate usage by end office for each Feature Group A and/or Feature Group B Switched Access Service group ordered. If the customer discontinues some, but not all, of the Feature Group A and/or Feature Group B Switched Access Services in a group, it shall provide the projected interstate percentage for such services which are discontinued.
 - b) Pursuant to Federal Communications Commission Order FCC 85-145 adopted April 16, 1985, interstate usage is to be developed as though every call that enters a customer network at a point within the same state as that in which the called station (as designated by the called station telephone number) is situated is an intrastate communication and every call for which the point of entry is in a state other than that where the called station (as designated by the called station telephone number) is situated is an interstate communication.
 - c) The projected interstate percentages will be used by the Telephone Company to apportion the usage between interstate and intrastate until a revised report is received as set forth in (6) following.
- (2) All single-line Feature Group A and B Switched Access Service usage and charges will be apportioned by the Telephone Company between interstate and intrastate. The projected interstate percentage reported as set forth in 1(a) and 1(b) preceding will be used to make such apportionment.

ACCESS SERVICE TARIFF

SECTION 2. GENERAL REGULATIONS (Cont.)

2.3 Obligations of the Customer (Cont.)

2.3.10 Jurisdictional Report Requirements (Cont.)

(A) Jurisdictional Reports (Cont.)

- (3) For multi-line hunt group or trunk group arrangements where either the interstate or the intrastate charges are based on measured usage, the interstate Feature Group A and/or Feature Group B, Switched Access Service(s) information reported as set forth in (1) preceding will be used to determine the charges as follows:

For all groups the number of access minutes for a group will be multiplied by the projected interstate percentage to develop the interstate access minutes. The number of access minutes for the group minus the developed interstate access minutes for the group will be the developed intrastate access minutes.

- (4) When a customer orders Feature Group D Switched Access Service(s), or if the jurisdiction cannot be determined from the call detail and the customer cannot provide the projected percentage of interstate usage for each end office group in its order, the Telephone Company will determine the projected interstate percentage as follows. For originating access minutes, the projected interstate percentage will be developed on a monthly basis by end office when the Feature Group D Switched Access Service access minutes are measured by dividing the measured interstate originating access minutes (the access minutes where the calling number is in one state and the called number is in another state) by the total originating access minutes when the call detail is adequate to determine the appropriate jurisdiction. For terminating access minutes, the data used by the Telephone Company to develop the projected interstate percentage for originating access minutes will be used to develop projected interstate percentage for such terminating access minutes. When originating call details are insufficient to determine the jurisdiction for the call, the customer shall supply the projected interstate percentage or authorize the Telephone Company to use the Telephone Company developed percentage. The Telephone Company will designate the number obtained by subtracting the projected interstate percentage for originating and terminating access minutes calculated by the Telephone Company from 100 (100 - Telephone Company calculated projected interstate percentage = intrastate percentage) as the projected intrastate percentage of use.

ACCESS SERVICE TARIFF

SECTION 2. GENERAL REGULATIONS (Cont.)

2.3 Obligations of the Customer (Cont.)

2.3.10 Jurisdictional Report Requirements (Cont.)

(A) Jurisdictional Reports (Cont.)

- (5) Except where Telephone Company measured access minutes are used as set forth in (4) preceding, the customer reported number of interstate services or interstate percentage of use as set forth in (1) or (4) preceding will be used until the customer reports a different projected interstate percentage for an in service end office group. When the customer adds BHMC lines or trunks to an existing end office group, the customer shall furnish a projected interstate percentage that applies to the added BHMC, lines or trunks. When the customer discontinues BHMC, lines or trunks from an existing group, the customer shall furnish a projected interstate percentage for the discontinued BHMC, lines or trunks in the end office group. The revised report will serve as the basis for future billing and will be effective on the next bill date. No prorating or back billing will be done based on the report.
- (6) Effective on the first of January, April, July and October of each year the customer shall update the interstate jurisdictional report. The customer shall forward to the Telephone Company, to be received no later than 15 days after the first of each such month, a revised report showing the interstate and intrastate percentage of use for the past three months ending the last day of December, March, June and September, respectively, for each service arranged for interstate use. Additionally, where the customer utilizes FGA Switched Access Service for calls between a Primary Exchange Carrier and a Secondary Exchange Carrier within the same Extended Area Service calling area, and/or Feature Group B Switched Access Service for calls between a Primary Exchange Carrier's access tandem and a subtending Secondary Exchange Carrier, where the Primary and Secondary Exchange Carriers are not the same Telephone Company and do not provide service under the same access service tariff and where the Primary and Secondary Exchange Carriers do not have a revenue sharing billing arrangement for subtending end offices of an access tandem, a copy of the revised report by end office will be provided by the customer to each billing Secondary Exchange Carrier identified in the Primary Exchange Carrier's tariff. The revised report will serve as the basis for the next three months billing and will be effective on the bill date for that service.

ACCESS SERVICE TARIFF

SECTION 2. GENERAL REGULATIONS (Cont.)

2.3 Obligations of the Customer (Cont.)

2.3.10 Jurisdictional Report Requirements (Cont.)

(A) Jurisdictional Reports (Cont.)

If the customer does not supply the reports, the Telephone Company will assume the percentages to be the same as those provided in the last quarterly report. For those cases in which a quarterly report has never been received from the customer, the Telephone Company will assume the percentages to be the same as those provided in the order for service as set forth in (1) preceding.

(7) When mixed interstate and intrastate Special Access Service is provided, the customer will include with the access order to the Company an estimate of whether the interstate traffic will comprise more than 10%, or less than 10% of total traffic.

- If the customer's estimate of the interstate traffic on the service involved constitutes 10% or less of the total traffic on that service, the service will be provided in accordance with the applicable rules and regulations of the appropriate intrastate tariff.

- If the customer's estimate of the interstate traffic on the service involved constitutes more than 10% of the total traffic on that service, the service will be provided in accordance with the applicable rules and regulations of this Tariff.

(B) If a billing dispute arises concerning the projected interstate percentage, the Telephone Company will ask the customer to provide the data the customer uses to determine the projected interstate percentage. The Telephone Company will not request such data more than once a year except in extreme circumstances. An audit of the records will be conducted by an independent auditor if the Telephone Company and the customer or the customer alone is willing to pay the expense. The customer shall supply the data within 30 days of the Telephone Company request.

ACCESS SERVICE TARIFF

SECTION 2. GENERAL REGULATIONS (Cont.)

2.3 Obligations of the Customer (Cont.)

2.3.10 Jurisdictional Report Requirements (Cont.)

(C) Identification and Rating of VoIP – PSTN Traffic

(1) Scope

VoIP-PSTN Traffic is defined as traffic exchanged between the Telephone Company end user and the customer in time division multiplexing (“TDM”) format that originates and/or terminates in Internet protocol (“IP”) format. This section governs the identification of VoIP-PSTN Traffic that is required to be compensated at interstate access rates as described in Section 6.1 of this Tariff. Specifically, this section establishes the method of separating such traffic (referred to in this tariff as “Relevant VoIP-PSTN Traffic”) from the customer’s traditional intrastate access traffic, so that such Relevant VoIP-PSTN Traffic can be billed in accordance with the FCC Order.

(2) Rating of VoIP-PSTN Traffic

The Relevant VoIP-PSTN Traffic identified in accordance with this tariff section will be billed at rates equal to the Telephone Company’s applicable tariffed interstate switched access rates as specified in Section 10 of this Tariff following#.

(3) Calculation and Application of Percent-VoIP-Usage Factor

- (a) The Telephone Company will determine the number of VoIP-PSTN Traffic minutes of use (MOU) to which interstate rates will be applied under (2), preceding, by applying an originating Percent VoIP Usage (PVU) factor to the total intrastate access MOU originated# by a Telephone Company end user and delivered to the customer and by applying a terminating PVU factor to the total intrastate access MOU terminated by a customer to the Telephone Company’s end user.

#Per FCC Second Order on Reconsideration as noted in Section 6.1, intrastate access rates will apply to originating interstate VoIP traffic from July 13, 2012 to June 30, 2014.

ACCESS SERVICE TARIFF

SECTION 2. GENERAL REGULATIONS (Cont.)

2.3 Obligations of the Customer (Cont.)

2.3.10 Jurisdictional Report Requirements (Cont.)

(C) Identification and Rating of VoIP – PSTN Traffic (Cont'd)

(3) Calculation and Application of Percent-VoIP-Usage Factor (Cont'd)

- (b) The customer will calculate and furnish to the Telephone Company an originating# PVU-C factor representing the whole number percentage of the customer's total originating intrastate access MOU that the customer receives from the Telephone Company and that is terminated in IP format and that would be billed by the Telephone Company as intrastate originating access MOU.
- (c) The customer will calculate and furnish to the Telephone Company a terminating PVU-C factor representing the whole number percentage of the customer's total terminating intrastate access MOU that the customer sent to Telephone Company and which originated in IP format and that would be billed by the Telephone Company as intrastate terminating access MOU.
- (d) The customer shall not modify their reported PIU factor to account for VoIP - PSTN Traffic.
- (e) The Telephone Company will calculate two factors (the "PVU-TC terminating factor" and "PVU-TC originating# factor") representing the percentage of the Telephone Company's total intrastate switched access MOU that the Telephone Company terminates and originates, respectively on its network in IP format. These factors, if greater than 0%, will be posted on the Telephone Company's web site.
- (f) The Telephone Company will use the PVU-C and PVU-TC factors to calculate two PVU factors that represent the percentage of total intrastate access MOU exchanged in TDM format (directly or indirectly) between the Telephone Company and the customer that originate# or terminate in IP format, whether at the Telephone Company's end, at the customer's end, or at both ends.

#Per FCC Second Order on Reconsideration as noted in Section 6.1, intrastate access rates will apply to originating interstate VoIP traffic from July 13, 2012 to June 30, 2014.

ACCESS SERVICE TARIFF

SECTION 2. GENERAL REGULATIONS (Cont.)

2.3 Obligations of the Customer (Cont.)

2.3.10 Jurisdictional Report Requirements (Cont.)

(C) Identification and Rating of VoIP – PSTN Traffic (Cont'd)

(3) Calculation and Application of Percent-VoIP-Usage Factor (Cont'd)

(f) (Cont.)

- (i) The PVU terminating factor will represent the percentage of total intrastate access MOU delivered by the Customer to the Telephone Company (whether directly or indirectly) in TDM format that terminates in IP format on the network of the Telephone Company. The PVU termination factor will be calculated as the sum of: (A) the terminating PVU-C factor and (B) the PVU-TC terminating factor times (1.0 minus the terminating PVU-C factor).
- (ii) The PVU originating# factor will represent the percentage of total intrastate access MOU delivered by the Telephone Company to the Customer (whether directly or indirectly) in TDM format that originates in IP format on the network of the Telephone Company. The PVU originating factor will be calculated as the sum of: (A) the originating PVU-C factor and (B) the PVU-TC originating factor times (1.0 minus the originating PVU-C factor).
- (g) The Telephone Company will apply the PVU terminating factor to the total intrastate access MOU delivered by the Customer to the Telephone Company (whether directly or indirectly) in TDM format for termination on the network of the Telephone Company (“Terminating Intrastate Access MOU”). The Telephone Company will apply the PVU originating factor to the total intrastate access MOU delivered by the Telephone Company to Customer (whether directly or indirectly) in TDM format that originated on the network of the Telephone Company (“Originating Intrastate Access MOU”).

#Per FCC Second Order on Reconsideration as noted in Section 6.1, intrastate access rates will apply to originating interstate VoIP traffic from July 13, 2012 to June 30, 2014.

ACCESS SERVICE TARIFF

SECTION 2. GENERAL REGULATIONS (Cont.)

2.3 Obligations of the Customer (Cont.)

2.3.10 Jurisdictional Report Requirements (Cont.)

(C) Identification and Rating of VoIP – PSTN Traffic (Cont'd)

(3) Calculation and Application of Percent-VoIP-Usage Factor (Cont'd)

(g) (Cont.)

Example 1: The PVU-TC terminating factor is 0% and the terminating PVU-C factor is 40%. The PVU terminating factor is equal to $40\% + (0\% \times 60\%) = 40\%$. The Telephone Company will treat 40% of the Customer's terminating Intrastate access MOU as VoIP-PSTN traffic and bill 40% of the Customer's terminating Intrastate access MOU at charges equal to its applicable tariffed interstate switched access rates#.

Example 2: The PVU-TC originating factor is 0% and the originating PVU-C factor is 40%. The PVU originating factor is $40\% + (0\% \times 60\%) = 40\%$. The Telephone Company will treat 40% of the Customer's originating Intrastate Access MOU as VoIP-PSTN traffic and bill 40% of Customer's originating Intrastate access MOU at charges equal to its applicable tariffed interstate switched access rates#.

- (h) Both the customer provided originating# and terminating PVU-C factors and the Telephone Company provided PVU-TC terminating and originating factors shall be based on information such as the number of the customer's retail VoIP subscriptions in the state (e.g. as reported on F.C.C. Form 477), traffic studies, actual call detail or other relevant and verifiable information which will be provided to the Telephone Company upon request.
- (i) The customer shall retain the call detail, work papers, and information used to develop the PVU-C factors for a minimum of one year.
- (j) If the customer does not furnish the Telephone Company with PVU-C factors, the Telephone Company will utilize PVU-C factors equal to zero.

#Per FCC Second Order on Reconsideration as noted in Section 6.1, intrastate access rates will apply to originating interstate VoIP traffic from July 13, 2012 to June 30, 2014.

ACCESS SERVICE TARIFF

SECTION 2. GENERAL REGULATIONS (Cont.)

2.3 Obligations of the Customer (Cont.)

2.3.10 Jurisdictional Report Requirements (Cont.)

(C) Identification and Rating of VoIP – PSTN Traffic (Cont'd)

(4) Initial PVU-C Factors

- (a) If the PVU-C factors are provided by the customer by October 15, 2012, once the factor is available the Telephone Company will adjust the customer's bills to reflect the PVU-C factors retroactively to July 1, 2012. If the customer does not provide PVU-C factors by October 15, 2012 the Telephone Company will set the PVU-C factors equal to zero, as specified in subsection (C)(3)(j), above.
- (b) If the PVU factors cannot be implemented in the Telephone Company's system by July 1, 2012, once the factors can be implemented the Telephone company will adjust the customer's bill retroactively to reflect the PVU-C factors as described in (C) (4)(a) above and (5) below.
- (c) The Telephone Company may choose to provide credits based on the reported PVU factors on a Quarterly basis until such time as billing system modifications can be implemented.

(5) PVU-C Factor Updates

The customer may update the PVU-C factors quarterly using the method set forth in subsection (3)(b) & (3) (c), above. If the customer chooses to submit such updates, it shall forward to the Telephone Company, no later than 15 days after the first day of January, April, July and/or October of each year, revised PVU-C factors based on data for the prior three months, ending the last day of December, March, June and September, respectively. The revised PVU-C factors will serve as the basis for future billing and will be effective on the bill date of each such month and shall serve as the basis for subsequent monthly billing until superseded by new PVU-C factors. No prorating or back billing will be done based on the updated PVU-C factors.

ACCESS SERVICE TARIFF

SECTION 2. GENERAL REGULATIONS (Cont.)

2.3 Obligations of the Customer (Cont.)

2.3.10 Jurisdictional Report Requirements (Cont.)

(C) Identification and Rating of VoIP – PSTN Traffic (Cont'd)

(6) PVU-C Factor Verification

(a) Not more than four times in any year, the Telephone Company may request from the customer an overview of the process used to determine the PVU-C factors, the call detail records, description of the method for determining how the end user originates and terminates calls in IP format, and other information used to determine the customer's PVU-C factors furnished to the Company in order to validate the PVU-C factors supplied. The customer shall comply, and shall reasonably supply the requested data and information within 15 days of the Telephone Company's request.

(b) The Telephone Company may dispute the customer's PVU-C factors based upon:

A review of the requested data and information provided by the customer,

The Telephone Company's reasonable review of other market information, F.C.C. reports on VoIP lines, such as F.C.C. Form 477 or state level results based on the F.C.C. Local Competition Report or other relevant data.

A change in the reported PVU-C factors by more than five percentage points from the preceding quarter.

(c) If after review of the data and information, the customer and the Telephone Company establish revised PVU-C factors, the Telephone Company will begin using those revised PVU-C factors with the next bill period

ACCESS SERVICE TARIFF

SECTION 2. GENERAL REGULATIONS (Cont.)

2.3 Obligations of the Customer (Cont.)

2.3.10 Jurisdictional Report Requirements (Cont.)

(C) Identification and Rating of VoIP – PSTN Traffic (Cont'd)

(6) PVU-C Factor Verification

(d) If the dispute is unresolved, the Telephone Company may initiate an audit. The Company shall limit audits of the customer's PVU-C factors to no more than twice per year. The customer may request that the audit be conducted by an independent auditor. In such cases the associated auditing expenses will be paid by the customer.

- In the event that the customer fails to provide adequate records to enable the Company or an independent auditor to conduct an audit verifying the customer's PVU-C factors, the Company will bill the usage for all contested periods using the most recent undisputed PVU-C factors reported by the customer. These PVU-C factors will remain in effect until the audit can be completed.
- During the audit, the most recent undisputed PVU-C factors from the previous reporting period will be used by the Company.
- The Company will adjust the customer's PVU-C factors based on the results of the audit and implement the revised PVU-C factors in the next billing period or quarterly report date, whichever is first. The revised PVU-C factors will apply for the next two quarters before new factors can be submitted by the customer.
- If the audit supports the customer's PVU-C factors, the usage for the contested periods will be adjusted to reflect the customer's audited PVU-C factors.

ACCESS SERVICE TARIFF

SECTION 2. GENERAL REGULATIONS (Cont.)

2.3 Obligations of the Customer (Cont.)

2.3.11 Determination of Interstate Charges for Mixed Interstate and Intrastate Switched Access Service

When mixed interstate and intrastate Switched Access Service is provided, all charges (i.e., nonrecurring, monthly, and/or usage), including optional features charges, will be prorated between interstate and intrastate. The percentage provided in the reports as set forth in 2.3.10(A) preceding will serve as the basis for prorating the charges. The percentage of a Switched Access Service to be charged as interstate is applied in the following manner:

- (A) For monthly and nonrecurring chargeable rate elements, multiply the percent interstate use times the quantity of chargeable elements times the stated tariff rate per element.
- (B) For usage sensitive (i.e., access minutes and calls) chargeable rate elements, multiply the percent interstate use times actual use (i.e., measured or Telephone Company assumed average use) times the stated tariff rate.

The interstate percentage will change as revised usage reports are submitted as set forth in 2.3.10 preceding.

2.4 Payment Arrangements and Credit Allowances

2.4.1 Payment of Rates and Charges and Deposits

- (A) The Telephone Company will, in order to safeguard its interests, require a customer which has a proven history of late payments to the Telephone Company or does not have established credit to make a deposit prior to or at any time after the provision of a service to the customer to be held by the Telephone Company as a guarantee of the payment of rates and charges. No such deposit will be required of a customer which is a successor of a company which has established credit and has no history of late payments to the Telephone Company. Such deposit may not exceed the actual or estimated rates and charges for the service for a two-month period. The fact that a deposit has been made in no way relieves the customer from complying with the Telephone Company's regulations as to the prompt payment of bills. At such time as the provision of the service to the customer is terminated, the amount of the deposit will be credited to the customer's account and any credit balance which may remain will be refunded. Such a deposit will be refunded or credited to the account when the customer has established credit or after the customer has established a one-year prompt payment record at any time prior to the termination of the provision of the service to the customer.

ACCESS SERVICE TARIFF

SECTION 2. GENERAL REGULATIONS (Cont.)

2.4 Payment Arrangements and Credit Allowances (Cont.)

2.4.1 Payment of Rates and Charges and Deposits (Cont.)

In case of a cash deposit, for the period the deposit is held by the Telephone Company, the customer will receive interest at the same percentage rate as that set forth in 2.4.1(B)(4)(b)(I) or in 2.4.1(B)(4)(b)(II), whichever is lower. The rate will be compounded daily for the number of days from the date the customer deposit is received by the Telephone Company to and including the date such deposit is credited to the customer's account or the date the deposit is refunded by the Telephone Company. Should a deposit be credited to the customer's account, as indicated above, no interest will accrue on the deposit from the date such deposit is credited to the customer's account.

(B) The Telephone Company shall bill on a current basis all charges incurred by and credits due to the customer under this Tariff attributable to services established or discontinued during the preceding billing period. In addition, the Telephone Company shall bill in advance charges for all services to be provided during the ensuing billing period except for charges associated with service usage and for the Federal Government which will be billed in arrears. The bill day (i.e., the billing date of a bill for a customer for Access Service under this Tariff), the period of service each bill covers and the payment date will be as follows:

(1) For End User Access Service and Presubscription Service, the Telephone Company will establish a bill day each month for each end user account. The bill will cover End User Access Service charges for the ensuing billing period except for End User Access Service for the Federal Government which will be billed in arrears. Any known unbilled charges for prior periods and any known unbilled adjustments for prior periods for End User Access Service and Presubscription Service will be applied to this bill. Such bills are due when rendered.

ACCESS SERVICE TARIFF

SECTION 2. GENERAL REGULATIONS (Cont.)

2.4 Payment Arrangements and Credit Allowances (Cont.)

2.4.1 Payment of Rates and Charges and Deposits (Cont.)

- (2) For Service other than End User Access Service and Presubscription Service, the Telephone Company will establish a bill day each month for each customer account. The bill will cover non-usage sensitive service charges for the ensuing billing period for which the bill is rendered and any known unbilled non-usage sensitive charges for prior periods and unbilled usage charges for the period after the last bill day through the current bill day. Any known unbilled usage charges for prior periods and any known unbilled adjustments will be applied to this bill. Payment for such bills is due as set forth in (3) following. If payment is not received by the payment date, as set forth in (3) following in immediately available funds, a late payment penalty will apply as set forth in (3) following.
- (3) (a) All bills dated as set forth in (2) preceding for service, other than End User Service and Presubscription Service, provided to the customer by the Telephone Company are due 31 days (payment date) after the bill day or by the next bill date (i.e., same date in the following month as the bill date), whichever is the shorter interval, except as provided herein, and are payable in immediately available funds. If such payment date would cause payment to be due on a Saturday, Sunday or Holiday (i.e., New Year's Day, Independence Day, Labor Day, Thanksgiving Day, Christmas Day, the second Tuesday in November and a day when Washington's Birthday, Memorial Day or Columbus Day is legally observed), payment for such bills will be due from the customer as follows:

If such payment date falls on a Sunday or on a Holiday which is observed on a Monday, the payment date shall be the first Non-Holiday day following such following such Sunday or Holiday. If such payment date falls on a Saturday or on a Holiday which is observed on Tuesday, Wednesday, Thursday or Friday, the payment date shall be the last Non-Holiday day preceding such Saturday or Holiday.

ACCESS SERVICE TARIFF

SECTION 2. GENERAL REGULATIONS (Cont.)

2.4 Payment Arrangements and Credit Allowances (Cont.)

2.4.1 Payment of Rates Charges and Deposits (Cont.)

- (3) (b) Further, if any portion of the payment is received by the Telephone Company after the payment date as set forth in (a) preceding, or if any portion of the payment is received by the Telephone Company in funds which are not immediately available to the Telephone Company, then a late payment penalty shall be due to the Telephone Company. The late payment penalty shall be the portion of the payment not received by the payment date times a late factor. The late factor shall be the lesser of:
- (I) the highest interest rate (in decimal value) which may be levied by law for commercial transactions, compounded daily for the number of days from the payment date to and including the date that the IC actually makes the payment to the Telephone Company, or
 - (II) 0.000292 per day, compounded daily for the number of days from the payment date to and including the date that the customer actually makes the payment to the Telephone Company.
- (c) In the event that a billing dispute concerning any charges billed to the customer by the Telephone Company is resolved in favor of the Telephone Company, any payments withheld pending settlement of the dispute shall be subject to the late payment penalty set forth in (b) preceding. If the customer disputes the bill on or before the payment date, any late payment charge for the disputed amount will not start until 10 days after the payment date. If the billing dispute is resolved in favor of the customer, no late payment penalty will apply to the disputed amount.

ACCESS SERVICE TARIFF

SECTION 2. GENERAL REGULATIONS (Cont.)

2.4 Payment Arrangements and Credit Allowances (Cont.)

2.4.1 Payment of Rates, Charges and Deposits (Cont.)

In addition, if the customer disputes the billed amount and pays the total amount (i.e., the non-disputed amount and the disputed amount) on or before the payment date and the billing dispute is resolved in the favor of the customer, the customer will receive a credit for a disputed amount penalty from the Telephone Company if the billing dispute is not resolved within 10 working days following the payment date or the date the customer furnishes to the Telephone Company documentation to support its claim plus 10 working days, whichever date is the later date. The disputed amount penalty shall be the disputed amount resolved in the customer's favor times a penalty factor. The penalty factor is as set forth in 2.4.1(B)(3)(b) preceding.

- (d) In the event of a billing dispute, it is the responsibility of the Telephone Company to make any reasonably available information necessary to verify a bill.
- (C) Adjustments for the quantities of services established or discontinued in any billing period beyond the minimum period set forth for services in other sections of this Tariff will be prorated to the number of days or major fraction of days based on a 30-day month. The Telephone Company will, upon request and if available, furnish such detailed information as may reasonably be required for verification of any bill.
- (D) When a rate as set forth in this Tariff is shown to more than two decimal places, the charges will be determined using the rate shown. The resulting amount will then be rounded to the nearest penny (i.e., rounded to two decimal places).

2.4.2 Minimum Periods

The minimum period for which services are provided and rates and charges are applicable is one month except as otherwise noted in the applicable sections of this Tariff.

ACCESS SERVICE TARIFF

SECTION 2. GENERAL REGULATIONS (Cont.)

2.4 Payment Arrangements and Credit Allowances (Cont.)

2.4.2 Minimum Periods (Cont.)

When a service is discontinued prior to the expiration of the minimum period, charges are applicable, whether the service is used or not, as follows:

- (A) When a service with a one-month minimum period is discontinued prior to the expiration of the minimum period, a one-month charge will apply at the rate level in effect at the time service is discontinued.
- (B) When a service with a minimum period greater than one month is discontinued prior to the expiration of the minimum period, the applicable charge will be the total monthly charges, at the rate level in effect at the time service is discontinued, for the remainder of the minimum period.
- (C) When a customer requests that a service be discontinued after the minimum period has lapsed, the Telephone Company will discontinue billing for services on the day the customer's request for disconnection is received or on the date specified by the customer, whichever is later. The request for disconnection may be made verbally, but any verbal notice must be confirmed in writing within 10 days.

2.4.3 Credit Allowance for Service Interruptions

(A) General

A service is interrupted when it becomes unusable to the customer because of a failure of a facility component used to furnish service under this Tariff or in the event that the protective controls applied by the Telephone Company Result in a complete loss of service by the customer as set forth in 6.4.1 following. An interruption period starts when an inoperative service is reported to the Telephone Company, and ends when the service is operative.

(B) When a Credit Allowance Applies

In case of an interruption to any service, allowance for the period of interruption, if not due to the negligence of the customer, shall be as follows:

- (1) For Switched Access Service, no credit shall be allowed for an interruption of less than 24 hours. The customer shall be credited for an interruption of 24 hours or more at the rate of 1/720 of the sum of the applicable monthly rate elements for each hour that the interruption continues. Any fraction of an hour will be rounded to the nearest hour. That is, any fraction of an hour greater than 30 minutes but less than one full hour will be rounded up to the nearest full hour. Likewise, a fractional hour less than or equal to 30 minutes will be rounded down.

ACCESS SERVICE TARIFF

SECTION 2. GENERAL REGULATIONS (Cont.)

2.4 Payment Arrangements and Credit Allowances (Cont.)

2.4.3 Credit Allowance for Service Interruptions (Cont.)

(B) When a Credit Allowance Applies (Cont.)

- (2) For Special Access Service, no credit shall be allowed for an interruption of less than 30 minutes. The customer shall be credited for an interruption of 30 minutes or more at the rate of 1/1440 of the sum of the applicable monthly rate elements for each period of 30 minutes that the interruption continues. Any fraction thereof will be rounded to the nearest 30-minute period. That is any fraction of a 30-minute period greater than 15 minutes but less than 30 minutes will be rounded up to the nearest 30-minute period. Likewise, a period less than or equal to 15 minutes will be rounded down.
- (3) The credit allowance(s) for an interruption or for a series of interruptions shall not exceed the monthly rate for the service interrupted in any one monthly billing period.

(C) When a Credit Allowance Does Not Apply

No credit allowance will be made for:

- (1) Interruptions caused by the negligence of the customer.
- (2) Interruptions of a service due to the failure of equipment or systems provided by the customer or others.
- (3) Interruptions of a service during any period in which the Telephone Company is not afforded access to the premises where the service is terminated.
- (4) Interruptions of a service when the customer has released that service to the Telephone Company for maintenance purposes, to make rearrangements, or for the implementation of an order for a change in the service during the time that was negotiated with the customer prior to the release of that service. Thereafter, a credit allowance as set forth in (B) preceding applies.

ACCESS SERVICE TARIFF

SECTION 2. GENERAL REGULATIONS (Cont.)

2.4 Payment Arrangements and Credit Allowances (Cont.)

2.4.3 Credit Allowance for Service Interruptions (Cont.)

(C) When a Credit Allowance Does Not Apply (Cont.)

(5) (Reserved for Future Use)

(6) Periods when the customer elects not to release the service for testing and/or repair and continues to use it on an impaired basis.

(7) An interruption or a group of interruptions, resulting from a common cause, for amounts less than one dollar.

(D) Use of an Alternative Service Provided by the Telephone Company

Should the customer elect to use an alternative service provided by the Telephone Company during the period that a service is interrupted, the customer must pay the tariffed rates and charges for the alternative service used.

(E) Temporary Surrender of a Service

In certain instances, the customer may be requested to surrender a service for purposes other than maintenance, testing or activity relating to a service order. If the customer consents, a credit allowance will be granted. The credit allowance will be 1/1440 of the monthly rate for each period of 30 minutes or major fraction thereof that the service is surrendered. In no case will the credit allowance exceed the monthly rate for the service surrendered in any one monthly billing period.

ACCESS SERVICE TARIFF

SECTION 2. GENERAL REGULATIONS (Cont.)

2.4 Payment Arrangements and Credit Allowances (Cont.)

2.4.4 Re-establishment of Service Following Fire, Flood or Other Occurrence

(A) Non-recurring Charges Do Not Apply

Charges do not apply for the re-establishment of service following a fire, flood or other occurrence attributed to an Act of God provided that:

- (1) The service is of the same type as was provided prior to the fire, flood or other occurrence.
- (2) The service is for the same customer.
- (3) The service is at the same location on the same premises.
- (4) The re-establishment of service begins within 60 days after Telephone Company service is available. (The 60-day period may be extended a reasonable period if the renovation of the original location on the premises affected is not practical within the allocated time period.)

(B) Non-recurring Charges Apply

Non-recurring charges apply for establishing service at a different location on the same premises or at a different premises pending re-establishment of service at the original location.

2.4.5 Title or Ownership Rights

The payment of rates and charges by customers for the services offered under the provisions of this Tariff does not assign, confer or transfer title or ownership rights to proposals or facilities developed or utilized, respectively, by the Telephone Company in the provision of such services.

ACCESS SERVICE TARIFF

SECTION 2. GENERAL REGULATIONS (Cont.)

2.4 Payment Arrangements and Credit Allowances (Cont.)

2.4.6 Ordering, Rating and Billing of Access Services Where More Than One Exchange Telephone Company Is Involved

- (A) When Feature Group A, B, or D Switched Access Service or Special Access Service is ordered by a customer where one end of the Transport or Channel Mileage element is in one Exchange Telephone Company operating territory and the other end is in another Exchange Telephone Company operating territory, the ordering procedures described in Section 5.2.7 will apply. The ordering, rating, and billing procedures discussed in both Sections 2.4.6 and 5.2.7 are in accordance with industry standards specified in the Multiple Exchange Carrier Access Billing guidelines (MECAB) and Multiple Exchange Carrier Ordering and Design guidelines (MECOD) technical publications. Each Exchange Telephone Company will provide its portion of the Transport or Channel Mileage element in its operating territory to an interconnection point with another Exchange Telephone Company. Each exchange carrier will prepare its own bill separately for the interexchange carrier as discussed in Section 5.2.7.

Where the premises of the ordering customer and at least one other customer premises involved in the order is in a different operating territory, the mileage used to determine the Transport or Channel Mileage element will be the mileage measured from the Telephone Company premises for one end of the Transport or Channel Mileage element in the Exchange Telephone Company operating territory to the Telephone Company premises for the other end of the Transport or Channel Mileage element in the other Exchange Telephone Company operating territory. The rate for the Transport or Channel Mileage element will be the rate in each Exchange Telephone Company's tariff for the mileage measured as set forth in the preceding sentence. Each Exchange Telephone Company's charge for the Transport or Channel Mileage element will be the product of: [the Exchange Telephone Company's rate for the mileage measured between the two Telephone Company premises for the two ends of the Transport or Channel Mileage element] and [ratio of the mileage from the Exchange Telephone Company's premises to the interconnection point, divided by the sum of the mileage from the rating Exchange Telephone Company premises to the interconnection point and the mileage from the other involved Exchange Telephone Company premises to the interconnection point(s).[#] All other appropriate charges in each Exchange Telephone Company's tariff are applicable.

[#] If a billing interstate percentage is filed for the specific route involved in Exchange Carrier Association Tariff F.C.C No. 4., it will be applied rather than the [ratio of the mileage from the Exchange Telephone Company's premises to the interconnection point, divided by the sum of the mileage from the rating Exchange Telephone Company premises to the interconnection point and the mileage from the other involved Exchange Telephone Company premises to the interconnection point(s)]

ACCESS SERVICE TARIFF

SECTION 2. GENERAL REGULATIONS (Cont.)

2.4 Payment Arrangements and Credit Allowances (Cont.)

2.4.6 Ordering, Rating and Billing of Access Services Where More Than One Exchange Telephone Company Is Involved (Cont.)

The interconnection point will be determined by the Exchange Telephone Companies involved and will be listed in National Exchange Carrier Association Tariff F.C.C. No. 4.

(B) Where the customer utilizes the FGA Switched Access Service for calls between a Primary Exchange Carrier and a Secondary Exchange Carrier within the same Extended Area Service calling area, and/or Feature Group B Switched Access Service for calls between a Primary Exchange Carrier's access tandem and a subtending Secondary Exchange Carrier, the Secondary Exchange Carrier will also apply Switched Access Service End Office rates provided the following criteria are met:

- the Primary and Secondary Exchange Carriers are not the same Telephone Company,
- the Primary and Secondary Exchange Carriers do not provide service under the same access tariff,
- the Primary and Secondary Exchange Carriers do not have a revenue sharing arrangement where the Primary Exchange Carrier bills the total cost of access which includes the Secondary Exchange Carrier's cost of access.

2.4.7 Notice for Changes in Billing Procedures

The Telephone Company will provide 30 days' notice to all customers if any changes in the billing procedures described in 2.4.6 are made.

2.5 Connections

Equipment and Systems (i.e., terminal equipment, multi-line terminating systems and communications systems) may be connected with Switched and Special Access Service furnished by the Telephone Company where such connection is made in accordance with the provisions specified in 2.1 and 2.2 preceding.

ACCESS SERVICE TARIFF

SECTION 2. GENERAL REGULATIONS (Cont.)

2.6 Definitions

Certain terms used herein are defined as follows:

Access Minutes

The term "Access Minutes" denotes that usage of exchange facilities in intrastate service for the purpose of calculating chargeable usage. On the originating end of an intrastate call, usage is measured from the time the originating End User's call is delivered by the Telephone Company to and acknowledged as received by the customer's facilities connected with the originating exchange. On the terminating end of an intrastate call, usage is measured from the time the call is received by the End User in the terminating exchange. Timing of usage at both originating and terminating ends of an intrastate call shall terminate when the calling or called party disconnects, whichever event is recognized first in the originating and terminating end exchanges, as applicable.

Answer/Disconnect Supervision

The term "Answer/Disconnect Supervision" denotes the transmission of the switch trunk equipment supervisory signal (Off-Hook or On-Hook) to the customer's point of termination for terminating calls to the exchange as an indication that the called party has answered or disconnected.

Attenuation Distortion

The term "Attenuation Distortion" denotes the difference in loss at specified frequencies relative to the loss at 1004 Hz, unless otherwise specified.

Automatic Number Identification (ANI)

The term "Automatic Number Identification" denotes the Multi-Frequency (MF) signaling parameter that identifies the billing number of the calling party.

Business Day

The term "Business Day" denotes the times of day that a company is open for business. These are 8:00 a.m. to 5:00 p.m., with an hour for lunch, Monday through Friday, resulting in a standard forty (40) hour work week.

Busy Hour Minutes of Capacity (BHMC)

The term "Busy Hour Minutes of Capacity (BHMC)" denotes the customer specified maximum amount of Switched Access Service access minutes the customer expects to be handled in an end office switch during any hour in an 8:00 a.m. to 11:00 p.m. period for the Feature Group ordered. This customer furnished BHMC quantity is the input data the Telephone Company uses to determine the number of transmission paths for the Feature Group ordered.

ACCESS SERVICE TARIFF

SECTION 2. GENERAL REGULATIONS (Cont.)

2.6 Definitions (Cont.)

Call

The term "Call" denotes a customer attempt for which the complete address code (e.g., 0-, 911, or 10 digits) is provided to the serving dial tone office.

Calling Party Number (CPN)

The term "Calling Party Number" denotes the SS7 signaling parameter that identifies the subscriber line number or directory number of the calling party.

Carrier or Common Carrier

See Interexchange Carrier.

Central Office

The term "Central Office" denotes a local Telephone Company switching system where Telephone Exchange Service customer station loops are terminated for purposes of interconnection to each other and to trunks.

Central Office Prefix

The term "Central Office Prefix" denotes the first three digits (NXX) of the 7-digit telephone number assigned to a customer's Telephone Exchange Service when dialed on a local basis.

Channel(s)

The term "Channel(s)" denotes an electrical or photonic, in the case of fiber optic based transmission systems, communications path between two or more points of termination.

Channel Service Unit

The term "Channel Service Unit" denotes equipment which performs one or more of the following functions: termination of a digital facility, regeneration of digital signals, detection and/or correction of signal format error, and remote loop back.

Charge Number (CN)

The term "Charge Number" denotes the SS7 signaling parameter that identifies the billing telephone number of the calling party.

Coin Station

The term "Coin Station" denotes a location where Telephone Company equipment is provided in a public or semi-public place where Telephone Company customers can originate telephonic communications and pay the applicable charges by inserting coins into the equipment.

ACCESS SERVICE TARIFF

SECTION 2. GENERAL REGULATIONS (Cont.)

2.6 Definitions (Cont.)

Common Line

A common line-residence is a line or trunk provided under the resident regulations of the general and/or local exchange service tariffs terminated on a central office switch. A common line-business is a line provided under the business regulations of the general and/or local service tariffs.

Communications System

The term "Communications System" denotes facilities which are capable of communications between terminal equipment provided by other than the Telephone Company.

Customer(s)

The term "Customer(s)" denotes any individual, partnership, association, joint-stock company, trust, corporation, governmental entity or other entity which subscribes to the services offered under this Tariff, including but not limited to End Users, Interexchange Carriers (ICs) and other telecommunications carriers or providers originating or terminating Toll VoIP - PSTN Traffic.

Detail Billing

The term "Detail Billing" denotes the listing of each message and/or rate element for which charges to a customer are due on a bill prepared by the Telephone Company.

Directory Assistance

The term "Directory Assistance" denotes the provision of telephone numbers by an operator when the operator location is accessed by a customer by dialing (NPA) 555-1212.

Effective 4-Wire

The term "Effective 4-Wire" denotes a condition which permits the simultaneous independent transmission of information in both directions over a channel. The method of implementing effective 4-wire transmission is at the discretion of the Telephone Company (physical, time domain, frequency-domain separation or echo cancellation techniques). Effective 4-wire channel may be terminated with a 2-wire interface at the customer's premises. However, when terminated 2-wire, simultaneous independent transmission cannot be supported because the 2-wire interface combines the transmission paths into a single path.

ACCESS SERVICE TARIFF

SECTION 2. GENERAL REGULATIONS (Cont.)

2.6 Definitions (Cont.)

Effective 2-Wire

The term "Effective 2-Wire" denotes a condition which permits the simultaneous transmission in both directions over a facility, but it is not possible to ensure independent information transmission in both directions. Effective 2-wire facilities may be terminated with 2-wire or 4-wire interfaces.

End Office Switch

The term "End Office Switch" denotes a local Telephone Company switching system where Telephone Exchange Service customer station loops are terminated for purposes of interconnection to trunks. Included are Remote Switching modules and Remote Switching Systems served by a host office in a different wire center.

End User

The term "End User" denotes any customer of an interstate or foreign telecommunications service that is not a carrier except that a carrier other than a telephone company shall be deemed to be an "end user" when such carrier uses a telecommunications service for administrative purposes and a person or entity that offers telecommunications services exclusively as a reseller shall be deemed to be an "end user" if all resale transmissions offered by such reseller originate on the premises of such reseller.

Entrance Facility

The term "Entrance Facility" denotes a Switched Access Service dedicated Local Transport facility between the customer's serving wire center and the customer designated premises

Entry Switch

See First Point of Switching.

Envelope Delay Distortion (EDD)

The term "Envelope Delay Distortion" denotes a measure of the linearity of the phase versus frequency of a channel.

Exchange

The term "Exchange" denotes a unit, generally smaller than a local access and transport area, established by the Telephone Company for the administration of communications service in a specified area which usually embraces a city, town or village and its environs. It consists of one or more central offices together with the associated facilities used in furnishing communications service within that area. One or more designated exchanges comprise a given local access and transport area.

ACCESS SERVICE TARIFF

SECTION 2. GENERAL REGULATIONS (Cont.)

2.6 Definitions (Cont.)

First Point of Switching

The term "First Point of Switching" denotes the first Telephone Company location at which switching occurs on the terminating path of a call proceeding from a premises to the terminating end office and, at the same time, the last Telephone Company location at which switching occurs on the originating path of a call proceeding from the originating end office to a premises.

Grandfathered

The term "Grandfathered" denotes terminal equipment, multi-line terminating systems, and protective circuitry directly connected to the facilities utilized to provide services under the provisions of this Tariff, and which are considered grandfathered under Part 68 of the FCC's Rules and Regulations.

Host Office

The term "Host Office" denotes an electronic switching system which provides call processing capabilities for one or more Remote Switching Modules or Remote Switching Systems.

Immediately Available Funds

The term "Immediately Available Funds" denotes a corporate or personal check drawn on a bank account and funds which are available for use by the receiving party on the same day on which they are received and include U.S. Federal Reserve bank wire transfers, U.S. Federal Reserve notes (paper cash), U.S. coins, U.S. Postal Money Orders and New York Certificates of Deposit.

Interexchange Carrier or Interexchange Common Carrier

The terms "Interexchange Carrier" or "Interexchange Common Carrier" denote any individual, partnership, association, joint-stock company, trust, governmental entity or corporation engaged for hire in intrastate communication by wire or radio, between two or more exchanges.

Internet Protocol (IP) Signaling

The term "Internet Protocol (IP) Signaling" denotes a packet data-oriented protocol used for communicating call signaling information.

ACCESS SERVICE TARIFF

SECTION 2. GENERAL REGULATIONS (Cont.)

2.6 Definitions (Cont.)

Interstate Communications

The term "Interstate Communications" denotes both interstate and foreign communications.

Intrastate Communications

The term "Intrastate Communications" denotes any communications within a state subject to oversight by a state regulatory commission as provided by the laws of the state involved.

Line Side Connection

The term "Line Side Connection" denotes a connection of a transmission path to the line side of a local exchange switching system.

Local Access and Transport Area (LATA)

The term "Local Access and Transport Area" denotes a geographic area established for the provision and administration of communications service. It encompasses one or more designated exchanges, which are grouped to serve common social, economic and other purposes.

Message

See "Call."

Multi – Frequency Signaling (MF) Signaling

The term "Multi-Frequency (MF) Signaling" denotes an in-band signaling method in which call signaling information is transmitted between network switches using the same voiceband channel used for voice.

Network Control Signaling

The term "Network Control Signaling" denotes the transmission of signals used in the telecommunications system which perform functions such as supervision (control, status, and charge signals), address signaling (e.g., dialing), calling and called number identification, rate of flow, service selection error control and audible tone signals (call progress signals indicating re-order or busy conditions, alerting, coin denominations, coin collect and coin return tones) to control the operation of the telecommunications system.

North American Numbering Plan

The term "North American Numbering Plan" denotes a three-digit area or Numbering Plan Area (NPA) code and a seven-digit telephone number made up of a three-digit Central Office (CO) code plus a four-digit station number.

ACCESS SERVICE TARIFF

SECTION 2. GENERAL REGULATIONS (Cont.)

2.6 Definitions (Cont.)

Off-Hook

The term "Off-Hook" denotes the active condition of Switched Access or a Telephone Exchange Service line.

On-Hook

The term "On-Hook" denotes the idle condition of Switched Access or a Telephone Exchange Service Line.

Originating Direction

The term "Originating Direction" denotes the use of access service for the origination of calls from an End User Premises to a Customer's Premises.

Pay Telephone

The term "Pay Telephone" denotes Telephone Company provided instruments and related facilities that are available to the general public for public convenience and necessity, including public and semi-public coin and coinless telephones.

Point of Termination

The term "Point of Termination" denotes the point of demarcation within a customer-designated premises, at which the Telephone Company's responsibility for the provision of Access Service ends.

Premises

The term "Premises" denotes a building or buildings on continuous property (except railroad rights-of-way, etc.) not separated by a public highway.

Primary Exchange Carrier

The term "Primary Exchange Carrier" denotes the Local Exchange Telephone Company in whose exchange a customer's first point of switching (i.e., dial tone office for FGA, access tandem for FGB) is located.

Registered Equipment

The term "Registered Equipment" denotes the customer's premises equipment (CPE) which complies with and has been approved within the Registration Provisions of Part 68 of the FCC's Rules and Regulations.

ACCESS SERVICE TARIFF

SECTION 2. GENERAL REGULATIONS (Cont.)

2.6 Definitions (Cont.)

Remote Switching Modules and/or Remote Switching Systems

The term "Remote Switching Modules and/or Remote Switching Systems" denotes small, remotely controlled electronic end office switches which obtain their call processing capability from a Host Office. The Remote Switching Modules and/or Remote Switching Systems cannot accommodate direct trunks.

Secondary Exchange Carrier

The term "Secondary Exchange Carrier" denotes the Local Exchange Telephone Company in whose exchange a customer's end user's end office is located and where the customer's first point of switching is provided by a Primary Exchange Carrier who is not the same Exchange Carrier as the Secondary Exchange Carrier.

Shortage of Facilities of Equipment

The term "Shortage of Facilities or Equipment" denotes a condition which occurs when the Telephone Company does not have appropriate cable, switching capacity, bridging, or multiplexing equipment, etc., necessary to provide the Access Service requested by the customer.

Terminating Direction

The term "Terminating Direction" denotes the use of Access Service for the completion of calls from a Customer's Premises to an End User Premises.

Toll VoIP – PSTN Traffic

The term "Toll VoIP - PSTN Traffic" denotes a customer's interexchange voice traffic exchanged with the Telephone Company in Time Division Multiplexing format over PSTN facilities, which originates and/or terminates in Internet Protocol (IP) format. "Toll VoIP-PSTN Traffic" originates and/or terminates in IP format when it originates from and/or terminates to an end user customer of a service that requires IP-compatible customer premises equipment.

Transmission Path

The term "Transmission Path" denotes an electrical path capable of transmitting signals within the range of the service offering, e.g., a voice grade transmission path is capable of transmitting voice frequencies within the approximate range of 300 to 3000 Hz. A transmission path is comprised of physical or derived facilities consisting of any form or configuration of plant typically used in the telecommunications industry.

Trunk

The term "Trunk" denotes a communications path connecting two switching systems in a network, used in the establishment of an end-to-end connection.

ACCESS SERVICE TARIFF

SECTION 2. GENERAL REGULATIONS (Cont.)

2.6 Definitions (Cont.)

Trunk Group

The term "Trunk Group" denotes a set of trunks which are traffic engineered as a unit for the establishment of connections between switching systems in which all of the communications paths are interchangeable.

Trunk Side Connection

The term "Trunk Side Connection" denotes the connection of a transmission path to the trunk side of a local exchange switching system.

2-Wire to 4-Wire Conversion

The term "2-Wire to 4-Wire conversion" denotes an arrangement which converts a 4-wire transmission path to a 2-wire transmission path to allow a 4-wire facility to terminate in a 2-wire entity (e.g., a central office switch).

V and H Coordinated Methods

The term "V and H Coordinated Method" denotes a method of computing airline miles between two points by utilizing an established formula which is based on the vertical (V) and horizontal (H) coordinates of the two points.

WATS Serving Office

The term "WATS Serving Office" denotes a Telephone Company designated serving wire center where switching, screening and/or recording functions are performed in connection with the closed-end of WATS or WATS-type services. The use of the term "WATS" or "WATS-type" throughout this tariff is primarily for ordering purposes and is not intended to restrict the use of customers' services when ordering Special Access lines and Switched Access in combination.

Wire Center

The term "Wire Center" denotes a building in which one or more central offices, used for the provision of Telephone Exchange Services, are located.

ACCESS SERVICE TARIFF

SECTION 3. CARRIER COMMON LINE ACCESS SERVICE

The Telephone Company will provide Carrier Common Line Access Service (Carrier Common Line Access) to customers in conjunction with Switched Access Service provided in Section 6 of this tariff.

3.1 General Description

Carrier Common Line Access provides for the use of end users' Telephone Company provided common lines by customers for access to such end users to furnish Intrastate Communications.

Premium Access is (1) Switched Access Service provided to customers under this tariff which furnish intrastate MTS/WATS and (2) Switched Access Service in an end office converted to equal access.

A Special Access Surcharge, as set forth in 7.4.1(D) following, will apply to intrastate special access service provided by the Telephone Company to a customer, in accordance with regulations as set forth in section 7.2.4 following.

3.2 Limitations

3.2.1 Exclusions

Neither a telephone number nor detail billing are provided with Carrier Common Line Access. Additionally, directory listings and intercept arrangements are not included in the rates and charges for Carrier Common Line Access.

3.2.2 Access Groups

All line side connections provided in the same access group will be limited to the same features and operating characteristics.

All trunk side connections provided in the same access group will be limited to the same features and operating characteristics.

3.3 Undertaking of the Telephone Company

3.3.1 Provision of Service

Where the customer is provided Switched Access Service under other sections of this tariff, the Telephone Company will provide the use of Telephone Company common lines by a customer for access to end users at rates and charges as set forth in the Telephone Company's North Dakota General Exchange Tariff as filed with the North Dakota Public Utilities Commission.

ACCESS SERVICE TARIFF

SECTION 3. CARRIER COMMON LINE ACCESS SERVICE (Cont.)

3.3 Undertaking of the Telephone Company (Cont.)

3.3.2 Interstate and Intrastate Use

The Switched Access Service provided by the Telephone Company includes the Switched Access Service provided for both interstate and intrastate communications. The Carrier Common Line Access rates and charges as set forth in Section 10 of this Tariff apply to intrastate Switched Access Service access minutes in accordance with the rate regulations as set forth in 3.6.3 following (Percent Interstate Use - PIU).

3.4 Obligations of the Customer

3.4.1 Switched Access Service Requirement

The Switched Access Service associated with Carrier Common Line Access shall be ordered by the customer under other sections of this tariff.

3.4.2 Supervision

The customer facilities at the premises of the ordering customer shall provide the necessary on-hook and off-hook supervision.

3.5 Determination of Usage Subject to Carrier Common Line Access Charges

Except as set forth herein, all Switched Access Service provided to the customer will be subject to Carrier Common Line Access charges.

3.5.1 Determination of Jurisdiction

When the customer reports interstate and intrastate use of Switched Access Service, the associated Carrier Common Line Access used by the customer for intrastate will be determined as set forth in 3.6.3 following (Percent Interstate Use - PIU).

3.5.2 Local Exchange Access and Enhanced Services Exemption

When access to the local exchange is required to provide a customer service (e.g., MTS/WATS-type, telex, Data, etc.) that uses a resold private line service, Switched Access Service Rates and Regulations, as set forth in Section 6 following will apply, except when such access to the local exchange is required for the provision of an enhanced service.

ACCESS SERVICE TARIFF

SECTION 3. CARRIER COMMON LINE ACCESS SERVICE (Cont.)

3.6 Rate Regulations

3.6.1 Billing of Charges

Carrier Common Line charges will be billed to each Switched Access Service provided under this tariff in accordance with the regulations as set forth in 3.6.4 following, except as set forth in 3.6.3 following (PIU).

3.6.2 Measuring and Recording of Call Detail

When access minutes are used to determine Carrier Common Line charges, they will be accumulated using call detail recorded by Telephone Company equipment. The Telephone Company measuring and recording equipment will be associated with end office or local tandem switching equipment and will record each originating and terminating access minute where answer supervision is received. The accumulated access minutes will be summed on a line by line basis, by line group or by end office, whichever type of account is used by the Telephone Company, for each customer and then rounded to the nearest minute.

3.6.3 Percent Interstate Use (PIU)

When the customer reports interstate and intrastate use of in-service Switched Access Service, Carrier Common Line charges contained in this tariff will be billed only to intrastate Switched Access Service access minutes based on the data reported by the customer as set forth in 2.3.10 preceding (Jurisdictional Reports), except where the Telephone Company is billing according to actuals by jurisdiction. Intrastate Switched Access Service access minutes will, when necessary, be used to determine Carrier Common Line Charges as set forth in 3.6.4 following.

3.6.4 Determination of Charges

After the adjustments as set forth in 3.6.3 preceding have been applied, when necessary, to Switched Access Service access minutes, charges for the involved customer account will be determined as follows:

- (A) Access minutes for all Switched Access Service subject to Carrier Common Line charges will be multiplied by the Access per minute rate as set forth in Section 10 of this Tariff.

ACCESS SERVICE TARIFF

SECTION 3. CARRIER COMMON LINE ACCESS SERVICE (Cont.)

3.6 Rate Regulations (Cont.)

3.6.4 Determination of Charges (Cont.)

(B) Reserved for Future Use.

(C) Terminating Access, per minute charges(s) apply to:

- all terminating access minutes of use;
- all originating access minutes of use associated with FGA Access Services where the off-hook supervisory signaling is forwarded by the customer's equipment when the called party answers;
- all originating access minutes of use associated with calls placed to 700, toll free and 900 numbers, less those originating access minutes of use associated with calls placed to 700, toll free and 900 numbers for which the customer furnishes for each month a report of either the number of calls or minutes or a report of the percent of calls or minutes that terminate in a Switched Access Service that is assessed Carrier Common Line charges.

When the customer makes this report available to the Telephone Company in advance of billing, these minutes of use will be charged on the current bill as originating minutes of use as set forth in (D) following. If a billing dispute arises concerning the customer provided report, the Telephone Company will request the customer to provide the data the customer used to develop the report. The Telephone Company will not request such data more than once a year. The customer shall supply the data within 30 days of the Telephone Company request.

When this report is not available to the Telephone Company until after billing, it shall be used by the Telephone Company to calculate and post a credit to the customer's account. The credit shall be posted to the customer's account within 30 days of receipt of the report. The credit shall be calculated by multiplying the number of access minutes of use, for which a credit is determined to be applicable, times the difference between the terminating and originating Carrier Common Line charges in effect when the calls were completed.

ACCESS SERVICE TARIFF

SECTION 3. CARRIER COMMON LINE ACCESS SERVICE (Cont.)

3.6 Rate Regulations (Cont.)

3.6.4 Determination of Charges (Cont.)

(D) The originating Access, per minute charge(s) apply to:

- all originating access minutes of use;
- less those originating access minutes of use associated with FGA Access Services where the off-hook supervisory signaling is forwarded by the customer's equipment when the called party answers;
- less all originating access minutes of use associated with calls placed to 700, toll free and 900 numbers;
- plus all originating access minutes of use associated with calls placed to 700, toll free and 900 numbers for which the customer furnishes for each month a report of either the number of calls or minutes or a report of the percent of calls or minutes that terminate in a Switched Access Service that is assessed Carrier Common Line charges, and for which a corresponding reduction in the number of terminating access minutes of use has been made as set forth in (D) preceding.

3.7 Universal Service Charge

The Universal Service Charge (USC) recovers amounts that have traditionally been included in amounts billed to Interexchange Carriers through Interexchange Access Charges

The Telephone company will apply the USC through flat rated monthly line charges assessed to end users that are billed End User Common Line Charges and through surcharge on monthly billed charges to end users that order intrastate special access services.

3.8 Carrier Common Line Rates and Charges

"Rates can be found in Section of this Tariff

ACCESS SERVICE TARIFF

SECTION 4. END USER ACCESS SERVICE

4.1 General Description

End User Access as described in this section consists of End User Common Line (EUCL) charges and Presubscribed Interexchange Carrier Charges (PICC). Rate regulations for the EUCL and PICC are described in 4.6, following, and the rates, if applicable are contained in Section 10 of this Tariff.

4.2 Limitations

(A) Exclusions

Neither a telephone number nor detail billing is provided with End User Access. Directory listings and Intercept arrangements are not included with End User Access.

4.3 Undertaking of the Company

(A) The Telephone Company will provide use of a common line by an end user or interexchange carrier under the Tariff. Such use will be provided when the end user obtains local exchange service.

(B) The company will be responsible for contacts and arrangements with customers (end users or interexchange carriers) for the billing of End User Access rates. The End User Access rates are billed as set forth following:

(1) EUCL

When an end user obtains local exchange service from the Telephone Company, the EUCL per month rate is assessed to the end user of the associated local exchange service.

(2) PICC

The PICC is assessed to the presubscribed carrier when an end user obtains local exchange service from the Telephone Company and identifies an interexchange carrier as the presubscribed carrier. If the end user chooses not to presubscribe to an interexchange carrier, the PICC is assessed directly to the end user.

ACCESS SERVICE TARIFF

SECTION 4. END USER ACCESS SERVICE (Cont.)

4.3 Undertaking of the Company

(2) PICC (Cont.)

When a presubscribed carrier has terminated service to its end user for nonpayment or for violation of any other term or condition in the presubscribed carrier's tariff, the presubscribed carrier must provide the telephone company with the following conditions in order to avoid liability for the payment of the PICC.

- (a) The presubscribed carrier must notify the Telephone Company that it has discontinued service to its end user at least fifteen (15) days prior to the monthly PICC determination date, and in a format mutually agreed upon by the carrier and the Telephone Company. When the notification is received, the Telephone Company will change the Primary Interexchange Carrier (PIC) designation to PIC NONE. When the line designation is PIC NONE the end user must dial an access code for all intrastate calls. In the event the notice is received less than fifteen (15) days before the Telephone Company's PICC determination date, the Telephone Company will make reasonable efforts to change the end user line to a PIC NONE designation. However, if the Telephone Company will continue to assess the PICC to the carrier until the following month's determination date.
- (b) Prior to (a), preceding, the presubscribed carrier must comply with the F.C.C. and/or North Dakota Public Utilities Commission requirements to notify its presubscribed end user of the termination and explain to the customer the need to select a new primary interexchange carrier if the customer wants to continue to dial 1+ long distance calls after the termination. In addition, the presubscribed carrier must inform the presubscribed end user that the Telephone Company will assess the PICC directly to the local exchange service and user until a new primary interexchange carrier is selected.
- (c) Once the Telephone Company has received notification, as set forth in (a), preceding, the local Exchange Service end user will not be presubscribed to any primary interexchange carrier, PIC NONE, in the Telephone Company's data base. The Telephone Company will cease billing the PICC to the presubscribed carrier and will assess the PICC to the end user. The PICC will be assessed to the end user until the end user selects another primary interexchange carrier as its presubscribed carrier.
- (d) The Telephone Company is not liable for any dispute resulting from the change to PIC NONE initiated by the presubscribed carrier's notification to the Telephone Company. The presubscribed carrier shall furnish the Telephone Company with a copy of its end user notification upon request in order to resolve any end user or reseller PIC disputes.
- (e) In the event of a dispute over the PICC between the end user and the presubscribed carrier, the Telephone Company will bill the PICC to the end user when it has received notification as set forth in (a), preceding. The end user should contact the formerly presubscribed carrier to attempt to resolve termination complaint to the F.C.C. or the North Dakota Public Utilities Commission against its presubscribed carrier.

ACCESS SERVICE TARIFF

SECTION 4. END USER ACCESS SERVICE (Cont.)

4.4 Obligations of the Customer

- (A) When the end user is a Radio Common Carrier (RCC) or provider of paging service, such end users shall designate whether the local exchange service they are provided by the Telephone Company is used as an access line for RCC or paging services, or used as an administrative line.
- (B) When the end user is provided with a local exchange service which is not identified as Business or Residence service, it shall provide the Telephone Company any requested information necessary for the Telephone Company to determine the appropriate charges.

4.5 Payment Arrangements and Credit Allowances

4.5.1 Minimum Period

The minimum period for which EUCL End User Access is provided to an end user and for which charges are applicable is the same as that in the general and/or local exchange tariffs for the associated local exchange service.

4.5.2 Cancellation of Orders

End User Access is cancelled when the order for the associated local telephone exchange service is cancelled. No cancellation charges apply.

4.5.3 Changes to Orders

When changes are made to orders for the local exchange service associated with End User Access, any necessary changes will be made for End User Access. No charges will apply.

4.5.4 Allowance for Interruptions

When there is an interruption to a EUCL, requested End User Access credit allowances for interruptions will be provided as set forth for credit allowance for interruptions in 2.4.3 preceding.

4.5.5 Temporary Suspension of Service

When an end user temporarily suspends its local exchange service which is associated with EUCL, one-half of the EUCL per month charge will be temporarily suspended for the time period the local exchange service is suspended.

ACCESS SERVICE TARIFF

SECTION 4. END USER ACCESS SERVICE (Cont.)

4.6 Rate Regulations for EUCL and PICC

The EUCL and PICC rate applications are described in (A) through (O), following. The rates, if applicable, are set forth in S.

- (A) The EUCL and PICC Residence Subscriber rates, as described in (B), (C), and (I), following, are based on a Primary and Non-Primary basis. The Primary Residence rate is assessed for the first line provided at the residence. Each additional line at the same residence, regardless of the named subscriber, is assessed the Non-Primary Residence rate. If the primary line disconnects, the non-primary line with the greatest length of service becomes the primary line. A residence is defined as a self-contained housing unit that typically contains cooking and sleeping facilities.
- (B) When a customer is provided local residence exchange service by the Telephone Company, the EUCL and PICC Residence Subscriber rates apply for such local residence exchange service on a Primary and Non-Primary basis as set forth in (A), preceding.
- (C) When a customer is provided local residence exchange service by the Telephone Company and when the local residence exchange service is provided as a multiparty service, the EUCL and PICC Residence Subscriber rates are assessed for each such party on a Primary and Non-Primary basis as set forth in (A), preceding.
- (D) When a customer is provided only a single local business exchange service (excluding PAL service) by the Telephone Company, the EUCL and PICC Single Line Business Subscriber rates apply for each single business service.
- (E) When a customer is provided only a single local business exchange service (excluding PAL service) by the Telephone Company and when the local business exchange service is provided as a multiparty service, the EUCL and PICC Single Line Business Subscriber rates apply for each such party.
- (F) When a customer is provided a single Public Access Line (PAL) by the Telephone Company, the EUCL and PICC Multiline Business Subscriber rates apply for each such PAL.
- (G) When a customer is provided more than one local business exchange service in a state by the same Telephone Company, the EUCL and PICC Multiline Business Subscriber rates are assessed for each line.
- (H) When a customer is provided DSS by the Telephone Company, the EUCL and PICC Multiline Business Subscriber rates apply for every channel (24 channels) on the T-1 facility.
- (I) Centrex is a service that (1) utilizes a dedicated common block in a Company switch located at the Telephone Company central office to meet the customer's internal needs and serves as the customer's interface with the local and interexchange networks, (2) links the customer's main stations to the Telephone Company central office with subscriber loops, (3) allows Network Access Registers (NARs) to be associated with the service and (4) allows abbreviated dialing within the common block.

ACCESS SERVICE TARIFF

SECTION 4. END USER ACCESS SERVICE (Cont.)

4.6 Rate Regulations for EUCL and PICC (Cont.)

For business Centrex station lines (excluding Integrated Services Digital Network Basic Rate Interface within a Centrex system), the EUCL Multiline Business Subscriber rate applies for each line. The PICC is assessed on a per Centrex station line basis.

Centrex Dormitory (Residential) Service is a service to a college, university or school that serves student or faculty dormitory (residential) quarters. Primary and Non-Primary Residential EUCL and PICC rates apply for the station lines that serve dormitory quarters, as set forth in (A), preceding. EUCL Multiline Business Subscriber and PICC Centrex Subscriber rates apply to the station lines that serve the school offices as set forth above.

- (J) When a customer is provided Integrated Service Digital Network Basic Rate Interface (ISDN-BRI) that permits the provision of two voice-grade-equivalent channels and a signaling/data channel over a single facility, the ISDN-BRI EUCL Subscriber rate and the ISDN-BRI PICC rates are assessed for each such facility. When the ISDN-BRI is provided within a Centrex system, the ISDN-BRI rate applications apply.
- (K) When a customer is provided Integrated Services Digital Network Primary Rate Interface (ISDN-PRI) that permits the provision of up to 24 voice-grade-equivalent channels over a single T-1 facility, the EUCL Multiline Business Subscriber rate is multiplied by five for each such T-1 facility. The ISDN-PRI PICC rate is assessed once for each such T-1 facility.
- (L) When a customer is provided a local exchange service which is not identified as Business, Centrex, DSS, ISDN or Residence service (e.g., Farm Service, Local Service), the Telephone Company will designate the service as either Business, Centrex, DSS, ISDN or Residence Service per 4.4.(B), preceding. The rates, as set forth in Section 10 of this Tariff, for EUCL and PICC will apply in accordance with the designation.
- (M) For each local exchange service provided as Remote Call Forwarding (RCF) residential or Remote Call Forwarding business service, under the general and/or local exchange service tariffs, EUCL and PICC rates do not apply.
- (N) EUCL and PICC rates are assessed for each local exchange service provided under the general and/or local exchange service tariffs to Commercial Mobile Radio Service providers which are used for administrative purposes.

ACCESS SERVICE TARIFF

SECTION 4. END USER ACCESS SERVICE (Cont.)

4.6 Rate Regulations for EUCL and PICC (Cont.)

(O) Reserved for Future Use

4.7 Rates and Charges

Rates and charges can be found in Section 10 of this Tariff.

ACCESS SERVICE TARIFF

SECTION 5. ORDERING OPTIONS FOR SWITCHED AND SPECIAL ACCESS SERVICE

5.1 General

This section sets forth the regulations for Access Orders for Switched and Special Access Services.

An Access Order is an order to provide the customer with Switched Access Service or Special Access Service or to provide changes to existing services.

5.1.1 Ordering Conditions

A customer may order any number of services of the same type between the same premises on a single Access Order. All details for services for a particular order must be identical except for those for multi-point service.

The customer shall provide all information necessary for the Telephone Company to provide and bill for the requested service. In addition to the order information required in 5.2 following, the customer must also provide:

- Customer name and premises address(es).
- Billing name and address (when different from customer name and address).
- Customer contact name(s) and telephone number(s) for the following provisioning activities: order negotiation, order confirmation, interactive design, installation and billing.

Orders for Feature Group A Switched Access Service shall be in lines.

5.2 Access Order

An Access Order is used by the Telephone Company to provide to a customer Access Service as follows:

- Switched Access Services as set forth in Section 6 following, and
- Special Access Service as described in Section 7 following.

When a placing an order for Access Service, the customer shall provide, at a minimum, the following information:

- For Feature Group A Switched Access Service, the customer shall specify the number of lines and the first point of switching (i.e., dial tone office), the Local Transport options and Local Switching options desired. In addition, the customer shall specify whether the off-hook supervisory signaling is provided by the customer's equipment before the called party answers, or is forwarded by the customer's equipment when the called party answers. The customer shall also specify which lines are to be arranged in multi-line hunt group arrangements and which lines are to be provided as single lines.

ACCESS SERVICE TARIFF

SECTION 5. ORDERING OPTIONS FOR SWITCHED AND SPECIAL ACCESS SERVICE
(Cont.)

5.2 Access Order (Cont.)

- For Feature Group B Switched Access Service, the order shall be placed with the exchange telephone company in whose service area the access tandem is located. The Telephone Company has no access tandems and carries Feature Group B traffic only as a Secondary Exchange Carrier.
- For Feature Group D Switched Access Service, the customer shall specify the number of busy hour minutes of capacity (BHMC) from the customer's premises to the end office. This information is used to determine the number of transmission paths as set forth in Section 6 following.
- Feature Group D may also be ordered for use in conjunction with Toll Free Number Data Base Access Services.
- For all Special Access Services, the customer must specify the customer premises involved, the type of service (e.g., Voice Grade), the options desired, and the Percent Interstate Usage (PIU) as greater or less than 10%, in accordance with Section 2.3.10(A)(7), preceding.

The BHMC may be determined by the customer in the following manner. For each day (8 a.m. to 11 p.m., Monday through Friday, excluding national holidays), the customer shall determine the highest number of minutes of use for a single hour (e.g., 55 minutes in the 10-11 a.m. hour). The customer shall, for the same hour period (i.e., busy hour) for each of twenty consecutive business days, pick the twenty consecutive business days in a calendar year which add up to the largest number of minutes of use. Both originating and terminating minutes shall be included. The customer shall then determine the average busy hour minutes of capacity (i.e., BHMC) by dividing the largest number of minutes of use figure for the same hour period for the consecutive twenty business day period by 20. This computation shall be performed for each end office the customer wishes to serve. These determinations thus establish the forecasted BHMC for each end office.

5.2.1 Access Order Service Date Intervals

- (A) To the extent the Access Service can be made available with reasonable effort, the Telephone Company will provide the Access Service in accordance with the customer's requested interval, subject to the following conditions:
 - (1) The Telephone Company shall make available to all customers upon placement of an access order a schedule of applicable service dates for Switched and Special Access Services. The schedule shall specify the applicable service date for services and the quantities of services that can be provided in the applicable service date.

ACCESS SERVICE TARIFF

SECTION 5. ORDERING OPTIONS FOR SWITCHED AND SPECIAL ACCESS SERVICE
(Cont.)

5.2 Access Order (Cont.)

5.2.1 Access Order Service Date Intervals (Cont.)

- (2) When the customer requests a service date before or beyond the applicable service date.

The Telephone Company will offer a service date based on the type and quantity of Access Services the customer has requested. The requested service date may not exceed by more than six months the applicable service date, or, when there is no applicable service date, the Telephone Company offered service date.

5.2.2 Access Order Modifications

The customer may request a modification of its Access Order prior to the service date. The Telephone Company will make every effort to accommodate a requested modification when it is able to do so with the normal work force assigned to complete such an order within normal business hours. If the modification cannot be made with the normal work force during normal business hours, the Telephone Company will notify the customer. If the customer still desires the Access Order modification the Telephone Company will schedule a new service date.

5.2.3 Cancellation of an Access Order

- (A) A customer may cancel an Access Order for the installation of service on any date prior to the service date. The cancellation date is the date the Telephone Company receives written or verbal notice from the customer that the order is to be cancelled. The verbal notice must be followed by written confirmation within 10 days. If a customer or a customer's end user is unable to accept Access Service within 30 calendar days after the original service date, the customer has the choice of the following options:

- The Access Order shall be cancelled and charges set forth in (B) following will apply, or
- Billing for the service will commence.

In such instances, the cancellation date or the billing date, depending on which option is selected by the customer, shall be the 31st day beyond the original service date of the Access Order.

ACCESS SERVICE TARIFF

SECTION 5. ORDERING OPTIONS FOR SWITCHED AND SPECIAL ACCESS SERVICE
(Cont.)

5.2 Access Order (Cont.)

5.2.3 Cancellation of an Access Order (Cont.)

- (B) When a customer cancels an Access Order for the installation of service, a Cancellation Charge will apply as follows:
- (1) Installation of Switched or Special Access Service facilities is considered to have started when the Telephone Company incurs any cost in connection therewith or in preparation thereof which would not otherwise have been incurred.
 - (2) Where the customer cancels an Access Order prior to the start of installation of access facilities, no charges shall apply.
 - (3) Where installation of access facilities has been started prior to the cancellation, the charges specified in (a) or (b) following, whichever is lower, shall apply.
 - (a) A charge equal to the cost incurred in such installation, less estimated net salvage. Such charge is determined as detailed in (4) following.
 - (b) The charge for the minimum period of Switched or Special Access Service ordered by the customer.
 - (4) Charges applicable as specified in (3)(a) preceding include the non-recoverable cost of equipment and material ordered, provided or used, plus the non-recoverable cost of installation and removal including the costs of engineering, labor, supervision, transportation, rights-of-way and other associated costs.
- (C) When a customer cancels an order for the discontinuance of service, no charges apply for the cancellation.
- (D) If the Telephone Company misses a service date by more than 30 days due to circumstances over which it has direct control (excluding, e.g., acts of God, governmental requirements, work stoppages and civil commotions), the customer may cancel the Access Order without incurring cancellation charges.

ACCESS SERVICE TARIFF

SECTION 5. ORDERING OPTIONS FOR SWITCHED AND SPECIAL ACCESS SERVICE
(Cont.)

5.2 Access Order (Cont.)

5.2.4 Selection of Facilities for Access Orders

- (A) When there are analog or digital high capacity facilities to a Hub on order or in service for a customer's use, the customer may request a specific facility or transmission path be used to provide the Switched or Special Access Service requested in an Access Order. The Telephone Company will make a reasonable effort to accommodate the customer request.
- (B) For all other Access Orders, the option to request a specific transmission path or facility is not provided.

5.2.5 Minimum Period

Except as specifically set forth in other sections of this Tariff, the minimum period for which charges are applicable is one month.

5.2.6 Minimum Period Charges

When Access Service is discontinued prior to the expiration of the minimum period, charges are applicable for the balance of the minimum period. A disconnect constitutes facilities being returned to inventory.

The Minimum Period Monthly Charge for a month or fraction thereof is the applicable monthly rate for the service as set forth in Section 6 (for Switched Access) or Section 7 (for Special Access) following.

5.2.7 Access Orders for Services Provided by More than One Telephone Company

Access Services provided by more than one Telephone Company are services where one end of the Local Transport or Channel Mileage element is in the operating territory of one Telephone Company and the other end of the element is in the operating territory of a different Telephone Company or where the end office and the office providing Toll Free Number Data Base queries are in the operating territories of different Telephone Companies.

The ordering procedure for this service is dependent upon the billing arrangement, as set forth in 2.4.6 preceding, to be used by the Telephone Companies involved in providing the Access Service.

ACCESS SERVICE TARIFF

SECTION 5. ORDERING OPTIONS FOR SWITCHED AND SPECIAL ACCESS SERVICE
(Cont.)

5.2 Access Order (Cont.)

5.2.7 Access Orders for Services Provided by More than One Telephone Company
(Cont.)

Each Telephone Company will provide its portion of the Access Service within its operating territory to an interconnection point(s) (IP) with the other Telephone Company. The interconnection point(s) and Billing Percentages will be determined by the Telephone Companies involved in providing the Access Service and listed in Exchange Carrier Association F.C.C. Tariff No. 4. Each Telephone Company will bill the customer for its portion of the service as set forth in 2.4.6. All other appropriate charges in each Telephone Company tariff are applicable.

- (A) For Feature Group A and B Switched Access Services, the access customer must place an order with the Telephone Company in whose territory the customer's first point of switching is located, (i.e., FGA – dial tone office, FGB - access tandem). For FGB, the customer shall furnish a copy of the order to the Telephone Company, which has no access tandems and which serves as a Secondary Exchange Carrier.
- (B) For Feature Group D Switched Access Service, the customer must place an order with the Telephone Company in whose territory the end office is located. Customers may, at their option, order FGD to the access tandem. When ordered to the access tandem, and the access tandem and the end office are not in the same Telephone Company operating territory, the customer must also supply a copy of the order to each additional Telephone Company subtending the access tandem. Failure or delay in supplying a copy of the order to the Telephone Company shall not negate the responsibility of the customer to pay for access traffic terminated to the telephone company's network pursuant to the Telephone Companies tariff rates.
- (C) Customers ordering Special Access Service to be interconnected with Switched Access Services at Telephone Company designated WATS Serving Offices for the provision of WATS or WATS-type Services must place an order with each Telephone Company in whose territory the end office and the WATS Serving Office are located, if they are not collocated.

ACCESS SERVICE TARIFF

SECTION 5. ORDERING OPTIONS FOR SWITCHED AND SPECIAL ACCESS SERVICE
(Cont.)

5.2 Access Order (Cont.)

5.2.7 Access Orders for Services Provided by More than One Telephone Company
(Cont.)

- (D) Except for Special Access Service as set forth in (C) above, the customer may place the order for a Special Access Service with either Exchange Telephone Company.
- (E) For initiation, additions, changes or deletions to Toll Free Number Data Base Access Services, the customer must place an order with the Telephone Company that performs the Toll Free Number Data Base queries. The customer must also provide a copy of the order to the Telephone Companies subtending the office that launches the queries.
- (F) For the service(s) ordered as set forth preceding, the customer must also supply a copy of the order to the Telephone Company in whose operating territory a customer designated premises is located and any other Telephone Company(s) involved in providing the service, including Secondary Exchange Carriers.

5.3 Charges Associated with Access Ordering

The Access Order Charge is applied to all customer requests for new Special Access and Switched Access. In addition, the Access Order Charge is applicable to customer requests for additions, changes or rearrangements to existing Special Access, and Switched Access services with the following exceptions:

The Access Order Charge does not apply:

- When a Service Date Change Charge is applicable.
- When a Design Change Charge is applicable.
- To administrative changes.
- When a change to a pending order does not result in the cancellation of the pending order and the issuance of a new order.
- When the Interim NXX Translation charge is applicable.
- When a Miscellaneous Service Order Charge is applicable.

ACCESS SERVICE TARIFF

SECTION 5. ORDERING OPTIONS FOR SWITCHED AND SPECIAL ACCESS SERVICE
(Cont.)

5.3 Charges Associated with Access Ordering (Cont.)

- When a Presubscription Charge is applicable.
- When a Telephone Company initiated network reconfiguration requires a customer's existing access service to be reconfigured.
- When a service with an ICB rate is converted to a similar service with a non-ICB tariff rate prior to the expiration of the ICB.
- When a Billing Name and Address Order charge is applicable.
- When a 900 Blocking Service charge is applicable.
- When a customer with a Special Access DS3 Capacity Discount converts to Special Access Synchronous Optical Channel Service.
- When Payphone Service Providers (PSPs) obtain Coin Supervision Additive Service in conjunction with local exchange service lines for the provision of pay telephone service.

The Access Order Charge will be applied on a per order basis to each order received by the Telephone Company or copy of an order received by the Telephone Company pursuant to 5.2.7 preceding.

The Access Order Charge will be applied on a per order basis for any change, rearrangement or addition to the delivery of signaling to an existing STP Port.

The Access Order Charge will be applied on a per order basis for any change, rearrangement or addition of CICs to an existing Feature Group B or Feature Group D trunk group.

ACCESS SERVICE TARIFF

SECTION 6. SWITCHED ACCESS SERVICE

6.1 General

Switched Access Service, which is available to customers for their use in furnishing their services to end users, provides a two-point electrical communications path between a customer designated premise and an end user's premises. It provides for the use of common terminating, switching and trunking facilities, and common subscriber plant of the Telephone Company. Switched Access Service provides for the ability to originate calls from an end user's premises to a customer designated premise, and to terminate calls from a customer designated premise to an end user's premises in the LATA where it is provided.

Rates and charges for Switched Access Service depend generally on its use by the customer, i.e., for MTS or WATS services, or MTS-WATS equivalent services, and whether it is provided in a Telephone Company end office that is equipped to provide equal or non equal access. Rates and charges for Switched Access Service are located in Section 10 of this Tariff. Rates and charges for services other than Switched Access Service, e.g., a customer's interLATA toll message service, may also be applicable when Switched Access Service is used in conjunction with these other services.

The following provision applies to the treatment of Toll VoIP - PSTN Traffic pursuant to the Federal Communications Commission's Part 51 Interconnection Rules and in compliance with the Federal Communications Commission's Report and Order and Further Notice of Proposed Rulemaking in CC Docket Nos. 96-45 and 01-92; GN Docket No. 09-51; WC Docket Nos. 03-109, 05-337, 07-135 and 10-90; and WT Docket No. 10-208, adopted October 27, 2011 and released November 18, 2011 (FCC 11-161). In the absence of an interconnection agreement between the Telephone Company and the customer specifying the treatment of Toll VoIP-PSTN Traffic, the Telephone Company will bill the customer the applicable Interstate switched access rates and charges¹ specified in Section 10 of this Tariff, following, on all jurisdictionally Intrastate voice traffic identified as Toll VoIP-PSTN Traffic². These provisions only apply to those Issuing Carriers shown as providing the service in Section 10 of this Tariff Following.

¹ Including Interstate Transport structure.

² Pursuant to the FCC's Second Order on Reconsideration in the above referenced dockets, originating intrastate Toll VoIP – PSTN traffic shall be billed using relevant intrastate access rates from July 13, 2012 until June 30, 2014.

ACCESS SERVICE TARIFF

SECTION 6. SWITCHED ACCESS SERVICE (Cont'd)

6.1.1 Feature Group Arrangements and Manner of Provision

Switched Access Service is provided in three service categories of standard and optional features called Feature Groups. These are differentiated by their technical characteristics, e.g., line side vs. trunk side connection at the Telephone Company entry switch, and the manner in which an end user accesses them in originating a call, e.g., with or without an access code. Following is a brief description of each Feature Group arrangement.

(A) Feature Group A (FGA)

FGA Access, which is available to all customers, provides line side access to Telephone Company end office switches with an associated seven digit local telephone number for originating communications from and terminating communications to an Interexchange Carrier's Intrastate Service or a customer-provided Intrastate communications capability. The customer must specify the Interexchange Carrier to which the FGA service is connected or, in the alternative, specify the means by which the FGA access communications is transported to another state. The rates applicable to FGA Access Service as set forth in Section 10 of this Tariff also apply to traffic that makes use of FGA facilities of another exchange carrier but that originates or terminates over the Telephone Company's toll trunks or Extended Area Service trunks. A more detailed description of FGA Access is provided in 6.2.1 following.

ACCESS SERVICE TARIFF

SECTION 6. SWITCHED ACCESS SERVICE (Cont.)

6.1 General (Cont.)

6.1.1 Feature Group Arrangements and Manner of Provision (Cont.)

(B) Feature Group B (FGB)

FGB Access, which is available to all customers at suitably equipped telephone company end offices and access tandems, provides trunk side access to telephone company end office switches with an associated uniform access code (generally 950-1XXX or 950-0XXX) for the customer's use in originating communications from and terminating communications to an Interexchange Carrier's Intrastate service or a customer provided Intrastate communications capability. The customer must specify the Interexchange Carrier to which the FGB service is connected or, in the alternative, specify the means by which the FGB access communications is transported to another state. Special Access Services utilized for connection with FGB at telephone company designated WATS Serving Offices as set forth in 7. following may be ordered separately by a customer other than the customer which orders the FGB Switched Access Service for the provision of WATS-type services. Special Access Services are ordered as set forth in 5.2 preceding.

The Telephone Company provides FGB service only as a Secondary Exchange Carrier at this time.

(C) Feature Group D (FGD)

FGD Access, which is available to all customers, provides trunk side access to Telephone Company end office switches with an associated uniform 10XXX access code for the customer's use in originating and terminating communications. Special Access Services utilized for connection with FGD at Telephone Company designated WATS serving offices may be ordered separately by a customer other than the customer which orders the FGD Switched Access Service. Special Access Services are ordered as set forth in 5.2 ("Access Order") preceding. A more detailed description of FGD Access is provided in 6.2.4 following.

(D) Manner of Provision

Switched Access is furnished in quantities of lines or in busy hour minutes of capacity (BHMCs). FGA Access is furnished on a per-line basis. FGB access is provided on a per-trunk basis. FGD Access is furnished in busy hour minutes of capacity (BHMCs). FGD may also be provided to customers other than MTS/WATS providers on a per trunk basis as set forth in 5.2 preceding.

ACCESS SERVICE TARIFF

SECTION 6. SWITCHED ACCESS SERVICE (Cont.)

6.1 General (Cont.)

6.1.1 Feature Group Arrangements and Manner of Provision (Cont.)

(D) Manner of Provision (Cont.)

BHMCs are differentiated by type and directionality of traffic carried over a Switched Access Service arrangement. Differentiation of traffic among BHMC types is necessary for the Telephone Company to properly design Switched Access Service to meet the traffic carrying capacity requirement of the customer.

There are two major BHMC categories identified as Originating and Terminating. Originating BHMCs represent access capacity within a LATA for carrying traffic from the end user to the customer; and Terminating BHMCs represent access capacity within a LATA for carrying traffic from the customer to the end user. When ordering capacity for FGD Access, the customer must at a minimum specify such access capacity in terms of Originating BHMCs and/or Terminating BHMCs.

Because some customers will wish to further segregate their originating traffic into separate trunk groups, Originating BHMCs are further categorized into Domestic, Toll Free, 900, Operator and International DDD (IDDD). Domestic BHMCs represent access capacity for carrying only domestic traffic other than Toll Free, 900 and Operator traffic; IDDD BHMCs represent access capacity for carrying only international traffic; and, Toll Free, 900 and Operator BHMCs represent access capacity for carrying, respectively, only Toll Free, 900 or Operator traffic. When ordering such types of access capacity, the customer must specify Domestic, Toll Free, 900, Operator or IDDD BHMCs.

6.1.2 Rate Categories

(A) There are three rate categories which apply to Switched Access Service:

- Local Transport (described in 6.1.2(B) following)
- End Office (described in 6.1.2(C) following)
- Common Line (described in Sections 3 and 4 preceding)

ACCESS SERVICE TARIFF

SECTION 6. SWITCHED ACCESS SERVICE (Cont.)

6.1 General (Cont.)

6.1.2 Rate Categories (Cont.)

The following diagram depicts a generic view of the components of Switched Access Service and the manner in which the components are combined to provide a complete Access Service.

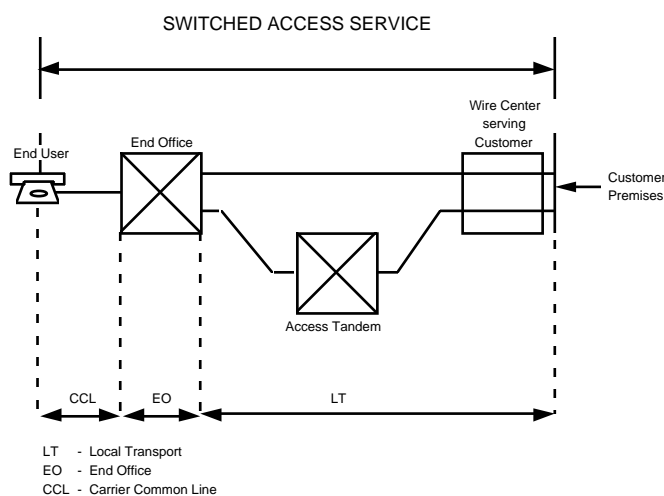

(B) Local Transport

The Local Transport rate category establishes the charges related to the transmission and tandem switching facilities between the customer designated premises and the end office switch(es).

Local Transport is a two-way voice frequency transmission path composed of facilities that permit the transport of calls in the originating direction and in the terminating direction, but not simultaneously. The voice frequency transmission path may be comprised of any form or configuration of plant capable of and typically used in the telecommunication industry for the transmission of voice and associated telephone signals within the frequency bandwidth of approximately 300-3000 Hz.

The Telephone Company will work cooperatively with the customer to determine whether the service is to be directly routed or routed through an access tandem switch. For tandem routed traffic the tandem switch shall be determined by the telephone company and specified in Local Exchange Routing Guide (LERG).

ACCESS SERVICE TARIFF

SECTION 6. SWITCHED ACCESS SERVICE (Cont.)

6.1 General (Cont.)

6.1.2 Rate Categories (Cont.)

(B) Local Transport (Cont.)

When ordering service, customers must specify the directionality of the service, and when multiplexing is required, the hub(s) at which multiplexing will be provided. When service is directly routed, the customer must specify whether the Direct Trunked Transport will overflow to Tandem Switched Transport.

Unless otherwise ordered by the F.C.C. and/or the North Dakota Public Utilities Commission, where the Telephone Company elects to provide equal access through a Centralized Equal Access arrangement, the Telephone Company will designate the serving wire center. The designated SWC will normally be that wire center which provides dial tone to the telephone company Centralized Equal Access tandem office identified in National Exchange Carrier Association F.C.C. Tariff No. 4. When service is provided in cooperation with a non telephone company provider of Centralized Equal Access, the SWC will be that wire center which would normally provide dial tone to the telephone company point of interconnection with the non telephone company provider of Centralized Equal Access specified in the tariff of the Centralized Equal Access provider.

Local Transport is provided at the rates and charges set forth in Section 10 following. When more than one Telephone Company is involved in providing the Switched Access Service, the Local Transport rates will be applied as set forth in Section 2.4.6.

The Local Transport rate category includes the following classifications of rate elements: Direct Trunked Transport, Tandem Switched Transport, Transport Interconnection Charge, and Multiplexing.

(1) Entrance Facility

Entrance Facility recovers a portion of the costs associated with the communications path between a customer designated premises and the serving wire center of that premises. Included as part of the Entrance Facility is a standard channel interface arrangement which defines the technical characteristics associated with the type of signaling capability, if any.

ACCESS SERVICE TARIFF

SECTION 6. SWITCHED ACCESS SERVICE (Cont.)

6.1 General (Cont.)

6.1.2 Rate Categories (Cont.)

(B) Local Transport (Cont.)

(1) Entrance Facility (Cont.)

Three types of Entrance Facility are available: (1) Voice Grade 2 or 4 wire (an analog channel with an approximate bandwidth of 300 to 3000 hz) (2) High Capacity DS1 (an isochronous serial digital channel with a rate of 1.544 Mbps), and (3) High Capacity DS3 (an isochronous serial digital channel with a rate of 44.736 Mbps).

One charge applies for each Entrance Facility that is terminated at a customer designated premises. This charge will apply even if the customer designated premises and the serving wire center are collocated in a Telephone Company building.

At customer request, their Local Transport may be connected to the Entrance Facility of another customer, providing the other customer requests this connection and assumes full responsibility for the cost of the Entrance Facility.

(2) Direct Trunked Transport

Direct Trunked Transport provides a transmission path between a serving wire center and an end office or serving wire center and a tandem on dedicated circuits, without utilizing tandem switching functions.

Direct Trunked Transport is not available: (1) from end offices that provide equal access through a Centralized Equal Access arrangement, or (2) from end offices that lack recording or measurement capability.

ACCESS SERVICE TARIFF

SECTION 6. SWITCHED ACCESS SERVICE (Cont.)

6.1 General (Cont.)

6.1.2 Rate Categories (Cont.)

(B) Local Transport (Cont.)

(2) Direct Trunked Transport (Cont.)

Two types of Direct Trunked Transport are available: (1) Voice Grade, and (2) High Capacity DS1. Direct Trunked Transport rates, specified in Section 10 following, consist of a Direct Trunked Facility rate which is applied on a per mile basis and a Direct Trunked Termination rate which is applied at each end of each measured segment of the Direct Trunked Facility. When the Direct Trunked Facility mileage is zero, neither the Direct Trunked Facility rate nor the Direct Trunked Termination rate will apply.

(3) Tandem Switched Transport

Tandem Switched Transport provides a communications path between an access tandem and an end office on circuits that utilize tandem switching functions. Tandem Switched Transport rates consist of a Tandem Switched Facility rate and a Tandem Switched Termination rate, found in Section 10 following.

The Tandem Switched Facility rate applies on a per access minute per mile basis for all originating and terminating MOU routed over the facility. The Tandem Switched Termination rate applies on a per access MOU basis at each end of each measured segment of Tandem Switched Facility. When the Tandem Switched Facility mileage is zero, neither the Tandem Switched Facility rate nor the Tandem Switched Termination rate will apply.

(4) Transport Interconnection Charge

The Transport Interconnection Charge recovers the costs associated with Local Transport that are not recovered by the Direct Trunked Transport, Tandem Switched Transport or Multiplexing rates. The Transport Interconnection Charge specified in Section 10 following applies to both Tandem Switched and Direct Trunked access MOU.

ACCESS SERVICE TARIFF

SECTION 6. SWITCHED ACCESS SERVICE (Cont.)

6.1 General (Cont.)

6.1.2 Rate Categories (Cont.)

(B) Local Transport (Cont.)

(5) Tandem Switching

The Tandem Switching rate recovers a portion of the costs of switching traffic through an access tandem. The Tandem Switching rate specified in Section 10 following is applied on a per access minute per tandem basis for all originating and all terminating minutes of use switched at the tandem.

(6) Multiplexing

DS1 to Voice Grade Multiplexing charges apply when a High Capacity DS1 Direct Trunked Facility is connected with Voice Grade Direct Trunked Transport. However, a DS1 to Voice Grade Multiplexing Charge does not apply when High Capacity DS1 Direct Trunked Transport is terminated at an electronic end office, and only Switched Access Service is provided over the DS1 facility (i.e., Voice Grade Special Access channels are not derived). The DS1 to Voice Grade multiplexer will convert a 1.544 Mbps channel to 24 Voice Grade channels.

ACCESS SERVICE TARIFF

SECTION 6. SWITCHED ACCESS SERVICE (Cont.)

6.1 General (Cont.)

6.1.2 Rate Categories (Cont.)

(C) End Office

The End Office rate category provides the local end office switching and end user termination functions necessary to complete the transmission of Switched Access communications to and from the end users served by the local end office. The End Office rate category includes the Local Switching, Information, and Toll Free Number Data Base Query rate elements.

(1) Local Switching

The Local Switching rate element provides for the use of end office switching equipment.

Where end offices are appropriately equipped, international dialing may be provided. International dialing provides the capability of switching international calls with service prefix and address codes having more digits than are capable of being switched through a standard FGD equipped end office.

The Local Switching rate element also provides the terminations for the end user lines terminating in the local end office.

There are two types of line terminations, i.e., Common Line terminations and Special Access Service terminations utilized in the provision of WATS or WATS-type services at Telephone Company designated WATS Serving Offices.

The above Special Access Service terminations are differentiated by line side vs. trunk side terminations. In addition, there are various types of originating and terminating line side terminations depending on the type of signaling associated with the Special Access Service. Line side terminations are available with either dial pulse or dual tone multifrequency address signaling.

Local Switching rates are set forth in Section 10 of this Tariff. The application of these rates with respect to individual Feature Groups is as set forth in 6.6.1(C) following.

ACCESS SERVICE TARIFF

SECTION 6. SWITCHED ACCESS SERVICE (Cont.)

6.1 General (Cont.)

6.1.2 Rate Categories (Cont.)

(C) End Office (Cont.)

(2) Information

Information rates are set forth in Section 10 of this Tariff. The application of these rates with respect to individual Feature Groups is as set forth in 6.6.1 following.

(3) Toll Free Number Data Base Query

Toll Free Number Data Base Query charges are set forth in Section 10 of this Tariff. Toll Free Number Data Base Access Services are offered in conjunction with Toll Free Number Access Service, which is offered to Feature Group D access customers and is described in 6.2.5.

In providing originating access for toll free (i.e., 1-800-NXX-XXXX, 1-888-NXX-XXXX) calls, the Telephone Company will identify the appropriate carrier for each Toll Free Number call by querying, via its common channel signaling system (SS7) network, a data base that stores the carriers selected by Toll Free Number service customers. The Telephone Company performing the query will forward the call to the appropriate carrier and will also provide such vertical features as POTS translation and specialized call handling and verification.

The Toll Free Number Data Base Query charges for basic and vertical services will be assessed on a per query basis.

6.1.3 Design Layout Report

At the request of the customer, the Telephone Company will provide to the customer the makeup of the facilities and services provided from the customer designated premise to the first point of switching. This information will be provided in the form of a Design Layout Report. The Design Layout Report will be provided to the customer at no charge, and will be reissued or updated whenever these facilities are materially changed.

6.1.4 Acceptance Testing

At no additional charge, the Telephone Company will at the customer's request cooperatively test installed services at the time of installation. Tests to be conducted will be as mutually agreed upon by the Telephone Company and the customer.

ACCESS SERVICE TARIFF

SECTION 6. SWITCHED ACCESS SERVICE (Cont.)

6.1 General (Cont.)

6.1.5 Ordering Options and Conditions

Switched Access Service is ordered under the Access Order provisions set forth in Section 5 preceding.

6.2 Description of Switched Access Service Feature Groups

Following are detailed descriptions of each of the available Feature Groups. Each Feature Group is described in terms of its specific physical characteristics and calling patterns.

6.2.1 Feature Group A (FGA)

(A) Description

- (1) FGA is provided in connection with Telephone Company electronic and electromechanical end offices. At the option of the customer, FGA is provided on a single or multiple line group basis and is arranged for originating calling only, terminating calling only or two-way calling.
- (2) FGA provides a line side termination at the first point of switching (dial tone office). The line side termination will be provided with either ground start supervisory signaling or loop start supervisory signaling. The type of signaling is at the option of the customer.
- (3) The Telephone Company shall select the first point of switching, within the selected LATA, at which the line side termination is to be provided unless the customer requests a different first point of switching and Telephone Company facilities and measurement capabilities, where necessary, are available to accommodate such a request.
- (4) A seven digit local telephone number assigned by the Telephone Company is provided for access to FGA switching in the originating direction. The seven digit local telephone number will be associated with the selected end office switch and is of the form NXX-XXXX.

If the customer requests a specific seven digit telephone number that is not currently assigned, and the Telephone Company can, with reasonable effort, comply with that request, the requested number will be assigned to the customer.

ACCESS SERVICE TARIFF

SECTION 6. SWITCHED ACCESS SERVICE (Cont.)

6.2 Description of Switched Access Service Feature Groups (Cont.)

6.2.1 Feature Group A (FGA) (Cont.)

(A) Description (Cont.)

- (5) FGA switching, when used in the terminating direction, is arranged with dial tone start-dial signaling. When used in the terminating direction FGA switching may, at the option of the customer, be arranged for dial pulse or dual tone multifrequency address signaling, subject to availability of equipment at the first point of switching. When FGA switching is provided in a hunt group or uniform call distribution arrangement, all FGA switching will be arranged for the same type of address signaling.
- (6) No address signaling is provided by the Telephone Company when FGA Switching is used in the originating direction. Address signaling in such cases, if required by the customer, must be provided by the customer's end user using inband tone signaling techniques. Such inband tone address signals will not be regenerated by the Telephone Company and will be subject to the ordinary transmission capabilities of the Local Transport provided.
- (7) FGA switching, when used in the terminating direction, may be used to access valid NXXs in the LATA, local operator service (0- and 0+), Directory Assistance (411 where available and 555-1212), emergency reporting service (911 where available), exchange telephone repair (611 where available), time or weather announcement services of the Telephone Company, community information services of an information service provider, and other customers' services (by dialing the appropriate digits). Charges for FGA terminating calls requiring operator assistance or calls to 611 or 911 will only apply where sufficient call details are available. Additional non-access charges will also be billed on a separate account for (1) an operator surcharge, as set forth in the local exchange tariffs, for local operator assistance (0- and 0+) calls, (2) calls to certain community information services, for which rates are applicable under Telephone Company exchange service tariffs, e.g., 976 (DIAL-IT) Network Services, and, (3) calls from a FGA line to another customer's service in accordance with that customer's applicable service rates when the Telephone Company performs the billing function for that customer.

ACCESS SERVICE TARIFF

SECTION 6. SWITCHED ACCESS SERVICE (Cont.)

6.2 Description of Switched Access Service Feature Groups (Cont.)

6.2.1 Feature Group A (FGA) (Cont.)

(A) Description (Cont.)

- (8) When a FGA switching arrangement for an individual customer (a single line or entire hunt group) is discontinued at an end office, an intercept announcement is provided. This arrangement provides, for a limited period of time, an announcement that the service associated with the number dialed has been disconnected.

6.2.2 Feature Group B (FGB)

(A) Description

- (1) FGB service is provided only on a Secondary Exchange Carrier basis by the Telephone Company. Sections 6.2.2(A)(2) through 6.2.2(A)(8) below will apply if and when such facilities are available.
- (2) When directly routed to an end office (i.e., provided without the use of an access tandem switch), FGB is provided at appropriately equipped telephone company electronic end office switches. When provided via telephone company designated electronic access tandem switches, FGB switching is provided at telephone company electronic and electromechanical end office switches.
- (3) FGB is provided as trunk side switching through the use of end office or access tandem switch trunk equipment. The switch trunk equipment is provided with wink start start-pulsing signals and answer and disconnect supervisory signaling.
- (4) FGB switching is provided with multifrequency address signaling in both the originating and terminating directions. Except for FGB switching provided with the automatic number identification (ANI) or rotary dial station signaling arrangements, any other address signaling in the originating direction, if required by the customer, must be provided by the customer's end user using inband tone signaling techniques. Such inband tone address signals will not be regenerated by the telephone company and will be subject to the ordinary transmission capabilities of the Local Transport provided.

ACCESS SERVICE TARIFF

SECTION 6. SWITCHED ACCESS SERVICE (Cont.)

6.2 Description of Switched Access Service Feature Groups (Cont.)

6.2.2 Feature Group B (FGB) (Cont.)

(A) Description (Cont.)

- (5) The access code for FGB switching is generally a uniform access code of the form 950-0XXX or 950-1XXX. One uniform access code will be assigned to the customer for the customer's domestic communications and another will be assigned to the customer for its international communications, if required. These uniform access codes will be the assigned access numbers of all FGB Switched Access Service provided to the customer by the telephone company.
- (6) When used in the terminating direction, FGB switching may be used to access valid NXXs in the LATA, time or weather announcement services of the telephone company, community information services of an information service provider and other customers' services (by dialing the appropriate digits). When directly routed to an end office, only those valid NXX codes served by that end office may be accessed. When routed through an access tandem, only those valid NXX codes served by end offices subtending the access tandem may be accessed.

The customer will also be billed additional non-access charges for calls to certain community information services for which rates are applicable under telephone company exchange service tariffs, e.g., 976 (DIAL-IT) Network Service. Additionally, non-access charges will also be billed for calls from a FGB trunk to another customer's service in accordance with that customer's applicable service rates when the telephone company performs the billing function for that customer.

Calls in the terminating direction will not be completed to 950-0XXX or 950-1XXX access codes, local operator assistance (0- and 0+), service codes (611 and 911) or 10XXX access codes. FGB may not be switched, in the terminating direction, to Switched Access Service Feature Groups B, C, and D.

- (7) The telephone company will establish a trunk group or groups for the customer at end office switches or access tandem switches where FGB switching is provided. When required by technical limitations, a separate trunk group will be established for each type of FGB switching arrangement provided. Different types of FGB or other switching arrangements may be combined in a single trunk group at the option of the telephone company.

ACCESS SERVICE TARIFF

SECTION 6. SWITCHED ACCESS SERVICE (Cont.)

6.2 Description of Switched Access Service Feature Groups (Cont.)

6.2.2 Feature Group B (FGB) (Cont.)

(A) Description (Cont.)

- (8) When all FGB switching arrangements are discontinued at an end office and/or in a LATA, an intercept announcement is provided. This arrangement provides, for a limited period of time, an announcement that the service associated with the number dialed has been disconnected.

6.2.3 Feature Group D (FGD)

(A) Description

- (1) FGD Access, which is available to all customers, provides trunk side access to Telephone Company end office switches. Special Access Services utilized for connection with FGD at Telephone Company designated WATS Serving offices as set forth in Section 7 following may be ordered separately by a customer other than the customer which orders the FGD Switched Access Service for the provision of WATS or WATS-type services. Special Access Services are ordered as set forth in 5.2 preceding. FGD access is applicable for all trunk side access other than access provided pursuant to 6.2.2, to telephone company switches regardless of whether FGD signaling is used.
- (2) FGD is provided at Telephone Company designated end office switches whether routed directly or via Telephone Company designated electronic access tandem switches. The Telephone Company will designate the first point(s) of switching for FGD services where the Telephone Company elects to provide equal access through a centralized equal access arrangement.
- (3) FGD is provided as trunk side switching through the use of end office or access tandem switch trunk equipment. The switch trunk equipment is provided with wink start start-pulsing signals and answer and disconnect supervisory signaling.
- (4) FGD switching is provided with multifrequency address signaling. Up to 12 digits of the called party number dialed by the customer's end user using dual tone multifrequency or dial pulse address signals will be provided by Telephone Company equipment to the customer's premises where the Switched Access Service terminates. Such address signals will be subject to the ordinary transmission capabilities of the Local Transport provided.

ACCESS SERVICE TARIFF

SECTION 6. SWITCHED ACCESS SERVICE (Cont.)

6.2 Description of Switched Access Service Feature Groups (Cont.)

6.2.3 Feature Group D (FGD) (Cont.)

(A) Description (Cont.)

- (5) FGD switching, when used in the terminating direction, may be used to access valid NXXs in the LATA, time or weather announcement services of the Telephone Company, community information services of an information service provider, and other customers' services (by dialing the appropriate codes) when such services can be reached using valid NXX codes. When directly routed to an end office, only those valid NXX codes served by that office may be accessed.

When routed through an access tandem, only those valid NXX codes served by end offices subtending the access tandem may be accessed. The customer will also be billed additional non-access charges for calls to certain community information services, for which rates are applicable under Telephone Company exchange service tariffs, e.g., 976 (DIAL-IT) Network Service. Additionally, non-access charges will also be billed for calls from a FGD trunk to another customer's service in accordance with that customer's applicable service rates when the Telephone Company performs the billing function for that customer. Calls in the terminating direction will not be completed to 950-1XXX or 950-0XXX access codes, local operator assistance (0- and 0+), Directory Assistance (411 and 555-1212), service codes 611 and 911 and 10XXX access codes. Calls will be completed to Directory Assistance (NPA-555-1212 or 555-1212) when FGD switching is combined with Directory Assistance switching. FGD may not be switched, in the terminating direction, to Switched Access Service Feature Groups B, C, or D.

- (6) The Telephone Company will establish a trunk group or groups for the customer at end office switches or access tandem switches where FGD switching is provided. When required by technical limitations, a separate trunk group will be established for each type of FGD switching arrangement provided. Different types of FGD or other switching arrangements may be combined in a single trunk group at the option of the Telephone Company.

ACCESS SERVICE TARIFF

SECTION 6. SWITCHED ACCESS SERVICE (Cont.)

6.2 Description of Switched Access Service Feature Groups (Cont.)

6.2.3 Feature Group D (FGD) (Cont.)

(A) Description (Cont.)

- (7) The access code for FGD switching is a uniform access code of the form 10XXX. A uniform access code(s) will be the assigned number of all FGD access provided to the customer by the Telephone Company. No access code is required for calls to a customer over FGD Switched Access Service if the end user's telephone exchange service is arranged for presubscription to that customer, as set forth in Section 9 following.
- (8) Where no access code is required, the number dialed by the customer's end user shall be a seven or ten digit number for calls in the North American Numbering Plan (NANP). For international calls outside the NANP, a seven to twelve digit number may be dialed. The form of the numbers dialed by the customer's end user is NXX-XXXX, 0 or 1 + NXX-XXXX, NPA + NXX-XXXX, 0 or 1 + NPA + NXX-XXXX, and, when the end office is equipped for International Direct Distance Dialing (IDDD), 01 + CC + NN or 011 + CC + NN.
- (9) When the 10XXX access code is used, FGD switching also provides for dialing the digit 0 for access to the customer's operator or the end-of-dialing digit (#) for cut-through access to the customer designated premises.
- (10) FGD switching will be arranged to accept calls from telephone exchange service locations without the need for dialing the 10XXX uniform access code. Each telephone exchange service line may be marked with a code to identify which 10XXX code its calls will be directed to for interLATA service.

ACCESS SERVICE TARIFF

SECTION 6. SWITCHED ACCESS SERVICE (Cont.)

6.2 Description of Switched Access Service Feature Groups (Cont.)

6.2.3 Feature Group D (FGD) (Cont.)

(B) Nonchargeable Options

- (1) When a customer has had FGB access in an end office and subsequently replaces the FGB access with FGD access, at the mutual agreement of the customer and the Telephone Company, the Telephone Company will direct calls dialed by the customer's end users using the customer's previous FGB access code to the customer's FGD access service. The customer must be prepared to handle normally dialed FGD calls, as well as calls dialed with the FGB access code which requires the customer to receive additional address signaling from the end user. Such calls will be rated as FGD. The Telephone Company may, with 90 days' written notice to the customer, discontinue this arrangement.

6.2.4 Toll Free Number Data Base Access Service

(A) General Description

Toll Free Number Data Base (Toll Free Number DB) Access Service is an originating service utilizing Trunk Side Access which provides for the forwarding of end user dialed toll free (i.e., 800-NXX-XXXX, 888-NXX-XXXX) calls to a customer based on the dialed Toll Free Number. The provision of Toll Free Number DB Service requires the customer's direct access to the Service Management System/Toll Free (SMS/SAC), or as an alternative, the provision of such service by a Responsible Organization.

When a Toll Free Number call is originated by an end user, the Telephone Company or a connecting Exchange Carrier will perform the customer identification function based on the dialed digits to determine the customer location to which the call is to be routed in accordance with SMS/Toll Free SAC information residing in the Telephone Company's or other Exchange Carrier's Service Control Point (SCP).

The customer has the option of having the dialed Toll Free Number (i.e., 800-NXX-XXXX, 888-NXX-XXX) or the translated Plain Old Telephone Service (POTS) number (i.e., NPA-NXX-XXXX) delivered. If the translated POTS number is delivered, the customer must request the POTS Translation vertical feature through the Responsible Organization as described in (B), following.

ACCESS SERVICE TARIFF

SECTION 6. SWITCHED ACCESS SERVICE (Cont.)

6.2 Description of Switched Access Service Feature Groups (Cont.)

6.2.4 Toll Free Number Data Base Access Service (Cont.)

(A) General Description (Cont.)

Toll Free Number DB Service provided from an equal access end office will be provisioned from the SSP switch as Feature Group D. Calls originating from end offices not equipped with equal access capabilities will be converted at the SSP switch to standard Feature Group D format.

The customer's Toll Free Number traffic may be combined in the same trunk group arrangement with the customer's non-Toll Free Number Access Service traffic or provisioned on a separate trunk group, unless prohibited by technical limitations.

Application of rates for Toll Free Number DB Service shall be as set forth in 6.6.8, following.

(B) Vertical Features

In addition to the basic carrier identification function, Toll Free Number service subscribers may request vertical features through a Responsible Organization. The POTS Translation feature is described in (1), and the Call Handling and Destination Features are described in (2), following.

(1) POTS Translation

The POTS Translation vertical feature provides the option of having the ten-digit POTS number (i.e., NPA-NXX-XXXX) delivered instead of the toll free dialed number (i.e., 800-NXX-XXXX, 888-NXX-XXXX) delivered to the service provider. Due to technical limitations, POTS Translation may not be available from all end offices.

A POTS Translation Charge as described in 6.6.8, following, is assessed to the service provider for each Toll Free Number DB call delivered.

ACCESS SERVICE TARIFF

SECTION 6. SWITCHED ACCESS SERVICE (Cont.)

6.2 Description of Switched Access Service Feature Groups (Cont.)

6.2.4 Toll Free Number Data Base Access Service (Cont.)

(B) Vertical Features (Cont.)

(2) Call Handling and Destination Features

Call Handling and Destination Features allow service subscribers variable routing options by specifying a single carrier, multiple carriers (Exchange and/or Interexchange Carriers), single terminations or multiple terminations. Multiple terminations require the POTS Translation feature described in (1), preceding. The following variable routing options are available.

- Routing by Originating NPA-NXX-XXXX
- Time of Day
- Day of Week
- Specific Date
- Allocation by Percentage

Routing by originating NPA-NXX-XXXX, where technically feasible, allows a service subscriber to specify one or more multiple terminations with a single carrier and/or multiple carriers (Exchange and/or Interexchange Carriers) based on where a call originates.

Time of Day/Day of Week allows a service subscriber to specify one or more multiple terminations with a single carrier and/or multiple carriers (Exchange and/or Interexchange Carriers) based on time of day or day of week the call originates.

Specific Date allows the service subscriber to specify alternate service routes with the date the call originates. These calls can be routed to one of multiple terminations, with a single carrier and/or multiple carriers (Exchange and/or Interexchange Carriers).

Allocation by Percentage allows the service subscriber to specify by percentage the calls to be allocated to multiple terminations and/or multiple carriers (Exchange and/or Interexchange Carriers).

A Call Handling and Destination Feature Query Charge as described in 6.6.8, following, is assessed to the service provider for each Toll Free Number query to the SCP which utilizes one or more of the Call Handling and Destination Features.

ACCESS SERVICE TARIFF

SECTION 6. SWITCHED ACCESS SERVICE (Cont.)

6.3 Transmission Specifications

Transmission Specifications for the Feature Groups are as set forth in Section 15 of the National Exchange Carrier Association Tariff F.C.C. No. 5.

6.4 Obligations of the Telephone Company

In addition to the obligations of the Telephone Company set forth in Section 2 preceding, the Telephone Company has certain other obligations pertaining only to the provision of Switched Access Service. These obligations are as follows:

6.4.1 Network Management

The Telephone Company will administer its network to ensure the provision of acceptable service levels to all telecommunications users of the Telephone Company's network services. Generally, service levels are considered acceptable only when both end users and customers are able to establish connections with little or no delay encountered within the Telephone Company network. The Telephone Company maintains the right to apply protective controls, i.e., those actions, such as call gapping, which selectively cancel the completion of traffic, over any traffic carried over its network, including that associated with a customer's Switched Access Service. Generally, such protective measures would only be taken as a result of occurrences such as failure or overload of Telephone Company or customer facilities, natural disasters, mass calling or national security demands. In the event that the protective controls applied by the Telephone Company result in the complete loss of service by the customer, the customer will be granted a Credit Allowance for Service Interruption as set forth in 2.4.3 preceding.

6.4.2 Design and Traffic Routing of Switched Access Service

For Feature Group D, the Telephone Company shall design and determine the routing of Switched Access Service, including the selection of the first point of switching, the selection of facilities from the interface to any switching point and to the end offices where busy hour minutes of capacity are ordered and the selection of tandem(s) for tandem routed traffic. The Telephone Company shall also decide if capacity is to be provided by originating only, terminating only, or two-way trunk groups. Finally, the Telephone Company will decide whether trunk side access will be provided through the use of 2-wire or 4-wire trunk terminating equipment. Selection of facilities and equipment and traffic routing of the service are based on standard engineering methods, available facilities and equipment, and the Telephone Company traffic routing plans. If the customer desires routing or directionality different from that determined by the Telephone Company, the Telephone Company will work cooperatively with the customer in determining (1) whether the service is to be routed directly to an end office or through an access tandem switch and (2) the directionality of the service.

ACCESS SERVICE TARIFF

SECTION 6. SWITCHED ACCESS SERVICE (Cont.)

6.4 Obligations of the Telephone Company (Cont.)

6.4.2 Design and Traffic Routing of Switched Access Service (Cont.)

The Telephone Company will designate the first point(s) of switching and routing to be used where equal access is provided through a centralized equal access arrangement.

For Feature Groups A, the line directionality and traffic routing of the Switched Access Service between the customer's premises and the entry switch are determined by the customer's order for service.

6.4.3 Provision of Service Performance Data

Subject to availability, end-to-end service performance data available to the Telephone Company through its own service evaluation routines may also be made available to the customer based on previously arranged intervals and format. These data provide information on overall end-to-end call completion and non-completion performance, e.g., customer equipment blockage, failure results and transmission performance. These data do not include service performance data which are provided under other tariff sections. If data are to be provided in other than paper format, the charges for such exchange will be determined on an individual case basis.

Subject to availability, the Telephone Company will make available trunk group data in the form of usage in CCS, peg count and overflow, to the customer based on previously agreed to intervals.

6.4.4 Determination of Number of Transmission Paths

For Feature Group A, which is ordered on a per line basis, the customer specifies the number of transmission paths in the order for service. The Telephone Company will determine the number of Switched Access Service transmission paths to be provided for the Switched Access Feature Group D busy hour minutes of capacity ordered. A transmission path is a communication path within the frequency bandwidth of approximately 300 to 3000 Hz. The number of transmission paths will be developed using the total busy hour minutes of capacity by type (as described in 6.1.1(E) preceding) for the end office. The total busy hour minutes of capacity by type for the end office will be converted to transmission paths using standard Telephone Company traffic engineering methods. For Feature Groups C and D, the design blocking objective based on BHMCs ordered will be no greater than one percent (.01) between the point of termination at the customer designated premise and the first point of switching when traffic is directly routed without an alternate route. Standard traffic engineering methods will be used by the Telephone Company to determine the number of transmission paths required to achieve this level of blocking.

ACCESS SERVICE TARIFF

SECTION 6. SWITCHED ACCESS SERVICE (Cont.)

6.5 Obligations of the Customer

In addition to the obligations of the customer set forth in Section 2 preceding, the customer has certain specific obligations pertaining to the use of Switched Access Service. These obligations are as follows:

6.5.1 Report Requirements

Customers are responsible for providing the following reports to the Telephone Company, when applicable.

Code Screening Reports

When a customer orders service class routing, trunk access limitation or call gapping arrangements, it must report the number of trunks and/or the appropriate codes to be instituted in each end office or access tandem switch, for each of the arrangements ordered.

6.5.2 Supervisory Signaling

The customer's facilities shall provide the necessary on-hook, off-hook, answer and disconnect supervision.

6.5.3 Trunk Group Measurement Reports

With the agreement of the customer, trunk group data in the form of usage in CCS, peg count and overflow for its end of all access trunk groups, where technologically feasible, will be made available to the Telephone Company. These data will be used to monitor trunk group utilization and service performance and will be based on previously arranged intervals and format.

ACCESS SERVICE TARIFF

SECTION 6. SWITCHED ACCESS SERVICE (Cont.)

6.5 Obligations of the Customer (cont'd)

6.5.4 Call Signaling

Depending on the signaling system used by the customer in its network, the customer's facilities shall transmit the following call signaling information to the Telephone Company on traffic the customer's end users originate which is handed off for termination on the Telephone Company's network.

(A) Signaling System 7 (SS7) Signaling

When the customer uses SS7 signaling, it will transmit the Calling Party Number (CPN) or, if different from the CPN, the Charge Number (CN) information in the SS7 signaling stream.

(B) Multi-Frequency (MF) Signaling

When the customer uses MF signaling, it will transmit the number of the calling party or, if different from the number of the calling party, the Charge Number (CN) information in the MF Automatic Number Identification (ANI) field.

(C) Internet Protocol (IP) Signaling

When the customer uses IP signaling, it will transmit the telephone number of the calling party or, if different from the telephone number, the billing number of the calling party.

6.6 Rate Regulations

This section contains the specific regulations governing the rates and charges that apply for Switched Access Service.

6.6.1 Description and Application of Rates and Charges

There are three types of rates and charges that apply to Switched Access Service. These are monthly recurring rates, usage rates and non-recurring charges. These rates and charges are applied differently to the various rate elements as set forth in (C) following.

ACCESS SERVICE TARIFF

SECTION 6. SWITCHED ACCESS SERVICE (Cont.)

6.6 Rate Regulations (Cont.)

6.6.1 Description and Application of Rates and Charges (Cont.)

(A) Usage Rates

Usage rates are rates that apply only when a specific rate element is used. These are applied on a per access minute or per Toll Free Number Data Base Query basis. Access minute charges are accumulated over a monthly period.

(B) Non-recurring Charges

Non-recurring charges are one-time charges that apply for a specific work activity (i.e., installation or change to an existing service). The types of non-recurring charges that apply for Switched Access Service are: installation of service and service rearrangements.

(1) Installation of Service

Non-recurring charges apply to each Switched Access Service installed. For FGA and FGB, the charge is applied per line or trunk, respectively. For FGD ordered on a busy hour minutes of capacity basis, the charge is applied on a per trunk basis but the charge applies only when the capacity ordered requires the installation of an additional trunk(s).

(2) Service Rearrangements

All changes to existing services other than changes involving administrative activities and the off-hook supervisory signaling of FGA Access Services, will be treated as a discontinuance of the existing service and an installation of a new service. The non-recurring charge described in (1) preceding will apply for this work activity. Moves that change the physical location of the point of termination are described and charged for as set forth in 6.6.4 following.

If, due to technical limitations of the Telephone Company, a customer could not combine its Toll Free Number Data Base traffic with its other trunk side Switched Access Services, no charge shall apply to combine these trunk groups when it becomes technically possible.

ACCESS SERVICE TARIFF

SECTION 6. SWITCHED ACCESS SERVICE (Cont.)

6.6 Rate Regulations (Cont.)

6.6.1 Description and Application of Rates and Charges (Cont.)

(B) Non-recurring Charges (Cont.)

(2) Service Rearrangements (Cont.)

Administrative changes will be made without charge(s) to the customer. Administrative changes are as follows:

- Change of customer name,
- Change of customer or customer's end user premises address when the change of address is not a result of a physical relocation of equipment,
- Change in billing date (name, address, or contact name or telephone number),
- Change of agency authorization,
- Change of customer circuit identification,
- Change of billing account number,
- Change of customer test line number,
- Change of customer or customer's end user contact name or telephone number, and
- Change of jurisdiction.

Changes to the point in time when the off-hook supervisory signal is provided in the originating call sequence i.e., when the off-hook supervisory signal is changed from being provided by the customer's equipment before the called party answers to being forwarded by the customer's equipment when the called party answers or vice versa, are subject to the nonrecurring charge as set forth in 5.2.2 preceding.

(C) Application of Rates

(1) Rates apply to:

- All FGA and FGB access minutes when utilized in the provision of MTS/WATS service.

ACCESS SERVICE TARIFF

SECTION 6. SWITCHED ACCESS SERVICE (Cont.)

6.6 Rate Regulations (Cont.)

6.6.1 Description and Application of Rates and Charges (Cont.)

(C) Application of Rates (Cont.)

(2) Where Feature Group A switched access usage is between a Primary Exchange Carrier and a Secondary Exchange Carrier within the same Extended Area Service calling area, and where the criteria specified in 2.4.6(B) are satisfied, the Secondary Exchange Carrier will apply switched Access Service Local Transport rates for its portion of the Local Transport facilities and end office rates to both originating and terminating access minutes, as set forth in Section 10 of this Tariff. This is in addition to those rates charged by the Primary Exchange Carrier. Such usage will be determined as set forth following:

- (a) Where end office specific usage data are available, such data will be used to determine the charges.
- (b) Where end office specific usage data are not available, the following method will be used to determine the applicable access minutes of use. The total originating and/or terminating usage will be the measured usage at the entry switch (i.e., dial tone office) or the assumed usage as set forth in 6.6.5 following.

Originating and/or terminating usage will then be apportioned between the Primary and Secondary Exchange Carriers in the following manner:

- For originating usage, develop ratios of the total number of subscriber lines in each secondary exchange to the total number of subscriber lines in the Primary Exchange Carrier's Extended Area Service area served by the access customer's dial tone office. Then apply these ratios to the total number of originating access minutes to determine access minutes for each secondary exchange.
- For terminating usage, develop ratios of the total number of subscriber lines in each secondary exchange to the total number of subscriber lines in the Primary Exchange Carrier's Extended Area Service area served by the dial tone office. Then apply these ratios to the total number of terminating access minutes to determine access minutes for each secondary exchange.

ACCESS SERVICE TARIFF

SECTION 6. SWITCHED ACCESS SERVICE (Cont.)

6.6 Rate Regulations (Cont.)

6.6.1 Description and Application of Rates and Charges (Cont.)

(C) Application of Rates (Cont.)

- In those instances where a Secondary Exchange Carrier's exchange is part of two or more Primary Exchange Carriers' Extended Area Service areas, the Secondary Exchange Carrier's subscriber line count described above must be apportioned between each Primary Exchange Carrier's Extended Area Service area. This apportionment will be based upon ratios of the subscriber line count of all exchanges other than the Secondary Exchange Carrier's in a Primary Exchange Carrier's Extended Area Service area, of which the Secondary Exchange Carrier's Exchange is part divided by the subscriber line count of all exchanges other than the Secondary Exchange Carrier's in all Primary Exchange Carrier Extended Area Service areas of which the Secondary Exchange Carrier's exchange is a part.

For purposes of administering this regulation, subscriber lines are defined as exchange service lines, Centrex Lines and Centrex-type lines provided by the telephone companies under local and/or general exchange service tariffs.

- (3) Where Feature Group B Switched Access usage is between a Primary Exchange Carrier access tandem office and a Secondary Exchange Carrier end office(s) that subtends the Feature Group B access tandem, and the criteria set forth in 2.4.6 are satisfied, the Secondary Exchange Carrier will apply Switched Access Service End Office Rates, as set forth in its Intrastate North Access Tariff. This is in addition to those rates charged by the Primary Exchange Carrier.

6.6.2 Minimum Periods

Switched Access Service is provided for a minimum period of one month.

ACCESS SERVICE TARIFF

SECTION 6. SWITCHED ACCESS SERVICE (Cont.)

6.6 Rate Regulations (Cont.)

6.6.3 Change of Feature Group Type

Changes from one type of Feature Group to another will be treated as a discontinuance of one type of service and a start of another. Nonrecurring charges will apply, and new minimum period obligations will be established.

6.6.4 Moves

A move involves a change in the physical location of one of the following:

- The point of termination at the customer designated premise
- The customer designated premise

The charges for the moves are dependent on whether the move is to a new location within the same building or to a different building.

(A) Moves Within the Same Building

When the move is to a new location within the same building, the charge for the move will be an amount equal to one half of the non-recurring charge for the capacity affected. There will be no change in the minimum period requirements.

(B) Moves to a Different Building

Moves to a different building will be treated as a discontinuance and start of service and all associated non-recurring charges will apply. New minimum period requirements will be established for the new service. The customer will also remain responsible for satisfying all outstanding minimum period charges for the discontinued service.

ACCESS SERVICE TARIFF

SECTION 6. SWITCHED ACCESS SERVICE (Cont.)

6.6 Rate Regulations (Cont.)

6.6.5 Measuring Access Minutes - Overview

Customer traffic to end offices will be measured (i.e., recorded or assumed) by the Telephone Company at end offices switches or access tandem switches. Originating and terminating calls will be measured (i.e., recorded or assumed) by the Telephone Company to determine the basis for computing chargeable access minutes. In the event the customer message detail is not available because the Telephone Company lost or damaged tapes or incurred recording system outages, the Telephone Company will estimate the volume of lost customer access minutes of use based on previously known values. For terminating calls over FGA, FGB, and FGD to Toll Free Number Service, and for originating calls over FGA (when the off-hook supervisory signal is provided by the customer's equipment before the called party answers), FGB, and FGD, the measured minutes are the chargeable access minutes.

6.6.6 Measuring Access Minutes

(A) Feature Group A Usage Measurement

For originating calls over FGA, usage measurement begins when the originating FGA entry switch receives an off-hook supervisory signal forwarded from the customer's point of termination. This off-hook signal may be provided by the customer's equipment before the called party answers, or forwarded by the customer's equipment when the called party answers.

The measurement of originating call usage over FGA ends when the originating FGA entry switch receives an on-hook supervisory signal from either the originating end user's end office, indicating the originating end user has disconnected, or the customer's point of termination, whichever is recognized first by the entry switch.

For terminating calls over FGA, usage measurement begins when the terminating FGA entry switch receives an off-hook supervisory signal from the terminating end user's end office, indicating the terminating end user has answered. The measurement of terminating call usage over FGA ends when the terminating FGA entry switch receives an on-hook supervisory signal from either the terminating end user's end office, indicating the terminating end user has disconnected, or the customer's point of termination, whichever is recognized first by the entry switch.

ACCESS SERVICE TARIFF

SECTION 6. SWITCHED ACCESS SERVICE (Cont.)

6.6 Rate Regulations (Cont.)

6.6.6 Measuring Access Minutes (Cont.)

(B) Feature Group B Usage Measurement

For originating calls over FGB, usage measurement begins when the originating FGB entry switch receives answer supervision forwarded from the customer's point of termination, indicating the customer's equipment has answered.

(C) Feature Group D Usage Measurement

For originating calls over FGD, usage measurement begins when the originating FGD entry switch receives the first wink supervisory signal forwarded from the customer's point of termination.

The measurement of originating call usage over FGD ends when the originating FGD entry switch receives disconnect supervision from either the originating end user's end office, indicating the originating end user has disconnected, or the customer's point of termination, whichever is recognized first by the entry switch.

For terminating calls over FGD, the measurement of access minutes begins when the terminating FGD entry switch receives answer supervision from the terminating end user's end office, indicating the terminating end user has answered.

The measurement of terminating call usage over FGD ends when the terminating FGD entry switch receives disconnect supervision from either the terminating end user's end office, indicating the terminating end user has disconnected, or the customer's point of termination, whichever is recognized first by the entry switch.

ACCESS SERVICE TARIFF

SECTION 6. SWITCHED ACCESS SERVICE (Cont.)

6.6 Rate Regulations (Cont.)

6.6.6.1 Network Blocking Charge for Feature Group D

The customer will be notified by the Telephone Company to increase its capacity (busy hour minutes of capacity or quantities of trunks) when excessive trunk group blocking occurs on groups carrying Feature Group D traffic and the measured access minutes for that hour exceed the capacity purchased. Excessive trunk group blocking occurs when the blocking thresholds stated below are exceeded. They are predicated on time-consistent, hourly measurements over a 30-day period excluding Saturdays, Sundays, and national holidays. If the order for additional capacity has not been received by the Telephone Company within 15 days of the notification, the Telephone Company will bill the customer, at the rate set forth in Section 10 of this Tariff, for each overflow in excess of the blocking threshold when (1) the average "30-day period" overflow exceeds the threshold level for any particular hour and (2) the "30-day period" measured average originating or two-way usage for the same clock hour exceeds the capacity purchased.

<u>Blocking Thresholds</u>		
<u>Trunks in Service</u>	<u>1%</u>	<u>1/2%</u>
1-2	.070	.045
3-4	.050	.035
5-6	.040	.025
7 or greater	.030	.020

The 1 percent blocking threshold is for transmission paths carrying traffic direct (without an alternate route) between an end office and a customer's premises. The 1/2 percent blocking threshold is for transmission paths carrying first routed traffic between an end office and a customer's premises via an access tandem.

ACCESS SERVICE TARIFF

SECTION 6. SWITCHED ACCESS SERVICE (Cont.)

6.6 Rate Regulations (Cont.)

6.6.7 Mileage Measurement

The mileage to be used to determine the monthly rate for the Local Transport is based on airline distance, using the V&H coordinates method. (This method is set forth in National Exchange Carrier Association Tariff F.C.C. No. 4.) Mileage between a remote office and an end office will be measured as separate segments and will be rated on a per minute of use per mile basis. #

When Direct Trunked Transport is ordered between the serving wire center and the end office, mileage is normally measured in one segment from the serving wire center to the end office. When Direct Trunked Transport is ordered between a serving wire center and a tandem and Tandem Switched Transport is ordered between the tandem and the end office, mileage is calculated separately for each segment.

6.6.8 Toll Free Number Data Base Access Service

800 Data Base Access Service is provided with FGC or FGD Switched Access Service. When a 1+800 series + NXX-XXXX call is originated by an end user, the Telephone Company will utilize the Signalling System 7 (SS7) network to query an 800 data base to perform the identification function. The call will then be routed to the identified customer over FGC or FGD switched access. The 800 series includes the following service area codes: 800, 888, 877, 866, 855, 844, 833 and 822.

The manner in which 800 data base access service is provided is dependent on the availability of SS7 service at the end office from which the service is provided.

Query charges as set forth in Section 10 of this Tariff are in addition to those charges applicable for the Feature Group C or Feature Group D switched access service.

6.7 Rates and Charges

"Rates can be found Section 10 of this Tariff."

If the Tandem Switched rates for the telephone company do not indicate "per segment" the rates will be applied based on a single segment measured from the serving wire center to the remote office.

ACCESS SERVICE TARIFF

SECTION 7. SPECIAL ACCESS SERVICE

7.1 General

Special Access Service provides a transmission path to directly connect customer designated premises or to connect a customer designated premise and a WATS Serving Office. Special Access Service includes all exchange access not utilizing end office switches.

7.1.1 Channel Types

There are several types of channels used to provide a customer with Special Access Services. Each type of channel is identified separately for purposes of ordering; however, such identification is not intended to limit a customer's use of the channel nor to imply that the channel is limited to a particular use. Each type of channel is described below:

Voice Grade - a channel for the transmission of analog signals within an approximate bandwidth of 300 to 3000 Hz. Voice grade service includes, among others, point-to-point services, and the provision of WATS access lines.

Digital Data - a channel for the digital transmission of synchronous serial data at rates of 2.4, 4.8, 9.6, or 56 Kbps.

High Capacity - a channel for the transmission of isochronous serial digital data at rates of 1.544 Mbps, 3.152, 6.312, 44.736, or 274.176.

7.1.2 Service Configurations

There are two types of service configurations over which Special Access Services are provided: two-point service and multipoint service.

(A) Two-Point Service

A two-point service connects two customer designated premises, either on a directly connected basis or through a hub where multiplexing functions are performed, or a customer designated premises and a WATS Serving Office (WSO).

Applicable rate elements are:

- Channel Terminations (one per customer designated premises)
- Channel Mileage (as applicable)
- Optional Features and Functions (when applicable)

- A Special Access Surcharge may be applicable.

ACCESS SERVICE TARIFF

SECTION 7. SPECIAL ACCESS SERVICE (Cont.)

7.1 General (Cont.)

7.1.2 Service Configurations (Cont.)

(B) Multipoint Service

Multipoint service connects three or more customer designated premises through one or more Telephone Company hubs.

When ordering, the customer will specify the desired bridging hub(s). Exchange Carrier Association Tariff F.C.C. No. 4 identifies serving wire centers, hub locations and the type of bridging functions available.

Applicable Rate Elements are:

- Channel Terminations (one per customer designated premises)
- Channel Mileage (as applicable between the serving wire center for each customer designated premises and the hub between hubs)
- Bridging
- Additional Optional Features and Functions (when applicable)

- A Special Access Surcharge may be applicable.

7.1.3 Rate Categories

There are three basic rate categories which apply to Special Access Service:

- Channel Termination (described in 7.1.3 (A) following)
- Channel Mileage (described in 7.1.3 (B) following)
- Optional Features and Functions (described in 7.1.3 (C) following)

(A) Channel Termination

The Channel Termination rate category recovers the costs associated with the communications path between a customer designated premises and the serving wire center of that premises. One Channel Termination charge applies per channel to the customer designated premises at which the channel is terminated.

ACCESS SERVICE TARIFF

SECTION 7. SPECIAL ACCESS SERVICE (Cont.)

7.1 General (Cont.)

7.1.3 Rate Categories (Cont.)

(B) Channel Mileage

The Channel Mileage rate category recovers the costs associated with the end office equipment and the transmission facilities between the serving wire centers. Channel Mileage rates are made up of the Channel Mileage Facility rate and the Channel Mileage Termination rate.

(1) Channel Mileage Facility

The Channel Mileage Facility rate recovers the per mile cost for the transmission path which extends between the Telephone Company Serving Wire Centers and/or Hubs.

(2) Channel Mileage Termination

The Channel Mileage Termination rate recovers the cost for end office equipment associated with terminating the facility (i.e., basic circuit equipment and terminations at serving wire centers and hubs). The Channel Mileage Termination rate will apply at the serving wire center(s) for each customer designated premises and Telephone Company hub where the channel is terminated.

(C) Optional Features and Functions

The optional features and functions rate category recovers the costs associated with optional features and functions which may be added to a Special Access Service to improve its quality or utility to meet specific communications requirements. These are not necessarily identifiable with specific facilities, but rather represent the end result in terms of performance characteristics which may be obtained by using various combinations of facilities. Although the facilities necessary to perform a specified function may be installed at various locations along the path of the service, they will be charged for as a single rate element.

7.1.4 Types of Rates and Charges

(A) Monthly Rates

Monthly rates are flat recurring rates that apply each month or fraction thereof that a Special Access Service is provided. For billing purposes, each month is considered to have 30 days.

ACCESS SERVICE TARIFF

SECTION 7. SPECIAL ACCESS SERVICE (Cont.)

7.1 General (Cont.)

7.1.4 Types of Rates and Charges (Cont.)

(B) Reserved for Future Use

(C) Nonrecurring Charges

Nonrecurring charges are one-time charges that apply for specific work activity.

(1) Installation of Service

Nonrecurring charges apply to each service installed.

(2) Installation of Optional Features and Functions

When optional features and functions are installed coincident with the initial installation of service, no separate nonrecurring charge is applicable. When optional features and functions are installed or changed subsequent to the installation of service, an Access Order Charge will apply per order.

(3) Service Rearrangements

Changes in the physical location of the point of termination or customer designated premises are moves as set forth in 7.3.2 following.

Changes in the type of Service will be treated as a discontinuance of the service and an installation of a new service.

ACCESS SERVICE TARIFF

SECTION 7. SPECIAL ACCESS SERVICE (Cont.)

7.1 General (Cont.)

7.1.4 Types of Rates and Charges (Cont.)

(C) Nonrecurring Charges (Cont.)

(3) Service Rearrangements (Cont.)

Changes in ownership or transfer of responsibility from one customer to another will be treated as a discontinuance of the service and an installation of a new service.

Administrative changes will be made without charge(s) to the customer. Administrative changes are as follows:

- Change of customer name,
- Change of customer or customer's end user premises address when the change of address is not a result of physical relocation of equipment,
- Change in billing data (name, address, or contact name or telephone number),
- Change of agency authorization,
- Change of customer circuit identification,
- Change of billing account number,
- Change of customer test line number,
- Change of customer or customer's end user contact name or telephone number, and
- Change of jurisdiction

All other service rearrangements will be charged as follows:

- If the change involves the addition of other customer designated premises to an existing service, the nonrecurring charge for the channel termination rate element will apply. The charge(s) will apply only for the location(s) that is being added. The charges will be in addition to an Access Order Charge.
- If the change involves the addition of an optional feature or function, or if the change involves changing the type of signaling, the Access Order Charge will apply.

ACCESS SERVICE TARIFF

SECTION 7. SPECIAL ACCESS SERVICE (Cont.)

7.1 General (Cont.)

7.1.5 Design Layout Report

At the request of the customer, the Telephone Company will provide to the customer the make-up of the facilities and services provided under this Tariff as Special Access Service to aid the customer in designing its overall service. This information will be provided in the form of a Design Layout Report. The Design Layout Report will be provided to the customer at no charge, and will be reissued or updated whenever these facilities are materially changed.

7.1.6 Acceptance Testing

At no additional charge, the Telephone Company will, at the customer's request, cooperatively test Special Access Service at the time of installation.

7.1.7 Ordering Options and Conditions

Special Access Service is ordered under the Access Order provisions set forth in Section 5 preceding.

7.2 Service Descriptions

7.2.1 Voice Grade Service

(A) Basic Channel Description

A Voice Grade Channel is a channel which provides voice frequency transmission capability in the nominal frequency range of 300 to 3000 Hz and may be terminated 2-wire or 4-wire. Voice Grade Channels are provided between customer designated premises or between a customer premises and a Telephone Company Hub, which may be located in another exchange carrier's territory.

(B) Technical Specifications

Technical Specifications for Voice Grade Service will be in accordance with standard industry procedures.

ACCESS SERVICE TARIFF

SECTION 7. SPECIAL ACCESS SERVICE (Cont.)

7.2 Service Descriptions (Cont.)

7.2.1 Voice Grade Service (Cont.)

(C) Optional Features and Functions

(1) Central Office Bridging Capability

- (a) Voice Bridging (two-wire and four-wire)
- (b) Data Bridging (two-wire and four-wire)
- (c) Telemetry and Alarm Bridging

(2) Conditioning

Conditioning provides more specific transmission characteristics for Voice Grade services.

(a) C-Type Conditioning

C-Type Conditioning is provided for the additional control of attenuation distortion and envelope delay distortion on data services.

(b) Data Capability (D Conditioning)

Data Capability provides transmission characteristics suitable for data communications. Specifically, Data Capability provides for the control of Signal to C-Notched Noise Ratio and intermodulation distortion.

(3) Customer Specified Premises Receive Level

This option allows the customer to specify the receive level at the Point of Termination. The level must be within a specific range on effective four-wire transmission.

ACCESS SERVICE TARIFF

SECTION 7. SPECIAL ACCESS SERVICE (Cont.)

7.2 Service Descriptions (Cont.)

7.2.1 Voice Grade Service (Cont.)

(C) Optional Features and Functions (Cont.)

(4) Improved Return Loss

- (a) On Effective Four-Wire Transmission at Four-Wire Point of Termination (applicable to each two-wire port) improved return loss provides for a fixed 600 ohm impedance, variable level range and simplex reversal.
- (b) On Effective Two-Wire Transmission at Two-Wire Point of Termination improved return loss provides for more stringent Echo Control specifications.

(5) Signaling Capability

Signaling Capability provides for the ability to transmit signals from one customer premises to another customer premises on the same service. The signaling capability charge will not apply when used in the provision of WATS access service.

(6) Selective Signaling Arrangement

An arrangement that permits code selective ringing for up to ten codes on a multipoint service.

(7) Transfer Arrangement

An arrangement that affords the customer an additional measure of flexibility in the use of an access channel(s). The arrangement can be utilized to transfer a leg of a Special Access Service to another channel that terminates in either the same or a different customer premises.

(8) Public Packet Switching Network (PPSN) Interface Arrangement

An arrangement that provides the interface requirements that permit a Voice Grade service to interface with a Public Packet Switching Network packet switch located in a Telephone Company premises.

ACCESS SERVICE TARIFF

SECTION 7. SPECIAL ACCESS SERVICE (Cont.)

7.2 Service Descriptions (Cont.)

7.2.1 Voice Grade Service (Cont.)

(C) Optional Features and Functions (Cont.)

(9) Four-Wire/Two-Wire Conversions

When a customer requests that an effective four-wire channel be terminated with a two-wire channel interface at the customer designated premises, a four-wire to two-wire conversion is required.

7.2.2 Digital Data Service

(A) Basic Channel Description

A Digital Data channel is a channel for duplex four-wire transmission of synchronous serial data at the rate of 2.4, 4.8, 9.6, or 56 Kbps. The actual bit rate is a function of the channel interface selected by the customer. The channel provides a synchronous service with timing provided by the Telephone Company through the Telephone Company's facilities to the customer in the received bit stream. Digital Data channels are only available from wire centers equipped for digital transmission. This service is subject to the technical limitations of the Central office equipment used by the Company.

(B) Technical Specifications and Network Channel Interfaces

Technical Specifications for Digital Data Service will be in accordance with standard industry procedures.

The following network channel interfaces (NCIs) define the bit rates that are available for a Digital Data channel:

<u>NCI</u>	<u>Bit Rate</u>
DU-24	2.4 Kbps
DU-48	4.8 Kbps
DU-96	9.6 Kbps
DU-56	56.0 Kbps

ACCESS SERVICE TARIFF

SECTION 7. SPECIAL ACCESS SERVICE (Cont.)

7.2 Service Descriptions (Cont.)

7.2.2 Digital Data Service (Cont.)

(C) Optional Features and Functions

(1) Central Office Bridging Capability

The bridging functions performed are to connect three or more customer designated premises in a multipoint arrangement.

(2) DSO to Subrate

An arrangement that converts a DSO-B 64.0 kbps channel to subspeeds of up to twenty 2.4 kbps, ten 4.8 kbps or five 9.6 kbps DSO-A channels using digital time division multiplexing.

(3) Secondary Channel Capability

The secondary channel option provides the customer with the capability to derive an independent, slower speed auxiliary (secondary) channel that operates in parallel with a primary Digital Data Channel. It is available for all speeds of 2.4, 4.8, 9.6, and 56 kbps channels. For 56 kbps channels, the option may be used only in two-point configurations which do not require the installation of loop repeater equipment. The technical parameters for the channels with a secondary channel option are set forth in Technical Publication - PUB 62310. The speeds of the secondary channels are as follows:

133 bps with a primary 2.4 kbps channel
266 bps with a primary 4.8 kbps channel
533 bps with a primary 9.6 kbps channel
2,666 bps with a primary 56 kbps channel

This option feature is subject to availability.

(4) Transfer Arrangement

An arrangement that affords the customer an additional measure of protection and/or flexibility in the use of their access channel(s). The arrangement can be utilized to transfer a leg of a Special Access Service to either a spare or working channel that terminates in either the same or a different customer designated premises. This arrangement is only available at a Telephone Company designated hub. A key activated or dial-up control service is required to operate the transfer arrangement. A spare channel, if required, is not included as a part of the option.

ACCESS SERVICE TARIFF

SECTION 7. SPECIAL ACCESS SERVICE (Cont.)

7.2 Service Descriptions (Cont.)

7.2.3 High Capacity Service

(A) Basic Channel Description

A High Capacity Channel is a channel for the transmission of 384 Kbps, 768 Kbps, or 1.544 Mbps isochronous serial data. The actual bit rate is a function of the channel interface selected by the customer.

(B) Technical Specifications and Network Channel Interfaces

Technical Specifications for High Capacity Service will be in accordance with standard industry procedures.

The following network channel interfaces (NCIs) define the bit rates that are available for a High Capacity channel:

<u>NCI</u>	<u>Bit Rate</u>
DS-15	1.544 Mbps (DS1)
DS-44	44.736 Mbps (DS3)

(C) Optional Features and Functions

(1) Automatic Loop Transfer

The Automatic Loop Transfer provides protection against failure of the facilities between a customer designated premises and the wire center serving that premises. Protection is furnished through the use of a switching arrangement that automatically switches to a spare channel line when a working line fails.

(2) Transfer Arrangement

An arrangement that affords the customer an additional measure of flexibility in the use of their access channel(s). The arrangement can be utilized to transfer a leg of a Special Access Service to either a spare or working channel that terminates in either the same or a different customer designated premises.

ACCESS SERVICE TARIFF

SECTION 7. SPECIAL ACCESS SERVICE (Cont.)

7.2 Service Descriptions (Cont.)

7.2.3 High Capacity Service (Cont.)

(C) Optional Features and Functions (Cont.)

(3) Central Office Multiplexing

(a) DS1 to Voice

An arrangement that converts a 1.544 Mbps channel to 24 channels for use with Voice Grade Services.

(b) DS3 to DS1

An arrangement that converts a 44.736 Mbps channel to 28 DS1 channels using digital time division multiplexing.

7.2.4 Surcharge for Special Access Service

7.2.4.1 Application

(A) Special access service provided under this Tariff may be subject to the monthly Special Access Surcharge as set forth in Section 7.4.1(D).

(B) The Special Access Surcharge will apply to each Intrastate Special Access Service that terminates on an end user's PBX or other device where, through a function of the device, the Special Access Service interconnects to the local exchange network. Interconnection functions include but are not limited to wiring and software functions, bridging, switching or patching of calls or stations.

ACCESS SERVICE TARIFF

SECTION 7. SPECIAL ACCESS SERVICE (Cont.)

7.2 Service Descriptions (Cont.)

7.2.4 Surcharge for Special Access Service (Cont.)

7.2.4.1 Application (Cont.)

- (C) Special Access Service will be exempted from the Surcharge by the Telephone Company upon receipt of the customer's written certification for the following Special Access Service terminations:
- (1) an open-end termination in a Telephone Company switch of an FX line, including CCSA and CCSA-equivalent ONALs; or
 - (2) an analog channel termination that is used for radio or television programming; or
 - (3) a termination used for TELEX service; or
 - (4) a termination that by the nature of its operating characteristics could not make use of Telephone Company common lines such as terminations which are restricted through hardware or software; or
 - (5) a termination that interconnects either directly or indirectly to the local exchange network where the usage is subject to Carrier Common Line charges such as, where the Special Access Service accesses only FGA and no local exchange lines, or Special Access Service between customer points of termination, or Special Access connecting CCSA or CCSA-type equipment (inter-machine trunks); or
 - (6) a termination that the customer certifies to the Telephone Company is not connected to a PBX or other device capable of inter-connecting the Special Access Service to a local exchange subscriber line.

ACCESS SERVICE TARIFF

SECTION 7. SPECIAL ACCESS SERVICE (Cont.)

7.2 Service Descriptions (Cont.)

7.2.4 Surcharge for Special Access Service (Cont.)

7.2.4.2 Exemption of Special Access Service

- (A) Special Access Services which are terminated as set forth in 7.2.4.1 preceding will be exempted from the Special Access Surcharge if the customer provides the Telephone Company with written exemption certification. The certification may be provided to the Telephone Company (1) at the time the Special Access Service is ordered or installed; (2) at such time as the service is reterminated to a device incapable of interconnection to local exchange facilities, or (3) at such time as the service becomes associated with a Switched Access Service that is subject to Carrier Common Line Charges.
- (B) The exemption certification is to be provided by the customer ordering the service. The certification must be signed by the customer or authorized representative and include the category of exemption, as set forth in 7.2.4.1 preceding for each termination, and the date which the exemption is effective.
- (C) The customer shall also notify the Telephone Company when an exempted Special Access Service is changed or reterminated such that the exemption is no longer applicable.
- (D) The Telephone Company will work cooperatively with the customer to resolve any questions regarding the exemption certification. However, the Telephone Company reserves the right to request additional information from the customer, when necessary, to assure qualifications for exemption of the Surcharge are met. In addition, the Telephone Company may withhold exemption of the service until the dispute is resolved.

ACCESS SERVICE TARIFF

SECTION 7. SPECIAL ACCESS SERVICE (Cont.)

7.3 Rate Regulations

This section contains the specific regulations governing the rates and charges that apply for Special Access Service.

7.3.1 Minimum Periods

Special Access Services except for Program Audio and Video, are provided for a minimum period of one month. Program Audio and Video are provided for a minimum period of 24 hours.

7.3.2 Moves

A move involves a change in the physical location of either a point of termination at a customer premises or a customer's premises.

(A) Moves Within the Same Building

When the move is to a new location within the same building, there will be no change in the minimum period requirements.

(B) Moves to a Different Building

Moves to a different building will be treated as a discontinuance and start of service. New minimum period requirements will be established for the new services. The customer will also remain responsible for satisfying all outstanding minimum period charges for the discontinued service.

7.3.3 Mileage Measurement

The mileage to be used to determine the monthly rate for the Channel Mileage is calculated on the airline distance between the locations involved, i.e., serving wire center of a customer designated premise to a serving wire center of a customer designated premise or between the serving wire center associated with a customer designated premise and a WATS Serving Office.

To determine the rate to be billed, first compute the mileage using the V&H coordinates method, as set forth in the National Exchange Carrier Association Tariff F.C.C. No. 4. This mileage is multiplied by the rate per channel mile shown in the Telephone Company's General Exchange Tariff as filed with the North Dakota Public Utilities Commission to compute the monthly channel mileage charge.

ACCESS SERVICE TARIFF

SECTION 7. SPECIAL ACCESS SERVICE (Cont.)

7.3 Rate Regulations (Cont.)

7.3.4 Special Access Surcharge

- (A) The Surcharge applies to each channel of a Special Access Service and per voice grade equivalent service derived from a Special Access Service as shown in the following example:

<u>Special Access Service</u>	<u>Voice Grade Equivalent</u>		<u>Surcharge</u>	<u>Monthly Charge</u>
DS1	24	X	\$25	= \$600

One Surcharge will apply for each termination of a multipoint Special Access Service at a customer's designated premises.

- (B) The Telephone Company will bill the appropriate Special Access Surcharge to the ordering customer for each Intrastate Special Access Service installed unless exemption certification is provided as set forth in 7.2.4.2 preceding.
- (C) If written certification is not received at the time the Special Access Service is obtained, the Surcharge will be applied. Exempt status will become effective on the certification date indicated by the customer, subject to the regulations set forth in (D) following.
- (D) Crediting the Surcharge

The Telephone Company will cease billing the Special Access Surcharge when certification, as set forth in 7.2.4.2 preceding, is received. If the status of the Special Access Service was changed prior to receipt of the exemption certification, the Telephone Company will credit the customer's account, not to exceed ninety (90) days, based on the effective date of the change as specified by the customer in the letter of certification.

7.4 Rates and Charges

Rates can be found in Section 10 of this Tariff.

ACCESS SERVICE TARIFF

SECTION 7. SPECIAL ACCESS SERVICE (Cont.)

Reserved for Future Use

ACCESS SERVICE TARIFF

SECTION 7. SPECIAL ACCESS SERVICE (Cont.)

Reserved for Future Use

ACCESS SERVICE TARIFF

SECTION 7. SPECIAL ACCESS SERVICE (Cont.)

Reserved for Future Use

ACCESS SERVICE TARIFF

SECTION 8. RESERVED FOR FUTURE USE

ACCESS SERVICE TARIFF

SECTION 8. RESERVED FOR FUTURE USE

ACCESS SERVICE TARIFF

SECTION 8. RESERVED FOR FUTURE USE

ACCESS SERVICE TARIFF

SECTION 8. RESERVED FOR FUTURE USE

ACCESS SERVICE TARIFF

SECTION 8. RESERVED FOR FUTURE USE

ACCESS SERVICE TARIFF

SECTION 9. MISCELLANEOUS SERVICES

9.1 IntraLATA Presubscription

IntraLATA Presubscription is the process by which end user customers may select and designate to the Telephone Company a carrier to access without an access code, for intraLATA usage calls. This carrier is referred to as the end user's predesignated intraLATA Carrier.

- (A) New end users who are served by end offices equipped with Feature Group D will be asked to presubscribe to an intraLATA Carrier at the time they place an order with the Telephone Company for Telephone Exchange Service. They may select either of the following options. There will be no charge for this initial selection.

- designate a primary intraLATA Carrier for all of its lines,
- designate a different intraLATA Carrier for each of its lines.

Only one intraLATA Carrier may be selected for each individual line, or lines terminating in the same hunt group. Subsequent to the installation of Telephone Exchange Service and after the end user's initial selection of a predesignated intraLATA Carrier, for any change in selection, a nonrecurring charge, as set forth in Section 10 of this Tariff, applies.

- (B) If the new end user fails to designate an intraLATA Carrier as its predesignated intraLATA Carrier prior to the date of installation of Telephone Exchange Service, the Telephone Company will (1) require the end user to dial an access code (10XXX) for all interstate calls, or (2) block the end user from interstate calling. The end user will be notified which option will be applied if they fail to presubscribe to an intraLATA Carrier. Blocked end user may designate another, or initial, intraLATA Carrier as its predesignated intraLATA Carrier one time at no charge, if it is requested within six months after the installation of Telephone Exchange Service.

For any change in selection after 6 months from the installation of Telephone Exchange Service, a nonrecurring charge, as set forth in Section 10 of this Tariff applies. Presubscription Charges per the Telephone Companies Interstate access tariff and IntraLATA Presubscription Charges, as set forth in the Independent Telephone Company's North Dakota P.S.C. Price Schedule No. 2 apply when the subscriber simultaneously changes the carrier(s) selected for IntraLATA and InterLATA usage calls.

- (C) If an intraLATA Carrier elects to discontinue its Feature Group D Service, the intraLATA Carrier will notify the Telephone Company of the cancellation. The intraLATA Carrier will also notify all end users which selected them that they are cancelling their service and that they should contact the Telephone Company to select a new primary intraLATA Carrier. The intraLATA Carrier will also inform the end user that it will pay the presubscription change charge. The canceling intraLATA Carrier will then be billed by the Telephone Company the appropriate charge for each end user.

ACCESS SERVICE TARIFF

SECTION 9. MISCELLANEOUS SERVICES (Cont.)

9.2 Unauthorized PIC Change

If an intraLATA Carrier requests a PIC change on behalf of a billed party (e.g., an end user or the designator of the PIC for a pay telephone), and the billed party subsequently denies requesting the change, and the intraLATA Carrier is unable to substantiate the change with a letter of agency signed by the billed party; then:

- The billed party will be reassigned to their previously selected intraLATA Carrier. No charge will apply to the billed party for this reassignment.
- The Unauthorized Presubscription Change Charge as set forth in Section 10 of this Tariff will apply to the intraLATA Carrier that requested the unauthorized PIC change. This charge is applied in addition to the Presubscription Charge set forth Section 10 of this Tariff.

9.3 Reserved for Future Use

9.4 Billing Name and Address Service

- Billing Name and Address (BNA) Service is the provision by the Telephone Company to an Intrastate service provider who is a customer of the Telephone Company of the complete billing name, street address, city or town, state and zip code for a telephone number or calling card account number assigned by the Telephone Company.
- The Telephone Company, upon request, will provide Billing Name and Address (BNA) service. The BNA will be provided only for the purpose of billing for calling card, third party, or collect calls or to bill a call when the originating telephone number is provided. BNA will be provided for telephone numbers with published status. Requests for BNA information associated with nonpublished and unlisted telephone numbers will be provided, unless the subscriber to a nonpublished or unlisted telephone number has affirmatively requested that its BNA not be disclosed.
- A standard format for the receipt and provision of telephone number and billing name and address information will be established by the Telephone Company and provided to the customer. If in the course of Telephone Company business it is necessary to change the format, the Telephone Company will provide notification to the involved customers one month prior to the change. The Telephone Company will specify the location where requests are to be received.

ACCESS SERVICE TARIFF

SECTION 9. MISCELLANEOUS SERVICES (Cont.)

9.4 Billing Name and Address Service (Cont.)

-

- (A) The BNA output records will be sent to the customer via first class U.S. Mail. The output records will normally be made available for mailing ten workdays after receipt of the customer's order or at an interval mutually agreed upon. Availability may be delayed in case of input errors in the customer provided order.
- (B) Any customer provided BNA pursuant to this tariff agrees to abide by all applicable rules, decisions, orders, statutes, and laws concerning the disclosure of published telephone numbers, and further agrees to use the information contained therein only for the purpose of billing for services provided to their end users.

9.5 Additional Engineering

Additional Engineering will be undertaken only after the Telephone Company has notified the customer that additional engineering charges apply as set forth in the Independent Telephone Company's North Dakota P.S.C. Price Schedule No. 2 following, and the customer agrees to such charges.

Additional Engineering will be provided by the Telephone Company at the request of the customer only when:

- (A) A customer requests additional technical information after the Telephone Company has already provided the technical information normally included on the Design Layout Report (DLR) as set forth in Section 7.1.5 preceding.
- (B) Additional Engineering time is incurred by the Telephone Company to engineer a customer's request for a customized service as set forth in Section 7 preceding.
- (C) A customer requested Design Change requires the expenditure of Additional Engineering time. The charge for additional engineering time relating to the engineering review, which is undertaken to determine if a design change is indeed required, will apply whether or not the customer authorizes the Telephone Company to proceed with the Design Change.

ACCESS SERVICE TARIFF

SECTION 9. MISCELLANEOUS SERVICES (Cont.)

9.6 Additional Labor

Additional Labor is that labor requested by the customer on a given service and agreed to by the Telephone Company as set forth in 9.6.1 through 9.6.5 following. The Telephone Company will notify the customer that Additional Labor charges as set forth in the Independent Telephone Company's North Dakota P.S.C. Price Schedule No. 2 following will apply before any additional labor is undertaken. A call-out of a Telephone Company employee at a time not consecutive with the employee's scheduled work period is subject to a minimum charge of four hours. When provisioning or restoring Telecommunications Service Priority services, the Telephone Company will, when possible, notify the customer of the applicability of these Additional Labor charges.

9.6.1 Overtime Installation

Overtime installation is that Telephone Company installation effort outside of normally scheduled working hours.

9.6.2 Overtime Repair

Overtime repair is that Telephone Company effort performed outside of normally scheduled working hours.

9.6.3 Standby

Standby includes all time in excess of one-half (1/2) hour during which Telephone Company personnel standby to make installation acceptance tests or cooperative tests with a customer to verify facility repair on a given service.

9.6.4 Testing and Maintenance with Other Telephone Companies

Additional testing, maintenance or repair of facilities which connect other telephone companies is that which is in addition to the normal effort required to test, maintain or repair facilities provided solely by the Telephone Company.

9.6.5 Other Labor

Other labor is that additional labor not included in 9.6.1 through 9.6.4 preceding and labor incurred to accommodate a specific customer request that involves only labor which is not covered by any other section of this tariff.

ACCESS SERVICE TARIFF

SECTION 9. MISCELLANEOUS SERVICES (Cont.)

Reserved For Future Use

ACCESS SERVICE TARIFF

SECTION 9. MISCELLANEOUS SERVICES (Cont.)

Reserved For Future Use

ACCESS SERVICE TARIFF

SECTION 9. MISCELLANEOUS SERVICES (Cont.)

Reserved For Future Use

ACCESS SERVICE TARIFF

SECTION 9. MISCELLANEOUS SERVICES (Cont.)

Reserved For Future Use

ACCESS SERVICE TARIFF

SECTION 9. MISCELLANEOUS SERVICES (Cont.)

Reserved For Future Use

ACCESS SERVICE

10. Rates and Charges

End User Access Service

	<u>Rates</u>
(A) <u>Carrier Common Line Access Service Rate#</u>	
Premium Access Per Mou	
– Originating Rate Equal to	\$.015
– Terminating Rate Equal to	\$.000
(B) <u>End User Common Line (EUCL) - Business</u>	
Multi-line – per individual line or trunk ⁽¹⁾	\$ NA
ISDN-BRI subscriber – per state per facility	NA
Centrex CO – per individual line or trunk	NA
Single line – per individual line or trunk	NA
(C) <u>End User Common Line (EUCL) – Residence</u>	
Primary Residence – per individual line or trunk	\$ NA
Non-Primary Residence – per individual line or trunk	\$ NA

#See page 149 for VoIP – PSTN rates.

⁽¹⁾ For ISDN-PRI and T-1 CAS Service multiply the EUCL rate times five for each T-1 facility.

ACCESS SERVICE

10. Rates and Charges (Cont.)

End User Access Service (Cont.)

	<u>Monthly Rates</u>
(D) <u>PICC</u>	
Residence Subscriber	
– Primary, per individual line or trunk	\$ 0.00
– Non-Primary, per individual line or trunk	\$ 0.00
Single Line Business Subscriber, Per individual line or trunk	\$ 0.00
Multi-line Business Subscriber, Per individual line or trunk	\$ 0.00
ISDN-BRI Subscriber, Per facility	\$ 0.00
ISDN-PRI Subscriber, Per T-1 facility	\$ 0.00
Centrex Subscriber, Per individual station line	\$ 0.00

ACCESS SERVICE

10. Rates and Charges (Cont.)

Local Transport

(A) Direct Trunked Transport

	<u>Rate</u>
(1) <u>Direct Trunked Facility</u>	
Per Mile	
–Voice Grade	NA
–High Capacity DS1	\$ 19.34
–High Capacity DS3	ICB
(2) <u>Direct Trunked Termination</u>	
Per Termination	
–Voice Grade	NA
–High Capacity DS1	\$ 94.34
–High Capacity DS3	ICB
(B) <u>Multiplexing</u>	
Per Arrangement	
DS1 to Voice	\$ 183.12
DS3 to DS1	ICB
(C) <u>Tandem Switched Transport#</u>	
(1) Tandem Switched Facility	
Per Access MOU Per Mile	
Originating	\$.000402
Terminating	.000402
(2) Tandem Switch Termination	
Per Access MOU Per Termination	
Originating	\$.002090
Terminating	.002090
(3) Tandem Switching Charge	\$.005272

#See page 149 for VoIP – PSTN rates.

ACCESS SERVICE

10. Rates and Charges (Cont.)

Local Transport (Cont.)

	<u>Rate</u>
(D) <u>Entrance Facilities</u>	
Per Termination	
–Voice Grade Two-Wire	NA
–Voice Grade Four-Wire	NA
–High Capacity DS1	\$ 178.63
–High Capacity DS3	ICB
(E) <u>Transport Interconnection Charge</u>	
Per Access MOU	\$ 0
(F) <u>Installation Non-Recurring Charge</u>	
(1) Per 24 trunks activated or fraction thereof on a per order basis	\$ 310.00
(2) Interim NXX Translations per Order -per LATA on Market Area	\$ 136.00
(3) Per Entrance Facility	
Voice Grade 2-Wire	NA
Voice Grade 4-Wire	NA
High Capacity DS1	\$ 251.00
High Capacity DS3	ICB
	<u>Rate Per</u>
	<u>Call Blocked</u>
(G) <u>Network Blocking Charge</u>	
(Applies to FGD)	\$.0153

ACCESS SERVICE

10. Rates and Charges (Cont.)

End Office

	<u>Rate#</u>
(A) <u>Local Switching</u>	
(1) <u>Premium</u>	
Per Access Minute	
Originating	\$.044902
Terminating	.044902
(B) <u>Information Surcharge</u>	
(1) <u>Premium</u>	
Per Access Minute Per 100	
Access Minutes	
Originating	\$.0494
Terminating	.0494
(C) <u>Toll Free Number Data Base Service</u>	<u>Rates Per</u>
	<u>Call/Query</u>
Per Query	
– Basic	\$.0053
– Vertical Feature	\$.0059

#See page 149 for VoIP – PSTN rates

ACCESS SERVICE

10. Rates and Charges (Cont.)

Special Access Service #

	<u>Monthly Rates</u>	<u>Non Recurring Charges</u>
(A) <u>Voice Grade Channel</u>		
(1) <u>Channel Termination</u> Per Termination*		
–Two-Wire	ICB	ICB
–Four-Wire	ICB	ICB
(2) <u>Channel Mileage Facility</u> Per Mile	ICB	NA
(3) <u>Channel Mileage</u> <u>Termination</u> Per Termination	ICB	NA
(4) <u>Optional Features and</u> <u>Functions</u>		
(a) <u>Bridging</u>		
Voice Bridging Per Port		
–Two-Wire	ICB	NA
–Four-Wire	ICB	NA
Data Bridging Per Port		
–Two-Wire	ICB	NA
–Four-Wire	ICB	NA
(b) <u>Conditioning Per</u> <u>Termination</u>		
–C-Type	ICB	
–Improved Attenuation Distortion*	NA	NA
–Improved Envelope Delay Distortion	NA	NA
–Data Capability	ICB	NA
–Telephoto Capability	ICB	NA

* The Channel Termination rate includes non-chargeable Channel Interface as set forth in Section 7.1.4, preceding.

Rates and charges for other special access services, optional features, or bit rates are ICB.

ACCESS SERVICE

10. Rates and Charges (Cont.)

Special Access Service (Cont.) #

	<u>Monthly Rates</u>	<u>Non Recurring Charges</u>
(4) <u>Optional Features and Functions (Cont.)</u>		
(c) Improved Return Loss for Effective Two-Wire or Four-Wire Transmission Per Termination		
–Two-Wire	ICB	NA
–Four-Wire	ICB	NA
(d) Customer Specified Receive Level per Two-Wire Termination	ICB	NA
(e) Signaling Capability Per Termination	ICB	NA
(f) Selective Signaling Arrangement Per Arrangement	ICB	NA

Rates and charges for other special access services, optional features, or bit rates are ICB.

ACCESS SERVICE

10. Rates and Charges (Cont.)

Special Access Service (Cont.) #

	<u>Monthly Rates</u>	<u>Non Recurring Charges</u>
(B) <u>Metallic Channel</u>		
(1) <u>Channel Termination</u> Per Termination* Two Wire	NA	NA
(2) <u>Channel Mileage Facility</u> Per Mile	NA	NA
(3) <u>Channel Mileage</u> <u>Termination</u> Per Termination	NA	NA
(C) <u>Digital Data</u>		
(1) <u>Channel Termination</u> Per Termination* 56-64Kbps	ICB	ICB
(2) <u>Channel Mileage Facility</u> Per Mile 56-64Kbps	ICB	NA
(3) <u>Channel Mileage</u> <u>Termination</u> Per Termination 56-64 Kbps	ICB	NA

* The Channel Termination rate includes non-chargeable Channel Interface as set forth in Section 7.1.4, preceding.

Rates and charges for other special access services, optional features, or bit rates are ICB.

ACCESS SERVICE

10. Rates and Charges (Cont.)

Special Access Service (Cont.) #

	<u>Monthly Rates</u>	<u>Non Recurring Charges</u>
(D) <u>High Capacity</u>		
(1) <u>Channel Termination</u> Per Termination*		
– DS1 1.544 Mbps	ICB	ICB
– DS3 44.736 Mbps	ICB	ICB
(2) <u>Channel Mileage Facility</u> Per Mile		
– DS1 1.544 Mbps	ICB	NA
– DS3 44.736 Mbps	ICB	NA
(3) <u>Channel Mileage</u> <u>Termination</u> Per Termination		
– DS1 1.544 Mbps	ICB	NA
– DS3 44.736 Mbps	ICB	NA
(4) <u>Multiplexing per</u> <u>Arrangement</u>		
– DS1 to Voice	ICB	
– DS3 to DS1	ICB	
(E) <u>Special Access Surcharge</u> Per Voice Grade Equivalent	ICB	NA
(F) <u>Term Discounts</u>	ICB	ICB

* The Channel Termination rate includes non-chargeable Channel Interface as set forth in Section 7.1.4, preceding.

Rates and charges for other special access services, optional features, or bit rates are ICB.

ACCESS SERVICE

10. Rates and Charges (Cont.)

Miscellaneous Services

	<u>Per Line Per Request</u>
(A) <u>Presubscription</u> Per Telephone Exchange Service Line or Trunk	\$ 5.00*
(B) <u>Block Services</u>	
(1) <u>International Blocking Service</u>	\$ 35.00
(2) <u>900 Blocking Service</u>	
a. Blocking	
1st Request	\$ 0.00
Each Request Thereafter	11.20
b. Unblocking	
1st Request	\$ 0.00
Each Request Thereafter	\$ 11.20
(C) <u>Billing Name and Address Information</u>	
Per Request Incidence	
– Per BNA Order	\$ 50.94
– Per BNA Record	\$.33
Optional Magnetic Tape	
– Charge per Magnetic Tape	\$ 91.44
Optional Format Programming Charge	
– Per each half hour or fraction thereof	\$ 37.20

* This charge is generally billed to the end user who is the subscriber to the Telephone Exchange Service. In those instances where the IC both requests the presubscription change, and requests the associated charge be billed to it, the telephone company will bill the IC. In the event an end user is incorrectly presubscribed due to misassignment on the part of the telephone company, no charge shall apply. In the event an end user is incorrectly presubscribed due to misassignment on the part of the IC, and the IC is unable to document such an assignment, the telephone company will apply the charge to the IC responsible for the misassignment of the end user and assign the end user to an IC of the end user's choice.

ACCESS SERVICE

10. Rates and Charges (Cont.)

Miscellaneous Services (Cont.)

	<u>Per Line Per Request</u>
(D) <u>Unauthorized PIC Change</u>	
– Residence/Business Per Telephone Exchange Service Line or Trunk	\$ 35.65
– Public and/or Semi-Public Pay Telephone Exchange Service Line or Trunk	\$ 57.57
(E) Access Order Charge Per Order	\$ 136.00
(F) Access Service Request Modifications#	\$ 53.00
(G) Originating Line Screening (OLS) Service	
– Per exchange service line	\$ 7.95

This applies to Service Date Change Charges (per order), Design Change Charges (per order) and Miscellaneous Service Order Charges (per occurrence).

ACCESS SERVICE

10. Rates and Charges (Cont.)

Miscellaneous Services (Cont.)

	Basic Time Scheduled Working Hours	Overtime Outside Scheduled Working Hours	Premium Time Outside of Scheduled Work Day
(H) <u>Additional Engineering Periods</u> Per engineer, 1/2 hour or Fraction thereof,	\$ 21.25	\$ 31.88	\$ 42.50
(I) <u>Additional Labor</u> Per technician, 1/2 hour or Fraction thereof,			
Installation or Repair	\$ 21.07	\$ 31.25*	\$ 41.66*
Stand By	\$ 21.07	\$ 31.61*	\$ 42.14*
(J) <u>Testing and Maintenance or Other Labor**</u> Per technician, 1/2 hour or Fraction thereof,			
Installation and Repair Tech	\$ 20.83	\$ 31.25*	\$ 41.66*
Central Office Maintenance Tech	\$ 21.03	\$ 31.54*	\$ 42.05*
(K) <u>Programming Services</u> Per programmer, 1/2 hour or fraction thereof,	\$ 55.00	\$ 82.50	

* A call out of a telephone company employee at a time not consecutive with the employee's scheduled work period is subject to a minimum charge of four hours.

** Includes testing with other telephone companies and/or additional Cooperative Acceptance testing.

ACCESS SERVICE

10. Rates and Charges (Cont.)

Miscellaneous Services (Cont.)

(L) Additional Automatic Testing - Switched Access

To First Point of Switching

Additional Tests	<u>Per Test Per Transmission Path</u>
Gain-Slope Tests	\$2.89
C-Notched Noise Tests	\$2.89
1004 Hz Loss**	\$2.89
C-Message Noise**	\$2.89

**1004 Hz Loss, C-Message Noise and Balance are non-chargeable routine tests; however, they may be requested on an as needed or more than routine scheduled basis, in which case the charges herein apply.

(M) Additional Manual Testing - Switched Access

To First Point of Switching

Additional Tests	Each Half Hour or Fraction Thereof
Gain-Slope, C-Notched Noise and any other agreed to tests per technician	See the rates for Additional Labor as set forth preceding.*

* A call out of a telephone company employee at a time not consecutive with the employee's scheduled work period is subject to a minimum charge of four hours.

ACCESS SERVICE

10. Rates and Charges (Cont.)

Miscellaneous Services (Cont.)

(N) Maintenance of Service

Maintenance of Service Periods

Each Half Hour or Fraction Thereof

Basic Time,
Overtime* and
Premium Time*

See the rates for Additional Labor
as set forth preceding.*

(O) Telecommunications Service Priority

Nonrecurring
Charge

Per service arranged

\$54.63

*A call out of a telephone company employee at a time not consecutive with the employee's scheduled work period is subject to a minimum charge of four hours.

ACCESS SERVICE

10. Rates and Charges (Cont.)

Miscellaneous Services (Cont.)

Reserved for Future Use

ACCESS SERVICE

10. Rates and Charges (Cont.)

Miscellaneous Services (Cont.)

Reserved for Future Use

Individual Case Basis Arrangements

When the Company furnishes a facility or service for which a rate or charge is not specified in the Company's tariff, charges will be determined on an ICB. Specialized rates or charges will be made available to similarly situated Customers on a nondiscriminatory basis

VOIP – PSTN SERVICE RATES#

Interstate Access Rates applicable to the Intrastate VoIP Traffic can be found in Section 10 of the OLSEN THIELEN & CO., LTD. Tariff F.C.C. No.1 at;

<https://apps.fcc.gov/etfs/public/lecTariffs.action?idLec=358>

#Per FCC Second Order on Reconsideration as noted in Section 6.1, intrastate access rates will apply to originating interstate VoIP traffic from July 13, 2012 to June 30, 2014.