

Weld Procedures Specification NO. EQ52V Rev. 0

For shielded metal arc welding of pipe and fittings have a specified minimum yield strength for greater than 42,000 but equal to or less than 52,000 pounds per square inch. Examples: API 5L Grade X46, X48 and X52 pipe. MSS SP-75 Class WPHY-46 and WPHY-52 welding fittings. Also, these materials welded to materials listed for WPS EQ42V.

Process:*	Manual type SMAW
Material:*	42,000 PSI < SMYS ≤ 52,000 PSI and SMYS ≤ 42,000 PSI welded to 42,000 PSI < SMYS ≤ 52,000 PSI
Diameter:	All diameters
Wall thickness:*	3/16 inch ≤ thickness ≤ 3/4 inch
Joint design:*	"V" Groove (30° or 37 ½ °) (See sketch pg. 2 of 2)
Fill metal:*	Group 1 (E6010 or E7010) all beads or Group 1 root Bead and Group 2 (E8010) remainder.
Electrical characteristics:*	DC reverse polarity
Position:*	5G – run pipe horizontal fixed ± 15°
Direction of welding:*	Vertical downhill
No. of welders:	One or multiple
Time lapse between passes:*	Maximum 5 minutes between root and second pass for all Group 1 filler metal welds or maximum 7 minutes between root and second pass for Group 1 and Group 2 filler metal welds. Maximum 10 minutes between second and third pass.
Type and removal of lineup clamp:	None, external or internal clamp; minimum 50% of root Bead complete before removal
Cleaning and/or grinding:	Power tools
Preheat/stress relief:	None
Shielding gas and flow rate:*	NA
Shielding flux:*	NA
Speed of travel:*	4 – 15 inches per minute

**Changes to these variables requires weld procedure re-qualification. WPS in accordance with API 1104.
Sketches and tabulations – page 2 of 2.*

Bear Tracker Energy, LLC
 Weld Procedure Specifications

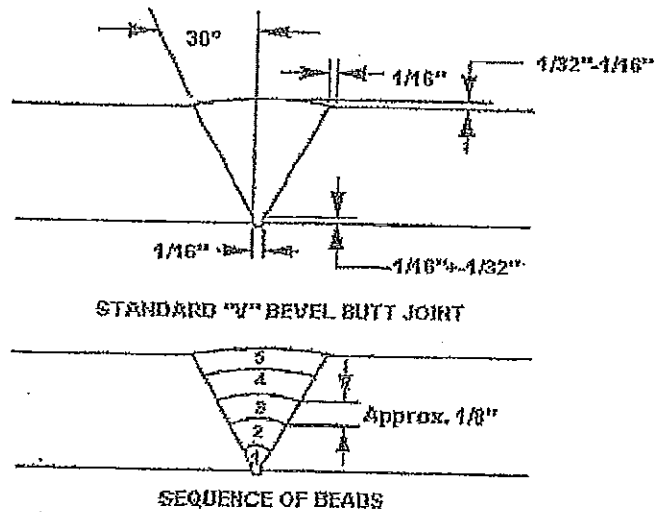

Electrode Size And Number of Beads				
Bead Number	Electrode Size & Type	Voltage Range	Amperage Range	Speed IPM
1	1/8" E6010/7010	20 - 25	75 - 130	6 - 12
1	5/32" E6010/7010	22 - 27	90 - 175	9 - 15
2	1/8" E7010 or E8010	20 - 25	75 - 130	5 - 10
2	5/32" E7010 or E8010	22 - 30	90 - 185	4 - 8
3-4	5/32" E7010 or E8010	22 - 30	90 - 185	4 - 8
3-4	3/16" E7010 or E8010	25 - 30	140 - 225	4 - 8

Minimum three weld beads for pipe wall thickness < 0.25 inch.

Minimum four weld beads for pipe wall thickness > 0.25 inch.