



November 11, 2014
Via Overnight Delivery
(Plus E-Mailed Copy)

Mr. Darrell Nitschke, Executive Secretary
North Dakota Public Service Commission
600 East Boulevard Avenue
Department 408
Bismarck, ND 58505-0480



**RE: Onvoy, LLC fka Onvoy, Inc.
Name Change Replacement Tariff
North Dakota Tariff No. 1**

Dear Mr. Nitschke:

Enclosed for filing please find the original of the above referenced tariff submitted on behalf of Onvoy, LLC formerly known as Onvoy, Inc. The purpose of this filing is to replace the current tariff on file to change the name from Onvoy, Inc., to Onvoy, LLC. No material changes have been made to this tariff other than formatting, page renumbering, and corrections to paragraph numbering. The Company respectfully requests an effective date for this filing of November 12, 2014.

Please acknowledge receipt of this filing by date-stamping the extra copy of this cover letter and returning it to me in the self-addressed, stamped envelope provided for that purpose.

Any questions you may have regarding this filing should be directed to my attention at 407-740-3006 or via email to croesel@tminc.com. Thank you for your assistance in this matter.

Sincerely,

600 Carey Roesel
Consultant to Onvoy, LLC

cc: Scott Sawyer - Onvoy
file: Onvoy - ND Access
tms: NDa1401

Enclosures

CR/bc

1 **PU-14-814** Filed: 11/12/2014 Pages: 62
Revision to North Dakota Tariff No. 1 – name change

Onvoy, LLC

Carey Roesel, Technologies Management

*This tariff, Onvoy, LLC's North Dakota Tariff No. 1, replaces in its entirety
Onvoy, Inc.'s North Dakota Intrastate Tariff, which is currently on file with the Commission.*

ONVOY, LLC

REGULATIONS AND SCHEDULE OF CHARGES

APPLYING TO

ACCESS SERVICES FURNISHED

IN THE STATE OF NORTH DAKOTA

CHECK SHEET

Sheets of this tariff are effective as of the date shown at the bottom of the respective sheet(s). Original and revised pages as named below comprise all changes from the original tariff that are currently in effect as of the date on the bottom of this sheet.

<u>Page</u>	<u>Revision</u>		<u>Page</u>	<u>Revision</u>		<u>Page</u>	<u>Revision</u>	
1	Original	*	31	Original	*	61	Original	*
2	Original	*	32	Original	*			
3	Original	*	33	Original	*			
4	Original	*	34	Original	*			
5	Original	*	35	Original	*			
6	Original	*	36	Original	*			
7	Original	*	37	Original	*			
8	Original	*	38	Original	*			
9	Original	*	39	Original	*			
10	Original	*	40	Original	*			
11	Original	*	41	Original	*			
12	Original	*	42	Original	*			
13	Original	*	43	Original	*			
14	Original	*	44	Original	*			
15	Original	*	45	Original	*			
16	Original	*	46	Original	*			
17	Original	*	47	Original	*			
18	Original	*	48	Original	*			
19	Original	*	49	Original	*			
20	Original	*	50	Original	*			
21	Original	*	51	Original	*			
22	Original	*	52	Original	*			
23	Original	*	53	Original	*			
24	Original	*	54	Original	*			
25	Original	*	55	Original	*			
26	Original	*	56	Original	*			
27	Original	*	57	Original	*			
28	Original	*	58	Original	*			
29	Original	*	59	Original	*			
30	Original	*	60	Original	*			

TABLE OF CONTENTS

CHECK SHEET..... 2

TABLE OF CONTENTS 3

EXPLANATION OF SYMBOLS..... 4

INTERCONNECTING CARRIERS..... 5

APPLICATION OF TARIFF 5

SECTION 1 - DEFINITIONS 6

SECTION 2 - GENERAL REGULATIONS 12

SECTION 3 - SERVICE CONNECTION CHARGES..... 31

SECTION 4 - SPECIAL ACCESS SERVICES 34

SECTION 5 - SWITCHED ACCESS SERVICES 39

SECTION 6 - ORDERING OPTIONS FOR SWITCHED AND SPECIAL ACCESS SERVICE 52

EXPLANATION OF SYMBOLS

The following symbols are applicable to all sections of this Tariff:

- (C) Signifies a changed regulation.
- (D) Signifies a discontinued rate, treatment, or regulation.
- (I) Signifies an increased rate or new treatment resulting in an increased rate.
- (M) Signifies a move of text from one area of the tariff to another, but no change in rate, treatment, or regulation.
- (N) Signifies a new rate, treatment, or regulation.
- (R) Signifies a reduced rate or new treatment resulting in reduced rate.
- (T) Signifies a change in text but no change in rate, treatment, or regulation.

INTERCONNECTING CARRIERS

A. CONCURRING CARRIERS

None

B. CONNECTING CARRIERS

Onvoy reserves the right to interconnect its services with those of any authorized Common Carrier, Local Exchange Carrier, or alternate access provider of its choice, and to utilize such services to provide the services described herein.

APPLICATION OF TARIFF

This tariff applies to competitive access services, between and among points within the State of North Dakota furnished by Onvoy, LLC.

This Tariff does not apply to carriers with whom the Company has a written agreement for different intercarrier compensation.

BY UTILIZING THE EXCHANGE ACCESS SERVICES SET FORTH IN THIS TARIFF, CARRIERS ARE DEEMED TO HAVE CONSTRUCTIVELY ORDERED SERVICE AS CUSTOMERS, AND AGREE TO THE SERVICE RATES, CHARGES, TERMS, AND CONDITIONS AS SET FORTH HEREIN.

SECTION 1 - DEFINITIONS

Access Circuit: A switched or dedicated access line provided by the local exchange carrier to Onvoy or between the customer location and an Onvoy point of presence.

Access Code: A uniform five or seven digit code assigned by Onvoy to an individual customer. The five digit code has the form 10XXX, and the seven digit code has the form 101XXXX.

Access Service: Switched or Special Access to the network of an Interexchange Carrier for the purpose of originating or terminating communications.

Access Service Request (ASR): The industry service order format used by Access Service customers and access providers as agreed to by the Ordering and Billing Forum (OBF).

Access Tandem: An Exchange Carrier's switching system that provides a concentration and distribution function for originating or terminating traffic between local switching centers and customers' premises.

Alternate Access: Alternate Access has the same meaning as Local Access except that the provider of the service is an entity other than the Local Exchange Carrier authorized or permitted to provide such service. The charges for Alternate Access may be specified in a private agreement rather than in a published or special tariff if private agreements are permitted by applicable governmental rules.

Authorized User: Any person, firm, employee, or corporation that is authorized by the customer to place or receive calls under a service agreement with Onvoy.

Bit: The smallest unit of information in the binary system of notation.

Cancellation: Customer-initiated cancellation of a pending service order.

SECTION 1 - DEFINITIONS (CONT'D)

Channel(s): An electrical or, in the case of fiber optic-based transmission systems, a photonic communications path between two or more points of termination.

Common Channel Signaling (CCS): A high speed packet switched communications network which is separate (out of band) from the public packet switched and message networks. It is used to carry addressed signaling messages for individual trunk circuits and/or database related services between signaling points in the CCS network.

Common Language Location Identifier (CLLI): The naming convention of the telephone switch locations- starts with a 4 character city abbreviation followed by a 2 digit character state abbreviation followed by a series of alpha numeric characters.

Conventional Signaling: The inter-machine signaling system has been traditionally used in North America for the purpose of transmitting the called number's address digits from the originating Local Switching Center which terminates the call. In this system, all of the dialed digits are received by the originating switching machine, a path is selected and the sequence of supervisory signals and outpulsed digits is initiated. No overlap outpulsing ten digit ANI, ANI information digits, or acknowledgment link are included in this signaling sequence.

Customer: The person, firm, corporation or other entity which orders Service and is responsible for the payment of charges and for compliance with Onvoy's tariff regulations.

Dedicated: A facility or equipment or subsystem set aside for the sole use of a specific customer.

DS1: DS1 refers to digital signal, level 1, the first tier of high speed telecommunications service operating at 1.544 Mbps.

Duplex Service: Service which provides for simultaneous transmission in both directions.

End User: An individual, association, corporation, governmental agency or any other entity other than an Interexchange Carrier which subscribes to intrastate service, provided by an Exchange Carrier that does not resell those services.

Entrance Facility: The dedicated Switched Access transport facility from the customer premise to the Onvoy serving wire center.

Exchange Carrier: Any individual, partnership, association, trust, governmental entity or corporation engaged in the provision of interexchange telephone service.

SECTION 1 - DEFINITIONS (CONT'D)

Fiber Optic Cable: A thin filament of glass with a protective outer coating through which a light beam carrying communications signals may be transmitted by means of multiple internal reflections to a receiver, which translates the message.

Firm Order Confirmation (FOC): Acknowledgment by Onvoy of receipt of an Access Service Request from the Customer and commitment by Onvoy of a Service Date.

Individual Case Basis (ICB): A service arrangement in which the regulations, rates and charges are developed based on the specific circumstances of the Customer's situation.

Interexchange Carrier (IXC) or Interexchange Common Carrier: An IXC provides long distance service between LATAs, therefore, an example would be a long distance company. As compared with a Local Exchange Carrier (LEC), an IXC provides the long distance (intraLATA/interLATA) piece of the call, whereas the LEC provides the local piece.

Kbps: Kilobits, or thousands of bits, per second.

LATA: Local Access Transport Areas were established by the Modified Final Judgment (MFJ) in the divestiture of AT&T to delineate the areas where Bell Operating Companies could offer services.

Local Exchange Carrier (LEC): An individual, partnership, association, trust, government entity or corporation engaged in the provision of local or interexchange telephone services. LEC entities can include Incumbent Local Exchange Carriers (ILECs) or Competitive Local Exchange Carriers (CLECs).

Local Access: The connection between a customer's premises and a point of presence of the Exchange Carrier.

Local Switching Center: The switching center where telephone exchange service customer station Channels are terminated for purposes of interconnection to each other and to interoffice Trunks.

Mbps: Megabits, or millions of Bits, per second.

MOU: Minutes of use.

NPA: Numbering Plan Area (Area Code).

Non-Recurring Charges (NRC): The one-time initial charges for services or facilities, including but not limited to, charges for construction, installation, or special fees, for which the customer becomes liable at the time the Service Order is executed.

SECTION 1 - DEFINITIONS (CONT'D)

Off-Hook: The active condition of Switched Access or a telephone exchange service line. Example: The receiver of the telephone set is ready to dial a phone number or is ready for a conversation.

On-Hook: The idle condition of switched access or a telephone exchange service line. Example: The status of the receiver of a telephone is ready for an incoming call. It is not possible to hold a conversation during On-Hook status.

Onvoy or Company: Means Onvoy, LLC.

Out of Band Signaling: An exchange access signaling feature which allows customers to exchange call control and signaling information over a communications path which is separate from the message path.

Point of Interconnection (POI): The demarcation point or network interface on the Company's premises between the Company's facilities and the Customer's facilities.

Point of Presence (POP): Location where the customer maintains a facility for purpose, of interconnecting to Onvoy's Network.

Premises: The space occupied by a Customer or Authorized User in a building or buildings or on contiguous property (except railroad rights-of-way, etc.).

Presubscription: An arrangement whereby an End User may select and designate to Onvoy an Interexchange Carrier (IXC) or Carriers it wishes to access, without an Access Code, for completing both intraLATA toll calls and/or interLATA calls. The selected IXC (s) are referred to as the End-User's Primary Interexchange Carrier (PIC). The End User may select any IXC that orders FGD Switched Access Service at the Local Switching Center that serves the End User.

Recurring Charges: The monthly charges to the Customer for services, facilities and equipment which continue for the agreed upon duration of the service.

Service Commencement Date: For Special Access Service and Direct Connect Switched Access Service the first day following the date on which Onvoy notifies the Customer that the requested service or facility is available for use. Unless extended by the Customer's refusal to accept service which does not conform to standards set forth in the Service Order or this tariff, in which case the Service Commencement Date is the date of the Customer's acceptance of service. The parties may mutually agree on a substitute Service Commencement Date. If Onvoy does not have an executed Service Order from a Customer, the Service Commencement Date will be the first date on which the service or facility was used by the customer. For Tandem Connect Customers, the Service Commencement Date will be the first date on which the service or facility was used by the Customer.

SECTION 1 - DEFINITIONS (CONT'D)

Service Order: The written request for Network Services executed by the Customer and Onvoy in a format devised by Onvoy, or, in the alternative, the submission of an Access Service Request by the Customer in the manner specified in this tariff. The signing of a Service Order or submission of an ASR by the Customer and acceptance thereof by Onvoy initiates the respective obligations of the parties as set forth therein and pursuant to this tariff, but the duration of the service is calculated from the Service Commencement Date.

Service(s): Onvoy's telecommunications Access Services offered on Onvoy's Network.

Serving Wire Center (SWC): The local Onvoy office from which dial tone for local exchange service would normally be provided to the Customer premises.

Shared Facilities: A facility or equipment system or subsystem which can be used simultaneously by several customers.

Signaling Point of Interface: The Customer designated location where the SS7 signaling information is exchanged between Onvoy and the Customer.

Signaling System 7 (SS7): The common Channel Out of Band Signaling protocol developed by the Consultative Committee for International Telephone and Telegraph (CCITT) and the American National Standards Institute (ANSI).

Signaling Transfer Point Access: Allows the Customer to access a specialized switch which provides SS7 network access and performs SS7 messaging routing and screening.

SECTION 1 - DEFINITIONS (CONT'D)

Special Access Service: Dedicated access between a Customer's Premises and another Point of Presence for the purpose of originating or terminating communications. Special Access is available to both carriers and end users, as defined in this tariff.

Switched Access Service: Access to the switched network of an Exchange Carrier for the purpose of originating or terminating communications. Switched Access is available to carriers, as defined in this tariff.

Tandem Switched Transport (TST): The transport between the SWC and wire centers or between an access tandem and wire centers that subtend the access tandem.

Trunk: A communications path connecting two switching systems in a network, used in the establishment of an end-to-end connection.

V&H: The vertical and horizontal coordinates which identify the location of a city or wire center according to global coordinates. Used to calculate mileage between switch locations for the purpose of calculating mileage rates.

VoIP-PSTN Traffic: VoIP-PSTN Traffic is traffic exchanged between the Company and the Customer in Time Division Multiplexing (TDM) format that originates and/or terminates in Internet Protocol (IP) format.

Wire Center: A building in which central offices, used for the provision of Telephone Exchange services, are located.

SECTION 2 - GENERAL REGULATIONS

The regulations set forth herein apply to intrastate access telecommunications services and facilities furnished within the State of North Dakota by Onvoy.

When services and facilities are provided in part by the Company and in part by other companies, the regulations of the Company apply to that portion of the service or facilities furnished by it.

2.1 Undertaking of the Company

The Company undertakes to provide the services offered in this Tariff on the terms and conditions and at the rates and charges specified. This undertaking is dependent upon the availability of facilities. The facilities used to provide a particular service shall be chosen by the Company and are not represented to be suitable for any one service.

SECTION 2 - GENERAL REGULATIONS (CONT'D)

2.2 Liability of the Company

- A. The liability of the Company for damages arising out of mistakes, omissions, interruptions, delays, errors or defects in transmission occurring in the course of furnishing telecommunications service and not caused by negligence of the customer, shall in no event exceed an amount equivalent to the proportionate charge to the customer for the period of service during which such mistakes, omissions, interruptions, delays or errors or defects in transmission occur. No other liability shall in any case attach to the Company. The above described remedies in favor of customer are exclusive and in no event shall the Company, its contractors and agents be liable to or responsible for customer or any other person or entity with respect to any other liability, loss or damage, arising out of, caused or alleged to be caused, directly or indirectly, by the Company, including but not limited to any death, bodily injury, an interruption of service, loss of business or profits or any indirect, special, or consequential damages.
- B. The customer indemnifies and saves the Company harmless (including costs and reasonable attorneys' fees) against the following:
1. Acts or omissions of other companies when their facilities are used in connection with the Company's facilities to provide service.
 2. Any defacement or damage to the customer's premises resulting from the existence of the Company's instruments, apparatus and associated wire on such premises, or from the installation or removal thereof, when such defacement or damage is not the result of the negligence of the Company, or its employees.
 3. Any accident, injury, or death occasioned by its equipment or facilities when such is not due to negligence of the Company.
 4. Claims for libel, slander, or infringement of copyright arising directly or indirectly from the material transmitted or recorded over its facilities; claims or infringement of patents arising from combining with, or using in connection with, facilities of the Company, apparatus, systems and their associated wiring of the customer; and against all other claims arising out of any act or omission of the customer in connection with facilities provided by the Company.
 5. Liability for failure to provide service.

SECTION 2 - GENERAL REGULATIONS (CONT'D)

2.2 Liability of the Company (Cont'd)

C. The customer indemnifies and saves the Company harmless against any accident, injury or death caused through the use of apparatus which fail to meet the dielectric requirements as established by the Company when such apparatus is provided by the customer. The Company has the right of refusing to, or ceasing to, render service to a customer if at any time any of the telephones, appliances, lines or apparatus on the customer's premises shall be considered unsafe by Company personnel, or if the use of the service shall be prohibited by or forbidden under any law, ordinance or regulation.

D. Customer Owned Equipment:

Upon request of customer for trouble a visit charge will be made if trouble is found to be in customer provided systems.

The Company shall not be responsible for the installation, operation, or maintenance of any customer-provided systems. Exchange and message toll telephone services are not represented as adapted to the use of customer-provided systems where such systems are connected to the Company facilities. The responsibility of the Company shall be limited to the furnishing of facilities suitable for exchange and message toll services and to the maintenance and operation of such facilities in a manner proper for such services; subject to this responsibility the Company shall not be responsible for the through transmission of signals generated by the customer-provided systems or for the quality of, or defects in, such transmission or the reception of signals by customer-provided systems.

The Company shall not be responsible to the customer or otherwise if changes in the criteria or in any of the facilities, operations or procedures of the Company render any customer provided facilities obsolete or require modification or alteration of such facilities or otherwise affect its use or performance. Where it is reasonably foreseeable to the Company that such changes may affect customer provided facilities, the Company shall provide reasonable notice.

SECTION 2 - GENERAL REGULATIONS (CONT'D)

2.3 Use of Service

A. General

Service is furnished for use by the customer and may be used only by others as specifically provided elsewhere in this Tariff.

B. Unlawful Use of Service

Service shall not be used for any unlawful purpose. The Company may refuse to furnish service to an applicant or may disconnect the service of a customer when:

- 1) A government law enforcement agency, acting within its jurisdiction, advises the Company that such service is being used or will be used unlawfully or for an unlawful purpose, or
- 2) The Company has other information which reasonably causes it to believe that such service is being used or will be used unlawfully or for an unlawful purpose.

C. Obscenity

Service shall not be used to make any oral or written comment, request, suggestion or proposal, or to transmit any nonverbal material which is obscene, lascivious, filthy or indecent or otherwise not protected by law.

D. Impersonation

Service shall not be used to impersonate another person with fraudulent or malicious intent.

E. Harassment

Service shall not be used to call another person so frequently or at such times of day or in any manner so as to annoy, abuse, threaten or harass such other person.

SECTION 2 - GENERAL REGULATIONS (CONT'D)

2.3 Use of Service (Cont'd)

F. Fraudulent Use

- 1) Service shall not be used to transmit a message, to locate a person, or to otherwise give or obtain information without payment of the charges applicable to such use.
- 2) No device shall be used by a customer with the service or facilities of the Company for the purpose of avoiding payment of the applicable charge.

G. Interference With or Impairment of Service

Service shall not be used in any manner which interferes with another person in the use of service, prevents another person from using service, or otherwise impairs the quality of service to other customers.

H. Subscribing to Adequate Service

If a customer's use of service interferes unreasonably with the service of other customers, he will be required to take service in sufficient quantity or of a different class or grade.

I. Resale of Service

The resale of service is not permitted unless the customer is in compliance and certified under Section 214 of the Communications Act, and as may be excepted in this Tariff.

J. Location of Service

Service shall not be located in such a manner as to enable other than authorized users to use the service.

SECTION 2 - GENERAL REGULATIONS (CONT'D)

2.4 Applications for Service

- A. An application for service made in writing establishes the contract between the Company and the customer on the terms and conditions set forth in this Tariff. Neither the contract nor any rights acquired there under may be assigned or in any manner transferred.
- B. Any change in rates or regulations prescribed by the North Dakota Public Service Commission modifies the terms and regulations of contracts to the extent of such change.

2.5 Minimum Contract Periods

- A. Except as otherwise provided, the minimum contract period is one month for all services furnished.
- B. The Company may require a minimum contract period longer than one month at the same location in connection with special (nonstandard) types or arrangements of equipment, or for unusual construction, necessary to meet special demands and involving extra costs.

SECTION 2 - GENERAL REGULATIONS (CONT'D)

- 2.6 Cancellation of Application for Service Prior to Establishment of Service
- A. Where the applicant cancels an order for service prior to the start of installation or special construction of facilities, no charge applies.
 - B. Where installation of facilities, other than those provided by special construction, has been started prior to the cancellation, the lower of the following charges applies:
 - 1) The total costs (including overheads) in connection with providing and removing such facilities.
 - 2) The monthly charges for the entire initial contract period of the service ordered by the customer as provided in this Tariff plus the full amount of any installation and termination charges applicable.
 - C. Where special construction of facilities has been started prior to cancellation, and there is another requirement for the specially constructed facilities in place, no charge applies.
 - D. Where special construction of facilities has been started prior to the cancellation, and there is no other requirement for the specially constructed facilities, a charge equal to the costs incurred in the special construction (including overhead) applies. Where one or more, but not all, of the service involved in the special construction are canceled, a charge equal to the cost (including overheads) incurred for the discontinued service applies.
 - E. Installation or special construction of facilities for a customer starts when the Company incurs any expense in connection therewith which would not otherwise have been incurred and the Customer has advised the Company to proceed with the installation or special construction.

SECTION 2 - GENERAL REGULATIONS (CONT'D)

2.7 Advance Payments

- A. At the time an application for service is made, an applicant may be required to pay an amount equal to at least one month's service and/or installation charges which may be applicable, in addition to such special construction and installation charges as are to be borne by the applicant. The amount of the advance payment is credited to the customer's account on the first bill rendered.
- B. Federal, State or Municipal governmental agencies may not be required to make advance payments.

2.8 Credit Policy

A. Deposit and Guarantee Requirements

The Company will not require deposits from North Dakota customers.

2.9 Customer Billing

- A. Regular bills will be issued periodically (monthly, quarterly). For billing purposes each month is presumed to have thirty days.
- B. Services which are charged for at monthly rates are billed in advance for one month's service.
- C. Services which are charged for at other than monthly rates are billed in arrears.
- D. Retroactive billing adjustments will not be made for a period exceeding three years.

SECTION 2 - GENERAL REGULATIONS (CONT'D)

2.10 Payment for Service

- A. The customer is responsible for the payment of rates and charges for all services furnished including, but not limited to, calls originated or received at a customer's service location.
- B. Bills are due when rendered and may be paid at any of the Company's public business offices or other authorized payment locations.
- C. Non-sufficient Fund or No Account Checks

When a customer pays the monthly bill with a non-sufficient fund or no account check, a charge (see Section 3.2) will be made to that customer to cover the administrative costs incurred in handling the transaction.

SECTION 2 - GENERAL REGULATIONS (CONT'D)

2.10 Payment for Service (Cont'd)

D. Customer Complaints and/or Billing Disputes

Customer inquiries or complaints regarding service or accounting may be made in writing or by telephone to the Company at:

300 South Highway 169, Suite 700
Minneapolis, Minnesota 55426
763-230-2036
1-800-933-1224, option 4
customercare@onvoy.com

Any objection to billed charges should be reported promptly to the Company. Adjustments to Customers' bills shall be made to the extent that records are available and/or circumstances exist which reasonably indicate that such charges are not in accordance with approved rates or that an adjustment may otherwise be appropriate. Where over billing of a customer occurs, due either to Company or customer error, no liability exists which will require the Company to pay any interest, dividend or other compensation on the amount over billed.

If after an investigation and review by the Company a disagreement remains as to the disputed charges, the customer may file a complaint, in writing or by telephone, to:

North Dakota Public Service Commission
600 E. Boulevard, Dept. 408
Bismarck, ND 58505-0480
701.328.2400 [phone)
<http://www.psc.state.nd.us/>

SECTION 2 - GENERAL REGULATIONS (CONT'D)

2.11 Failure to Pay for Service

A. Regular Monthly Bills

- 1) A customer is considered to be delinquent in the payment of a regular monthly bill when the sum due is not received on or before the twenty fifth-calendar day following the day the bill is either mailed or delivered by other means.
- 2) When a customer is delinquent in the payment of a regular monthly bill, the Company may disconnect the service after giving a customer five (5) days (excluding Sundays and legal holidays) written notice of intention to disconnect. Written notice may be mailed or delivered by a representative of the Company. Service shall not be disconnected on any Friday, Saturday, Sunday, or legal holiday, or at any time when the Company's business offices are not open to the public, except where an emergency exists.

2.12 Restoral of Telecommunications Service

- A. If a customer's service is restored after having been disconnected in accordance with this Tariff and a Company service order to terminate such service has not been completed when such service is restored, the customer will be required to pay Service Charges specified in Section 3.2 of this Tariff. Monthly service rates will not apply for the period between the disconnection and reconnection.
- B. When a customer's service has been disconnected in accordance with this Tariff and the service has been terminated through the completion of a Company service order, service will be re-established only upon the basis of an application for new service.

SECTION 2 - GENERAL REGULATIONS (CONT'D)

2.13 Ownership of Facilities

Telecommunications facilities furnished by the Company remain the property of the Company until transferred or abandoned or except as otherwise provided in this tariff.

2.14 Access to Facilities

The customer shall provide employees and agents of the Company access to Company facilities, at all reasonable times.

2.15 Rearrangement, Repair, Maintenance, Disconnection and Removal of Facilities

- A. All facilities owned by the Company will be maintained by it, except where such facilities are situated, in the judgment of the Company, in hazardous or inaccessible locations.
- B. Customers may not rearrange, disconnect, remove or otherwise tamper with, or permit others to rearrange, disconnect, remove or tamper with any facilities owned by the Company, except with the Company's written consent, or as specified elsewhere in this tariff.

2.16 Damage, Loss or Destruction of Company Facilities

All ordinary expense of maintenance and repair of Company facilities, unless otherwise specified in this Tariff, are borne by the Company. If any of the Company's facilities are damaged, lost or destroyed and not due to ordinary wear and tear, the customer is held responsible for the cost of replacing the lost or destroyed facilities or restoring the damaged facilities to their original condition, except when caused by the negligence of the Company.

SECTION 2 - GENERAL REGULATIONS (CONT'D)

2.17 Interruptions to Service

- A. When service is interrupted and the interruption exceeds a 24-hour period (as measured from the time the interruption is reported to or detected by the Company, whichever occurs first, unless otherwise stated in another Section of this Tariff or that of a connecting company which governs), a credit allowance will be made, at the customer's request, for the service which is rendered useless and inoperative due to the interruption.
- B. A credit allowance will not be given for:
- 1) Interruptions caused by the negligence or willful act of the customer.
 - 2) Interruptions caused by customer-provided facilities.
 - 3) Interruptions caused by electric power failure where the customer furnishes such electric power.
- C. The credit allowance will be based upon the ratio of the duration of the service interruption (measured from the time the interruption is reported to or detected by the Company, whichever occurs first) to the total time in a 30 day month. That ratio, multiplied by the monthly rate for the service affected shall determine the amount of the credit allowance. No other liability shall attach to the Company in consideration of such interruption to service. Retroactive billing adjustments will not be made for a period exceeding three years.

SECTION 2 - GENERAL REGULATIONS (CONT'D)

2.18 Limiting of Communications

The Company may limit communications over its facilities during emergencies which result in a shortage of facilities.

2.19 Termination of Telecommunications Service

- A. Telecommunications service may be terminated prior to the expiration of the minimum contract period upon notice being given to the Company in advance and upon payment of the termination charges given below in addition to all charges due for service which has been furnished.
- 1) In the case of service for which the minimum contract period is one month, the termination charges are the charges due for the balance of the initial month.
 - 2) In the case of special equipment for which the minimum contract period is in excess of one month at the same location, such proportion of the sum of the cost of the equipment and of its installation, plus the cost of removal, less the salvage value of the equipment removed, as the unexpired portion of the minimum contract period bears to the full minimum contract period.
- B. Telecommunications service may be terminated after the expiration of the minimum contract period, upon the Company being notified in advance and upon payment of all charges due to the date of termination of the service.

SECTION 2 - GENERAL REGULATIONS (CONT'D)

2.20 Disconnection of Telecommunications Service

A. The company may discontinue service to a customer under the conditions set forth below in accordance with North Dakota PSC rules. In general the Company will provide five days written notice prior to disconnection. Disconnection without notice will occur under any of the following conditions:

- 1) without notice in the event of tampering with the company's equipment;
- 2) without notice in the event of a condition determined to be hazardous to the customer, to other customers of the company, to the company's equipment, the public, or to employees of the company; or
- 3) without notice in the event of a customer's use of equipment in such a manner as to adversely affect the company's equipment or the company's service to others.
- 4) without notice in the event of unauthorized use;
- 5) for violation of or noncompliance with the Company's rules in this tariff, the requirements of municipal ordinances or law pertaining to the service.

SECTION 2 - GENERAL REGULATIONS (CONT'D)

2.20 Disconnection of Telecommunications Service (Cont'd)

A. (Cont'd)

- 6) for failure of the customer or prospective customer to furnish service equipment, permits, certificates or rights of way as specified to be furnished as a condition of obtaining service.
- 7) for failure of the customer to permit the Company reasonable access to Company equipment.
- 8) for nonpayment of a bill, except as restricted by North Dakota Statutes or rules provided that the Company has made a reasonable attempt to effect collection and : (1) the Company has provided five days written notice to the Customer, except that disconnection may take place prior to the expiration of the 5-day notice period if the Company determines that usage during the 5-day notice period is so abnormally high that a risk of irreparable revenue loss is created; (2) the Company is prepared to reconnect the same day if disconnection is scheduled for a weekend, holiday or after 2 p.m.; (3) In the event of a dispute concerning a bill, the Company may required the customer to pay a sum of money equal to the amount of the undisputed portion of the bill.

2.21 Refusal of Telecommunications Service

The Company may refuse to furnish telecommunications service if it has reasonable cause to believe that the service will be used in violation of, or noncompliance with, any of the regulations or other conditions contained in this Tariff governing the furnishing of such service. If the Company so refuses to furnish service it will inform the applicant of their right to complain to the North Dakota Public Service Commission. If the Commission shall, upon hearing such complaint, determine that the service will not be used in violation of any of the regulations or other conditions contained in this Tariff, the service will be promptly furnished.

SECTION 2 - GENERAL REGULATIONS (CONT'D)

2.22 Special Construction

A. Property

- 1) An average amount of entrance and distribution facilities may be furnished by the Company, provided the facilities are of the standard type normally furnished for the particular location or kind of service.
- 2) If additional entrance or distribution facilities are required; if the conditions are such as to require special equipment, maintenance or methods of construction; if the stability of the customer has not been established; if the installation is for a temporary or semi-permanent purpose or if for any other reason the construction costs are excessive as compared with the revenue to be derived, the applicant shall be required to pay the costs over and above those applicable for a normal installation.
- 3) The customer will provide the Company without charge written permission for the placing of the Company's facilities on the property.

B. Underground

- 1) When feasible, conduit will be furnished by the Company at cost, or conduit may be provided by the applicant subject to the Company's specifications. Conduit used for Company facilities may not be used for any other purpose without the consent of the Company. The distance between the conduit and an electric light or power conduit or conductor shall be in accordance with the Company's specifications. The customer shall be required to pay the entire cost of maintenance of conduit including subsequent excavations and replacements necessary because of damage resulting from negligence on the part of the customer or the customer's representatives or from freezing or improper drainage.
- 2) The cost of relocating underground entrance facilities at the customer's request will be borne by the customer.

SECTION 2 - GENERAL REGULATIONS (CONT'D)

2.23 Special Assemblies of Equipment or Speculative Projects

- A. Special Assemblies of Equipment or Speculative Projects, for which provision is not otherwise made in this Tariff or those involving unusual costs, may be provided where practicable, if not detrimental to any of the telecommunications services furnished by the Company.
- 1) The charge for such facilities may be in the form of an installation charge, a monthly charge, a termination charge or any combination thereof, and will include, but not limited to, when applicable, one or more of the following estimated expense items associated with the special equipment or service provided:
 - a) Maintenance expense
 - b) Depreciation expense - including reusable and non-recoverable items
 - c) Administration expense
 - d) Taxes - including Federal Income Tax
 - e) Any other specific items of expense that may be associated with the facility provided
 - f) A reasonable return on investment
 - 2) The estimated installation cost used in the derivation of the various expense items shall include but not limited to, the following:
 - a) Material
 - b) Material overhead
 - c) Installation labor
 - d) Installation labor overhead
- B. In connection with Marketing and Sales studies or programs, the Company reserves the right to waive Service Charges within specified areas for such periods of time as designated by the Company and filed with the Commission if so required.

SECTION 2 - GENERAL REGULATIONS (CONT'D)

2.24 Adjustments for Municipality Payments

- A. If at any time a municipality acquires the legal right to impose an occupation tax, license tax, permit fee, franchise fee or other similar charge upon the Company and imposes the same by ordinance or otherwise, such taxes, fees or charges shall be billed to the customers receiving service within the territorial limits of such municipality. Such billing shall allocate the tax, fee or charge among customers uniformly on the basis of each customer's monthly charges for the types of service made subject to such tax, fee or charge.

SECTION 3 - SERVICE CONNECTION CHARGES

3.1. General

1. Service connection charges are those charges associated with work performed by the Telephone Company in connection with the provisions of service for a customer.
2. Service connection charges are in addition to any other scheduled rates and charges. They apply in addition to and not in lieu of non-recurring charges or construction charges.
3. The charges herein do not contemplate work being performed by Company employees at a time when overtime wages apply due to the request of the customer, nor do they contemplate work begun being interrupted by a customer. If the customer requests overtime labor to be performed or interrupts work once begun, a charge in addition to the specified charge will be made equal to the additional cost involved.
4. The charges do not include work related to the installation or repair of customer owned equipment or inside wiring.

SECTION 3 - SERVICE CONNECTION CHARGES (CONT'D)

3.2 Charges

- 1. Record Charge \$8.00

This charge includes the time and materials for the establishment of business office records and operator information records. Specifically, time involved in taking request, credit check, preparation and process of order, completing customer line card, completing customer information card and file folder, completing maintenance sheet, computer entries, as well as all work involved in modifying an existing record.

- 2. Central Office Connection Charge (Per Line) \$20.00

This charge will apply whenever work is required in Central Office. Includes time for frame wiring, testing, and routing of C.O.E., preparation or changes of associated records. This charge may be in addition to a new record change charge.

- 3. Service Connection Charge \$20.00

Apply to business premises for:

- Establishing Service;
- Reconnections or re-establishment of service;
- Move of service from one premise to another;
- Assumption of service with a change in responsibility or ownership.

This charge covers the time involved to install one average* complete outside circuit initiated by the request of a subscriber to provide an average telephone circuit in accordance with industry standards. This charge includes all materials, labor, and trenching equipment. This charge is in addition to the record change charge and the central office connection charge.

*Average is defined as 1000' of drop wire. If the installation exceeds the average length additional charges may also apply.

SECTION 3 - SERVICE CONNECTION CHARGES (CONT'D)

3.2 Charges, (Cont'd)

4. Dishonored Check Charge \$20.00

This charge applies when any negotiable instrument presented for payment of service or deposit becomes dishonored, and is returned to the Telephone Company from the bank.

5. Collection Charge \$30.00

Collection Charges Apply:

- a. When a trip is made to a premise for the purpose of disconnect and the customer who is delinquent in their account pays the statement at that point in time to save their service from disconnect.
- b. When a trip is necessary to a premise to make a collection of account or to collect cash to cover an NSF check by the Company in payment of service.

6. Trouble Isolation Charge

A nonrecurring charge will apply to each repair visit at a customer's request to test the central office line, up to the Demarcation Point, when the line test clear and the trouble is no found in Company facilities.

Rates: Per Repair Visit - Business Service \$27.00

SECTION 4 - SPECIAL ACCESS SERVICE

4.1 General

Special Access Service consists of any of the services offered hereunder, either individually or in combination. Each service is offered independently of all others.

4.2 Transmission Service

- A. Transmission Service is offered via Onvoy’s facilities for the transmission of one-way and two-way communications.
- B. Digital Channels over Onvoy’s Network are furnished for full-duplex transmission of digital signals at operating speeds as follows:

56.0	Kbps (DS-0)
1,544	Mbps (DS-1)
44.736	Mbps (DS-3)

Digital Channels operating at speeds other than those listed above may be provided at Onvoy’s option on an Individual Case Basis (ICB).

- C. Digital Channels furnished by Onvoy at 1.544 Mbps, interconnections to such Channels and equipment’s interfacing to such Channels shall meet the following characteristics:

Line Rate:	1.544 Mbps + 130 ppm
Line Code 1:	Bipolar (Alternate Mark) Inversion
Line Code 2:	Bipolar 8 zero substitution (B8ZS)
Line Impedance:	100 ohms + 5% balanced
Jitter:	The multiplexer will add not more than 0.3 time slot of rms jitter to a DS-1 signal when looped at the DS-3 point.

SECTION 4 - SPECIAL ACCESS SERVICE (CONT'D)

4.2 Transmission Service (Cont'd)

- D. Digital Channels furnished by Onvoy at 44.736 Mbps, interconnections to such Channels and equipment interfacing to such Channels shall meet the following technical characteristics:

Line Rate:	44.736 Mbps + 20 ppm
Line Code:	Bipolar with three-zero substitution (B3ZS)
Line Impedance:	75 ohms (+) 5 percent unbalanced

4.3 Special Access Rates

A. Special Construction

1. Basis for Rates and Charges

Rates and charges for special construction will be determined by Onvoy on an Individual Case Basis and based, in part, on the costs incurred by Onvoy and may include (1) non-recurring type charges, (2) recurring type charges, (3) termination liabilities, or (4) combinations thereof.

2. Termination Liability

To the extent that there is no other requirement for use by Onvoy, a termination liability may apply for facilities specially constructed at the request of the Customer.

- a. The termination liability period is the initial service term with respect to said specially constructed facilities.
- b. The amount of the maximum termination liability is equal to the rates and charges for the initial service term prorated for the unexpired period of liability.

SECTION 4 - SPECIAL ACCESS SERVICE (CONT'D)

4.3 Special Access Rates (Cont'd)

B. Rate Elements

1. General

Rates are composed of three elements which may apply to a Customer's service, depending upon the specific service requested and its location.

- a. The Channel termination rate element provides for the termination of the communications path at the Customer designated location. One Channel termination charge applies for each Customer designated location at which a Channel is terminated.
- b. The Channel mileage rate elements are determined by the Vertical and Horizontal Coordinates ("V&H") method, as set forth on the National Exchange Carrier Association Tariff, F.C.C. No. 4. When the calculation results in a fraction of a mile, the total is rounded up to the next whole mile before applying the rate.
- c. Optional Features for which charges are applied only if ordered.

SECTION 4 - SPECIAL ACCESS SERVICE (CONT'D)

4.3 Special Access Rates (Cont'd)

C. DS-1 Service

DS-1 Service is a digital transmission facility of 1.544 Mbps with a capacity of up to 24 analog or digital Channels. This service supports voice, analog data, digital data, and video.

1. This service consists of making DS-1 capacity available on a dedicated access basis.

2.	DS-1 Rates	<u>NRC</u>	<u>Monthly Rate</u>
a.	Channel Termination	ICB	ICB
b.	Channel Mileage Termination		ICB
c.	Channel Mileage Facility		ICB
d.	Multiplexing DS-1 to Voice		ICB

D. DS-3 Service

DS-3 Service is a digital transmission facility of 44.736 Mbps with a capacity of 28 DS-1 Channels or 672 Voice, Analog Data or Digital Data Channels.

1. This service consists of making DS-3 capacity available on a dedicated access basis.

2.	DS-3 Rates	<u>NRC</u>	<u>Monthly Rate</u>
a.	Channel Termination	ICB	ICB
b.	Channel Mileage Termination		ICB
c.	Channel Mileage Facility		ICB
d.	Multiplexing DS-3 to DS-1		ICB

SECTION 4 - SPECIAL ACCESS SERVICE (CONT'D)

4.4 Service Calls

When a Customer reports trouble to Onvoy for clearance and no trouble is found in Onvoy's facilities, the Customer may be responsible for payment of a charge calculated from the time Onvoy personnel are dispatched to the Customer Premise until the work is completed.

Service Call Charge Rates

Basic	\$15.00/ ½ hr.
Overtime	\$20.00/ ½ hr.
Premium	\$25.00/ ½ hr.

Basic rates apply Monday through Friday, 8:00 A.M. - 5:00 P.M. Overtime rates apply evenings and premium rates apply weekends and holidays.

4.5 Individual Case Basis Arrangements

When Onvoy furnishes a facility or service for which a rate or charge is not specified in Onvoy's tariff, charges will be determined on an Individual Case Basis. Specialized rates or charges will be made available to similarly situated Customers on a nondiscriminatory basis.

SECTION 5 - SWITCHED ACCESS SERVICE

5.1 General

Switched Access Service, which is available to IXC Customers for their use in furnishing their services to End Users, provides a two-point communications path between a Customer's Premises and an End User's Premises. It provides for the use of common terminating, switching and transport facilities. Switched Access Service provides the ability to originate calls from an End User's Premises to a Customer's Premises, and to terminate calls from a Customer's Premises location to an End User's Premises.

Switched Access Service is generally comprised of Switched Access Local Service and Switched Access Tandem Service. Switched Access Tandem Service provides for access tandem and transport service between participating local exchange carriers (LECs) and IXC customers. Switched Access Tandem Service provides for originating (from LEC to IXC) and terminating (from IXC to LEC) traffic.

5.2 Provision and Description of Switched Access Service Arrangements

Switched Access Service is provided in the following service type:

A. Equal Access Feature Group D (FGD) Access

Equal Access FGD Access, which is available to all Customers, is provisioned at the DS1 and DS3 level and provides trunk-side access to Onvoy Access Tandem switches.

The default LEC arrangement is that all LECs (and CLECs) connected to Onvoy provide Equal Access at the LEC level, enabling all end users to be "presubscribed" to the end user's choice of IXC. No Access Codes are required for calls to a Customer over FGD Switched Access Service if the End User's telephone exchange service is provisioned for Equal Access.

Basic FGD service will be provided with SS7 Signaling. Where Equal Access is provisioned by the LEC, the number dialed by the Customer's End User shall be a seven or ten digit number for calls in the North American Numbering Plan (NANP), except for 00-dialed calls which are routed to the predesignated Customer. For international calls outside the NANP, a seven to twelve digit number may be dialed. The form of the numbers dialed by the Customer's End User is NXX-XXXX, 0 or 1 + NXX-XXXX, NPA + NXX-XXX, 0 or 1 + NPA + NXX-XXXX, and, when the Local Switching Center equipped for International Direct Distance Dialing (IDDD), 01 + CC + NN or 011 + CC + NN.

SECTION 5 - SWITCHED ACCESS SERVICE (CONT'D)

5.2 Provision and Description of Switched Access Service Arrangements (Cont'd)

B. Dial-Around ("Casual") Feature Group D (FGD) Access

The LEC/CLEC also provides for Dial-Around or "casual" dialing of alternative long distance carriers enabling the use of an alternative Access Code, where available, for the Customer's use in originating and terminating communications. The Dial-Around Access Code for FGD switching is a uniform Access Code of the form 10XXX or 101XXXX, where XXX or XXXX is assigned to the Customer by North American Numbering Plan Administration (NANPA). A single Access Code will be the assigned number of all FGD access provided to the Customer by Onvoy. For Dial-Around Access, the dialing pattern will be 10XXX+NXX-XXXX or 10XXX+NPA+NXX-XXXX, or substituting the longer 101XXXX Access Code in lieu of 10XXX with the required NXX-XXXX or NPA+NXX-XXXX.

C. Trunk Configuration

Trunks used for Switched Access Service may be configured for one-way (either originating only or terminating only) or for two-way directionality. It is the Customer's responsibility to order a sufficient number of trunks of each type in order to meet its desired grade of service objective. At the Customer's request, Onvoy will assist the Customer in sizing Switched Access Trunk groups.

D. Rate Categories

The following rate categories apply to Switched Access Service:

1. Local Switching Charge: Provides for the use of the local end office switching, end user line termination and intercept functions.
2. 800 Data Base Access Service

800 Data Base Access Service is a service offering utilizing originating Trunk side Switched Access Service. When an 800 + NXX + XXXX call is originated by an End User, Onvoy will perform Customer identification based on screening of the full ten-digits of the 800 number to determine the Customer location to which the call is to be routed.

SECTION 5 - SWITCHED ACCESS SERVICE (CONT'D)

5.2 Provision and Description of Switched Access Service Arrangements (Cont'd)

D. Rate Categories, (Cont;d)

3. Tandem Switching

The following services comprise Switched Access Tandem Service and unless otherwise noted, are applied on a per minute-of-use basis:

Usage (Traffic Sensitive) Services

- a.) Tandem Switching: Tandem Switching is assessed for utilizing tandem switching functions when tandem routing is requested for trunk side services. The company will provide originating and terminating tandem switching services.

Delivery of calls to, or acceptance of calls from, the Customer via the Company access tandem shall constitute a constructive order and an agreement by the Customer to purchase the Company's switched access tandem services as described herein.

- b.) Tandem Transport: Tandem Transport is composed of a "Tandem Switched Transport Termination" rate and a "Tandem Switched Transport Facility" rate. Both rate elements apply for each Transmission Path used by the Customer. A Transmission Path is defined as the Company's transport facility between the access tandem and a POI. The "Tandem Switched Transport Termination" rate provides for the circuit equipment at the end of the transmission facilities. The "Tandem Switched Transport Facility" rate provides for the transmission facilities, including intermediate transmission circuit equipment between the end points of the interoffice circuit.

SECTION 5 - SWITCHED ACCESS SERVICE (CONT'D)

Tandem Switched Transport charges apply for each transmission path utilized by the Customer on the trunk side of the Company access tandem. A Customer's point of interconnection may be located at Onvoy's access tandem or at a Company POI.

When a Customer's point of interconnection is located at a Company access tandem location, then one rate of Tandem Switched Transport Termination and one rate of Tandem Switched Transport Facility apply per MOU.

Tandem Transport with One Transport Transmission Path

Tandem Switching applies for MOU
switched thru Access Tandem

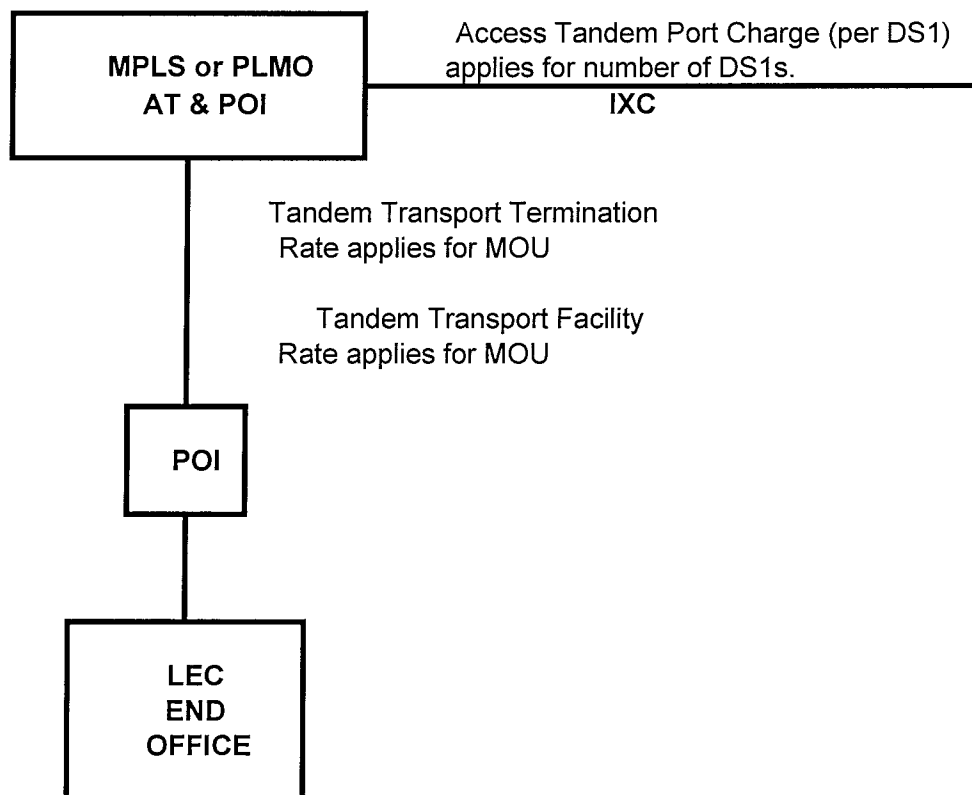

SECTION 5 - SWITCHED ACCESS SERVICE (CONT'D)

When a Customer's point of interconnection is located at a Company POI not collocated with a Company access tandem, then two rates of Tandem Transport Termination and two rates of Tandem Transport Facility apply per MOU.

Tandem Transport with Two Transport Transmission Paths

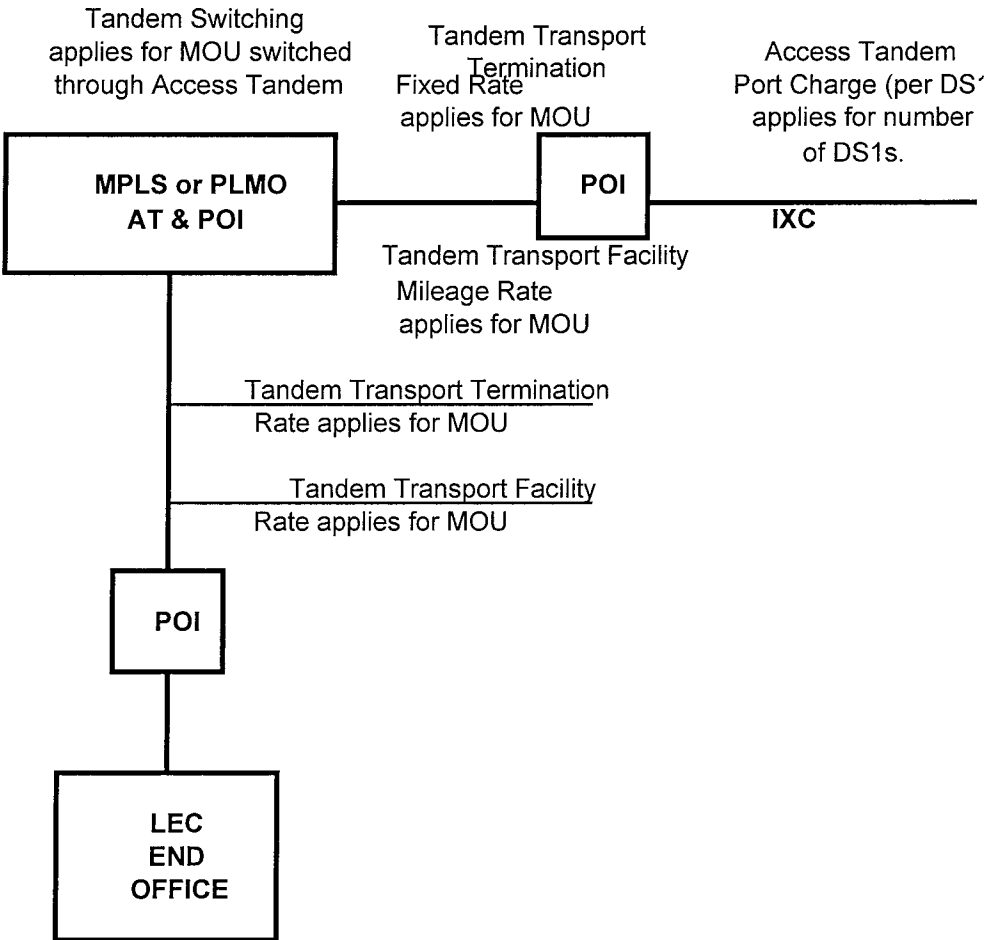

SECTION 5 - SWITCHED ACCESS SERVICE (CONT'D)

5.2 Provision and Description of Switched Access Service Arrangements (Cont'd)

D. Rate Categories, (Cont;d)

4. Port Services

Access Tandem DS1 Port Charge: An access tandem DS1 port is provided for each DS1 trunk terminated on the trunk side of the access tandem when the customer has requested tandem routing. The Access Tandem Port Charge is assessed monthly per DS1 trunk.

5. Switched Access Service Optional Features

- a.) Non-chargeable Optional Features: Where transmission facilities permit, Onvoy will, at the option of the Customer, provide the following non-chargeable optional feature in association with Switched Access Service.

Acceptance Testing: At no additional charge, Onvoy will, at the Customer's request, cooperatively test, at the time of installation, the following parameters: loss, C-notched noise, C-message noise, 3-tone slope, d.c. continuity and operational signaling.

Ordering Options and Conditions: Access Service is ordered under the Access Order provisions set forth in Section 6. Also included in that section are other charges, which may be associated with ordering Switched Access Service.

Competitive Pricing Arrangements: Competitive pricing arrangements for Local Transport-Entrance Facilities and Local Transport-Direct Trunked transport can be furnished to meet the communication needs of specific customers on a case by case basis under individual contract.

SECTION 5 - SWITCHED ACCESS SERVICE (CONT'D)

5.3 Obligations of Onvoy

In addition to the obligations of Onvoy set forth in other sections of this tariff, Onvoy has certain other obligations concerning the provisions of Switched Access Service. These obligations are as follows:

A. Network Management

Onvoy will administer its Network to ensure the provision of acceptable service levels to all telecommunications users of Onvoy's Network Services. Generally, service levels are considered acceptable only when both End Users and Customers are able to establish connections with little or no delay encountered within Onvoy Network. Onvoy reserves the right to apply protective controls, (i.e., those actions, such as call gapping, which selectively cancel the completion of traffic), over any traffic carried over its Network, including that associated with a Customer's Switched Access Service. Generally, such protective measures would only be taken as a result of occurrences such as failure or overload of Onvoy or Customer facilities, natural disasters, mass calling or national security demands. The Customer will notify Onvoy of anticipated peaked services as stated below. Based on the information provided, Onvoy will work cooperatively with the Customer to determine the appropriate level of control. In the event that the protective controls applied by Onvoy result in the complete loss of service by the Customer, the Customer will be granted a credit allowance for service interruption as set forth in Section 16.

When a Customer uses Onvoy's facilities to offer services for which a substantial call volume or peaked service is expected during a short period of time, the Customer must notify Onvoy at least 24 hours in advance of each peak period. For events scheduled during weekend or holidays Onvoy must be notified no later than 5:00 p.m. local time on the prior business day. Notification should include the nature, time, duration and frequency of the event, an estimated call volume, and the NPA NXX and line number(s) to be used. On the basis of the information provided, Onvoy may invoke network management controls if required to reduce the probability of excessive Network congestion. Onvoy will work cooperatively with the Customer to determine the appropriate level of such control. Failure to provide prescribed notification may result in Customer caused Network congestion, which could result in discontinuance of service and/or damages.

SECTION 5 - SWITCHED ACCESS SERVICE (CONT'D)

5.4 Obligations of the Customer

In addition to obligations specified elsewhere in this tariff, the Customer has certain specific obligations pertaining to the use of Switched Access Service, as follows:

- A. Report Requirements: When a Customer orders Switched Access Service for both interstate and intrastate use, the Customer is responsible for providing Jurisdictional Reports. Charges will be apportioned in accordance with those reports.
- B. Supervisory Signaling: The Customer's facilities at the premises of the ordering Customer shall provide the necessary On-Hook, Off-Hook answer and disconnect supervision.
- C. Design of Switched Access Services: It is the Customer's responsibility to assure that sufficient Access Services have been ordered to handle its traffic.

5.5 Switched Access Rates

There are three types of rates and charges that apply to Switched Access Service. These are Monthly Recurring Charges, Usage Rates and Non-Recurring Charges.

- A. Monthly Recurring Charges: Monthly Recurring Charges are flat rates for facilities that apply each month or fraction thereof that a specific rate element is provided.
- B. Usage Rates: Usage rates are rates that are applied on a per access minute, per access line or per query basis. Usage rates are accumulated over a monthly period.
- C. Non-Recurring Charges: Non-Recurring charges are one time charges that apply for a specific work activity (i.e., installation of new service or change to an existing service).

SECTION 5 - SWITCHED ACCESS SERVICE (CONT'D)

5.6 Billing of Access Minutes:

When recording originating calls over FGD with SS7 signaling, usage measurement begins with the transmission of the initial address message by the switch for direct Trunk groups and with the receipt of an exit message by the switch for tandem Trunk groups. The measurement of originating FGD usage ends when the entry switch receives or sends a release message, whichever occurs first.

For terminating calls over FGD with SS7 signaling, the measurement of access minutes begins when the terminating recording switch receives the initial address message from the terminating End User. On directly routed Trunk groups or on tandem routed Trunk groups, Onvoy switch receives the initial address message and sends the indication to the Customer in the form of an answer message. The measurement of terminating FGD call usage ends when the entry switch receives or sends a release message, whichever occurs first.

5.7 Voice Over Internet Protocol – Public Switched Telephone Network (“VoIP -PSTN”) Traffic

- A. This section governs the identification and treatment of VoIP-PSTN Traffic that is required to be compensated at interstate access rates unless the parties have agreed otherwise in a written agreement. Specifically, this section establishes the method of separating such traffic (referred to in this tariff as “Relevant VoIP-PSTN traffic”) from a Customer’s traditional intrastate access tariff, so that such Relevant VoIP-PSTN traffic can be billed in accordance with the FCC Order.
- B. Company will bill and collect the full Access Reciprocal Compensation on traffic exchanged with Customers when such traffic originates and/or terminates in Internet Protocol format, as set forth in Section 51.913 of the Federal Communications Commission’s rules, 47 C.F.R. §51.913, regardless of whether the Company itself delivers such traffic to the called party’s premises or the call is delivered to the called party’s premises by an affiliated or unaffiliated provider of interconnected Voice over Internet Protocol service or a non-interconnected Voice Over Internet Protocol service that does not itself seek to collect Access Reciprocal Compensations for this traffic.¹

Intrastate VoIP – PSTN traffic is subject to the Company’s applicable interstate switched access rate per minute, as set forth in the Company’s F.C.C. Tariff No. 1.

¹. See, *In the Matter of Connect America Fund A National Broadband Plan for Our Future Establishing Just and Reasonable Rates for Local Exchange Carriers High-Cost Universal Service Support Developing an Unified Intercarrier Compensation Regime Federal-State Joint Board on Universal Service Lifeline and Link-Up Universal Service Reform – Mobility Fund*, Report and Order and Further Notice of Proposed Rulemaking, Docket Nos. WC Docket No. 10-90, *et al.*, FCC 11-161, (Rel. November 18, 2011).

SECTION 5 - SWITCHED ACCESS SERVICE (CONT'D)

5.7 Voice Over Internet Protocol – Public Switched Telephone Network (“VoIP -PSTN”) Traffic, (Cont’d)

C. Calculations and Application of Percent VoIP-PSTN Usage

Company will determine the number of Relevant VoIP-PSTN Traffic minutes of use (“MOU”) to which interstate rates will be applied under subsection 5.7.A, above, by applying a Percent VoIP Usage (“PVU”) factor to the total intrastate access MOU exchanged between a Company End User and the Customer. The PVU will be derived and applied as follows.

1. The Customer will calculate and furnish to Company a factor (the “PVU-A”) representing the percentage of the total intrastate and interstate access MOU that the Customer exchanges with Company in the State, that (a) is sent to Company and that originated in IP format; or (b) is received from Company and terminated in IP format. This PVU-A shall be based on information such as the number of the Customer’s retail VoIP subscriptions in the state (e.g., as reported on FCC Form 477), traffic studies, actual call detail, or other relevant and verifiable information.
2. Company will use the PVU-A and PVU-B factors to calculate a PVU factor that represents the percentage of total intrastate and interstate access MOU exchanged between a Company End User and the Customer that is originated or terminated in IP format, whether at Company’s end, at the Customer’s end, or at both ends. The PVU factor will be calculated as the sum of: (A) the PVU-A factor and (B) the PVU-B factor times (1.0 minus the PVU-A factor).

SECTION 5 - SWITCHED ACCESS SERVICE (CONT'D)

5.7 Voice Over Internet Protocol – Public Switched Telephone Network (“VoIP -PSTN”) Traffic, (Cont’d)

C. Calculations and Application of Percent VoIP-PSTN Usage (Cont’d)

3. Company will similarly calculate a factor (the “PVU-B”) representing the percentage of Company’s total intrastate and interstate access MOU in the State that Company originates or terminates on its network in IP format. This PVU-B shall be based on information such as the number of Company’s retail VoIP subscriptions in the state (e.g., as reported on FCC Form 477), traffic studies, actual call detail, or other relevant and verifiable information.
4. Company will use the PVU-A and PVU-B factors to calculate a PVU factor that represents the percentage of total intrastate and interstate access MOU exchanged between a Company End User and the Customer that is originated or terminated in IP format, whether at Company’s end, at the Customer’s end, or at both ends. The PVU factor will be calculated as the sum of: (A) the PVU-A factor and (B) the PVU-B factor times (1.0 minus the PVU-A factor).
5. Company will apply the PVU factor to the total intrastate access MOU exchanged with the Customer to determine the number of Relevant VoIP-PSTN Traffic MOUs.

Example 1: The PVU-B is 10% and the PVU-A is 40%. The PVU factor is equal to $40\% + (10\% \times 60\%) = 46\%$. Company will bill 46% of the Customer’s intrastate access MOU at its applicable tariffed interstate rates.

Example 2: The PVU-B is 10% and the PVU-A is 0%. The PVU factor is $0\% + (100\% \times 10\%) = 10\%$. Company will bill 10% of the Customer’s intrastate access MOU at Company’s applicable tariffed interstate switched access rates.

Example 3: The PVU-A is 100%. No matter what the PVU-B factor is, the PVU is 100%. Company will bill 100% of the Customer’s intrastate access MOU at Company’s applicable tariffed interstate switched access rates.

6. If the Customer does not furnish Company with a PVU factor, the Company will utilize a PVU-a factor of zero.

SECTION 5 - SWITCHED ACCESS SERVICE (CONT'D)

5.7 Voice Over Internet Protocol – Public Switched Telephone Network (“VoIP -PSTN”) Traffic, (Cont’d)

D. Initial PVU Factor

If the PVU factor is not available and/or cannot be implemented in Company’s billing systems by April 15, 2012, the Company will adjust the Customer’s bills to reflect a PVU of zero retroactively to January 1, 2012.

E. PVU Factor Updates

The Customer may update the PVU-A factor quarterly. The Customer shall submit such update no later than the 15th day of January, April, July, and October of each year. Revised PVU factors must be based on the data for the prior three months ending the last day of December, March, June, and September respectively. The Company will use the revised PVU-A factor to calculate a revised PVU. The revised PVU will be used for future billing and will be effective on the bid date of each month and will be used for subsequent monthly billing until superseded by a new PVU factor. No prorating or back billing will be done based on the updated PVU factors. The PVU factor will be billed beginning on January 1, 2012.

F. PVU Factor Verification

Not more than twice in any year, Company may ask the Customer to verify the PVU-A factor furnished to Company and a Customer may ask Company to verify the PVU-B factor and the calculation of the PVU factor. The party so requested shall comply, and shall reasonably provide the records and other information used to determine the respective PVU-A and PVU-B factors.

SECTION 5 - SWITCHED ACCESS SERVICE (CONT'D)

5.8 Rates and Charges

	<u>Rate</u>
A. Local Switching Charge	
1. Local Switching	
a. originating per minute of use	\$.010000
b. terminating per minute of use	Note 1
B. Tandem Switching Charge:	
Originating, per minute of use	\$.005734
Terminating, per minute of use	
C. Tandem Switched Transport Termination:	
Originating, per minute of use	\$.000545
Terminating, per minute of use	Note 1
D. Tandem Switched Transport Facility, per minute of use	
Originating, per minute of use	\$.000750
Terminating, per minute of use	Note 1
E. 800 Database query charge: for basic or vertical queries	\$0.004053

Note 1: See the Company's Access Services Tariff FCC No. 1 at the following link <https://apps.fcc.gov/etfs/public/lecTariffs.action?idLec=242>.

SECTION 6 - ORDERING OPTIONS FOR SWITCHED AND SPECIAL ACCESS SERVICE

6.1 General

A. Ordering Conditions

All services offered under this section may be ordered using an ASR. The format and terms of the ASR will be as specified in the industry Access Service Order Guidelines, unless otherwise specified herein. A Customer may order any number of services of the same type and between the same Premises on a single ASR. All details for services for a particular order must be identical.

The Customer may also constructively order services by routing traffic to the Company, or accepting traffic from the Company, through the tandem of another local exchange carrier to which the Customer is connected (the "tandem provider"). Where the Customer orders service via this option, the Company may use information provided to the Company by the tandem provider or information obtained from other sources to bill the Customer for the services provided.

The Customer shall provide all information necessary for Onvoy to provide and bill for the requested service. When placing an order for Access Service, the Customer shall provide the following minimum information:

- Customer name and Premise(s) address (es);
- Billing name and address (when different from Customer name and address)
- Customer contact name(s) and telephone number(s) for the following provisioning activities: order negotiation, order confirmation, interactive design, installation and billing.

The order date (Application Date) is the date on which Onvoy receives a firm commitment and sufficient information from the Customer to allow processing of the ASR. The Customer is advised of the critical events in the provisioning process, the Application Date, the Plant Test Date and the Service Commencement Date at the time Onvoy gives the Customer a Firm Order Confirmation (FOC). The FOC is forwarded to the Customer within two business days after the date on which all information needed to process the ASR has been received by Onvoy.

SECTION 6-ORDERING OPTIONS FOR SWITCHED AND SPECIAL ACCESS SERVICE (CONT'D)

6.1 General

B. Provision of Other Services

With the agreement of Onvoy, other services may subsequently be added to the ASR at any time, up to and including the service date for the Access Service. When added subsequently, charges for a Design Change as set forth in subsection E and will apply when an engineering review is required.

Additional Engineering is not an ordering option, but will be applied to an ASR when Onvoy determines that Additional Engineering is necessary to accommodate a Customer request. Additional Engineering will be provided by Onvoy at the request of the Customer only when a Customer requests additional technical information after Onvoy has already provided the technical information included on the Design Layout Report as set forth herein. The Customer will be notified when Additional Engineering is required, and will be furnished with a written statement setting forth the justification for the Additional Engineering as well as an estimate of the charges. If the Customer agrees to the Additional Engineering, a firm order will be established. If the Customer does not want the service or facilities after being notified by Onvoy that Additional Engineering is required, the Customer may cancel the order and no charges will apply. Once a firm order has been established, the total charge to the Customer for the Additional Engineering may not exceed the original estimated amount by more than 10 percent.

SECTION 6-ORDERING OPTIONS FOR SWITCHED AND SPECIAL ACCESS SERVICE (CONT'D)

6.2 Access Order

When a Customer requests new or additional Switched Access Service, one or more ASR's may be required. The number of orders required is dependent on the type of services and/or facilities being requested.

A. Access Service Date Intervals: Access Service is provided with one of the following Service Date intervals:

- Standard Interval
- Negotiated Interval

Onvoy will specify a FOC and the Service Commencement Date contingent on the ASR being complete as received. To the extent the Access Service can be made available with reasonable effort; Onvoy will provide the Access Service in accordance with the Customer's requested interval, subject to the following conditions:

1. Standard Interval: The Standard Interval for Switched and Special Access Service will be ten business days from the Application Date. This interval only applies to standard service offerings for a Customer, which is On-Net, and at locations where there are pre-existing facilities to the Customer Premises. Access Services provided under the Standard Interval will be installed during Company business hours.

SECTION 6-ORDERING OPTIONS FOR SWITCHED AND SPECIAL ACCESS SERVICE (CONT'D)

6.2 Access Order (Cont'd)

A. Access Service Date Intervals: (Cont'd)

2. Negotiated Interval: Onvoy will negotiate a Service Date interval with the Customer when:
 - a.) The Customer requests a Service Date before or beyond the applicable Standard Interval Service Date; or
 - b.) There is no existing facility connecting the Customer Premises with Onvoy; or
 - c.) The Customer requests a service that is not considered by Onvoy to be a standard service offering (for example, if Additional Engineering is required to complete the order); or
 - d.) Onvoy determines that Access Service cannot be installed within the Standard Interval.

Onvoy will offer a Service Date based on the type and quantity of Access Services the Customer has requested. The Negotiated Interval may not exceed by more than six months the Standard Interval Service Date, or, when there is no Standard Interval, Onvoy offered Service Date.

All services for which rates are applied on an Individual Case Basis are provided with a Negotiated Interval.

SECTION 6-ORDERING OPTIONS FOR SWITCHED AND SPECIAL ACCESS SERVICE (CONT'D)

6.2 Access Order (Cont'd)

- B. Access Service Request Modifications: The Customer may request a modification of its ASR prior to the Service Commencement Date. All modifications must be in writing using the industry ASR process. Onvoy, in its sole discretion, may accept a verbal modification from the Customer. Onvoy will make every effort to accommodate a requested modification when it is able to do so with the normal work force assigned to complete such an order within normal business hours. Charges for access service order modification will apply as set forth below, on a per occurrence basis.

Any increase in the number of Special Access Service Channels, Switched Access Services lines, Trunks, Direct Connect transport facilities, Out of Band Signaling connections or any change in engineering or functionality of a service will be treated as a new ASR with a new Service Date interval.

1. Service Commencement Date Changes: ASR service dates for the installation of new services or rearrangement of existing services may be changed, but the new service date may not exceed the original Service Commencement Date by more than 30 calendar days. When, for any reason, the Customer indicates that service cannot be accepted for a period not to exceed 30 calendar days, and Onvoy accordingly delays the start of service, a Service Date Change Charge will apply. In addition, when the Customer submits a request for a Service Date Change that is less than five business days from the date of notification by the Customer, a Service Date Change Charge and an Expedite Charge will apply. No Expedite Charges will apply if the Customer requests a Service Date Change that is more than five business days from the date of request by the Customer but earlier than the original requested Service Commencement Date.

If the Customer requested service date is more than 30 calendar days after the original service date, the order will be canceled by Onvoy on the 31st day. Appropriate cancellation charges will be applied. If the Customer still requires the service, the Customer must place a new ASR with Onvoy.

The Service Date Change Charge will apply on a per order, per occurrence basis for each service date changed. The applicable charges are set forth under subsection E.

SECTION 6-ORDERING OPTIONS FOR SWITCHED AND SPECIAL ACCESS SERVICE (CONT'D)

6.2 Access Order (Cont'd)

B. Access Service Request Modifications: (Cont'd)

2. Design Change Charge: The Customer may request a Design Change to the service ordered. A Design Change is any change to an ASR which requires Engineering Review. An Engineering Review is a review by Company personnel of the service ordered and the requested changes to determine what change(s) in the design, if any, are necessary to meet the Customer's request. Design Changes include such changes as the addition or deletion of optional features or functions, a change in the type of Transport Termination (Switched Access only) or type of Channel interface. Any other changes are not considered Design Changes for purpose of this subsection and will require issuance of a new ASR and the cancellation of the original ASR with appropriate cancellation charges applied. The Design Change Charge will apply on a per order, per occurrence basis, for each order requiring a Design Change. The applicable charges are as set forth under subsection E and are in addition to any Service Date Change Charges that may apply.
3. Expedited Order Charge: When placing an Access Order for service(s) for which a Standard Interval exists, a Customer may request a Service Commencement Date that is earlier than the Standard Interval Service date, in which case an Expedite Charge will apply. The Expedite Charge will not apply if the new Service Commencement Date is more than five days from the date of the request to Onvoy of the expedited order request. The request for an earlier service date may be received from the Customer prior to its issuance of an ASR, or after the ASR has been issued but prior to the service date. Onvoy has the exclusive right to accept or deny the Expedite Order request. However if, upon reviewing availability of equipment and scheduled work load, Onvoy agrees to provide service on an expedited basis and the Customer accepts Onvoy's proposal, an Expedite Charge will apply.

SECTION 6-ORDERING OPTIONS FOR SWITCHED AND SPECIAL ACCESS SERVICE (CONT'D)

6.2 Access Order (Cont'd)

B. Access Service Request Modifications: (Cont'd)

3. Expedited Order Charge: (Cont'd)

If Onvoy is subsequently unable to meet an agreed upon expedited service date, then the Expedite Charge will not apply.

In the event Onvoy provides service on an expedited basis on the Customer's request, and the Customer delays service or is not ready for delivery of service at the time of installation, a Service Date Change Charge will apply in addition to the Expedite Charge.

In the event that the Customer cancels an expedite request, the Expedite Charge will be added to any applicable Cancellation Charge specified herein.

In the event that the Customer requests a Service Date Change after Onvoy has received the original expedite request, the Expedite Charge will still apply.

An Expedite Charge will not be applied to orders expedited for Company reasons.

If costs other than additional administrative expenses are to be incurred when the Access Order is expedited, the regulations and charges for Special Construction as set forth in this tariff will apply.

The Expedited Order Charge will apply on a per order, per occurrence basis, as specified in subsection E.

SECTION 6-ORDERING OPTIONS FOR SWITCHED AND SPECIAL ACCESS SERVICE (CONT'D)

6.2 Access Order (Cont'd)

C. Cancellation of an Access Service Request

A Customer may cancel an ASR for the installation of Switched Access Service at any time prior to notification by Onvoy that service is available for the Customer's use. The cancellation date is the date Onvoy receives written or verbal notice from the Customer that the order is to be canceled. The verbal notice must be followed by written confirmation within ten days. A Customer may negotiate an extension of a service date of an ASR for installation of new services or rearrangement of existing service, in which case a Service Date Change Charge will apply. However, the new service date cannot exceed the originally established service date by more than 30 calendar days. On the 31st day beyond the original service date, the ASR will be canceled and the appropriate Cancellation Charge will be applied.

Except as stated herein, Cancellation Charges will apply as specified in subsection E.

If the cancellation occurs prior to Onvoy's receiving the ASR, no charges shall apply.

A Customer may cancel an ASR for the installation of Special Access Service without incurring a charge at any time prior to the acceptance of a Negotiated Interval Service Date by the Customer. Cancellation Charges will apply for Special Access Service if the Customer cancels more than 48 hours after the Application Date. Cancellation Charges for Expedited Orders will be applied for any order canceled from the Application Date forward.

If Onvoy misses a service date for standard or Negotiated Interval Access Order by more than 30 days due to circumstances such as acts of God, governmental requirements, work stoppages and civil commotions, Onvoy shall not be liable for such delay and the Customer may cancel the ASR without incurring cancellation charges.

SECTION 6-ORDERING OPTIONS FOR SWITCHED AND SPECIAL ACCESS SERVICE (CONT'D)

6.2 Access Order (Cont'd)

D. Minimum Period of Service: The minimum period for which Access Service is provided and for which charges are applicable is one month.

1. The following changes will be treated as a discontinuance of the existing service and a request for installation of a new service. All associated Non-Recurring Charges will apply for the new service and a new minimum period will be established:

- a.) A change in the identity of the Customer of record;
- b.) A move by the Customer to a different building;
- c.) A change in type of service;
- d.) A change in Switched Access Service Interface (i.e., DS1 or DS3);
- e.) A change in Switched Access Service Traffic Type;
- f.) A change in type of Special Access Service Channel Termination;

2. When Access Service is disconnected prior to the expiration of the minimum period, charges are applicable for the balance of the minimum period. The Minimum Period Charge for monthly billed services will be determined as follows:

For Switched Access Service, the charge for a month or fraction thereof is the applicable minimum monthly charge for the capacity made available to the Customer.

For Special Access Service facilities, the charge for a month or fraction thereof is the applicable monthly charge for the service as set forth in this tariff.

All applicable Non-Recurring Charges for the service will be billed in addition to the Minimum Period Charge.

SECTION 6-ORDERING OPTIONS FOR SWITCHED AND SPECIAL ACCESS SERVICE (CONT'D)

6.2 Access Order (Cont'd)

E. Charges

	<u>Nonrecurring Charges</u>
1. Access Order Charge	\$89.00
2. Service Date Change Charge	\$100.00
3. Design Change Charge	\$100.00
4. Expedited Order Charge	\$114.00
5. Cancellation Charge	\$50.00
6. Miscellaneous Service Order Charge	\$50.00