

# STORMWATER POLLUTION PREVENTION PLAN



Hess Bakken Investments II, LLC  
3015 16<sup>th</sup> St. SW, Suite 20  
Minot, ND 58701

## North Dakota Construction Operations

---

In compliance with Permit No. NDR10-0000, Authorization to Discharge under the  
North Dakota Pollutant Discharge Elimination System

Date of Last Revision:  
January 8, 2016



## INTRODUCTION

All facilities covered by the North Dakota Pollutant Discharge Elimination System Permit associated with stormwater discharges from construction activity, NDR10-0000, shall prepare and implement a Storm Water Pollution Prevention Plan (SWPPP) prior to beginning any construction requiring the permit. The SWPPP and revisions are subject to review by the North Dakota Department of Health (NDDOH). The objectives of the plan are to identify potential sources of sediment or other pollution from construction activity and to ensure practices are used to reduce the contamination of pollutants from construction site runoff.

This document represents Hess Bakken Investments II, LLC's (HBIC II) Master North Dakota Construction SWPPP, as required by NDR10-0000. This SWPPP establishes a program by which sediments and other potential pollutant impacts to receiving waters from construction activities can be substantially reduced or eliminated. Each site covered by this SWPPP varies in location and layout but has a similar construction process. The common information and guidelines provided in this Master SWPPP will apply to well sites and pipelines in several fields. Specific information unique to each site will be entered into a database that is continuously updated.

Hess North Dakota Pipelines LLC (ND Pipelines) and Hess Tioga Gas Plant LLC (TGP), affiliates of HBIC II, also operate under this SWPPP pursuant to certain shared services and agency agreements with its affiliates. HBIC II is responsible for reclamation on ND Pipelines' and TGPs' pipeline projects. HBIC II is responsible for reclamation on well site projects and is ultimately responsible for this SWPPP.

This Construction Master SWPPP includes guidelines for:

- Determining whether permit coverage is required, and what storm water discharges are not covered
- Obtaining NDR10-0000 coverage and authorization
- Site inspection and documentation requirements
- Terminating NDR10-0000 coverage
- SWPPP plan review, revisions, and records guidelines

## GUIDELINES FOR COMPLIANCE

### Is Coverage Required

NDR10-0000 and applies to all areas within the jurisdiction of North Dakota. It applies to storm water discharges associated with large and small construction activities as defined in NDR10--0000 part I.A.2a & 2b, respectively. It also applies to storm water discharges from support activities related to construction sites such as concrete or asphalt batch plants, equipment staging yards, material storage areas, excavated material disposal areas, and embankment material borrow areas. Presently, NDR10-000 applies to oil & gas facilities which discharge contaminated storm water.

Storm water discharges that will not be covered under permit NDR10-0000 include:

- Storm water discharges associated with industrial facilities from any source other than construction activities
- Post construction discharges from industrial activity that happen after final stabilization is achieved
- The placement of fill into waters of the state requiring local, state, or federal authorizations
- Discharges to waters with a total maximum daily load (TMDL) allocation, are not covered unless you develop a SWPPP consistent with the assumptions, allocations, and requirements in the approved TMDL, these will be developed on a site by site basis
- Storm water discharges that the NDDOH determines will cause or has the reasonable potential to cause or contribute to violations of water quality standards
- Discharges from hydrostatic testing, well points, water line disinfection and treatment of gasoline or diesel contaminated groundwater
- Discharges of wash water using detergents, wastewater, or sanitary waste

NDR10-0000 does not relieve the reporting requirements of 40 CFR 110, 40 CFR 117 or 40 CFR 302. Any release of a hazardous substance must be reported to the agencies identified in Part IV.A.7 of NDR10-0000. Should a reportable release occur, this SWPPP shall be revised to prevent the recurrence of such a release.

### Notice of Intent (NOI) – Obtaining Coverage and Authorization

HBIC II will provide the following information to the NDDOH to obtain authorization under the permit number NDR10-0000

- Owner name, mailing address and phone number
- Project contact name and phone number
- List of counties where construction will occur
- Brief description of construction activity
- The signature of the applicant(s), signed in accordance with Part IV-E of NDR10-0000
- The name of receiving water(s), or the name of the municipal storm sewer system and receiving water(s)

HBIC II will maintain a database of all construction activities.

### **Terminating Permit Coverage**

Compliance with the conditions in this plan is required until the permittee has submitted a Notice of Termination (NOT) and it is accepted by the NDDOH.

The NOT must identify the project, reason why the permit is no longer needed and be signed in accordance with Part IV.A.6 of NDR10-0000.

A NOT will not be submitted until storm water discharges associated with construction activities are eliminated and final stabilization is achieved in accordance with Part II.E, or when another operator/permittee has assumed control in accordance with Part 1.F of NDR10-0000.

## **SITE DESCRIPTION**

This plan covers various well locations and associated access roads and pipelines throughout HBIC II's several fields. These are located in Burke, Dunn, McKenzie, Mountrail, Stark, Ward and Williams Counties. A database of all sites shall be kept on file and will include the following:

- Legal description of site location
- Estimated total site area and area of disturbance
- Proposed timetable of soil disturbance activities
- Description of the soil within disturbed area
- The name of surface waters at or near the disturbed area that may receive discharges from the project site
- Site maps indicating drainage patterns, construction site boundaries and areas of soil disturbance, avoidance areas, run-on and runoff flow direction, discharge points, pre and final grades, Best Management Practices (BMPs) to be used, stormwater conveyances, location of soil stockpiles, steep slopes, locations where stormwater is discharged to surface waters, and any other nearby items of concern
- The contractor overseeing implementation of the SWPPP and the installation, inspection, and maintenance of the erosion and sediment control BMPs before and during construction
- Indication of sites that have reached final stabilization
- Projects that have a discharge to a water body listed as impaired under section 303(d) of the Federal Clean Water Act due to sediment, suspended solids, or turbidity will identify the water body and impairment

## **STANDARD CONSTRUCTION PRACTICES**

HBIC II construction sites consist of a system of well locations, access roads and pipeline facilities. Several sites may be under construction simultaneously. Soil disturbing activities will consist primarily of site excavation, grading, and leveling.

An estimated sequence of soil disturbing activities follows:

### **Site Grading Including Excavation of Dry Cuttings Pit**

Begin site grading and topsoil stripping. A V-Ditch may be cut into the pad, which runs storm water off toward the natural drainage area. The site will be graded and leveled in accordance with design specifications. This may include an impoundment area used for spill prevention.

Stormwater that is contained here will either be allowed to naturally evaporate or discharged via gate valve, if applicable. Stormwater will only be discharged if it has been properly inspected.

Establish topsoil stockpile. Spoil material from excavation of dry cuttings pit will be stockpiled for backfilling. Stormwater controls will be installed as soon as a need is identified, generally when the material is located on a slope leaving the site or nearby a waterway or ditch. Perimeter controls should be placed continuously when installed on a slope leaving the site. During the winter, effort will be made to install stormwater controls although it may need to be delayed until the following spring when the ground has thawed.

#### **Site Surfacing**

Pad and access road will be surfaced with scoria or gravel as soon as grading is complete.

#### **Mobilize Project Specific Equipment**

General construction activities including foundation, building and equipment installation and rig mobilization will occur. Pipelines will be installed, inspected and repaired (as needed).

#### **Completion of Construction Activities**

Excavations will be backfilled, and the site reclaimed for production purposes. Additional stormwater measures will be implemented, if necessary.

#### **Demobilize Project Specific Equipment**

Equipment will be removed from construction site.

#### **Final Stabilization**

If needed, disturbed areas will be seeded. Seeding will take place as soon as practical after construction activities are complete. Seed and fertilizer will be applied based on the seed distributor's recommendations. Stabilized areas will be monitored until final stabilization is met. Remove all temporary control BMP's and stabilize any areas disturbed with erosion controls.

#### **Access Road Construction**

Access road construction is necessary to provide access to each well and will usually be permanent to allow movement of equipment in and out of the locations initially and during subsequent maintenance and operations. These roads will also provide access for periodic monitoring.

The following guidelines will be used to the extent practical during road siting:

- Existing roads will be used where possible to minimize soil disturbance and protect natural features and soil.
- Existing contours will be followed to minimize road grades and lessen the potential of water erosion.
- Road grades will be kept at a minimum when possible. In areas where it is necessary to have severe grades, silt fence, fiber rolls, water bars, or other adequate sediment controls will be used in ditches to reduce runoff velocities and prevent erosion and sedimentation.

The following guidelines will be used to the extent practical during road construction:

- When feasible, road locations will avoid highly erosive soils and wetlands. However if it

is necessary to construct roads in these areas, erosion control methods and wetland road construction techniques will be used to minimize the disturbance to these areas.

- No known hazardous or toxic materials will be used in roadbed construction.
- Vegetated buffer strips will be maintained between streams, wetlands, and/or floodplains and roads to slow runoff, provide area for runoff to permeate soil, and filter sediment. Other permanent methods (geotextile, riprap, matting, etc.) may be used instead of or in addition to vegetated buffer strips, provided the watercourse is not altered or diverted.
- Measures will be taken to prevent construction materials (dirt, boulders, rock, grass, trees, etc.) from being deposited into water bodies. However, if these materials inadvertently enter the water body, they will be removed immediately.
- Road will be surfaced with scoria or similar material as soon as leveling and grading is complete to prevent erosion.
- When applicable, cattle guards may be used as rumble strips.
- Contractors will be familiar with construction techniques providing erosion control.

Due to the topography of the operational area, roadways will need to cross streams. The following guidelines, where practical, will be used in developing road-stream crossings:

- Stream crossings will be minimized as practical. Existing culverts, bridges, fords and/or other crossings will be employed whenever possible.
- Crossings, where practical, will be made at right angles to the main stream channel.
- No known hazardous or toxic materials will be used in road-stream crossings.
- The crossing will be designed to withstand a 2 year, 24 hour storm event.

#### **Well Location Construction**

Well location construction is necessary to provide an area adequate to allow movement of the drilling rig and associated equipment on to the site to begin production. This location is all weather accessible to provide operation, maintenance and observation of the well. The drilling pad is kept as small as possible to minimize soil disturbance and protect natural features and soil.

The following guidelines will be implemented where practical in well location construction:

- Pad size will be as small as practical to minimize soil disturbance.
- All slope grades will be kept to a minimum and proper construction techniques will be used to control erosion. In order to maintain sheet flow and minimize rills and/or gullies, there will be no unbroken slope length of greater than 75 feet for slopes with a grade of 3:1 or steeper.
- Pads and/or pits will be constructed a sufficient distance away from stream beds, wetlands or flood lands to allow for a vegetative buffer to prevent soil from entering the water bodies. When pads and/or pits are constructed near water bodies, measures will be taken to protect that surface water quality. Where sufficient area is not available, other erosion control methods will be used in addition to or instead of vegetative buffers provided the water is not altered or diverted.
- Measures will be taken to prevent construction materials (dirt, boulders, rock, grass, trees, etc.) from being deposited into water bodies. However, if these materials inadvertently enter the water body, they will be removed immediately.
- Temporary soil stockpiles will have effective sediment controls, if necessary. This is generally required when the stockpile is located on a slope leaving the site or nearby a

waterway or ditch.

- Contractors will be familiar with construction techniques providing erosion control. Training will occur on at least an annual basis. New employees will be trained as necessary to ensure compliance with this plan and permit number NDR10-0000.
- Reserve pits will not be located in, or hazardously near, bodies of water, and will not block natural drainages. No reserve pit will be wholly or partially constructed in fill dirt unless approved by the director of the North Dakota Industrial Commission.
- Dry cuttings pits will be lined with non-permeable material. Operators will take care not to puncture or tear pit liner. Should this happen, pit liner will be repaired or replaced immediately and will show no evidence leaking.
- Dry cuttings pits will be closed in accordance with North Dakota Laws.
- Operators will prevent, as practical, the placing of trash or other materials into a pit which would increase difficulty of cleanup of the pit. Such material will be properly stored and disposed of according to applicable state or federal regulations. No garbage will be burned or buried on site. All garbage and trash will be disposed of at an approved landfill site.

### **Pipeline Construction**

Pipeline construction is necessary for the gathering of production materials from remote locations to processing and disposal facilities. Surface disturbance is minimal and site reclamation begins quickly after the start of construction.

The following guidelines will be used at the extent practical when siting pipelines:

- Gathering lines will follow road rights-of-way when possible.
- Stream crossings will be minimized if roadways cannot be followed. If it is necessary to cross a stream, measures will be taken to minimize stream disturbance and proper erosion controls will be used to prevent sediment runoff into stream.
- Pipeline grades will be kept at a minimum when possible.
- Right-of-ways will be as small as practical to minimize soil disturbance.

The following guidelines will be used to the extent practical during pipeline construction:

- In areas where it is necessary to have severe grades, silt fence, fiber rolls or other adequate sediment controls will be used to reduce runoff velocities and prevent erosion and sedimentation.
- When feasible, pipeline locations will avoid highly erosive soils and wetlands. However if it is necessary to construct pipelines in these areas, erosion control methods and wetland pipeline construction techniques will be used to minimize the disturbance to these areas.
- Vegetated buffer strips will be maintained between streams, wetlands, and/or floodplains and pipelines to slow runoff, provide area for runoff to permeate soil, and filter sediment. Other permanent methods (geotextile, riprap, matting, etc.) will be used instead of or in addition to vegetated buffer strips, provided the watercourse is not altered or diverted.
- Contractors will be familiar with construction techniques providing erosion control
- Pipeline surface disturbance will be minimized.

## OPERATIONAL CONTROLS

Day to day construction operations shall be performed in a manner that reduces the contribution of pollutants to stormwater runoff. A contractor knowledgeable and experienced in the application of erosion and sediment control BMPs will oversee the implementation of this plan and the installation, inspection, and maintenance of the BMPs before and during construction. Employees will be trained on their responsibility in implementing practices and controls such as spill response, good housekeeping, and sediment control practices. Training will occur on at least an annual basis. New employees will be trained as necessary to ensure compliance with this plan and permit number NDR10-0000.

### **Material Handling and Management Practices**

The following good housekeeping practices will be followed, to maintain a clean and orderly site and reduce the risk of spills or other runoff contamination:

- Adequate waste receptacles will be provided for the proper disposal of trash and debris
- Personnel will be instructed regarding the correct disposal of trash and construction debris
- All waste materials, including sanitary wastes, will be removed to an appropriate licensed disposal/recycling facility
- Materials on site will be kept in their original containers and labeled accordingly
- Partially empty containers will be used at another site, recycled, or returned to the manufacturer
- Manufacturers' recommendations for proper use and disposal will be followed
- Vehicular traffic will be minimized as much as possible to reduce dust and prevent soil erosion
- The site will be watered if necessary to reduce dust during dry periods
- Access roads will be surfaced as soon as grading is complete.
- If sediment is tracked onto paved surfaces, it will be cleaned up as soon as possible.

### **Spill Prevention and Control Practices**

Employees are trained in proper methods for cleanup of spills of various products used on site. Employees are aware of the location of related information, materials and equipment necessary for storage requirements, spill containment, and cleanup of potential spills.

All spills will be cleaned up immediately upon discovery and the appropriate agencies notified, if needed.

All vehicles and equipment will be checked for leaking oil or other fluids. Leaks will be repaired immediately. Vehicles or equipment unfit for use will be removed from the project site. Vehicles and equipment will be fueled and lubricated a sufficient distance from any drainage pattern.

### **Well Pad Cut Slopes**

Where applicable, diversion ditches will be placed at the top of all well pad cut slopes to divert stormwater run-off away from the well pad surface. Diversion ditch exit points will be properly stabilized to prevent erosion. Erosion and sediment controls will generally not be used on slopes down to the well pad site since the sediment does not risk leaving the site. These areas will be stabilized and seeded as soon as possible after grading is complete. For winter construction this may be in the following spring once the ground has thawed.

## EROSION AND SEDIMENT CONTROLS

All control measures must be properly selected, installed, and maintained in accordance with the manufacturer's specifications and good engineering practices. BMPs must be inspected and replaced or modified when necessary. Natural drainage will be the method of water release. Sites will be graded such that water runs toward the natural drainage direction. BMPs will be utilized at the point of discharge to prevent erosion.

Stormwater discharges will not be made unless water is flooding the site. If a stormwater discharge is necessary, prior to releasing any collected storm water, assure there are no hydrocarbon odors or sheen observed on or in the water. **If there is any doubt the water is only clean storm water, contact facility management or EHS personnel prior to releasing the storm water.** A contact list can be found as Appendix 1. Discharges will be performed and documented in accordance with Appendix 2.

All discharges should:

- Occur before retention area is full (within two feet of the top) & surrounding area is dry
- Be made offsite to stabilized (vegetation) ground
- Occur over a 48 hour period if large volumes
- Avoid flood nearby
- Be made to a rock check or other natural drainage
- Utilize additional BMPs when necessary
- Take into account adjacent land conditions whenever feasible

All stormwater discharges must be documented. A stormwater discharge report form is provided in Appendix 2. The following information should be retained in the facility file:

- Date
- Time(s) of release
- Location name/description
- Verification of no sheen, odor, or any other indication of contaminants
- Estimated volume of release
- Personnel releasing water
- Condition of surface where water was released (no erosion)
- Confirmation of any gates or valves that were closed/locked

Stormwater controls are expected to withstand and function properly during precipitation events up to the 2 year, 24 hour storm. Visible erosion and/or off-site sediment deposition from such storm events should be minimal. If sediment escapes from the site, off-site accumulations must be removed at a frequency sufficient to minimize off-site impacts.

The following is a summary of BMPs to be utilized:

- Silt Fence
- Straw Waddles
- Rock Check Dams
- Erosion Control Blankets

- Straw or Mulch
- Sedimentation Traps
- Waterbars
- Swales and Diversion Ditches
- Riprap
- Other Sediment and Erosion Controls as Deemed Necessary

See Appendix 3 for BMP Details outlining proper use and installation.

A hydrovac may be used during construction. In order to prevent an illicit discharge associated with hydrovac spoils, all hydrovac discharges will be performed in accordance with the Hydrovac Spoil Discharge Specification, Appendix 4.

### **MAINTENANCE AND INSPECTIONS**

Inspections will be conducted to monitor the condition of storm water discharge outlets and effectiveness of BMPs. They will be performed at least once every 14 calendar days and within 24 hours after any storm event of greater than a 0.25 inch per 24-hour period during active construction. Inspections are only required during normal working hours. Storm events will be determined by the inspector either by using a rain gauge located on-site or the nearest National Weather Service precipitation gauge station. Areas that are stabilized, but do not have 70% vegetative cover may be inspected once per month. These are locations where all soil disturbing activity is complete and no further erosion can be reasonably expected to occur. If weather conditions prevent inspections, they will take place on the next possible day. Inspections will be suspended when the ground is frozen and no sediment displacement is expected.

If dewatering occurs on site (groundwater or surface drainage pumping or trench /ditch cuts for drainage) the activity must be inspected and documented daily. Discharges must not lead to the deposition of sediment within stormwater conveyance systems or surface waters. Inspections and discharges will be performed and documented in accordance with Appendix 2.

All erosion and sediment control measures identified in this plan will be maintained in effective operating condition. If site inspections identify BMPs not operating effectively, maintenance will be arranged and accomplished within 24 hours of discovery or as soon as practical. BMP maintenance requirements are outlined in Appendix 3.

Following are some guidelines when conducting inspections:

- Disturbed areas and areas used for storage of materials exposed to precipitation will be inspected for evidence of, or the potential for pollutants entering the drainage system.
- All erosion and sediment control measures in the plan will be inspected to ensure they are implemented, maintained and operating effectively to minimize erosion and prevent storm water contamination from construction materials.
- Vehicles and equipment on site will be checked for oil or other fluid leakage.
- Any drainage near the site will be observed to ensure no contamination is occurring.
- Chemical storage containers, if any, will be inspected to ensure they are not leaking.
- Reseeded soil will be monitored for washouts and bare spots.
- If site is near a paved road, entrances and exits will be inspected for evidence of offsite sediment tracking.

### **Inspection Documentation**

Until the site is stabilized, personnel familiar with permit conditions and the proper installation and operation of control measures shall perform inspections to monitor all disturbed areas, areas used for storage of materials exposed to precipitation, storm water control measures and locations where vehicles enter or exit the site.

Inspections will be documented and sent to HBIC II (See Appendix 1 for contact information, Appendix 5 for inspection document). Records of maintenance and inspection activity will include:

- Date, time and name of person(s) conducting inspections.
- Assessment of effectiveness of BMP's and whether repair or maintenance is warranted (Deficiencies shall be corrected as soon as possible).
- Descriptions of corrective actions taken.
- Dates of rainfall events of  $\frac{1}{4}$  inch or greater in a 24 hour period.
- Documentation that the SWPPP has been amended in response to deficiencies found during inspections, if necessary.

## **PLAN REVIEW, REVISIONS, AND RECORDS**

The plan will be signed in accordance with Part IV.A.6 of NDR10-0000. Copies of the signed NOI, coverage letter from the NDDOH, this plan, site inspections records, and permit NDR10-0000 will be retained at the HBIC II office in Minot, North Dakota.

The plan will be amended whenever there is a change to design, construction, operation or maintenance which could have a significant effect on the potential for the discharge of pollutants to the waters of the state.

The plan will be amended if it is found to be ineffective in controlling pollutants present in storm water.

The plan will be made available, upon request, to the North Dakota Department of Health or United States Environmental Protection Agency.

Copies of the SWPPP and all documentation required by NDR10-0000 will be retained for at least three years from the date of final stabilization of the site.

## **FINAL STABILIZATION**

All sites must reach final stabilization. A Notice of Termination (NOT) will be submitted within 30 days after final stabilization is complete, or another owner has assumed control over all areas that are not stabilized.

Final stabilization will be achieved when:

- All soil disturbing activities are complete and all soils are stabilized with a uniform perennial vegetative cover with a density of 70 percent of preexisting levels over the entire surface area, or other equivalent means necessary to prevent soil failure in erosive conditions.
- For areas with an average annual rainfall of less than 20 inches only, all soil disturbing activities at the site have been completed and temporary erosion control measures are selected, designed, and installed along with an appropriate seed base to provide erosion control for at least three years and achieve 70 percent vegetative coverage within three years without active maintenance.
- For activities on land used for agricultural purposes, final stabilization will be accomplished by returning the disturbed land to its pre-disturbance use.

## SWPPP CERTIFICATION

### Certification Instructions:

The SWPPP must be signed by a responsible corporate officer, a general partner, a principal executive officer or a ranking elected official of the owner(s).

The SWPPP may be signed by a duly authorized representative of the owner described above only if:

- The authorization is made in writing by a person described above and submitted to the Department; and
- The authorization specifies either an individual or a position having responsibility for the overall operation of the regulated facility, such as the position of plant manager, superintendent, position of equivalent responsibility, or an individual or position having overall responsibility for environmental matters.

### Certification:

I certify under penalty of law that this document and all attachments were prepared under my direction or supervision in accordance with a system designed to assure that qualified personnel properly gather and evaluate the information submitted. Based on my inquiry of the person or persons who manage the system, or those persons directly responsible for gathering the information, the information submitted is, to the best of my knowledge and belief, true, accurate, and complete. I am aware that there are significant penalties for submitting false information, including the possibility of fine and imprisonment for knowing violations.

HESS BAKKEN INVESTMENTS II, LLC

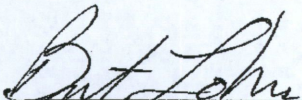
  
\_\_\_\_\_  
HBIC II Director

1/13/2016  
\_\_\_\_\_  
Date

## APPENDIX 1 CONTACT LISTS

### GENERAL PROJECT CONTACTS

<b>Project Contacts:</b>	<b>Primary Telephone:</b>	<b>Email:</b>
Stetson Sannes- <i>Regulatory Analyst, Bakken</i>	701-420-7002	<a href="mailto:ssannes@hess.com">ssannes@hess.com</a>
Vicky Sund- <i>Regulatory Manager, Bakken</i>	701-420-7020	<a href="mailto:vsund@hess.com">vsund@hess.com</a>

### COMPANY MANAGEMENT CONTACTS

<b>Management Contacts</b>	<b>Primary Telephone:</b>	<b>Email:</b>
Brian Epperson- <i>Senior Manager, EHS &amp; Regulatory</i>	713-496-7296	<a href="mailto:bepperson@hess.com">bepperson@hess.com</a>
Nate Hagerott- <i>Team Lead, Facilities</i>	701-420-7087	<a href="mailto:nhagerott@hess.com">nhagerott@hess.com</a>
Eric Rolli- <i>Team Lead, Project Engineering</i>	701-420-6925	<a href="mailto:erolli@hess.com">erolli@hess.com</a>

### COMPANY EHS CONTACTS

<b>EHS Contacts:</b>	<b>Primary Telephone:</b>	<b>Email:</b>
Brandon Herda- <i>Manager, EHS Well Factory</i>	701-420-7078	<a href="mailto:bherda@hess.com">bherda@hess.com</a>
Clint Young- <i>Manager, EHS Infrastructure</i>	701-420-7170	<a href="mailto:cyoung@hess.com">cyoung@hess.com</a>
Rob Bates- <i>Supervisor, EHS</i>	701-664-6509	<a href="mailto:robbates@hess.com">robbates@hess.com</a>

**APPENDIX 2**

**STORMWATER DISCHARGE PROCEDURES**



**I. PURPOSE**

To provide site personal with guidance for the discharge of surface water

**II. SCOPE**

Applicable to all site personal located in North Dakota

**III. DISCHARGE SPECIFICATIONS**

Storm water discharge is prohibited by the following:

- A. Color - A qualified employee should inspect storm water for evidence of discoloration. Testing should be conducted if pollutants are present.
- B. Odor – A qualified employee should inspect storm water for evidence of a hydrocarbon smell (i.e. oil or gas). Testing should be conducted if pollutants are present.
- C. Sheen – A qualified employee should visually inspect storm water for evidence of oil sheen. Testing should be conducted if pollutants are present.

**IV. DISCHARGE LIMITATIONS**

If storm water meets the discharge specifications listed in Section III, the storm water can be discharged if the following erosion requirements are also met:

- A. The flow rate must be controlled to limit surface erosion. The use of an electric transfer pump or a double diaphragm pump is suggested.
- B. Flow direction must be controlled to prevent soil erosion. If possible, select discharge points where the flow path isn't bare.

**V. Exceptions**

If there are any exceptions, seek an EHS professional for further assistance



## Water Discharge Specification

### VI. Process Flow Chart

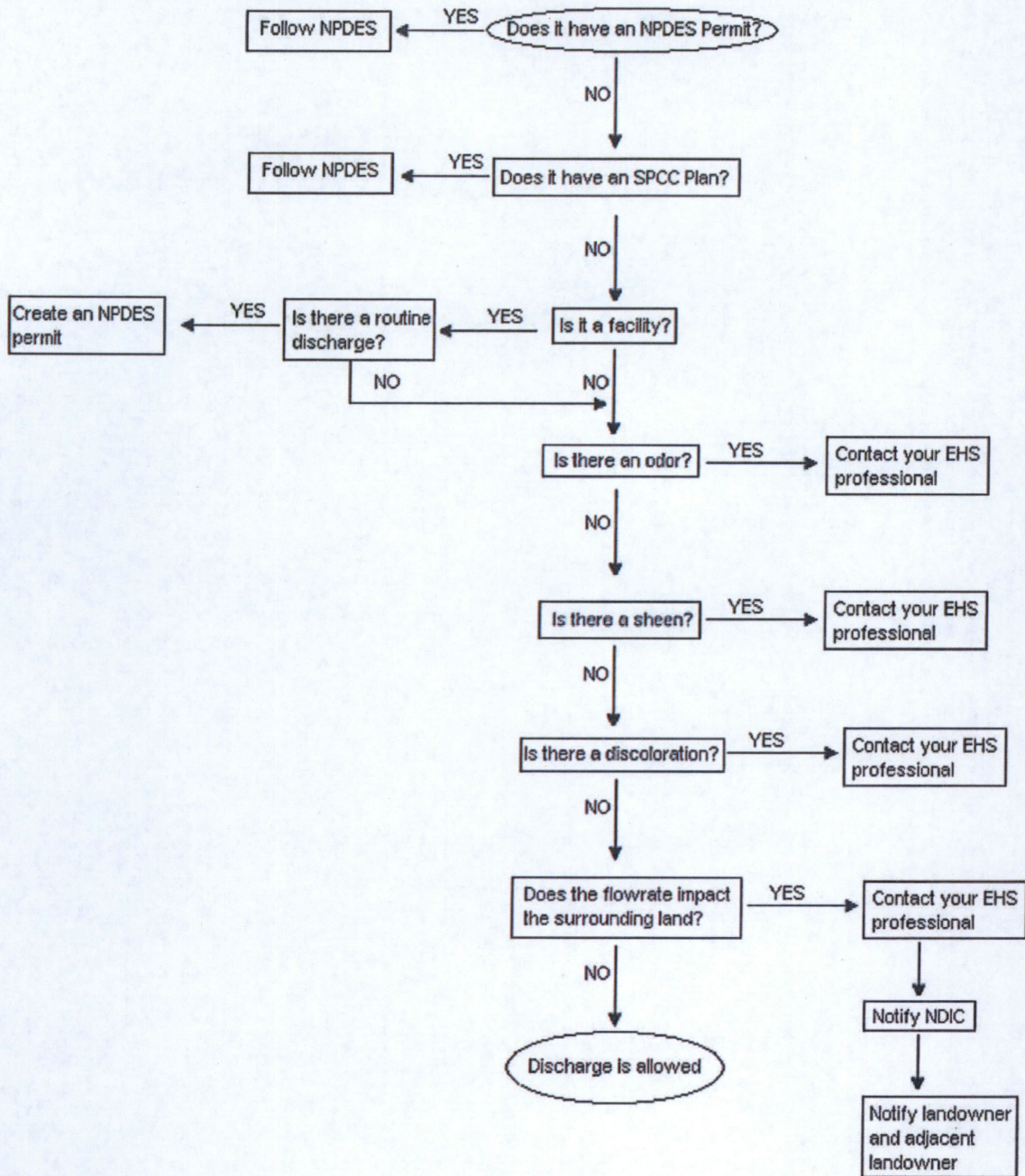

SPCC/SWPPP Stormwater Discharge Report Form



**Stormwater Discharge Report Form**  
**Hess Corporation**  
 3015 16<sup>th</sup> St. SW, Suite 20  
 Minot, ND 58701

Wellsite: \_\_\_\_\_  
 Operator: \_\_\_\_\_

1. Does this Site Fall Under the NDR10-0000 SWPPP Permit for a Non-Stabilized Site?
  - Yes - Attach Completed SWPPP Inspection Sheets
  - No
  
2. Is this discharge free from odor, sheen, and discoloration?
  - Yes
  - No – Do not discharge water, contact your EHS professional
  
3. Does the flowrate impact the surrounding land?
  - Yes – Contact your EHS professional,  
 (NDIC and landowner must be notified prior to discharge).
  - No
  
4. Has the landowner been contacted?
  - Yes
  - No – Recommend contacting the landowner prior to discharge
  
5. Discharge water and fill in form below.

DATE:	TIME START:	TIME STOP	WATER SAMPLING*	ESTIMATED VOLUME (GALLONS)	COMMENTS:
			<input type="checkbox"/> Yes <input type="checkbox"/> No		
			<input type="checkbox"/> Yes <input type="checkbox"/> No		
			<input type="checkbox"/> Yes <input type="checkbox"/> No		
			<input type="checkbox"/> Yes <input type="checkbox"/> No		
			<input type="checkbox"/> Yes <input type="checkbox"/> No		
			<input type="checkbox"/> Yes <input type="checkbox"/> No		

\*Water sampling is not required, but recommend.

Form to be used for site dewatering during production or site construction. Operators are responsible for site dewatering and form completion during well production. Prior to the start of production, designated construction personnel are responsible for form completion and dewatering. If this site falls under a DOH construction SWPPP permit, a SWPPP inspection must be completed every 24hrs while site dewatering is occurring. Contact the Hess Regulatory Department with any comments or concerns: 701.420.7077 or [ndregulatory@hess.com](mailto:ndregulatory@hess.com)

Please scan a digital copy of this completed form to [ndregulatory@hess.com](mailto:ndregulatory@hess.com). Email title should be structured Stormwater Discharge-Date-HessArea.

**APPENDIX 3**

**BMP DETAILS**

To be installed based on locations shown in the Site Specific Construction Documents or additional areas experiencing erosion as discovered during SWPPP inspections. Silt Fence will generally be installed downstream of well pad and access road grading areas where sediment could potentially leave the site. Silt Fence will also be utilized along pipeline construction routes in areas where vegetative buffers are not adequate or to protect stream crossings. Other areas to be protected by silt fence are diversion ditch exit points, culverts, and road ditches. In these areas the fence shall be installed in a J-Hook formation as shown below. Temporary soil stockpiles will be protected by silt fence only when necessary when located on a slope leaving the site or nearby waterways or ditches. Vegetative buffers should be used alongside silt fence whenever possible. Silt fence is to be removed once the site is determined to have reached final stabilization.

Sediment must be removed from behind silt fence once it reaches 1/3 the height of the fence. Silt fence must be replaced if fabric becomes worn from excessive wind or UV exposure. Repairs must be made within 24 hours of discovering that the silt fence needs maintenance or

as soon as field conditions allow access.

**NOTES:**

- PLACE BOTTOM EDGE OF FENCE INTO 6" (153 mm) DEEP TRENCH AND BACKFILLED IMMEDIATELY.
- POSTS SHALL BE:
  - 4' (1.22 m) ON CENTER
  - 2" (50.8 mm) X 2" (50.8 mm) HARDWOOD, PINE OR STEEL FENCE POSTS. MINIMUM LENGTH 4.5'
  - DRIVEN 2' (0.61 m) INTO THE GROUND.

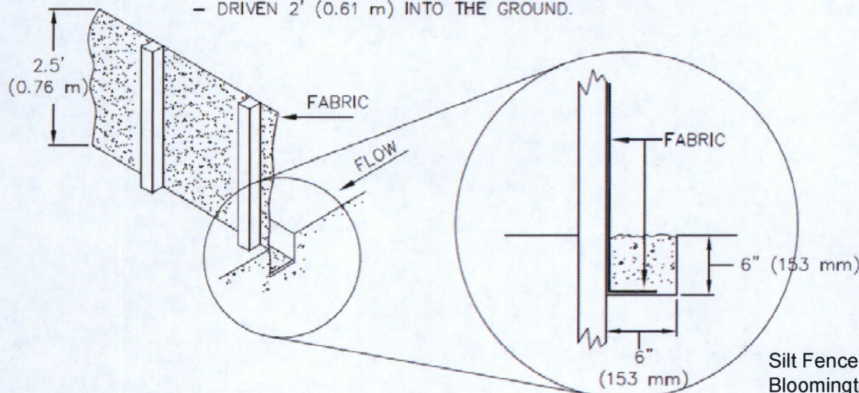

Silt Fence graphic from City of Bloomington, MN Construction Details

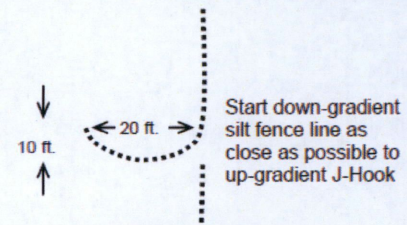
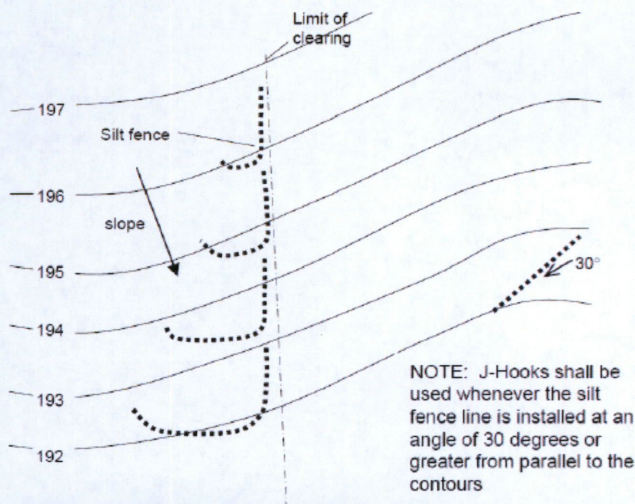

**Typical J-Hook Dimensions**

Minimum width of J-Hook recommended at 20 ft with a depth of 10 ft. Where space is limited (e.g., along narrow rights of way), narrower hooks can be used with a higher spacing frequency.

J-Hook graphics from CNMI/Guam Stormwater Management Manual, May 2010



**Appendix 3  
Detail 1 -Silt Fence**

This diagram provides general recommendations, refer to the manufacturer for specific installation instructions.

To be installed based on locations shown in the Site Specific Construction Documents or additional areas experiencing erosion as discovered during SWPPP inspections. Standard areas to be protected by straw wattles are diversion ditch exit points, culverts, and road ditches. Road ditches steeper than 5% will be protected with straw waddles 20' to 100' o.c. Ditches steeper than 8% shall be protected with straw waddles 10' to 50' o.c. with the wattles being placed over erosion control blanket if necessary. Diversion ditch exits shall be installed in a J-Hook formation as shown in Detail 1-Silt Fence. Temporary soil stockpiles will be protected by straw wattles only when necessary when located on a slope leaving the site or nearby waterways or ditches. If more than one straw wattle is used, the wattles should overlap laterally by at least one foot. Wattles stakes should be placed on the downstream half of the wattle as shown below, not directly on-center. Vegetative buffers should be used alongside straw wattles whenever possible. Straw wattles may either be removed once the site is determined to have reached final stabilization or may stay on site and naturally bio-degrade.

Sediment must be removed from behind straw wattles once it reaches 1/3 the height of the fence. Repairs must be made within 24 hours of discovering that the wattle needs maintenance or as soon as field conditions allow access. Extra attention should be paid to the possibility of erosion undercutting the wattles.

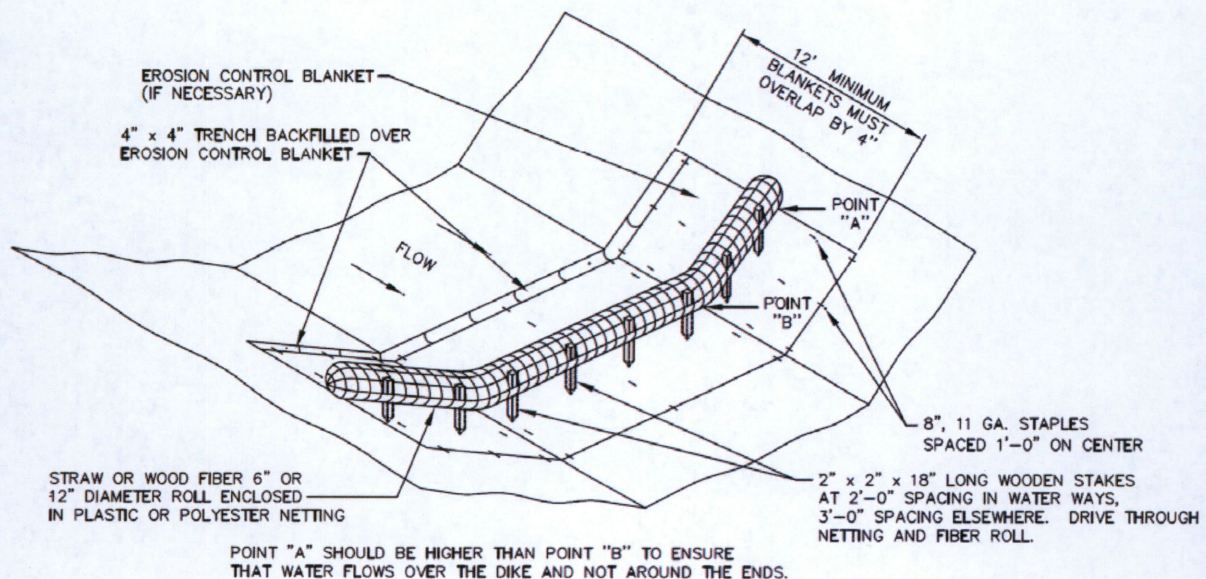

Straw wattle graphic from City of Bloomington, MN Construction Details



### Appendix 3 Detail 2 - Straw Wattles

This diagram provides general recommendations, refer to the manufacturer for specific installation instructions.

Typically slopes 3H to 1V or less shall be stabilized with conventional seeding equipment. Straw or mulch should be spread over fresh seed to avoid seed and topsoil run-off. Fertilizer should be applied per the seed distributors recommendations.

Slopes steeper than 3H to 1V may require stabilization with hydro-seeding, water bars, or erosion control blankets. Hydro-seed and erosion control blankets should be applied per the manufacturers recommendations. Water bars should be installed per the Site Specific Construction Documents. Below is a typical installation detail for Erosion Control Blanket.

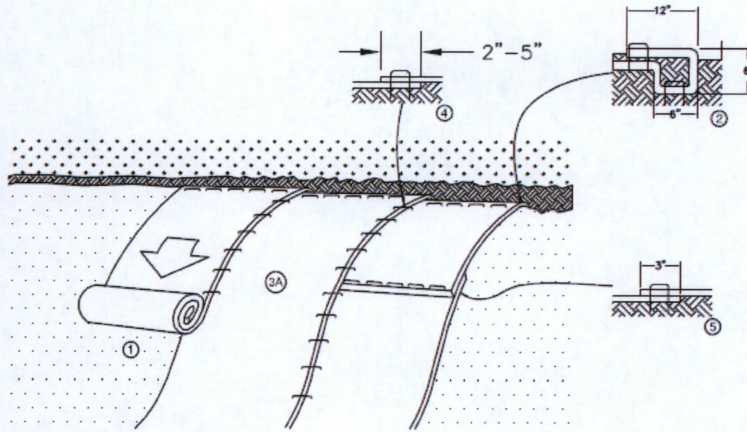

1. PREPARE SOIL BEFORE INSTALLING BLANKETS, INCLUDING ANY NECESSARY APPLICATION OF LIME, FERTILIZER, AND SEED. NOTE: WHEN USING CELL-O-SEED DO NOT SEED PREPARED AREA. CELL-O-SEED MUST BE INSTALLED WITH PAPER SIDE DOWN.
2. BEGIN AT THE TOP OF THE SLOPE BY ANCHORING THE BLANKET IN A 6" (15cm) DEEP X 6" (15cm) WIDE TRENCH WITH APPROXIMATELY 12" (30cm) OF BLANKET EXTENDED BEYOND THE UP-SLOPE PORTION OF THE TRENCH. ANCHOR THE BLANKET WITH A ROW OF STAPLES/STAKES APPROXIMATELY 12" (30cm) APART IN THE BOTTOM OF THE TRENCH. BACKFILL AND COMPACT THE TRENCH AFTER STAPLING. APPLY SEED TO COMPACTED SOIL AND FOLD REMAINING 12" (30cm) PORTION OF BLANKET BACK OVER SEED AND COMPACTED SOIL. SECURE BLANKET OVER COMPACTED SOIL WITH A ROW OF STAPLES/STAKES SPACED APPROXIMATELY 12" (30cm) APART ACROSS THE WIDTH OF THE BLANKET.
3. ROLL THE BLANKETS (A.) DOWN OR (B.) HORIZONTALLY ACROSS THE SLOPE. BLANKETS WILL UNROLL WITH APPROPRIATE SIDE AGAINST THE SOIL SURFACE. ALL BLANKETS MUST BE SECURELY FASTENED TO SOIL SURFACE BY PLACING STAPLES/STAKES IN APPROPRIATE LOCATIONS AS SHOWN IN THE STAPLE PATTERN GUIDE. WHEN USING OPTIONAL DOT SYSTEM, STAPLES/STAKES SHOULD BE PLACED THROUGH EACH OF THE COLORED DOTS CORRESPONDING TO THE APPROPRIATE STAPLE PATTERN.
4. THE EDGES OF PARALLEL BLANKETS MUST BE STAPLED WITH APPROXIMATELY 2"-5" (5cm-12.5cm) OVERLAP DEPENDING ON BLANKET TYPE. TO ENSURE PROPER SEAM ALIGNMENT, PLACE THE EDGE OF THE OVERLAPPING BLANKET (BLANKET BEING INSTALLED ON TOP) EVEN WITH THE COLORED SEAM STITCH ON THE PREVIOUSLY INSTALLED BLANKET.
5. CONSECUTIVE BLANKETS SPLICED DOWN THE SLOPE MUST BE PLACED END OVER END (SHINGLE STYLE) WITH AN APPROXIMATE 3" (7.5cm) OVERLAP. STAPLE THROUGH OVERLAPPED AREA, APPROXIMATELY 12" (30cm) APART ACROSS ENTIRE BLANKET WIDTH.
6. FOLLOW MANUFACTURER'S RECOMMENDED STAPLE PATTERN, FOR THE SLOPE FOR THE SPECIFIED BLANKET.

**NOTE:**

IN LOOSE SOIL CONDITIONS, THE USE OF STAPLE OR STAKE LENGTHS GREATER THAN 6" (15cm) MAY BE NECESSARY TO PROPERLY SECURE THE BLANKETS.

EROSION CONTROL BLANKET

Erosion Control graphic from City of  
Bloomington, MN Construction Details



**Appendix 3**  
**Detail 3 –Soil Stabilization**

This diagram provides general recommendations, refer to the manufacturer for specific installation instructions.

To be installed in diversion ditch exit and road ditch areas experiencing erosion as discovered during SWPPP inspections or areas expected to have concentrated rather than sheet flow. Rock check dams will be used in areas where J-Hook silt fence or straw wattles are not adequate.

Sediment must be removed from behind rock check dams once it reaches 1/2 the height of the dam. Repairs must be made within 24 hours of discovering that the dam needs maintenance or as soon as field conditions allow access.

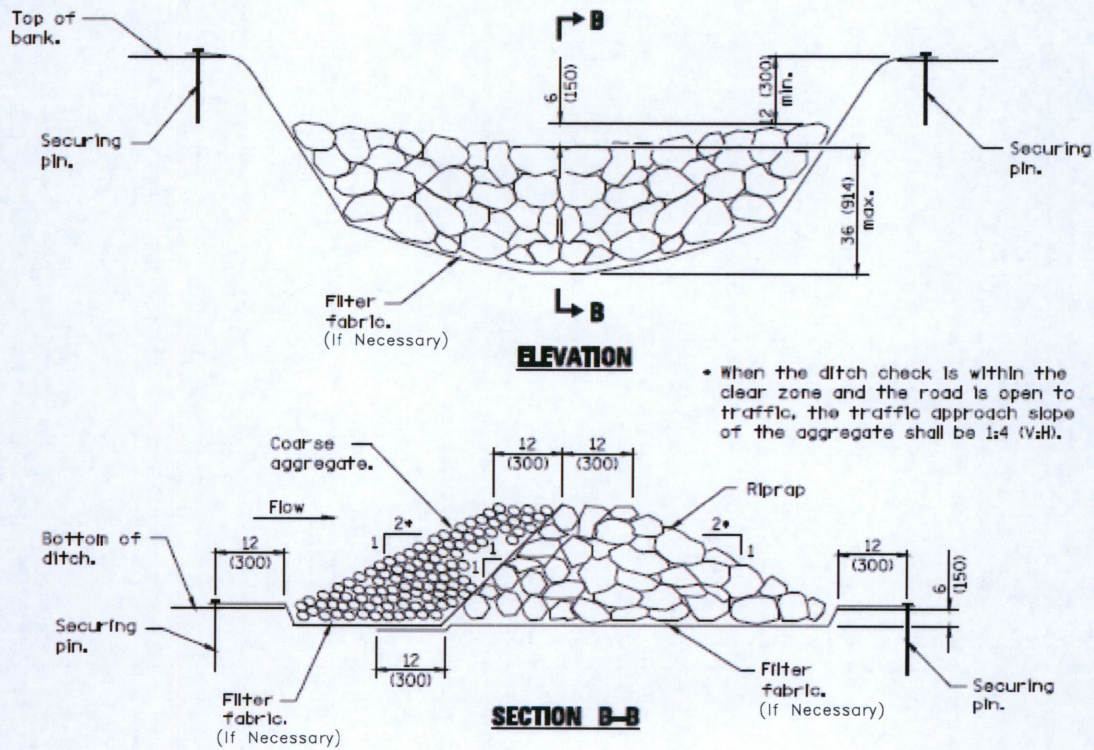

Erosion Control graphic from Illinois Department of Transportation Temporary Erosion Control Systems, Jan. 1, 2010



Appendix 3  
 Detail 4 –Rock Check Dam  
 This diagram provides general recommendations, actual installation may vary due to field conditions.

To be installed in diversion ditch exit and road ditch areas experiencing erosion as discovered during SWPPP inspections or areas expected to have concentrated rather than sheet flow. Sediment traps will be used in areas where J-Hook silt fence, straw wattles or rock check dams are not adequate.

Sediment must be removed from sediment traps once it reaches 1/2 the capacity of the trap. Drainage and removal must be completed within 72 hours of discovery or as soon as field conditions allow access.

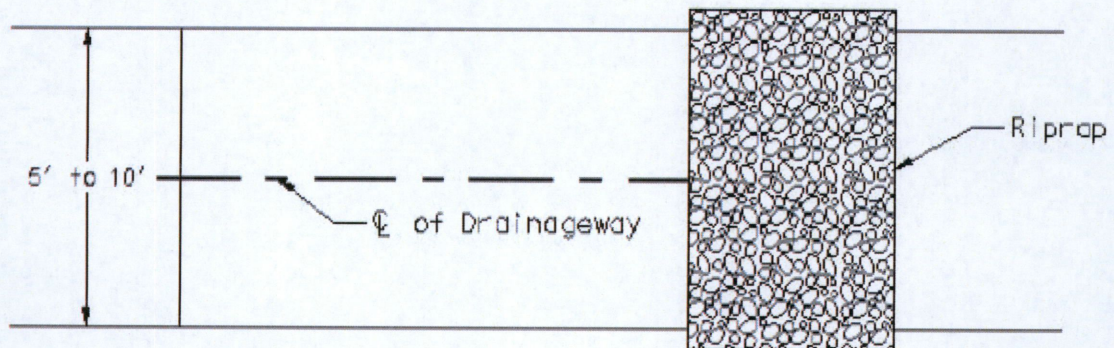

### Plan View of Sediment Trap

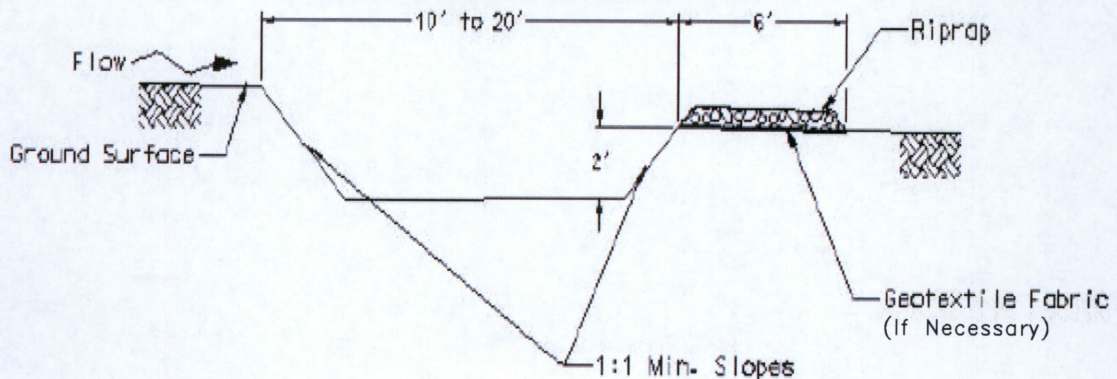

Erosion Control graphic from North Dakota  
Department of Transportation Erosion and  
Sediment Control Handbook, June 2004



### Appendix 3

#### Detail 5 –Sediment Trap

This diagram provides general recommendations,  
actual installation may vary due to field conditions.

Impacts to streams and wetland are minimized as much as possible. Occasionally stream crossings or wetland impacts are required. When impacts are impossible to avoid, floating silt curtains will be utilized in order to prevent sediment from traveling downstream.

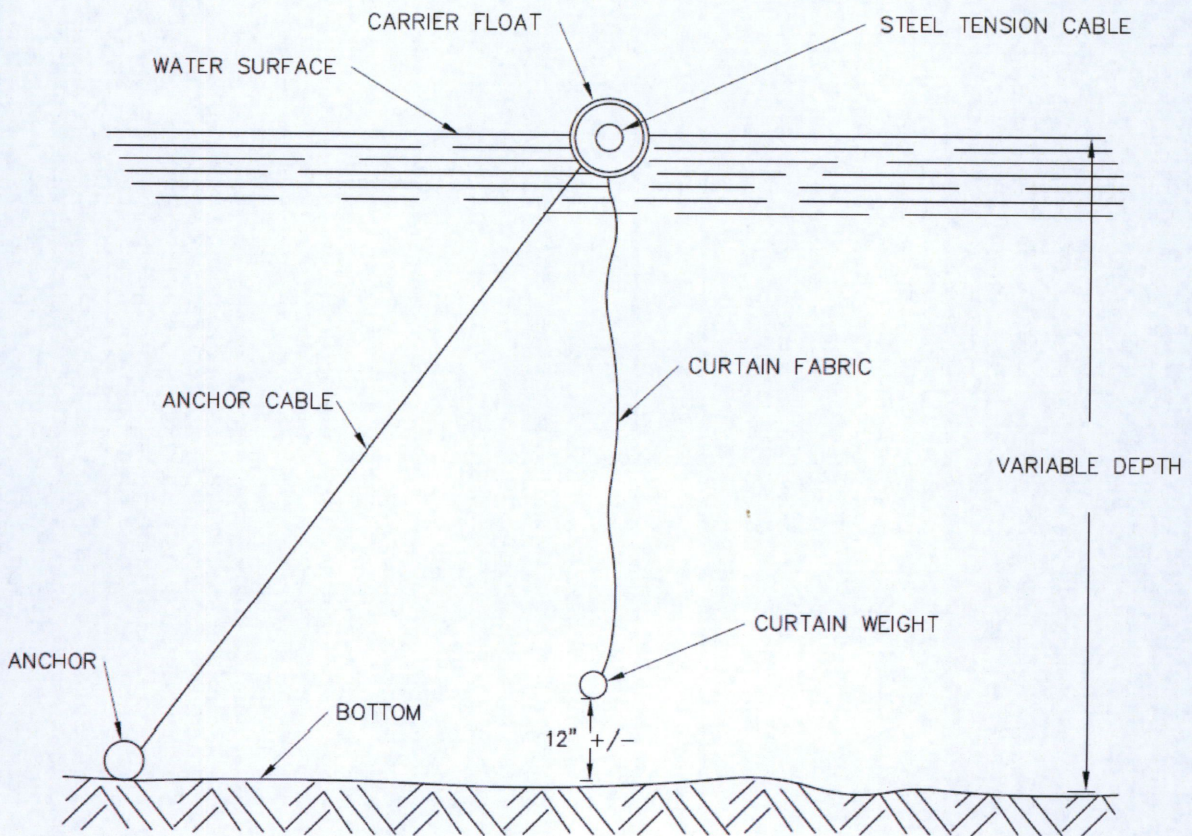

Erosion Control graphic from City of  
Bloomington, MN Construction Details



### Appendix 3

#### Detail 6 –Floating Silt Curtain

This diagram provides general recommendations, refer to the manufacturer for specific installation instructions.

Waterbars may be used in place of silt fence, straw wattles, or rock check dams in areas where reclamation is expected to happen quickly (for example on a pipeline project). These are not recommended when reclamation is expected to be delayed or in highly erodible soils.

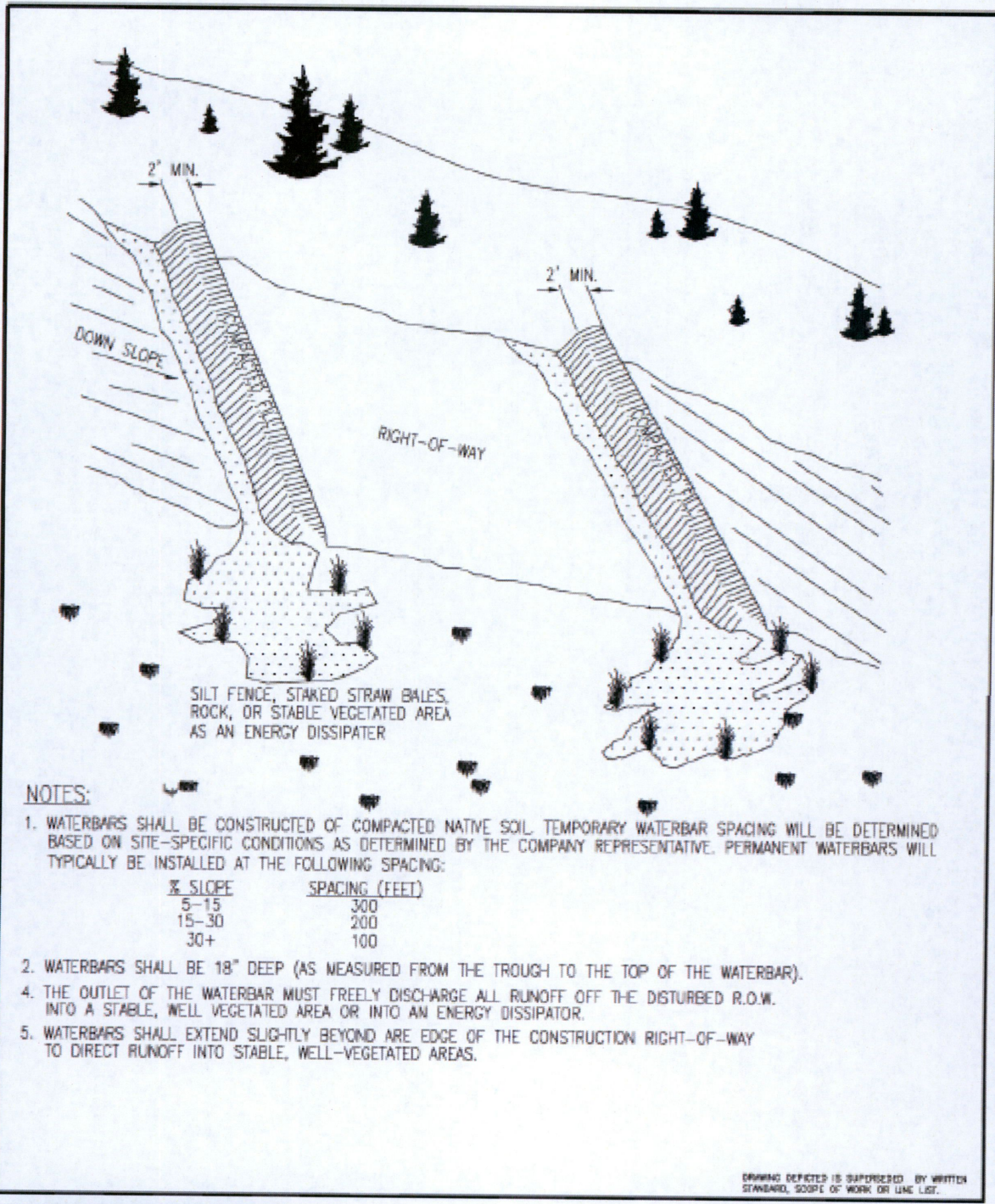

### Appendix 3 Detail 7 –Waterbar

This diagram provides general recommendations, actual installation may vary due to field conditions.

During construction, straw wattles will be utilized at culvert inlets and outlets (See Detail 2 for straw wattle installation details). Close attention should be paid to the possibility of erosion undercutting the wattles.

Riprap may be utilized at culvert outlets as a permanent BMP if scouring becomes an issue. Below is a recommendation for riprap installation.

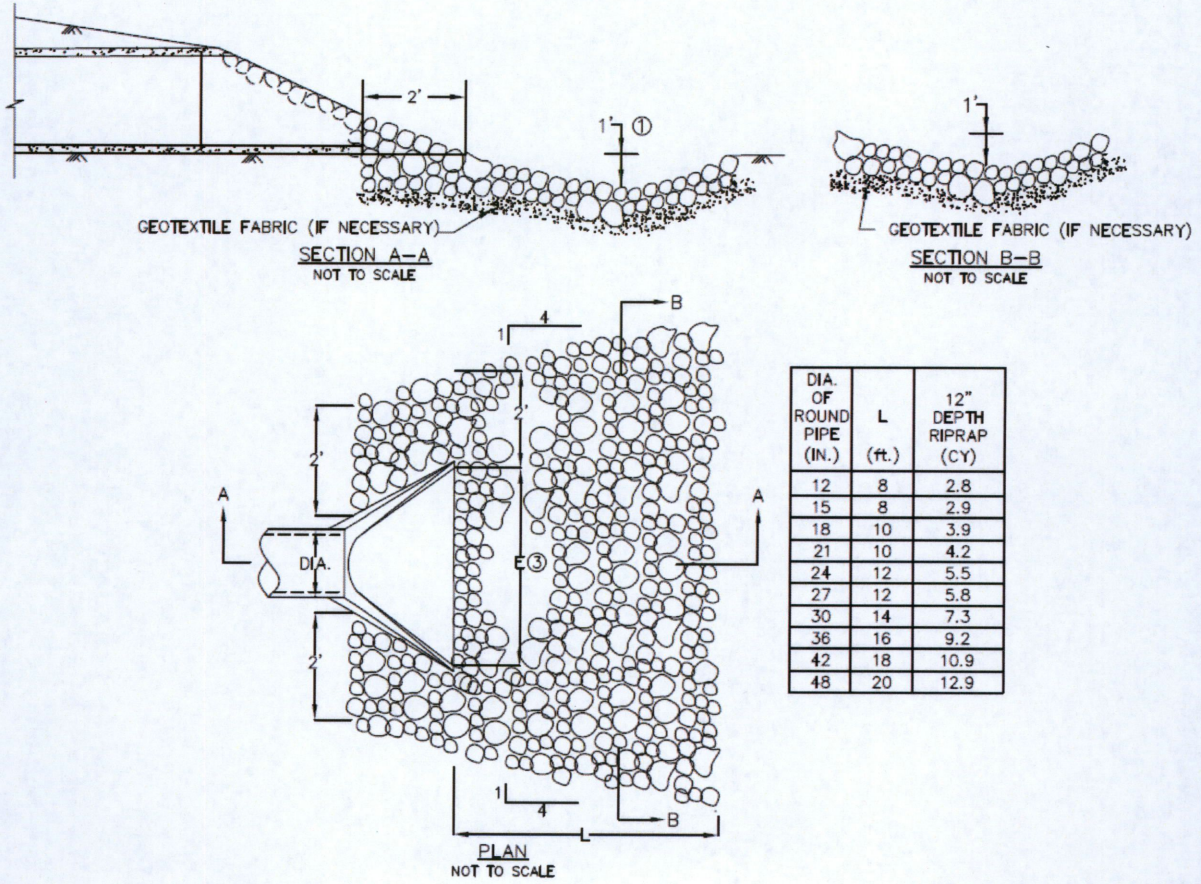

RIPRAP @ CULVERT OUTLETS

Graphic from City of  
Bloomington, MN Construction Details



Appendix 3  
Detail 8 –Culvert Energy  
Dissipation

Mulching involves the application of straw or other organic materials to form a temporary, protective soil cover. Mulch protects the soil surface from the forces of raindrop impact and overland flow. Organic mulches foster the growth of vegetation, reduce evaporation, insulates the soil, and suppresses weed growth.

**Materials**

Mulch material should consist of native hay or the straw from oats or barley, and should be seed free to prevent introduction of weeds as defined by the rules and regulations of the North Dakota Department of Agriculture.

At least 50% of the mulch by weight should be 10 inches or more in length.

**Placement**

The mulch should be machine blown and should be uniformly distributed over the seeded areas. The machine should be of a design that minimizes cutting or breaking of the mulching material.

Mulching operations should not be performed during periods of excessively high winds, which would preclude the proper placing of the mulch.

Mulch containing excessive moisture which prevents uniform feeding through the machine should not be used.

Bales should be broken up and loosened as they are fed into the blower to avoid placement of matted or unbroken lumps.

**Installation**

The mulch should be placed within 24 hours after the seeding has been completed.

The mulch should be placed uniformly over the seeded areas at the rate of 2 tons per acre.

Approximately 10% of the soil surface should be visible through the mulch blanket before the mulch tiller (punching) operation.

**Maintenance**

<b>Problem</b>	<b>Corrective Maintenance</b>
Rills or gullies forming	Regrade and reseed, Add additional controls
Bare soil patches	Remulch and/or reseed
Sediment at the toe of the slope	Regrade, Add silt fence or filter dike if next to a body of water



Specification 708.02 , From the North Dakota Department of Transportation Erosion and Sediment Control Handbook



Mulching involves the application of straw or other organic materials to form a temporary, protective soil cover. Mulch protects the soil surface from the forces of raindrop impact and overland flow. Organic mulches foster the growth of vegetation, reduce evaporation, insulates the soil, and suppresses weed growth.

**Materials**

Hydro-mulch contains a wood cellulose fiber that has not been treated with any germination or growth inhibitive substance but will be treated with a tackifier to enhance seed and mulch placement and adherence to the soil. The mulch should be free of contamination from noxious weed seed and seed from competitive plants.

**Placement**

The mulch should be uniformly applied at a rate of one ton per acre and should cover a minimum of 95% of the seedbed area. After application, the mulch should permit percolation of water to the underlying soil.

**Maintenance**

Hydro-mulching is generally maintenance free.

**Removal**

Mulching does not need to be removed.



Specification 708.02 , From the North  
Dakota Department of Transportation  
Erosion and Sediment Control Handbook



Appendix 3  
Detail 10 –Hydro-Mulch

**APPENDIX 4**

**HYDROVAC SPOIL DISCHARGE SPECIFICATION**



## HYDROVAC & EXCAVATION SPOIL DISCHARGE SPECIFICATION

### I. PURPOSE

To provide site personnel with guidance for Hydrovac spoil discharge

### II. SCOPE

Applicable to all site personnel located in North Dakota

### III. DISCHARGE SPECIFICATIONS

Hydrovac spoil discharge is prohibited by the following:

A. Color - A qualified person should inspect spoils for evidence of discoloration. If pollutants are present, spoils must be disposed of at an approved disposal facility.

B. Odor – A qualified person should inspect spoils for evidence of a hydrocarbon smell (i.e. oil or gas). If pollutants are present, spoils must be disposed of at an approved disposal facility.

C. Sheen – A qualified person should visually inspect spoils for evidence of oil sheen. If pollutants are present, spoils must be disposed of at an approved disposal facility.

### IV. DISCHARGE LIMITATIONS

Hydrovac Spoils are limited to the appropriate retention area. Retention area should be a minimum 15' from the edge of pad location and no closer than 2' from the edge of the hydrovaced area. Operator should consider constructing berm to hold spoils in place until spoils are dry.

Spoils must dry in place and liquids may not leave site. If there is potential for liquids to leave site, operator must dispose of spoils at an approved disposal facility. Spoils leaving designated area are considered an "illicit" discharge and violate Federal and State regulations. Contact the ND Regulatory Department prior to taking spoils to a disposal facility as approved facilities may change over time.

### V. EXCEPTIONS

If there are any exceptions, seek an EHS or Regulatory professional for further assistance.



# HYDROVAC & EXCAVATION SPOIL DISCHARGE SPECIFICATION

## VI. PROCESS FLOW CHART

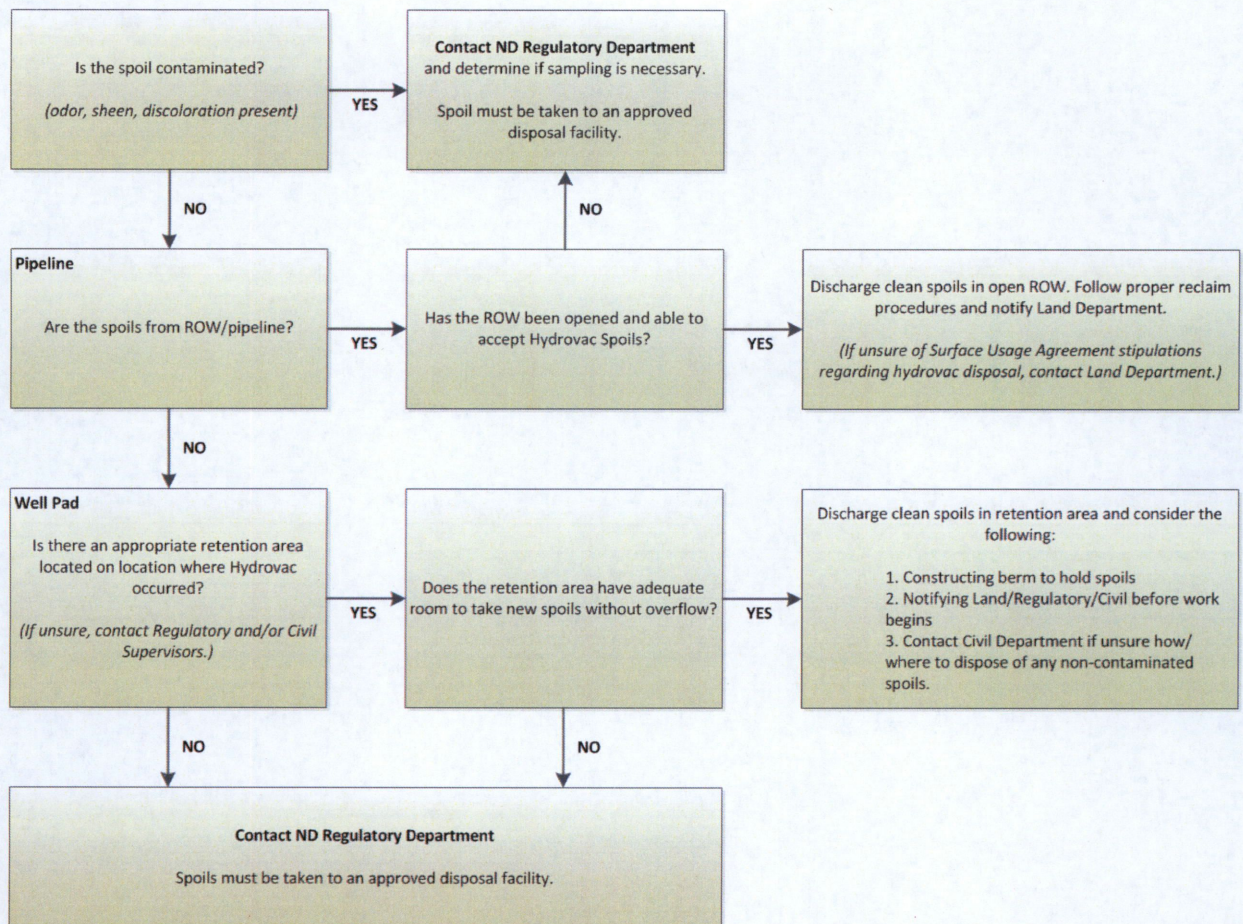

### Acceptable Disposal Practice:

- Onsite in approved spoils containment—if spoils are not contaminated
- If containment is unavailable or full—spoils must be taken to disposal

### Unauthorized Practice

- Disposal on site without authorized containment
- Disposal into dry cuttings pits
- Disposal into SWDD/SPCC or any other pad drainage features
- Disposal on other locations without approval

### Contacts:

**ND Regulatory:** Stetson Sannes  
**Civil NoR:** Bedo Juarez  
**Civil SoR:** Kyle Keighley  
**Land:** Bruce Mackay  
**Pipeline ROW:** Rashan Clark

701-420-7002  
 701-509-5836  
 701-389-7525  
 701-420-6938  
 701-420-7010

ssannes@hess.com  
 bjuarez@ksilp.com  
 kkeighley@hess.com  
 rmackay@hess.com  
 raclark@hess.com

**APPENDIX 5**

**INSPECTION DOCUMENT**



## SWPPP Inspection Process Flowchart

- Use this flowchart to determine when SWPPP inspections warranted

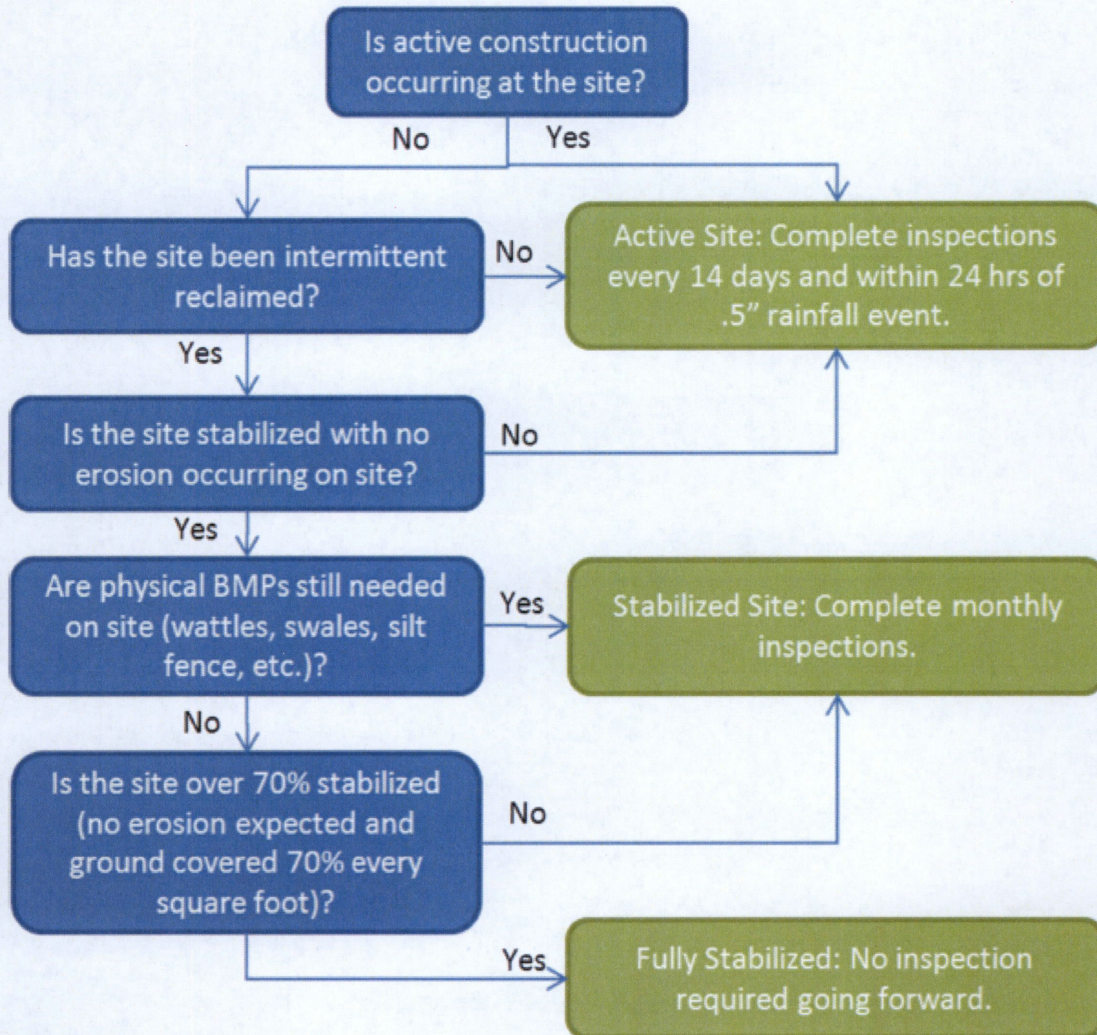

### Site Status:

#### Active:

- includes active construction areas
- includes site prior to intermittent reclaim
- any site experiencing current erosion/sediment issues
- inspections every 14 days and every .5" rainfall event
- BMPs present

#### Stabilized:

- no erosion/sediment issues
- less than 70% vegetation in every square foot (not including weeds)
- after intermittent reclaim
- should have moderate grass growth
- inspections monthly and every .5" rainfall event
- minimal BMPs present

#### Fully Stabilized:

- no erosion/sediment issues
- over 70% vegetation in every square foot (not including weeds)
- after intermittent reclaim
- inspections may be discontinued
- no BMPs present



**SWPPP Inspection Record**  
**HBIC II**  
 3015 16<sup>th</sup> St. SW, Suite 20  
 Minot, ND 58701

Wellsite/Pipeline: \_\_\_\_\_  
 Inspector: \_\_\_\_\_  
 Inspection Date: \_\_\_\_\_  
 Time: \_\_\_\_\_

Precipitation Amount (If Applicable): \_\_\_\_\_ Precipitation Date: \_\_\_\_\_

- Site Status\*:  Active Site  
 Stabilized Site  
 Fully Stabilized Site (Over 70% vegetated every square foot)

\*Reference the SWPPP Inspection Process Flowchart in Appendix 4-2 of Master SWPPP plan for more information.

<input type="checkbox"/> Y <input type="checkbox"/> N	Is there evidence of, or the potential for sediment or pollutants entering drainage systems or waters of the state?
<input type="checkbox"/> Y <input type="checkbox"/> N	Have BMPs been implemented according to the current SWPPP?
<input type="checkbox"/> Y <input type="checkbox"/> N	Are BMPs effective in minimizing the discharge of sediment from the site?
<input type="checkbox"/> Y <input type="checkbox"/> N	Do BMPs need to be adjusted or additional BMPs needed?
<input type="checkbox"/> Y <input type="checkbox"/> N	Are litter, debris, chemicals, and parts being managed properly to minimize storm water pollution?
<input type="checkbox"/> Y <input type="checkbox"/> N <input type="checkbox"/> N/A	Are there any devices where sediment accumulation has reached 1/2 height or higher (silt fences, fiber rolls, etc.)?
<input type="checkbox"/> Y <input type="checkbox"/> N <input type="checkbox"/> N/A	Are there sediment basins where collected sediment has accumulated more than 1/2?
<input type="checkbox"/> Y <input type="checkbox"/> N <input type="checkbox"/> N/A	Is there evidence of sediment being tracked offsite?
<input type="checkbox"/> Y <input type="checkbox"/> N <input type="checkbox"/> N/A	Is proper containment being used around liquid of soluble materials (oil, fuel, paint, etc)?
<input type="checkbox"/> Y <input type="checkbox"/> N <input type="checkbox"/> N/A	Is storm water flowing evenly over vegetative buffer?
<input type="checkbox"/> Y <input type="checkbox"/> N <input type="checkbox"/> N/A	Are permanent storm water management measures working properly?

**Inspection Findings/Corrective Action Recommendations:**

---



---



---



---

<input type="checkbox"/> Y <input type="checkbox"/> N	Has a Hess representative received a copy of this inspection?
---	---

Please email digital copy of completed above portion to [ndregulatory@hess.com](mailto:ndregulatory@hess.com). Email title should be structured SWPPP-Date-HessArea.

**Following to be completed by a Hess Representative:**

Corrective Actions Taken (Silt fence/fiber roll sediment removal or repair, removal of sediment tracked or deposited off-site, spill or leak clean-up, etc):

Date:	Time:	Responsible Party:	Corrective Action Summary:

**SWPPP Update Comments/Recommendations:**

---



---

**ATTACHMENT 1**

NDR10-0000

Permit No: NDR10-0000  
Effective Date: April 01, 2015  
Expiration Date: March 31, 2020

AUTHORIZATION TO DISCHARGE UNDER THE  
NORTH DAKOTA POLLUTANT DISCHARGE ELIMINATION SYSTEM

In compliance with Chapter 33-16-01 of the North Dakota Department of Health rules as promulgated under Chapter 61-28 (North Dakota Water Pollution Control Act) of the North Dakota Century Code,

Facilities both qualifying for and satisfying the requirements identified in Part I of the permit are authorized to discharge stormwater associated with **construction activity**

to waters of the state

in accordance with conditions set forth in this permit.

This permit and the authorization to discharge shall expire at midnight,

March 31, 2020.

Signed this 31 day of March, 2015.



Karl H. Rockeman, P.E.  
Director  
Division of Water Quality

Table of Contents

I.	PERMIT COVERAGE AND LIMITATIONS .....	3
A.	Discharges Covered .....	3
B.	Discharges Not Covered .....	4
C.	Obtaining Coverage and Authorization Effective Date .....	4
D.	Application (Notice of Intent) Process .....	5
E.	Notice of Termination (NOT) .....	6
F.	Transfer of Ownership or Control .....	6
II.	STORMWATER DISCHARGE REQUIREMENTS .....	7
A.	Prohibition of Non-Stormwater Discharges .....	7
B.	Releases in Excess of Reportable Quantities .....	7
C.	Stormwater Pollution Prevention Plans .....	7
D.	Local Requirements .....	13
E.	Final Stabilization .....	13
III.	SELF MONITORING AND REPORTING .....	14
A.	Inspection and Maintenance Requirements .....	14
B.	Records Location .....	16
IV.	STANDARD CONDITIONS .....	17
A.	COMPLIANCE RESPONSIBILITIES .....	17
B.	GENERAL REQUIREMENTS .....	20
V.	DEFINITIONS .....	22
	Appendix 1 – Erosion and Sediment Control Requirements .....	25

## I. PERMIT COVERAGE AND LIMITATIONS

### A. Discharges Covered

1. This permit applies to all areas within the state of North Dakota, except for those areas defined as Indian Country. Construction activity located within Indian Country within the state of North Dakota must obtain a permit through the United States Environmental Protection Agency. If the construction activity is located with the jurisdiction of the state of North Dakota, and the United States Environmental Protection Agency, a permit must be obtained from both regulatory entities.
2. This permit applies to stormwater discharges associated with construction activity and small construction activity as defined in Title 40 of the Code of Federal Regulations (CFR), Parts 122.26(b)(14)(x) and (b)(15), respectively. The reference to construction activity in this permit includes both large construction activity and small construction activity as described below.
  - a. Large construction activity includes clearing, grading and excavation, that disturbs land of equal to or greater than five (5) acres and includes the disturbance of less than five (5) acres of total land area that is a part of a larger common plan of development or sale if the larger common plan will ultimately disturb five (5) acres or more.
  - b. Small construction activity includes clearing, grading and excavation, that disturbs land of equal to or greater than one (1) acre, and includes the disturbance of less than one (1) acre of total land area that is part of a larger common plan of development or sale if the larger common plan will ultimately disturb equal to or greater that one (1) and less than five (5) acres.
  - c. Discharges of stormwater from oil and gas exploration, production, processing or treatment operations, or transmission facilities composed of contaminated runoff by contact with or that has come into contact with, any overburden, raw material, intermediate products, finished product, byproduct, or waste products located on the site of such operations.
3. Stormwater discharges from support activities (e.g., equipment staging yards, material storage areas, excavated material disposal areas, borrow areas) may be covered by this permit as part of a related construction site. The support activities may only be in association with one project. If the support activity is associated with more than one project, a separate stormwater permit (Industrial or mining, extraction or paving material preparation) is required.
4. Certain non-stormwater discharges from facilities covered by this permit and meeting the requirements specified in Part II(A).
5. Stormwater discharges from construction activity covered by the previous permit, issued October 12, 2009, where a notice has been submitted to obtain coverage under this permit.
6. Projects which have obtained coverage under this permit shall amend and implement a Stormwater Pollution Prevention Plan (SWPPP) that meets the requirements of this permit within ninety (90) days of the effective date of this permit.
7. Discharges from dewatering activities related to construction activities (discharges of uncontaminated stormwater).
8. Local Authority. This permit does not preempt or supersede the authority of local agencies or operators of municipal separate storm sewer systems to prohibit, restrict, or control discharges of stormwater to storm sewer systems or other water courses within their jurisdiction.

## **B. Discharges Not Covered**

1. Stormwater discharges associated with industrial activity from any source other than construction activities described in Part I(A).
2. Post-construction discharges from industrial activity that originate from the site after construction activities have been completed at the site. Industrial and post-construction stormwater discharges may need to be covered by a separate stormwater permit.
3. The placement of fill into waters of the state requiring local, state, or federal authorizations (such as U.S. Army Corps of Engineers Section 404 permits).
4. This permit does not substitute for obligations under the National Environmental Policy Act (NEPA), Endangered Species Act (ESA), Wild and Scenic Rivers Act, or National Historic Preservation Act (NHPA), it is your responsibility to ensure the project and resulting discharges comply with the respective requirements.
5. Discharges to waters for which there is a total maximum daily load (TMDL) allocation for sediment and/or parameters associated with sediment transport are not covered unless you develop a Stormwater Pollution Prevention plan (SWPPP) that is consistent with the assumptions and requirements in the approved TMDL. To be eligible for coverage under this general permit, the SWPPP must incorporate the conditions applicable to the discharge necessary for consistency with the assumptions, allocations and requirements of the TMDL. If a specific numeric wasteload allocation has been established that would apply to discharges from construction activity, the permittee must incorporate that allocation into the SWPPP and implement necessary steps to meet that allocation. Information about TMDL allocations may be found at the following website:  
[www.ndhealth.gov/WQ/SW/Z2\\_TMDL/default.htm](http://www.ndhealth.gov/WQ/SW/Z2_TMDL/default.htm).
6. Stormwater discharges that the department determines will cause, or have the reasonable potential to cause or contribute to a violation of the standards for quality for waters of the state (North Dakota Administrative Code (N.D.A.C.) 33-16-02.1).
7. Discharges from hydrostatic testing, well points, water line disinfection and treatment of gasoline or diesel contaminated groundwater.
8. Discharges of wash water using detergents, wastewater, or sanitary waste.

## **C. Obtaining Coverage and Authorization Effective Date**

1. To obtain authorization under this general permit for stormwater discharges you must submit a complete application and develop a SWPPP in accordance with Part II(C) of this permit. A SWPPP must be in place as a condition of the permit and a copy of the SWPPP must be retained by the permittee.
2. Permit coverage will become effective seven (7) days after you submit a complete application unless otherwise notified by the department (based on the department receipt date).
3. Upon the effective date of permit coverage you, as the permit applicant, are authorized to discharge stormwater from eligible activities under the terms and conditions of this permit.

#### D. Application (Notice of Intent) Process

1. You must use a Notice of Intent (NOI) to complete your application. An NOI form (or a replacement application form) is available at the following website:  
[www.ndhealth.gov/WQ/Storm/Construction/ConstructionHome.htm](http://www.ndhealth.gov/WQ/Storm/Construction/ConstructionHome.htm).
2. Application Content and Conditions.
  - a. The owner, or owner jointly with the operator (usually the general contractor), shall submit a completed application for this permit. The owner is responsible for compliance with all terms and conditions of this permit. The operator has day to day supervision of construction activities and is jointly responsible with the owner for compliance with the permit conditions as they pertain to the construction activities delegated to the operator.
  - b. The application (Notice of Intent) shall contain, at a minimum, the following information:
    - (1) Owner name, mailing address and phone number;
    - (2) Project contact name and phone number;
    - (3) Project/site name;
    - (4) Project/site location (street address; section, township, range; or latitude and longitude) and county;
    - (5) A brief description of the construction activity;
    - (6) The anticipated start date and the anticipated completion date for the project (if known);
    - (7) The estimated total area of the site and the total area of disturbance in acres;
    - (8) The name of receiving water(s), or the name of the municipal storm sewer system and receiving water(s);
    - (9) The signature of the applicant(s), owner (and operator if co-applicants) signed in accordance with the signatory requirements in Part IV(A)(6) of this permit.
  - c. A SWPPP (Part II(C)) for the project must be prepared and available for review, upon request, by the department at the time of application. A partially complete plan is acceptable when it clearly identifies the item(s) to be completed, the person(s) responsible for completing the item(s) and the deadline for completing the item(s). The SWPPP must be completed prior to the start of construction (or the applicable construction phase). You are not required to submit the SWPPP with the application unless otherwise notified by the department.
3. For residential construction activity occurring within a common plan of development (such as a subdivision) subject to the permit requirements, coverage may be obtained by the following:
  - a. The owner of the lot(s) shall submit one (1) NOI for all of the owner's construction activity within the common plan of development, or
  - b. The operator, such as a homebuilder who may represent one (1) or more lot owners, shall submit one (1) NOI for all of the operator's construction activity within each addition of the common plan of development.

In addition, a SWPPP must be developed and implemented for the permittee's activities within the common plan of development. Additional phases of the common plan of development may be included under the initial application and permit coverage provided the SWPPP is amended to include the additional area or phases.

4. For oil and gas exploration, production, processing, treatment operations, or transmission facilities, which discharge contaminated stormwater, permit applications may be submitted for individual project sites or for an area of operations such as well field or by county.
5. Completed applications and any reports required by this permit shall be submitted to:

North Dakota Department of Health  
Division of Water Quality  
918 East Divide Avenue  
Bismarck, ND 58501-1947

#### **E. Notice of Termination (NOT)**

1. Permittees wishing to terminate coverage under this permit must submit a Notice of Termination (NOT) or other written request identifying the facility, reason why the permit is no longer needed and signed in accordance with Part IV(A)(6) of this permit. Compliance with the conditions of this permit is required until a NOT is submitted to the department.
2. Permittees may only submit a NOT after one of the following conditions have been met:
  - a. Final stabilization (Part II(E)) has been achieved on all portions of the site for which the permittee is responsible.
  - b. Another owner/operator/permittee has assumed control, in accordance with the transfer provisions (Part I(F)), over all areas of the site that have not achieved final stabilization.
  - c. For residential construction only, a NOT is not required for each lot that is sold, transferred, or has achieved final stabilization. The permittee must modify their SWPPP to indicate that permit coverage is no longer required for that lot. The SWPPP shall indicate the reason why coverage is no longer needed and the date the lot was sold, transferred, or achieved final stabilization. In order to terminate coverage, all lots under the control of the owner or operator must be sold, transferred, or achieved final stabilization (Part II(E)).

#### **F. Transfer of Ownership or Control**

1. When the owner or operator of a construction project changes, the new owner or operator must submit a written request for permit transfer/modification within fourteen (14) days of assuming control of the site or commencing work on-site, or of the legal transfer, sale or closing on the property; except as provided in Part I(F)(2). Late submittals will not be rejected; however the department reserves the right to take enforcement for any unpermitted discharges or permit noncompliance. For stormwater discharges from construction activities where the owner or operator changes, the new owner or operator can implement the original SWPPP created for the project or develop and implement their own SWPPP. Permittee(s) shall ensure either directly or through coordination with other operators that their SWPPP meets all terms and conditions of this permit and that their activities do not interfere with another party's erosion and sediment control practices.
2. A permit transfer/modification request is not required for the legal transfer, sale or closing on a property between permittees covered by this permit. Examples include the sale of a property parcel from a developer to a builder, or the transfer of an easement from a developer to a local government authority. If the new party is not covered by this permit at the time of transfer or sale, then the new owner/operator must submit a completed application/NOI within 14 days of assuming control of the site.

## II. STORMWATER DISCHARGE REQUIREMENTS

### A. Prohibition of Non-Stormwater Discharges

The discharge of wastewater is not authorized by this permit. The following sources of non-stormwater discharges are allowed if they are not a significant source of pollution and are identified in the SWPPP: fire-fighting, fire hydrant flushing, potable water line flushing, equipment wash down without detergents or hazardous cleaning products, uncontaminated foundation drains, springs, surface water, lawn watering, chemical treatment of stormwater and air conditioning condensate. Impervious surface wash water may not be directed into any surface water or storm drain inlet unless appropriate pollution prevention measures have been implemented. Discharges may not come into contact with oil and grease deposits or any other toxic or hazardous materials (unless cleaned up using dry clean-up methods). The SWPPP must include a description of the pollution prevention measures to be implemented while non-stormwater discharges are occurring.

If chemical treatment for sediment removal is intended to be used on-site, the permittee shall provide the department with the information outlined in Appendix 1(A)(14) of this permit for approval prior to use. This information shall be provided to the department no later than sixty (60) days prior to use.

### B. Releases in Excess of Reportable Quantities

This permit does not relieve the permittee of the reporting requirements of 40 CFR 110, 40 CFR 117, and 40 CFR 302, nor the reporting requirements found in Chapter 33-16-02.1 of the North Dakota Administrative Code. Any releases which meet any reporting requirement, must be reported to the agencies identified in Part IV(A)(7).

### C. Stormwater Pollution Prevention Plans

All permittees shall implement a SWPPP for any construction activity requiring this permit until final stabilization is achieved. The SWPPP and revisions are subject to review by the department. The objectives of the SWPPP is to identify potential sources of sediment and other sources of pollution associated with construction activity, and to ensure practices are implemented and maintained to reduce the contribution of pollutants in stormwater discharges from the construction site to waters of the state and storm sewer systems. Stormwater management documents developed under other regulatory programs may be included or incorporated by reference in the SWPPP, or used in whole as a SWPPP if it meets the requirements of this part.

The SWPPP may identify more than one permittee and may specify the responsibilities of each permittee by task, area, and/or timing. Permittees may coordinate and prepare more than one SWPPP to accomplish this. However, in the event there is a requirement under the SWPPP for which responsibility is ambiguous or is not included in the SWPPP, each permittee shall be responsible for implementation of that requirement. Each permittee is responsible for assuring that their activities do not render another permittee's controls ineffective.

The SWPPP must incorporate the requirements provided in Appendix 1 and shall include the following information.

1. **Site Description.** Each plan shall provide a description of the construction activity and potential sources of pollution as indicated below:
  - a. A description of the overall project and the type of construction activity;

- b. Estimates of the total area of the site and the total area that is expected to be disturbed by excavation, grading, grubbing, or other activities during the life of the project;
- c. A proposed timetable/schedule, or chart, of activities that includes major phases/stages, BMP implementation, BMP removal, disturbances, and stabilization for major portions of the site;
- d. A description of the soil within the disturbed area(s);
- e. The name of the surface water(s) and municipal storm sewer system at or near the disturbed area that will receive stormwater runoff from the project site; and
- f. A site map which indicates the following items as applicable (more than one (1) map may be needed). If an item is not applicable, provide rationale describing why the item is not applicable to the construction activity:
  - 1) Project boundaries;
  - 2) Areas of ground disturbance during each phase/stage of the project;
  - 3) Areas where disturbance will not occur, such as avoidance areas (e.g. wetlands, critical habitat, Threatened and Endangered Species, etc);
  - 4) Drainage patterns including: flow direction (run-on and runoff);
  - 5) Dividing lines, discharge points, and storm sewer system inlets which the site drains to or may be affected by the activity;
  - 6) Pre-existing and final grades;
  - 7) Location of all temporary and permanent sediment and erosion controls during each particular phase;
  - 8) Location of any stormwater conveyances such as: retention ponds, detention ponds, ditches, pipes, swales, stormwater diversions, culverts, and ditch blocks;
  - 9) Location of potential sources of pollution (e.g. portable toilets, trash receptacles, etc.);
  - 10) Location of soil stockpiles;
  - 11) Identify steep slopes;
  - 12) Surface waters, including an aerial extent of wetland acreage;
  - 13) Location of surface water crossings;
  - 14) Locations where stormwater is discharged to surface waters;
  - 15) Location of dewatering discharge points;
  - 16) Locations of where chemical treatment of stormwater will be performed, including discharge points;
  - 17) Fueling locations, vehicle and equipment maintenance areas, designated wash water collection site, lubricant and chemical storage, paint storage, material storage, staging areas, and debris collection area;
  - 18) Location of any impervious surfaces upon completion of construction; and
  - 19) Where included as part of the project, the site maps for off-site concrete/asphalt batch plants, equipment staging areas, borrow sites or excavated fill material disposal sites. Site maps must show items 1 through 18 of this section.
- g. Projects that discharge stormwater which flows to a water body listed as impaired under section 303(d) of the Federal Clean Water Act due to sediment, suspended solids or turbidity must identify the water body and impairment in the SWPPP. The Department's 303(d) list may be found at the following website under Integrated Reports:  
[www.ndhealth.gov/WQ/SW/Z2\\_TMDL/Integrated Reports/B Integrated Reports.htm](http://www.ndhealth.gov/WQ/SW/Z2_TMDL/Integrated_Reports/B_Integrated_Reports.htm).
- h. For water bodies which have a TMDL, the SWPPP must describe and conform to the Waste Load Allocations (WLA) of the water body as per Part II(C)(4)(g) of this permit. Information about TMDL allocations may be found at the following website:  
[www.ndhealth.gov/WQ/SW/Z2\\_TMDL/default.htm](http://www.ndhealth.gov/WQ/SW/Z2_TMDL/default.htm).

2. **Narrative.** The SWPPP must include a narrative description of the selected operational controls and sediment and erosion controls as outlined in Part II(C)(3), Part II(C)(4), and Appendix 1 of this permit. When applicable, a description of the requirements for any additional environmental regulations (federal) and local requirements related to the project, as it relates to waters of the state, must also be included or incorporated by reference (e.g. The Wild and Scenic Rivers Act, The National Historic Preservation Act, The Endangered Species Act, Fish and Wildlife Coordination Act, National Environmental Policy Act, Section 404 of the Clean Water Act, etc.).

The narrative shall describe at a minimum:

- a. The installation, removal (if applicable), and maintenance requirements of selected Best Management Practices (BMPs) for each phase/stage of construction activity;
  - b. The rationale for the selection of all BMPs (calculations should be included if appropriate);
  - c. Whether selected BMPs are temporary or permanent;
  - d. Any descriptions of infeasibility or explanations as required in Part II, Part III(A), and Appendix 1 of this permit.
3. **Operational Controls.** The SWPPP shall describe the BMPs used in day to day operations on the project site that reduce the contribution of pollutants in stormwater runoff.

- a. The SWPPP must identify a person knowledgeable and experienced in the application of erosion and sediment control BMPs who will oversee the implementation of the SWPPP, and the installation, inspection and maintenance of the erosion and sediment control BMPs before and during construction, until a NOT is filed or the permit is transferred. A knowledgeable and experienced person is someone who meets the requirements of Part II(C)(3)(e) of this permit.

The owner shall develop a chain of responsibility with all operators on the site to ensure that the SWPPP will be implemented and stay in effect until the construction project is complete, the entire site has undergone final stabilization, and a NOT has been submitted to the department.

- b. The SWPPP must include a description of good housekeeping practices used to maintain a clean and orderly site. The SWPPP shall describe how litter, debris, chemicals and parts will be handled to minimize exposure to stormwater. The SWPPP also shall describe what measures will be used to reduce and remove sediment tracked off-site by vehicles or equipment. In addition, the SWPPP shall describe methods which will be used to reduce the generation of dust.
- c. The SWPPP shall describe preventative maintenance practices used to ensure the proper operation of erosion and sediment control devices (e.g., fiber rolls, erosion control blankets and silt fences) and equipment used or stored on site. The SWPPP shall describe proper inspection procedures for ensuring proper operation of erosion and sediment control devices.
- d. The SWPPP shall describe spill prevention and response procedures where potential spills can occur. Specific handling procedures, storage requirements, spill containment, cleanup procedures, and disposal must be identified. Storage structures for petroleum products and other chemicals shall have adequate leak and spill protection to prevent any spilled materials from entering waters of the state or storm sewer systems.

The potential discharge of hazardous substances in stormwater discharges shall be minimized by including measures onsite, detailed in the SWPPP to prevent and respond to releases of hazardous substances. If a reportable quantity release occurs, the SWPPP shall be revised to prevent the reoccurrence of such a release.

- e. The SWPPP shall outline how employees and responsible parties shall be trained on the implementation of the SWPPP. Training must be provided at least annually, as new employees or responsible parties are hired or as necessary to ensure compliance with the SWPPP and the general permit. Employees and responsible parties include individuals who are responsible for design, installation, maintenance and repair of stormwater controls and conducting inspections.
- 1) On-site personnel must understand the requirements of this permit as it pertains to their role in implementing the SWPPP. On-site personnel must know:
    - a. The purpose of the SWPPP, requirements of the SWPPP, and how the SWPPP will be implemented;
    - b. The location of all BMPs identified in the SWPPP; and
    - c. Correct installation, function, maintenance and removal (if applicable) of BMPs identified in the SWPPP.
  - 2) Personnel responsible for performing site inspections must understand when inspections must be conducted (Part III(A)), what must be inspected (Part II(C)(7)), how to record findings, when to initiate corrective actions, and properly document corrective actions.
  - 3) Maintenance personnel must understand when maintenance must be performed on BMPs in order to maintain properly functioning BMPs and what needs to be recorded for corrective actions/maintenance records in accordance with Part III(A)(5) of this permit.
- f. The SWPPP must describe how concrete grindings and slurry will be managed. Wastewater from concrete washout, cleanout or washout from: stucco, paint, joint compound, and other building materials shall not be discharged to waters of the state, storm sewer systems or curb and gutter systems.
- 1) Wash water must be collected in leak-proof containers or leak-proof pits. Containers or pits must be designed and maintained so that overflows cannot occur due to inadequate sizing, precipitation events, or snowmelt.
- g. The SWPPP shall describe any dewatering activities planned at the site. Dewatering or basin draining (e.g., pumped discharges, trench/ditch cuts for drainage) related to the permitted activity must be managed with appropriate BMPs, such that the discharge does not adversely affect the receiving water. The following conditions apply to dewatering activities:
- 1) Dewatering is limited to un-contaminated stormwater, surface water, and groundwater that may collect on-site and those sources identified in Part II(A), if they are not a significant source of pollution. A separate permit must be obtained to discharge water from other sources such as hydrostatic testing of pipes, tanks, or other similar vessels; disinfection of potable water lines; pump testing of water wells; and the treatment of gasoline or diesel contaminated groundwater or surface water.
  - 2) The permittee(s) must operate the discharge to minimize the release of sediment and provide adequate BMPs where necessary to minimize erosion due to the discharge. Discharges must not lead to the deposition of sediment within stormwater conveyance systems or surface waters. Discharges must not cause or potentially cause a visible plume within a surface water body.

- 3) When dewatering, utilize structures or BMPs which allow for draw down to occur from the surface of the water, unless infeasible. If infeasible, documentation must be provided in the SWPPP. In addition, you must describe what BMP(s) will be used in its place.
- 4) In addition to the inspection requirements in Part III, dewatering activities shall be inspected daily. The inspection must include the dewatering site, areas where BMPs are being implemented and the discharge location. A record shall be maintained to document the inspections of the dewatering operation and actions taken to correct any problems that may be identified.

a. Records shall contain at a minimum:

- i. Date and time of the inspection,
- ii. Inspector name,
- iii. Approximate volume of water discharged,
- iv. Findings of the inspection, including recommendations and schedule for corrective actions;
- v. Corrective actions taken (including dates, times, and party completing maintenance activities); and
- vi. Documentation that the SWPPP has been amended when changes are made to the dewatering activity in response to inspections.

- 5) Local authorities may require specific BMPs for discharges affecting their storm sewer system.

4. **Erosion and Sediment Controls.** Erosion and sediment controls and stabilization requirements must be implemented for each major phase of site activity (e.g., clearing, grading, building, and landscaping phases). A description of the erosion and sediment controls and site stabilization methods must be provided in accordance with Part II(C)(2) of this permit. Erosion and sediment controls, and site stabilization must conform to the requirements provided in Appendix 1. The description and implementation of controls shall address the following minimum components:

a. The selection of erosion and sediment controls, and site stabilization shall consider the following:

1. The expected amount, frequency, intensity, and duration of precipitation events;
2. The nature of stormwater run-on and runoff from the site as well as changes during, and as a result of, construction activity. This includes changes to impervious surfaces, slopes, seasonal changes, and drainage features on-site;
3. Channelized flow, must be handled in order to minimize erosion at outlets and to minimize impacts to downstream receiving waters;
4. Soil types (wind and water erodibility, and settling time); and
5. Seasonal conditions.

b. Sediment basins, or an appropriate combination of equivalent sediment controls such as smaller sediment basins and/or sediment traps, silt fences, fiber logs, vegetative buffer strips, berms, etc., are required for all down slope boundaries of the disturbance area and for those side slope boundaries as may be appropriate for site conditions.

- c. Temporary or permanent erosion protection and stabilization (such as cover crop planting or mulching) must be initiated immediately, as described in Appendix 1(A), for all exposed soil areas where activities have been completed or temporarily ceased.
- d. All control measures must be properly selected, installed and maintained in accordance with the manufacturer's specifications and good engineering practices. If periodic inspections or other information indicates a control has been used inappropriately or incorrectly, the permittee must replace or modify the control for site situations. Corrective actions must be made prior to the next anticipated rainfall event of within 24 hours of discovery (whichever comes first) or as soon as field conditions allow. Documentation must be provided in the maintenance records if field conditions do not allow access along with a plan of action for performing maintenance activities.

The permittee may deviate from the manufacturer's specifications and erosion and sediment control requirements in Appendix 1 if they provide justification for the deviation and document the rationale for the deviation in the SWPPP. Any deviation must provide equivalent erosion and sediment control.

- e. If sediment escapes from the site, off-site accumulations of sediment must be removed in a manner and frequency sufficient to minimize off-site impacts as outlined in Appendix 1(B). The SWPPP must be modified to prevent further sediment deposition off-site.
  - f. Stormwater controls are expected to withstand and function properly during precipitation events of up to the 2-year, 24-hour storm event. Visible erosion and/or off-site sediment deposition from such storm events should be minimal. The 2-year, 24-hour rainfall event in North Dakota ranges from about 1.9 inches in the west to 2.3 inches in the east.
  - g. For projects that discharge stormwater which flows to a water body for which there is a TMDL allocation for sediment and/or parameters associated with sediment transport, the SWPPP must be consistent with the assumptions, allocations, and requirements in the approved TMDL. If a TMDL specifies certain BMPs or controls to meet a WLA applicable to the project's discharges, the BMPs or controls must be incorporated into the SWPPP. Information about TMDL allocations may be found at the following website:  
[www.ndhealth.gov/WQ/SW/Z2\\_TMDL/default.htm](http://www.ndhealth.gov/WQ/SW/Z2_TMDL/default.htm).
5. **Stormwater Management.** The SWPPP must identify permanent practices incorporated into the project to control pollutants in stormwater discharges occurring after construction operations have been completed.
- a. Identify stormwater ponds; flow reduction methods; infiltration of runoff on-site; sequential systems which combine several practices or other post-construction stormwater management features.
  - b. Identify velocity / energy dissipation devices placed at discharge locations and appropriate erosion protection for outfall channels and ditches.
  - c. Maintenance for on-site stormwater management features is the responsibility of the permittee until the NOT is submitted or the feature is accepted by the party responsible for long term maintenance.
  - d. The design, installation and use of stormwater management features must comply with applicable local, state or federal requirements.

6. **Maintenance.** All erosion and sediment control measures and other protective measures identified in the SWPPP must be maintained in effective operating condition. The SWPPP must indicate, as appropriate, the maintenance or clean out interval for sediment controls. If site inspections, required in Part III of this permit, identify BMPs that are not operating effectively, maintenance shall be arranged and accomplished in accordance to Appendix 1 or as soon as practicable.
7. **Inspections.** The SWPPP must provide for site inspections as outlined in Part III. The permittee shall ensure that personnel conducting site inspections are familiar with permit conditions and the proper installation and operation of control measures. Inspectors must be knowledgeable in their role of the SWPPP, as outlined in Part II(C)(3)(e) of this permit. The erosion and sediment control measures and stabilized areas identified in the SWPPP shall be observed to ensure they are operating correctly and in serviceable condition. Inspections shall include areas used for storage of materials, permanent stormwater control measures and vehicle maintenance areas. These areas shall be inspected for evidence of, or the potential for, pollutants entering a drainage system. If necessary, the plan shall be revised based on the observations and deficiencies noted during the inspection.
8. **SWPPP Review and Revisions.**
  - a. The SWPPP shall be signed in accordance with the Signatory Requirements, Part IV(A)(6), and retained on-site for the duration of activity as outlined in Part III(B).
  - b. The permittee shall make the SWPPP available upon request to the department, EPA, or, in the case of discharges to a municipal storm sewer system, the operator of the municipal system.
  - c. The permittee shall amend the SWPPP whenever there is a change in design, construction, operation, maintenance, or BMPs. The SWPPP shall be amended if the plan is found to be ineffective in controlling pollutants present in stormwater. The SWPPP shall be amended as soon as practicable.

#### **D. Local Requirements**

All stormwater discharges must comply with the requirements, policies, or guidelines of municipalities and other local agencies as applicable to the construction site. Any discharges to a storm sewer, ditch or other water course under the jurisdiction of a municipality must comply with any specific conditions or BMPs required by the municipality or agency.

#### **E. Final Stabilization**

The permittee(s) must ensure final stabilization of the site. The permittee(s) should submit a NOT within 30 days after final stabilization has been achieved, or another owner/operator (permittee) has assumed control according to Part I(F) for all areas of the site that have not undergone final stabilization. Final stabilization can be achieved in one of the following ways.

1. All soil disturbing activities at the site have been completed and all soils must be stabilized by a uniform perennial vegetative cover with a density of 70 percent of the pre-existing cover over the entire pervious surface area, or other equivalent means necessary to prevent soil failure under erosive conditions and;
  - a. All drainage ditches, constructed to drain water from the site after construction is complete, must be stabilized to preclude erosion;

- b. All temporary erosion prevention and sediment control BMPs (such as silt fence) must be removed as part of the site final stabilization; and
  - c. The permittee(s) must remove all sediment from conveyances and temporary sedimentation basins that will be used as permanent water quality management basins. Sediment must be stabilized to prevent it from being washed into basins, conveyances or drainage ways discharging off-site or to surface waters. The cleanout of permanent basins must be sufficient to return the basin to design capacity.
2. For areas of the state where the average annual rainfall is less than 20 inches, all soil disturbing activities at the site have been completed and erosion control measures (e.g., degradable rolled erosion control product) and stabilization methods are selected, designed, and installed along with an appropriate seed base to provide erosion control for at least three years and achieve 70 percent of the pre-existing vegetative cover within three (3) years without active maintenance. Sites must meet the criteria outlined in items 1(a), (b), and (c) above.
  3. Disturbed areas on land used for agricultural purposes that are restored to their pre-construction agricultural use are not subject to these final stabilization criteria. If the construction activity removed standing crop, the area must be restored in accordance with the landowner.

Areas disturbed that were not previously used for agricultural activities, such as buffer strips immediately adjacent to waters of the state, and areas which are not being returned to their pre-disturbance use must meet the final stabilization criteria in (1) or (2) above.

4. For residential construction only, final stabilization may be achieved when soil is stabilized (see Appendix 1(A)(3)) and down gradient perimeter control for individual lots has been implemented and the residence has been transferred to the homeowner. Additionally, the permittee must distribute a "homeowner fact sheet" to the homeowner to inform the homeowner of the need for, and benefits of, final stabilization. The permittee also must demonstrate that the homeowner received the fact sheet.

### **III. SELF MONITORING AND REPORTING**

#### **A. Inspection and Maintenance Requirements**

1. Inspections shall be performed by or under the direction of the permittee at least once every 14 calendar days and within 24 hours after any storm event of greater than 0.25 inches of rain per 24-hour period. Inspections are only required during normal working hours. The permittee shall use a rain gauge on-site or utilize the nearest National Weather Service precipitation gauge station. Rain gauge locations or stations must be representative of the site.
  - a. "Within 24 hours after any storm event greater than 0.25 inches rain per 24-hour period" means that you are required to conduct an inspection within 24 hours once a storm event has produced 0.25 inches, even if the storm event is still continuing. If there is a storm event at your site that continues for multiple days, and each day of the storm produces 0.25 inches or more rain, you are required to conduct an inspection within 24 hours of the first day of the storm and within 24 hours after the end of the storm.

2. There may be times when a site inspection may not be practical at the specified time. Adverse climatic conditions, such as flooding, high winds, tornadoes, electrical storms, site access constraints, etc., may prohibit inspections. The permittee must include a description of why the inspection(s) could not be performed at the designated time in the next inspection record. If an inspection is delayed due to adverse weather conditions or rain events outside normal working hours, an inspection must be conducted during the next working day, or as conditions allow.
3. Some erosion and sediment control measures may require more frequent inspection based on location (e.g., sensitive areas or waters of the state) or as a result of recurring maintenance issues. Erosion or sediment control measures found in need of maintenance between inspections must be repaired or supplemented with appropriate measures as soon as practicable. Erosion and sediment control measures which require more frequent inspection based on location or as a result of recurring maintenance issues must be identified in the SWPPP.
4. All inspections conducted during construction must be recorded in writing and these records must be retained in accordance with Part III(B). Records of each inspection activity shall include:
  - a. Date and time of inspections;
  - b. Name of person(s) conducting inspections;
  - c. Findings of inspections, including recommendations and schedule for corrective actions;
  - d. Date and amount of all rainfall events greater than 1/4 inch (0.25 inches) in 24 hours; and
  - e. Documentation that the SWPPP has been amended when changes are made to BMPs in response to inspections.
  - f. All inspection reports shall be signed in accordance with Part IV(A)(6) of this permit.
5. Corrective actions (maintenance activities) performed during construction must be recorded in writing and these records must be retained in accordance with Part III(B). Records for maintenance activity shall include:
  - a. Best Management Practice corrected;
  - b. Date and time of corrective action;
  - c. Name of person(s) performing corrective actions;
  - d. Corrective actions taken; and
  - e. Corrective actions/maintenance records shall be signed in accordance with Part IV(A)(6) of this permit.
6. Completed areas that have been stabilized but do not meet the 70 percent perennial vegetative cover criteria for final stabilization may be inspected once per month. Inspections may be suspended for parts of the construction site that meet final stabilization requirements of Part II(E) of this permit. The SWPPP must update to identify any areas which meet this condition.

7. Inspections may be suspended where earthwork has been suspended due to frozen ground conditions. The required inspections and maintenance must resume as soon as runoff occurs or the ground begins to thaw at the site. The permittee must record freeze/thaw and runoff dates as part of the inspection records.

**B. Records Location**

A copy of the completed and signed NOI, coverage letter from the department, SWPPP, site inspection records, and this general permit shall be kept at the site of the construction activity in a field office, trailer, shed, or in a vehicle that is on-site during normal working hours. If the site does not have a reasonable on-site location, then the documents must be retained at a readily available alternative location; preferably with the individual responsible for overseeing the implementation of the SWPPP. Electronic copies of records are acceptable if the records can be accessed on-site. If the site is inactive, then the documents may be stored at a local office. Permittees should avoid using personal electronic devices for storing electronic records.

#### IV. STANDARD CONDITIONS

##### A. COMPLIANCE RESPONSIBILITIES BP 2014.12.08

**1. Duty to Comply**

The permittee must comply with all conditions of this permit. Any permit noncompliance constitutes a violation of the Act and is grounds for enforcement action; for permit termination, revocation and reissuance, or modification; or for denial of a permit renewal application.

**2. Proper Operation and Maintenance**

The permittee shall at all times maintain in good working order and operate as efficiently as possible all treatment or control facilities or systems installed or used by the permittee to achieve compliance with the terms and conditions of this permit. If necessary to achieve compliance with the conditions of this permit, this shall include the operation and maintenance of backup or auxiliary systems.

**3. Planned Changes**

The department shall be given advance notice of any planned changes at the permitted facility or of an activity which may result in permit noncompliance. Any anticipated facility expansions, production increase, or process modifications which might result in new, different, or increased discharges of pollutants shall be reported to the department as soon as possible. Changes which may result in a facility being designated a "new source" as determined in 40 CFR 122.29(b) shall also be reported.

**4. Duty to Provide Information**

The permittee shall furnish to the department, within a reasonable time, any information which the department may request to determine whether cause exists for modifying, revoking and reissuing, or terminating this permit, or to determine compliance with this permit. The permittee shall also furnish to the department, upon request, copies of records required to be kept by this permit. When a permittee becomes aware that it failed to submit any relevant facts or submitted incorrect information in a permit application or any report, it shall promptly submit such facts or information.

**5. Records Retention**

All records and information (including calibration and maintenance) required by this permit shall be kept for at least three years or longer if requested by the department or EPA.

**6. Signatory Requirements**

All applications, reports, or information submitted to the department shall be signed and certified.

All permit applications shall be signed by a responsible corporate officer, a general partner, or a principal executive officer or ranking elected official.

All reports required by the permit and other information requested by the department shall be signed by a person described above or by a duly authorized representative of that person. A person is a duly authorized representative only if:

- a. The authorization is made in writing by a person described above and submitted to the department; and
- b. The authorization specifies either an individual or a position having responsibility for the overall operation of the regulated facility, such as the position of plant manager, superintendent, position of equivalent responsibility, or an individual or position having overall responsibility for environmental matters.

If an authorization under 6. Signatory Requirements is no longer accurate for any reason, a new authorization satisfying the above requirements must be submitted to the department prior to or together with any reports, information, or applications to be signed by an authorized representative.

Any person signing a document under this section shall make the following certification:

"I certify under penalty of law that this document and all attachments were prepared under my direction or supervision in accordance with a system designed to assure that qualified personnel properly gather and evaluate the information submitted. Based on my inquiry of the person or persons who manage the system, or those persons directly responsible for gathering the information, the information submitted is, to the best of my knowledge and belief, true, accurate, and complete. I am aware that there are significant penalties for submitting false information, including the possibility of fine and imprisonment for knowing violations."

## **7. Twenty-four Hour Notice of Noncompliance Reporting**

1. The permittee shall report any noncompliance which may endanger health or the environment. Any information shall be provided orally as soon as possible, but no later than twenty-four (24) hours from the time the permittee first became aware of the circumstances. The following occurrences of noncompliance shall be included in the oral report to the department at 701.328.5210:
  - a. Any lagoon cell overflow or any unanticipated bypass which exceeds any effluent limitation in the permit under 8. Bypass of Treatment Facilities;
  - b. Any upset which exceeds any effluent limitation in the permit under 9. Upset Conditions; or
  - c. Violation of any daily maximum effluent or instantaneous discharge limitation for any of the pollutants listed in the permit.
2. A written submission shall also be provided within five days of the time that the permittee became aware of the circumstances. The written submission shall contain:
  - a. A description of the noncompliance and its cause;
  - b. The period of noncompliance, including exact dates and times;
  - c. The estimated time noncompliance is expected to continue if it has not been corrected; and
  - d. Steps taken or planned to reduce, eliminate, and prevent recurrence of the noncompliance.

Reports shall be submitted to the address in Part I(D) Application (Notice of Intent) Process. The department may waive the written report on a case by case basis if the oral report has been received within 24 hours by the department at 701.328.5210 as identified above.

All other instances of noncompliance shall be reported no later than at the time of the next Discharge Monitoring Report submittal. The report shall include the four items listed in this subsection.

## **8. Bypass of Treatment Facilities**

1. Bypass not exceeding limitations. The permittee may allow any bypass to occur which does not cause effluent limitations to be exceeded, but only if it also is for essential maintenance to assure efficient operation. These bypasses are not subject to any of the following provisions in this section.

Bypass exceeding limitations-notification requirements.

- a. Anticipated Bypass. If the permittee knows in advance of the need for a bypass, it shall submit prior notice, if possible at least ten (10) days before the date of bypass.
  - b. Unanticipated Bypass. The permittee shall submit notice of an unanticipated bypass as required under 7. Twenty-four Hour Notice of Noncompliance Reporting.
2. Prohibition of Bypass. Bypass is prohibited, and the department may take enforcement action against a permittee for bypass, unless:
- a. Bypass was unavoidable to prevent loss of life, personal injury, or severe property damage;
  - b. There were no feasible alternatives to the bypass, such as the use of auxiliary treatment facilities, retention of untreated wastes, or maintenance during normal periods of equipment downtime. This condition is not satisfied if adequate back-up equipment should have been installed in the exercise of reasonable engineering judgment to prevent a bypass which occurred during normal periods of equipment downtime or preventive maintenance; and
  - c. The permittee submitted notices as required under the 8(a). Anticipated Bypass subsection of this section.

The department may approve an anticipated bypass, after considering its adverse effects, if the department determines that it will meet the three (3) conditions listed above.

**9. Upset Conditions**

An upset constitutes an affirmative defense to an action brought for noncompliance with erosion and sediment or site stabilization methods if the requirements of the following paragraph are met. No determination made during administrative review of claims that noncompliance was caused by upset, and before an action for noncompliance, is final administrative action subject to judicial review.

A permittee who wishes to establish the affirmative defense of upset shall demonstrate, through properly signed, contemporaneous operating logs, or other relevant evidence that:

1. An upset occurred and the permittee can identify its cause(s);
2. The permitted facility was, at the time being, properly operated;
3. The permittee submitted notice of the upset as required under 7. Twenty-four Hour Notice of Noncompliance Reporting and
4. The permittee complied with any remedial measures required under 10. Duty to Mitigate.

In any enforcement proceeding, the permittee seeking to establish the occurrence of an upset has the burden of proof.

**10. Duty to Mitigate**

The permittee shall take all reasonable steps to minimize or prevent any discharge or sludge use or disposal in violation of this permit which has a reasonable likelihood of adversely affecting human health or the environment. The permittee, at the department's request, shall provide accelerated or additional monitoring as necessary to determine the nature and impact of any discharge.

**11. Removed Materials**

Collected screenings, grit, solids, sludges, or other pollutants removed in the course of treatment shall be buried or disposed of in such a manner to prevent any pollutant from entering any waters of the state or creating a health hazard.

**12. Duty to Reapply**

Any request to have this permit renewed should be made 15 days prior to its expiration date.

**B. GENERAL REQUIREMENTS**

**1. Inspection and Entry**

The permittee shall allow department and EPA representatives, at reasonable times and upon the presentation of credentials if requested, to enter the permittee's premises to inspect the construction activity and monitoring equipment, to sample any discharges, and to have access to and copy any records required to be kept by this permit.

**2. Availability of Reports**

Except for data determined to be confidential under 40 CFR Part 2, all reports prepared in accordance with the terms of this permit shall be available for public inspection at the offices of the department and EPA. As required by the Act, permit applications, permits, and effluent data shall not be considered confidential.

**3. Transfers**

This permit is not transferable except upon the filing of a Transfer/Modification request (Part I(F)) by the new party. The current permit holder should inform the new controller, operator, or owner of the existence of this permit and also notify the Department of the possible change.

**4. New Limitations or Prohibitions**

The permittee shall comply with any effluent standards or prohibitions established under Section 306(a), Section 307(a), or Section 405 of the Act for any pollutant (toxic or conventional) present in the discharge or removed substances within the time identified in the regulations even if the permit has not yet been modified to incorporate the requirements.

**5. Permit Actions**

This permit may be modified, revoked and reissued, or terminated for cause. This includes the establishment of limitations or prohibitions based on changes to Water Quality Standards, the development and approval of waste load allocation plans, the development or revision to water quality management plans, or the establishment of prohibitions or more stringent limitations for toxic or conventional pollutants and/or sewage sludges. The filing of a request by the permittee for a permit modification, revocation and reissuance, or termination, or a notification of planned changes or anticipated noncompliance does not stay any permit condition.

**6. Need to Halt or Reduce Activity Not a Defense**

It shall not be a defense for a permittee in an enforcement action that it would have been necessary to halt or reduce the permitted activity in order to maintain compliance with the conditions of this permit.

**7. State Laws**

Nothing in this permit shall be construed to preclude the institution of legal action or relieve the permittee from any responsibilities, liabilities, or penalties established pursuant to any applicable state law or regulation preserved under Section 510 of the Act.

**8. Oil and Hazardous Substance Liability**

Nothing in this permit shall be construed to preclude the institution of any legal action or relieve the permittee from any responsibilities, liabilities, or penalties to which the permittee is or may be subject under Section 311 of the Act.

**9. Property Rights**

The issuance of this permit does not convey any property rights of any sort, nor any exclusive privileges, nor does it authorize any injury to private property or any invasion of personal rights, nor any infringement of federal, state or local laws or regulations.

**10. Severability**

The provisions of this permit are severable, and if any provision of this permit or the application of any provision of this permit to any circumstance is held invalid, the application of such provision to other circumstances and the remainder of this permit shall not be affected thereby.

## V. DEFINITIONS Permit Specific BP 2009.02.05

"303(d) List" or "Section 303(d) List" means a list of North Dakota's water quality-limited waters needing total maximum daily loads or TMDLs developed to comply with section 303(d) of the Clean Water Act. A copy of the latest integrated report is available on the state's web site at:

[www.ndhealth.gov/WQ/SW/Z2\\_TMDL/Integrated\\_Reports/B\\_Integrated\\_Reports.htm](http://www.ndhealth.gov/WQ/SW/Z2_TMDL/Integrated_Reports/B_Integrated_Reports.htm).

"Act" means the Clean Water Act.

"Bankfull" means the channel is filled to the top of one or both of its banks.

"BMP" or "Best Management Practices" means schedules of activities, prohibitions of practices, maintenance procedures, and other management practices to prevent or reduce the pollution of waters of the state. BMPs also include treatment requirements, operating procedures and practices to control construction site runoff, spillage or leaks, sludge or waste disposal, or drainage from raw material storage.

"Bypass" means the intentional diversion of waste streams from any portion of a treatment facility.

"Common Plan of Development or Sale" means a contiguous area where multiple separate and distinct land disturbing activities may be taking place at different times, on different schedules, but under one proposed plan. One plan is broadly defined to include design, permit application, advertisement or physical demarcation indicating that land-disturbing activities may occur.

"Construction Activity" means construction activity as defined in 40 CFR part 122.26(b)(14)(x) and small construction activity as defined in 40 CFR part 122.26(b)(15). This includes a disturbance to the land that results in a change in topography, existing soil cover (both vegetative and non-vegetative), or the existing soil topography that may result in accelerated stormwater runoff, leading to soil erosion and movement of sediment into surface waters or drainage systems. Examples of construction activity may include clearing, grading, filling and excavating. Construction activity includes the disturbance of less than one acre of total land area that is part of a larger common plan of development or sale if the larger common plan will ultimately disturb one (1) acre or more. Construction activity does not include routine maintenance that is performed to maintain the original line and grade, hydraulic capacity, or original purpose of the facility.

"Department" means the North Dakota Department of Health, Division of Water Quality.

"Energy Dissipation" means methods employed at pipe outlets to prevent erosion. Examples include, but are not limited to: concrete aprons, riprap, splash pads, and gabions that are designed to prevent erosion.

"Indian Country" means (1) All land within the limits of any Indian reservation under the jurisdiction of the United States Government, notwithstanding the issuance of any patent, and including rights-of-way running through the reservations; (2) All dependent Indian communities within the borders of the United States whether within the originally or subsequently acquired territory thereof, and whether within or without the limits of a state; and (3) All Indian allotments, the Indian titles to which have not been extinguished, including rights-of-way running through the same.

"Infeasible" means not technologically possible or not economically practicable and achievable in light of best industry practices.

"Immediately" means as soon as practicable, but no later than the end of the next work day, following the day when the earth-disturbing activities have temporarily or permanently ceased.

"Large Construction Activity" means land disturbance of equal to or greater than five (5) acres. Large construction activity also includes the disturbance of less than one acre of total land area that is part of a larger common plan of development or sale, if the larger common plan will ultimately disturb equal to or greater than five acres.

"Normal Wetted Perimeter" means the area of a conveyance, such as a ditch, channel, or pipe that is in contact with water during flow events that are expected to occur once every year.

"Non-Stormwater Discharges" means discharges other than stormwater. The term includes both process and non-process sources. Process wastewater sources that require a separate NDPDES permit include, but are not limited to industrial processes, domestic facilities and cooling water. Non-stormwater sources that may be addressed in this permit include, but are not limited to: fire-fighting, fire hydrant flushing, potable water line flushing, equipment wash down without detergents or hazardous cleaning products, uncontaminated foundation drains, springs, surface water, lawn watering, chemical treatment of stormwater and air conditioning condensate.

"Operator" means the person (usually the general contractor) designated by the owner who has day to day operational control and/or the ability to modify project plans and specifications related to the SWPPP. The person must be knowledgeable in those areas of the permit for which the operator is responsible and must perform those responsibilities in a workmanlike manner.

"Owner" means the person or party possessing the title of the land on which the construction activities will occur; or if the construction activity is for a lease holder, the party or individual identified as the lease holder; or the contracting government agency responsible for the construction activity.

"Permanently Ceased" means clearing and excavation within any area of your construction site that will not include permanent structures has been completed.

"Permanent Cover" means final stabilization. Examples include grass, gravel, asphalt, and concrete.

"Severe Property Damage" means substantial physical damage to property, damage to best management practices which causes them to become inoperable, or substantial and permanent loss of natural resources which can reasonably be expected to occur in the absence of a bypass. Severe property damage does not mean economic loss caused by delays in construction.

"Significant Materials" includes, but is not limited to: raw materials; fuels; materials such as solvents, detergents, and plastic pellets; finished materials such as metallic products; hazardous substances designated under Section 101(14) of CERCLA; any chemical the facility is required to report pursuant to Section 313 of Title III of SARA; fertilizers; pesticides; and waste products such as ashes, slag and sludge that have the potential to be released with stormwater discharges.

"Significant Spills" includes, but is not limited to: releases of oil or hazardous substances in excess of reportable quantities under Section 311 of the Clean Water Act (see 40 CFR 110.10 and CFR 117.21) or Section 102 of CERCLA (see 40 CFR 302.4).

"Small Construction Activity" means land disturbance of equal to or greater than one acre and less than five acres. Small construction activity also includes the disturbance of less than one acre of total land area that is part of a larger common plan of development or sale, if the larger common plan will ultimately disturb equal to or greater than one and less than five acres

"Stabilized" means the exposed ground surface has been covered by appropriate materials such as mulch, staked sod, riprap, erosion control blanket, or other material that prevents erosion from occurring. Grass seeding alone is not stabilization. Snow cover and frozen ground conditions are not considered stabilized.

"Steep Slopes" means slopes which are fifteen (15) percent or greater in grade.

"Stormwater" means stormwater runoff, snow melt runoff, and surface runoff and drainage.

"Stormwater Associated with Industrial Activity" means stormwater runoff, snow melt runoff, or surface runoff and drainage from industrial activities as defined in 40 CFR 122.26(b)(14).

"Stormwater Associated with Small Construction Activity" means the discharge of stormwater from:

(i) Construction activities including clearing, grading, and excavating that result in land disturbance of equal to or greater than once acre and less than five acres. Small construction activity also includes the disturbance of less than one acre of total land area that is part of a larger common plan of development or sale if the larger common plan will ultimately disturb equal to or greater than one and less than five acres. Small construction activity does not include routine maintenance that is performed to maintain the original line and grade, hydraulic capacity, or original purpose of the facility.

(ii) Any other construction activity designated by EPA or the department, based on the potential for contribution to a violation of a water quality standard or for significant contribution of pollutants to waters of the state.

"Temporarily Ceased" means clearing, grading, and excavation within any area of the site that will not include permanent structures, will not resume (i.e., the land will be idle) for a period of 14 or more calendar days, but such activities will resume in the future.

"Temporary Erosion Protection" means methods employed to prevent erosion. Examples of temporary cover include; mulch, straw, erosion control blanket, wood chips, tackifiers, and erosion netting.

"Upset" means an exceptional incident in which there is unintentional and temporary noncompliance with permit requirements because of factors beyond the reasonable control of the permittee. An upset does not include noncompliance to the extent caused by operational error, improperly designed erosion and sediment controls or site stabilization methods, inadequate erosion and sediment controls or site stabilization methods, lack of preventive maintenance, or careless or improper operation.

"Waters of the State" means any and all surface waters that are contained in or flow in or through the state of North Dakota as defined in NDCC 61-28-02. This definition includes all water courses, even if they are usually dry.

"You" means the owner, operator or permittee as appropriate.

## **Appendix 1 – Erosion and Sediment Control Requirements**

Requirements for designing, implementing and maintaining erosion and sediment controls.

### **A. Erosion and Sediment Control Practices**

1. Sites using temporary (or permanent) sediment basins must meet the following requirements:
  - a. Sediment basins shall be designed for a calculated volume of runoff from a 2-year, 24-hour storm per acre drained to the basin and provides not less than 1,800 cubic feet of sediment storage below the invert of the outlet pipe from each acre drained to the basin; or
  - b. Basins shall be sized to provide 3,600 cubic feet of sediment storage below the invert of the outlet pipe per acre drained to the basin if calculations are not performed.
  - c. Basin outlets must be designed to avoid short-circuiting and the discharge of floating debris. Basins must be designed with the ability to allow complete basin drawdown for maintenance activities. Basins must release the storage volume in at least 24 hours. Outlet structures must be designed to withdraw water from the surface, unless not practicable. If not practicable, rationale must be provided in the SWPPP. The basin must have a stabilized emergency overflow to prevent failure of pond integrity. Energy dissipation must be provided for the basin outlet.
2. Erosion, sediment, and stabilization practices shall be provided. Erosion, sediment and stabilization practices include such things as: silt fences, fiber logs, vegetative buffer strips, erosion control blankets, mulch, hydro-seeding combined with mulch or tackifiers, etc.
3. All exposed soil areas must be stabilized (see definitions). Stabilization must be initiated immediately where activities have been permanently or temporarily ceased on any portion of the site and will not resume for a period exceeding fourteen (14) calendar days. Stabilization must be completed as soon as practicable, but no later than fourteen (14) calendar days after the initiation of soil stabilization. Temporary stockpiles without significant silt, clay or organic components (e.g., clean aggregate stockpiles, demolition concrete stockpiles, sand stockpiles) are exempt from this requirement.
  - a. For slopes with a grade of 3:1 or greater, stabilization must be initiated immediately once activities have been completed or temporarily ceased. Stabilization must be completed as soon as practicable, but no later than seven (7) calendar days after the initiation of soil stabilization.
4. Temporary soil stockpiles must have effective sediment controls, and cannot be placed in surface waters, including stormwater conveyances such as curb and gutter systems, or conduits and ditches.
5. The normal wetted perimeter of any temporary or permanent drainage ditch that drains water from a construction site, or diverts water around a site, must be stabilized at least 200 linear feet from the property edge, or from the point of discharge to any surface water. Stabilization shall be completed prior to connection with a surface water. Any remaining portion of the temporary or permanent drainage ditch must be stabilized within fourteen (14) calendar days for portions which construction activities have temporarily or permanently ceased.
6. If stabilization requirements cannot be met due to circumstances beyond the control of the permittee, the permittee may comply with following:
  - a. If vegetative stabilization is to be used, immediately initiate, and within 14 calendars days complete, the installation of temporary non-vegetated stabilization; or
  - b. Complete all methods of initiating stabilization as soon as conditions or circumstances allow.

If any conditions in parts a or b above are encountered, the permittee must document the circumstances which prevented you from meeting the stabilization requirements in the SWPPP of this paragraph and provide a schedule in the SWPPP which will be followed in order to meet the stabilization requirements.

Permittees are responsible for implementing winter stabilization methods during frozen ground conditions if the site was not stabilized prior to the ground freezing.

7. Stream diversions or any temporary or permanent drainage ditch or trench, which will have continuous flow, shall be stabilized with appropriate controls prior to connection with any surface water. The entire area (channel and bank) of the stream diversion or temporary or permanent drainage ditch, or trench, must be appropriately stabilized to bankfull height.
8. While working in or around surface waters, sediment and erosion controls must be used above the anticipated level of the surface water. Floating silt curtain does not satisfy the down slope and side slope boundary requirements in Part II(C)(4)(b) of this permit, unless the construction activity is on or below the elevation of the surface water. The floating silt curtain must be placed as close to shore as possible. Sediment control must be installed where exposed soils drain to the surface water immediately after construction activity along the waterline has been completed.
9. Pipe and culvert outlets must be provided with energy dissipation within 24 hours of connection to a surface water.
10. Splash pads and/or downspout extensions must be provided for roof drains to prevent erosion from roof runoff.
11. All storm drain inlets in the immediate vicinity of the construction site must be protected by appropriate BMPs during construction until all disturbed areas and stockpiles with the potential to discharge to the inlet have been stabilized. This includes storm drain inlets which may be affected by sediment tracked onto paved surfaces by vehicles or equipment.
12. Inlet protection devices are a last line of control – erosion and sediment control practices must be used on-site. Inlet protection devices must conform to local ordinances or regulations. In general, inlet protection devices need to provide for adequate drainage to prevent excessive roadway flooding. Inlet protection may be removed for a particular inlet if a specific concern (i.e., street flooding/freezing, snow removal) has been identified and documented in the SWPPP. In this situation, additional erosion and sediment control practices, or stabilization methods must be used to supplement the loss of the inlet protection device to prevent sediment from entering the storm sewer system.
13. Vegetated buffers must have a minimum width of 1 foot for every 5 feet of disturbed area that drains to the buffer. The width of the buffer shall have a slope of 5 percent or less and the area draining to the buffer shall have a slope of 6 percent or less. Concentrated flows should be minimized throughout the buffer.

Buffers shall consist of dense grassy vegetation, 3 to 12 inches tall with uniform coverage over 90 percent of the buffer. Woody vegetation shall not be counted for the 90 percent coverage. No more than 10 percent of the overall buffer may be comprised of woody vegetation.

14. A 50 foot natural buffer or equivalent erosion and sediment controls must be provided when a project is within 50 feet of a surface water and stormwater flows to the surface water. If equivalent erosion and sediment controls are used, rationale for using equivalent controls must be provided in the SWPPP.

If working within 100 feet of a surface water listed as impaired for sediment, suspended solids or turbidity, a 100 foot natural buffer or equivalent sediment and erosion controls must be provided. If equivalent erosion and sediment controls are to be used, rationale for using equivalent controls must be provided in the SWPPP.

15. If the permittee(s) intend to use chemical treatment for sediment removal, they must be used in accordance with the manufacturer's specifications. Treatment chemicals must be selected appropriately for the anticipated soil particle size and characteristics of the stormwater (pH, turbidity, flow rate of stormwater flowing into the chemical treatment system, etc.). A description of the chemical treatment process must be included in the SWPPP.
- a. To ensure selection and management of chemicals minimize the potential for harmful effects in the discharge, the permittee shall provide a written request to the department for review and approval. Additional monitoring and reporting may be required as a condition for the approval to discharge.

A request to discharge chemically treated water shall include all of the following information and be provided sixty (60) days prior to use:

- i. Material Safety Data Sheet/Safety Data Sheet (MSDS/SDS);
  - ii. Proposed water additive discharge concentration;
  - iii. Discharge frequency (i.e., number of hours per day and number of days per year);
  - iv. Monitoring point for product discharge;
  - v. Type of removal treatment, if any, that the water additive receives prior to discharge;
  - vi. Product function (e.g., coagulant, flocculant, etc.);
  - vii. A 48-hour LC<sub>50</sub> or EC<sub>50</sub> for a North American freshwater planktonic crustacean (*Ceriodaphnia* sp., *Daphnia* sp., or *Simocephalus* sp.); and
  - viii. Results for a toxicity test for one other North American freshwater aquatic species (other than a planktonic crustacean).
- b. Discharges from the chemical treatment of stormwater must not cause a violation of the standards of quality for waters of the state (N.D.A.C. § 33-16-02.1). The discharge must meet the dewatering or basin draining requirements provided in Part II(C)(3)(g) of this permit.

16. Minimize the duration of exposed soils on steep slopes.

## **B. Maintenance Requirements for Erosion and Sediment Controls**

1. All erosion prevention and sediment control BMPs must be inspected to ensure integrity and effectiveness. All nonfunctional BMPs must be repaired, replaced, maintained or supplemented with functional BMPs. If a nonfunctioning BMP is supplemented, the nonfunctional BMP shall be removed. Corrective actions must be made prior to the next anticipated rainfall event or within 24 hours of discovery (whichever comes first), or as soon as field conditions allow access. Documentation must be provided in the maintenance records if field conditions do not allow access along with a plan of action for performing maintenance activities.

Permittee(s) must investigate and comply with the following inspection and maintenance requirements:

- a. All control devices similar to, and including, silt fence or fiber rolls must be repaired, replaced, maintained or supplemented when they become nonfunctional (torn from posts, visible tears, etc.). Collected sediment must be removed as it approaches 1/2 of the above ground capacity of the control device.
- b. Fiber rolls must be replaced when 1/2 of the original above ground height of the device when it was installed has been lost as a result of flattening or other damage.

- c. Sedimentation basins must be drained and the sediment removed when the depth of sediment collected in the basin reaches 1/2 the storage volume. Drainage and removal must be completed within 72 hours of discovery, or as soon as field conditions allow access. Documentation must be provided in the maintenance records if field conditions do not allow access along with a plan of action for performing maintenance activities.
  - d. Maintenance and cleaning of inlet protection devices must be performed when sediment accumulates, the filter becomes clogged, and/or performance is compromised.
2. Surface waters, including drainage ditches and conveyance systems, must be inspected for evidence of sediment deposited by erosion. Permittees must remove all deltas and sediment deposits in surface waters, drainage ways, catch basins, and other drainage systems. Areas where sediment removal results in exposed soil must be stabilized. Removal and stabilization must take place immediately, but no more than, seven (7) calendar days after the discovery unless precluded by legal, regulatory or physical access constraints. Permittees shall use all reasonable efforts to obtain access. If precluded, removal and stabilization shall take place immediately, but no more than, seven (7) calendar days after obtaining access. Permittees are responsible for contacting all local, regional, state, and federal authorities, and receiving any applicable permits prior to conducting any work.
  3. Vehicle tracking of sediment from the site must be minimized by BMPs. This may include having a designated egress with aggregate surfacing from the site or by designating off-site parking. Permittees are responsible for (or making the arrangements for) street sweeping and/or scraping if BMPs are not adequate to prevent sediment from being tracked onto the street from the site.

Construction site egress locations must be inspected for evidence of sediment being tracked offsite by vehicles or equipment onto paved surfaces. Accumulations of tracked and deposited sediment must be removed from all off-site paved surfaces by the end of the work day, shift or if applicable, within a shorter time specified by local authorities or the department.

4. If sediment escapes the construction site, off-site accumulations of sediment must be removed in a manner and at a frequency sufficient to minimize off-site impacts (e.g., fugitive sediment in streets could be washed into storm sewers by the next rain event and/or pose a safety hazard to users of public streets).
5. Vegetative buffers must be inspected for proper distribution of flows, sediment accumulation and signs of rill formation. If a buffer becomes silt covered, contains rills, or is otherwise rendered ineffective, other control measures shall be implemented. Eroded areas shall be repaired and stabilized within 24 hours of discovery, or as soon as conditions allow access. Documentation must be provided in the maintenance records if field conditions do not allow access along with a plan of action for performing maintenance activities.

### **C. Operational Controls**

1. Properly handle construction debris and waste materials.
  - a. Debris and waste must be handled appropriately until disposal. Litter and debris shall be collected and stored to reduce the potential for wind and water to carry the materials off-site or leachate discharging from a site. Collected material shall be taken to the appropriate facility for disposal or recycling.
  - b. Liquid or soluble materials including oil, fuel, paint and any other hazardous substances must be properly stored, to prevent spills, leaks or other discharges. Restricted access to storage areas must be provided to prevent vandalism. Storage and disposal of liquid or soluble material must be in compliance with applicable regulations.

2. Wash water containments must be cleaned out (solids and liquid) before 80 percent of storage capacity is attained.
3. Best management practices used in surface waters must be cleaned immediately upon removal from surface waters to prevent the transfer of aquatic nuisance species.