

June 29, 2018

VIA UPS

Mr. Darrell Nitschke
Executive Secretary
North Dakota Public Service Commission
600 E. Boulevard, Dept. 408
Bismarck, ND 58505-0480

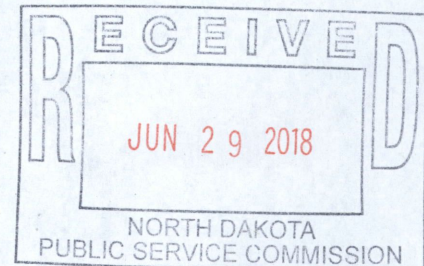

Re: **Harmony Solar ND, LLC's Application for a Certificate of Site Compatibility for the Harmony Solar Project in Cass County, North Dakota**
Case No. PU-18-___

Dear Mr. Nitschke:

Harmony Solar ND, LLC ("Harmony"), respectfully submits herewith an application for a Certificate of Site Compatibility for the Harmony Solar Project, to be located in Cass County, North Dakota. Harmony submits the application pursuant to North Dakota Century Code ("NDCC"), Chapter 49-22 and North Dakota Administrative Code ("NDAC"), Article 69-06.

In accordance with NDCC § 69-06-04-01(3), the original and ten (10) copies of the application and this letter are enclosed, as well as two CDs (one that contains an electronic copy of the application and this letter, and one that contains GIS information). A check in the amount of \$100,000.00 for the filing fee required pursuant to NDCC § 49-22-22 is also enclosed.

If you have any questions, please let me know.

Sincerely,

A handwritten signature in black ink that reads "Mollie M. Smith".

MOLLIE M. SMITH

MMS/ms
Enclosures

cc: Melissa Schmit
Brie Anderson
64299244.1

Attorneys & Advisors
main 612.492.7000
fax 612.492.7077
fredlaw.com

Fredrikson & Byron, P.A.
200 South Sixth Street, Suite 4000
Minneapolis, Minnesota
55402-1425

July 2018

North Dakota Public Service Commission

Application for a Certificate of Site Compatibility

Case No. PU-18-_____

Harmony Solar Project

Cass County, North Dakota

Submitted by:

Harmony Solar ND, LLC

7650 Edinborough Way

Suite 725

Edina, MN 55435



*Application to the North Dakota Public Service
Commission for a Certificate of Site
Compatibility*

**Harmony Solar Project
Cass County, North Dakota**

July 2, 2018

HARMONY SOLAR ND, LLC



7650 Edinborough Way

Suite 725

Edina, MN 55435

Applicant: Harmony Solar ND, LLC

Address: 7650 Edinborough Way, Suite 725
Edina, MN 55435

Authorized Representative: Melissa Schmit

Signature:

A handwritten signature in cursive script that reads "Melissa Schmit".

Phone: 952-988-9000

Fax: 952-988-9001

Email: melissa@geronimoenergy.com

TABLE OF CONTENTS

1.0	INTRODUCTION	8
1.1	Compliance with the Energy Conversion Transmission Facility Siting Act, North Dakota Century Code Chapter 49-22	8
1.2	Project Summary.....	11
1.2.1	Study Area	12
1.2.2	Project Area	12
1.2.3	Project Layout.....	12
1.2.4	Selection of Project Area	13
1.2.5	Project Area Solar Characteristics	13
1.2.6	Projected Output	13
1.3	Project Schedule.....	14
1.4	Expansion or Addition	14
1.5	Project Ownership.....	14
1.6	Project Cost.....	14
2.0	NEED FOR FACILITY	15
2.1	Need Analysis	15
2.2	Alternatives	16
2.3	Ten Year Plan	16
3.0	SITE SELECTION CRITERIA	17
3.1	Exclusion Areas	17
3.2	Avoidance Areas.....	19
3.3	Selection Criteria	20
3.4	Policy Criteria	24
3.5	Design and Construction Limitations	25
3.6	Economic Considerations	26
4.0	DESCRIPTION OF THE PROPOSED FACILITY	28
4.1	Project Components	28
4.1.1	Solar Facility.....	28
4.1.2	Associated Facilities	31
4.1.3	Temporary Facilities	32
4.2	Project Layout.....	32
4.3	Estimated Project Facility Impacts	33
5.0	ENGINEERING AND OPERATIONAL DESIGN ANALYSIS	34
5.1	Project Construction.....	34
5.1.1	Overview of Activities	34
5.1.2	Construction Activities	34
5.1.3	Construction Management	35
5.1.4	Commissioning	36
5.2	Project Operation and Maintenance.....	36
5.2.1	Supervisory Control and Data Acquisition System	37
5.2.2	Equipment Inspection	37

5.2.3	Performance Monitoring	37
5.2.4	Facility Maintenance	37
5.2.5	Maintenance Schedule	38
5.2.6	Operations and Maintenance Building.....	38
5.3	Decommissioning and Restoration	39
6.0	ENVIRONMENTAL ANALYSIS	41
6.1	Demographics	42
6.1.1	Demographic Impacts/Mitigation	43
6.2	Land Use, Ownership, and Management	44
6.2.1	Land Use Impacts/Mitigation	45
6.3	Public Services.....	46
6.3.1	Public Service Impacts/Mitigation.....	47
6.4	Human Health and Safety	48
6.4.1	Human Health and Safety Impacts/Mitigation	50
6.5	Sound	50
6.5.1	Sound Impacts/Mitigation.....	51
6.6	Visual	52
6.6.1	Visual Impacts/Mitigation	52
6.7	Cultural and Archaeological Resources.....	53
6.7.1	Cultural and Archaeological Impacts/Mitigation.....	54
6.8	Recreational Resources	54
6.8.1	Recreational Resources Impacts/Mitigation	54
6.9	Land-based Economics	54
6.9.1	Land-Based Economics Impacts/Mitigation.....	55
6.10	Soils.....	55
6.10.1	Soils Impacts/Mitigation.....	59
6.11	Geologic and Groundwater Resources.....	63
6.11.1	Geologic and Groundwater Impacts/Mitigation	64
6.12	Surface Water and Floodplain Resources	64
6.12.1	Surface Water and Floodplain Impacts/Mitigation.....	65
6.13	Wetlands	65
6.13.1	Wetlands Impacts/Mitigation.....	66
6.14	Vegetation	66
6.14.1	Vegetation Impacts/Mitigation	66
6.15	Wildlife	67
6.15.1	Wildlife Impacts/Mitigation.....	68
6.16	Rare and Unique Natural Resources	68
6.16.1	Rare and Unique Natural Resources Impacts/Mitigation	70
6.17	Summary of Impacts	71
7.0	IDENTIFICATION OF POTENTIAL PERMITS/APPROVALS	74
8.0	FACTORS CONSIDERED	76
8.1	Public Health and Welfare, Natural Resources, and the Environment	76
8.2	Minimizing Adverse Environmental Effects	76
8.3	Potential for Beneficial Uses of Waste Energy.....	76

8.4	Unavoidable Adverse Environmental Effects.....	76
8.5	Alternatives to the Proposed Site.....	76
8.6	Irreversible and Irretrievable Commitment of Natural Resources.....	77
8.7	Direct and Indirect Economic Impacts	77
8.8	Existing Development Plans of the State, Local Government and Private Entities at or in the Vicinity of the Site.....	77
8.9	Effect of Site on Cultural Resources.....	78
8.10	Effect of Site on Biological Resources	78
9.0	AGENCY COMMENTS	79
9.1	U.S. Department of Defense – Army Corps of Engineers, North Dakota Regulatory Office.....	79
9.2	US Fish & Wildlife Service	79
9.3	North Dakota Department of Health.....	79
9.4	North Dakota Department of Transportation.....	80
9.5	North Dakota Parks and Recreation Department.....	80
9.6	North Dakota State Water Commission.....	80
9.7	State Historical Society of North Dakota.....	80
9.8	Cass County	81
9.9	Harmony Township	81
9.10	Cass County Soil Conservation District	81
9.11	Rush River Water Resource District.....	81
10.0	QUALIFICATIONS OF CONTRIBUTORS TO SITING STUDY.....	82
11.0	REFERENCES	85

TABLES

Table 1-1:	Certificate Completion Checklist.....	9
Table 3-1:	Summary of Exclusion Areas.....	17
Table 3.2:	Summary of Avoidance Areas.....	19
Table 3.3:	Summary of Selection Criteria	20
Table 3.4:	Summary of Policy Criteria	24
Table 4-1:	Harmony Township Setback Requirements.....	32
Table 4-2:	Estimated Impacts from Project Facilities.....	33
Table 5-1:	Operations and Maintenance Tasks and Frequency.....	38
Table 6-1:	Demographic Information	43
Table 6-2:	Land Use Within the Study Area	44
Table 6-3:	Land Use Impacts.....	45
Table 6-4:	Decibel Levels of Common Noise Sources.....	51
Table 6-5:	Inverter and Tracker Noise Levels	52
Table 6-6:	Summary of Soils within Study Area.....	57
Table 6-7:	Farmland Classifications within Study Area.....	59
Table 6-8:	Soils Impact Summary	60
Table 6-9:	Farmland Classifications Impacted by the Project.....	62
Table 6-10:	NWI Wetlands within the Study Area.....	66

Table 6-11: Summary of Impacts	71
Table 7-1: Potential Permits/Approvals.....	74

FIGURES

Figure 1 – Project Location
Figure 2 – Project Facilities
Figure 3 – Exclusion Areas
Figure 4 – Avoidance Areas
Figure 5 – Land Use/Land Cover
Figure 6 – Existing Infrastructure
Figure 7 – Recreation
Figure 8 – Prime Farmland
Figure 9 – Water Features

APPENDICES

Appendix A – Project Site Plan
Appendix B – Ten Year Plan
Appendix C – Agency Outreach and Coordination
Appendix D – Glare Analysis
Appendix E – Cultural Resources Inventory Report
Appendix F – Wetland Delineation Report
Appendix G – Vegetation Management Plan
Appendix H – Harmony Policy Statement
Appendix I – Black and White Project Area Map

ACRONYMS AND ABBREVIATIONS

Acronym/Abbreviation	Definition
AC	alternating current
Applicant	Harmony Solar ND, LLC
Application	Harmony Solar ND, LLC's application to the North Dakota Public Service Commission for a Certificate of Site Compatibility
Area M	Area M Consulting
BCC	Birds of Conservation Concern
BCR	Bird Conservation Region
BGEPA	Bald and Golden Eagle Protection Act
BMP	best management practice
BNSF	Burlington Northern Santa Fe
Certificate	Certificate of Site Compatibility
Commission	North Dakota Public Service Commission
CUP	Conditional Use Permit
dB	decibels
dBA	A-weighted decibels
DC	direct current
DNI	direct normal irradiance
EMF	electromagnetic field
EPA	U.S. Environmental Protection Agency
ESA	Endangered Species Act
FIRM	National Flood Insurance Program
GAP	Gap Analysis Program
Geronimo	Geronimo Energy, LLC
GIS	Geographic Information System
Harmony	Harmony Solar ND, LLC
IPAC	Information for Planning and Consultation
JD	Jurisdictional Determination
kV	kilovolt
kWh/m ²	kilowatt hours per square meter
MBTA	Migratory Bird Treaty Act
MISO	Mid-Continent Independent System Operator
MW	megawatt
MWh	megawatt-hours

Acronym/Abbreviation	Definition
NDCC	North Dakota Century Code
NDAC	North Dakota Administrative Code
NLEB	northern long-eared bat
NDDH	North Dakota Department of Health
NDDOT	North Dakota Department of Transportation
NDGFD	North Dakota Game and Fish Department
NDPDES	North Dakota Pollutant Discharge Elimination System
NDSWC	North Dakota State Water Commission
NPL	National Priorities List
NRCS	Natural Resources Conservation Service
NRHP	National Register of Historic Places
NWI	National Wetlands Inventory
NWP	Nationwide Permit
O&M	Operations and Maintenance building
OSE	Office of the State Engineer
PPA	Power Purchase Agreement
Project	Harmony Solar Project
Project Area	1,662-acre Project boundary
PV	photovoltaic
REC	renewable energy credits
SCADA	Supervisory Control and Data Acquisition
SHPO	State Historic Preservation Office
Siting Act	North Dakota Energy Conversion and Transmission Facility Siting Act
SPCC Plan	Spill Prevention, Control, and Countermeasures Plan
SSURGO	Soil Survey Geographic Database
Study Area	Area within a 3-mile radius of the Project Area
SWPPP	Stormwater Pollution Prevention Plan
UDP	Unanticipated Discoveries Plan
U.S.	United States
USACE	U.S. Army Corps of Engineers
USDA	U.S. Department of Agriculture
USDOI	U.S. Department of Interior
USFWS	U.S. Fish & Wildlife Service
USGS	U.S. Geological Survey

Acronym/Abbreviation	Definition
UST	Underground Storage Tank
WPA	Waterfowl Production Area

1.0 INTRODUCTION

Harmony Solar ND, LLC (Harmony) respectfully submits this application (Application) to the North Dakota Public Service Commission (Commission) for a Certificate of Site Compatibility (Certificate) for the proposed Harmony Solar Project, a 200 megawatt (MW) solar energy conversion facility (Project). The Project Site Plan is included in Appendix A.

The Project will be in Harmony Township Sections 10, 11, and 16, Township 140 North, Range 51 West, Cass County, North Dakota (Figure 1). The Project will generate up to 200 MW, enough energy to provide electricity for approximately 41,000 homes annually and avoid the emission of approximately 277,000 metric tons of carbon annually.¹

Harmony is a wholly owned subsidiary of Geronimo Energy, LLC (Geronimo), a utility-scale renewable energy development company headquartered in Edina, Minnesota. Geronimo has developed multiple operating wind farms and solar projects throughout the United States. Over 1,800 MW of wind and solar projects developed by Geronimo are either under construction or operational. Geronimo has a multi-gigawatt development pipeline of wind and solar projects in various stages of development throughout the United States. Geronimo provides custom renewable energy development solutions for utilities, independent power purchasers and corporations looking to harness renewable energy for business growth. With deep roots in agriculture, Geronimo prides itself on developing wind farms that are farmer-friendly, community-driven, and beneficial for rural communities.

1.1 Compliance with the Energy Conversion Transmission Facility Siting Act, North Dakota Century Code Chapter 49-22

The North Dakota Energy Conversion and Transmission Facility Siting Act (Siting Act), North Dakota Century Code (NDCC), Chapter 49-22, requires a utility proposing to construct, own and operate an energy conversion facility in the state of North Dakota to obtain a Certificate from the Commission. The Siting Act specifies that the siting of an energy conversion facility is to be made “in an orderly manner compatible with environmental preservation and the efficient use of resources” (NDCC Section 49-22-02). An Application for a Certificate must meet certain criteria set forth in the Siting Act, as well as in the Commission’s Siting Rules (see Article 69-06 of the North Dakota Administrative Code (NDAC)).

In this Application, Harmony presents the information required by the Siting Act and the Commission’s Siting Rules. Harmony also discusses its consideration of the exclusion areas, avoidance areas, selection criteria, and policy criteria set forth in NDAC Section 69-06-08-01 (refer to Section 3.0). The Project’s anticipated design and technical information are also provided herein. Table 1-1 outlines the information required to fulfill the requirements of an application for a Certificate with references indicating where the information can be found in this Application.

¹ Based on EPA Greenhouse Gas Equivalencies Calculator and 1,700,000 kWh annual production PVSYST model.

Table 1-1: Certificate Completion Checklist

STATE AUTHORITY	DESCRIPTION	SECTION
Chapter 69-06-04	Certificate of Site Compatibility	
<i>Section 2</i>	<i>Contents</i>	
a. (1)	A description of the type of energy conversion facility proposed	1.0, 1.2 and 4.1
a. (2)	A description of the gross design capacity	1.2
a. (3)	A description of the net design capacity	1.2.5
a. (4)	A description of the estimated thermal efficiency of the energy conversion process and the assumptions upon which the estimated is based	NA
a. (5)	A description of the number of acres that the proposed facility will occupy, and	1.2
a. (6) a	A description of the anticipated time schedule for obtaining the certificate of site compatibility.	1.3
a. (6) b	A description of the anticipated time schedule for completing land acquisition	1.3
a. (6) c	A description of the anticipated time schedule for starting construction	1.3
a. (6) d	A description of the anticipated time schedule for completing construction	1.3
a. (6) e	A description of the anticipated time schedule for testing operations	1.3
a. (6) f	A description of the anticipated time schedule for commencing commercial production	1.3
a. (6) g	A description of the anticipated time schedule for beginning any expansions or additions	1.4
b.	Copies of any evaluative studies or assessments of the environmental impact of the proposed facility submitted to any federal, regional, state, or local agency	Appendices D, E, F
c.	An analysis of the need for the proposed facility based on present and projected demand for the product or products to be produced by the proposed facility, including the most recent system studies supporting the analysis of the need	2.1
d.	A description of any feasible alternative methods of serving the need.	2.2
e.	A study area that includes the proposed facility site, of sufficient size to enable the Commission to evaluate the factors addressed in North Dakota Century Code section 49-22-09.	1.2 and 6.0
f.	A discussion of the utility's policies and commitments to limit the environmental impact of its facilities, including copies of board resolutions and management directives.	Appendix H
g.	A map identifying the criteria that provides the basis for the specific location of the proposed facility within the study area.	Figures 2, 3, and 4

Table 1-1: Certificate Completion Checklist

STATE AUTHORITY	DESCRIPTION	SECTION
h.	A discussion of the criteria evaluated within the study area, including exclusion areas, avoidance areas, selection criteria, policy criteria, design and construction limitations, and economic considerations.	3.0-3.6
i.	A discussion of the mitigative measures that the applicant will take to minimize adverse impacts which results from the location, construction, and operation of the proposed facility.	6.0-6.17
j.	The qualifications of each person involved in the facility site location study.	10.0
k.	A map of the study area showing the location of the proposed facility and the criteria evaluated.	Figures 1-9
l.	An 8 ½-inch by 11-inch black and white map suitable for newspaper publication depicting the site area.	Appendix I
m.	A discussion of present and future natural resource development in the area	6.11
n.	Map and GIS requirements. The applicant shall provide information that is complete, current, presented clearly and concisely, and supported by appropriate references to technical and other written material available to the Commission.	Figures 1-9
NDCC Section 49-22-08	Description of Application Requirements	
<i>Section 1</i>	<i>An application for a certificate shall be in such form as the commission may prescribe, containing the following information:</i>	
a.	A description of the size and type of facility.	1.0, 1.2 and 4.0
b.	A summary of any studies which have been made of the environmental impact of the facility.	1.2.3 and 6.0-6.17
c.	A statement explaining the need for the facility.	2.1
d.	An identification of the location of the preferred site for any energy conversion facility.	1.2.1 and Figures 1-9
e.	An identification of the location of the preferred corridor for any transmission facility.	NA
f.	A description of the merits and detriments of any location identified and a comprehensive analysis with supporting data showing the reasons why the preferred location is best suited for the facility	1.1, 1.2, 2.0-3.6 and 6.0-6.17
g.	A description of mitigative measures that will be taken to minimize all foreseen adverse impacts resulting from the location, construction, and operation of the proposed facility.	6.0-6.17
h.	An evaluation of the proposed site or corridor with regard to the applicable considerations set out in section 49-22-09 and the criteria established pursuant to section 49-22-05.1.	3.0-3.6, 6.0-6.17, and 8.0-8.10
i.	Such other information as the applicant may consider relevant or the commission may require.	Complete Application including Figures and Appendices

Table 1-1: Certificate Completion Checklist

STATE AUTHORITY	DESCRIPTION	SECTION
NDCC 49-22-09	Factors to be considered in evaluating applications and the designation of sites, corridors, and routes.	
1.	Available research and investigations relating to the effects of the location, construction, and operation of the proposed facility on public health and welfare, natural resources, and the environment.	8.1
2.	The effects of new energy conversion and transmission technologies and systems designed to minimize adverse environmental effects.	8.2
3.	The potential for beneficial uses of waste energy from a proposed energy conversion facility.	8.3
4.	Adverse direct and indirect environmental effects which cannot be avoided should the proposed site or route be designated.	8.4
5.	Alternatives to the proposed site, corridor, or route which are developed during the hearing process and which minimize adverse effects.	8.5
6.	Irreversible and irretrievable commitments of natural resources should the proposed site, corridor, or route be designated.	8.6
7.	The direct and indirect economic impacts of the proposed facility.	8.7
8.	Existing plans of the state, local government, and private entities for other developments at or in the vicinity of the proposed site, corridor, or route.	8.8
9.	The effect of the proposed site or route on existing scenic areas, historic sites and structures, and paleontological or archaeological sites.	8.9
10.	The effect of the proposed site or route on areas which are unique because of biological wealth or because they are habitats for rare and endangered species.	8.10
11.	Problems raised by federal agencies, other state agencies, and local entities.	9.0-9.11

1.2 Project Summary

The Project will be located in Sections 10, 11, and 16, Township 140 North, Range 51 West, Cass County, North Dakota (Figure 1). The 1,662-acre project area (Project Area) lies in the Agricultural District of Harmony Township. The planned Project design will be an up to 200 MW solar energy generating system. It is proposed to utilize typical photovoltaic panels, inverters and a linear axis tracking system. The estimated construction start date could be as early as spring of 2019 with completion of construction by the end of 2020.

Harmony plans to construct a Project substation and interconnect to the existing Bison Substation located in Township 140, Range 51, Section 11 via a 345 kV Gen-Tie transmission line that will be less than a mile in length (up to 0.86 miles or 4,540 feet). Pursuant to 49-22-03-6(b), the

Project's transmission line is not defined as an "electric transmission facility" because it is less than one mile in length. As such, the proposed line falls outside of the Commission's siting jurisdiction and is not described further in this Application. The transmission line has been permitted through Harmony Township and is shown on Figure 2 for reference.

Note that of the 1,662 acres within the Project Area, the Project facility, or the area that will host the solar facilities, will be approximately 1,360.9 acres (see Figure 2). There are 300 acres within the Project Area and beyond the fence line of the Project facility, that would continue to be used for crop production, pending landowner preferences.

1.2.1 Study Area

Additionally, Harmony reviewed a study area consisting of the area within a three-mile radius of the Project Area (Study Area) for its environmental analysis (refer to Section 6.0). The environmental analysis of the Study Area is intended to provide a description of the natural and human environment in which the Project will be constructed.

1.2.2 Project Area

The Project Area is composed of private land parcels in Sections 10, 11, and 16 of Harmony Township subject to easement agreements between Harmony and Cass County landowners. Harmony selected the specific Project Area based on significant landowner interest, transmission and interconnection suitability, optimal solar resource, and minimal impact on environmental resources (see Section 2.2).

1.2.3 Project Layout

In this Application, Harmony is providing a preliminary Project layout (Figure 2 and Appendix A), subject to final micrositing within the Project Area. The Project's facilities will include solar modules (panels) and racking, inverters, security fencing, laydown areas, Project substation, an Operation and Maintenance building (O&M), on-site underground electrical collection and communication lines, and at least two weather stations (up to 20 feet tall). With the exception of 1,855 feet of underground electrical collection lines connecting the solar arrays in Section 16 to Sections 10 and 11, all Project facilities are located within a security fence (see Figure 2). The Project facilities are described in more detail in Section 4.0.

The Project footprint is approximately 1,362.0 acres (includes 1.1 acres of temporary impact beyond the fence line of the Project facility; however, the entire Project Area has been surveyed for natural and cultural resources. In addition to presenting a description of the Study Area and Project Area in Section 6.0, Harmony also presents a discussion of potential impacts and mitigation measures related to construction and operation of the Project facility.

Harmony has provided a site plan of existing conditions and a draft site plan of proposed conditions for the solar energy generating system in Appendix A. This proposed site plan denotes the general footprint and layout of the Project including proposed locations of facilities. These are also displayed on Figure 2. The Project's layout optimizes electrical generation and efficiency, while avoiding and minimizing environmental and economic impacts, and maintaining compliance with

all other local, state, and federal regulatory standards. Final site plans will be provided to the Commission and Harmony Township prior to construction.

1.2.4 Selection of Project Area

The Project originated through Geronimo's existing relationships with members of the local community, leading to seven landowners participating in the Project. After analyzing a broader area for solar resource, geographic characteristics, easement availability, landowner interest, environmental resources, transmission availability and economic potential, Harmony, in coordination with local landowners, selected the Project Area identified in this Application. Harmony selected the specific Project Area because of its potential as a solar facility site, available land, proximity to viable interconnection options, and interested local landowners. Further, the Project is compatible with the existing land use and environmental features within the Project Area. Site-specific studies have been done for both cultural resources and wetlands and waterbodies. Results of these studies have informed the design of the Project. These studies are discussed in more detail in Sections 6.7, 6.12, and 6.13, respectively.

1.2.5 Project Area Solar Characteristics

Harmony has collected approximately 18 months of on-site data from one meteorological tower, indicating a site-specific annual direct normal irradiance (DNI) of 1536 kWh/m² and has determined the Project site will be an economically viable location for solar energy generation. A key measure of the intensity of sunlight in an area is the DNI, which is the energy density perpendicular to the plane of the solar array. According to the Clean Power Research Solar Anywhere dataset, annual DNI in Fargo, ND is 1555 kilowatt hours per square meter (kWh/m²), which is approximately equal to that observed in Louisville, Kentucky located nearly 550 miles more south than Fargo. Despite the lower latitude, the irradiance between the two cities is similar due to humid and hazy conditions in the southeast U.S. which scatter and absorb more of the incoming irradiance than at higher latitudes in more continental climates.

1.2.6 Projected Output

The Project will have a nameplate (gross) generating capacity of up to 200 MW, with projected average annual output of up to 360,756 megawatt hours (MWh). This projected average annual output assumes a net capacity factor between 18 and 22 percent. The net capacity delivered to the electrical transmission system on an annual basis will be approximately 357,149 MWh. A typical capacity factor for solar energy projects in the Great Plains region is approximately 15 to 25 percent. Harmony recognizes that actual Project output will be determined by the solar resource, final design, and equipment selection and will vary on an inter-annual basis.

1.3 Project Schedule

The anticipated schedule for land acquisition, Certificate receipt, construction, testing, and commercial operation is outlined below:

- **Land acquisition:** Complete.
- **Certificate of Site Compatibility:** Harmony anticipates the Certificate will be issued in the fourth quarter of 2018.
- **Conditional Use Permit:** Harmony filed an application for a Conditional Use Permit (CUP) with Harmony Township in June 2017 and a CUP was issued on August 27, 2017 for a duration of three years.
- **Other Permits:** Harmony will acquire all other permits necessary for construction of the Project prior to conducting the work for which the permit is required. Refer to Table 7-1 Potential Permits/Approvals.
- **Construction:** Harmony anticipates that construction will begin as early as spring of 2019 and will be completed by the end of 2020.
- **Commercial Testing:** Testing for the Project is expected to begin in fourth quarter 2020, following the completion of construction.
- **Commercial Operations:** Commercial operation for the Project is scheduled to begin as early as the fourth quarter 2020, following the completion of construction and testing.

1.4 Expansion or Addition

Harmony does not anticipate expanding the proposed Project. However, Geronimo is analyzing the potential for a second solar project, which would be owned by a different subsidiary and permitted separately.

1.5 Project Ownership

Harmony has a lease option with the landowners for the Project site. The Project will be constructed, owned, and operated by Harmony, a wholly owned subsidiary of Geronimo. Geronimo is a privately held renewable energy developer with headquarters in Edina, Minnesota with multiple regional offices including an office in Fargo, North Dakota.

1.6 Project Cost

The total installed capital costs for the Project are estimated to be approximately \$250 million, with project cost depending on variables including, but not limited to, construction costs, taxes, tariffs, and panel selection, along with associated electrical and communication systems, and access roads.

2.0 NEED FOR FACILITY

2.1 Need Analysis

Harmony is proposing to construct this facility to sell energy, capacity and renewable energy credits (RECs), either bundled or unbundled, to one or more electric utilities and/or commercial customers. Harmony is actively marketing the Project to a number of potential off-takers and may sell the power in the form of a Power Purchase Agreement (PPA), or the Project could be owned directly by a utility.

As an independent power producer, Harmony is not limited to the needs of one region and is able to bid into multiple wholesale markets across the region. For example, over the past year Harmony was eligible to bid into 8 utility and 14 corporate/industrial power supply proposal requests in the region. Utilities and other customers seeking to diversify and build their energy generation portfolios are attracted to solar energy projects because of long-term, fixed, competitive pricing, high capacity value, environmental benefits and existing and potential renewable energy policies.

Renewable Energy Policies

In March 2007, North Dakota enacted legislation (H.B. 1506) establishing an *objective* that 10 percent of all retail electricity sold in the state be obtained from renewable energy and recycled energy by 2015. The objective must be measured by qualifying megawatt-hours (MWh) delivered at retail, or by credits purchased and retired to offset non-qualifying retail sales. This objective is voluntary; there is no penalty or sanction for a retail provider of electricity that fails to meet the objective. Municipal utilities and electric cooperatives that receive wholesale electricity through a municipal power agency or generation and transmission cooperative may aggregate their renewable and recycled energy objective resources to meet the objective.

As of reports filed with the Commission in 2017, all filing utilities indicated that they presently meet their 10% objective for renewables. However, also in 2007, the North Dakota Legislature enacted a statutory provision adopting the national "25x25" initiative, which establishes a goal of having not less than twenty-five percent of the total energy consumed within the United States come from renewable resources by January 1, 2025 (see NDCC. § 17-01-01). Additional renewable resources will be needed to meet the 25x25 initiative.

Moreover, North Dakota is proximate to other jurisdictions that also have renewable policies. Minnesota, in particular, has a standard that requires Xcel Energy to obtain 30% of its energy from renewables by 2020, and all other utilities to obtain 25% of their energy from renewables by 2025. In addition, Minnesota investor-owned utilities are required to obtain 1.5% of their energy from solar by 2020. North Dakota's available land and good insolation, along with newly constructed transmission lines, create an ideal environment for solar energy projects to meet Minnesota's renewable and solar standard.

Economic Energy and Capacity

With improving technology and falling costs, utilities are beginning to include solar projects in their resource plans as long-term economic energy and capacity resources. In North Dakota, peak

solar generation has a high correlation with the Mid-Continent Independent System Operator's (MISO) coincident peak, which determines the reserve margins MISO utilities must maintain for reliability and reserve sharing purposes. Recent solar pricing has shown that the costs of energy and capacity of utility scale solar are on par with building a simple cycle CT to provide peaking power (Lazard's Levelized Cost of Energy Analysis 10.0, 2016).

For example, in its 2015 Resource Plan filing, the Commission approved Xcel Energy's proposed purchase of up to 1000 MW of solar by 2021, even though it has already exceeded the Minnesota's solar energy standard.

Commercial and Industrial Demand

In addition to traditional utility demand for solar energy, a growing number of corporations are turning to renewable energy to save money on energy and meet sustainability goals. Corporate customers either purchase renewable energy directly or obtain renewable benefits and cost savings through financially settled contracts, sometimes called virtual PPAs. Corporations such as Apple, Google and Facebook along with many others, have recently set goals to obtain 100 percent of their energy from renewables. In 2016, approximately 1600 MW of renewable energy was purchased by commercial, industrial, and institutional customers, and the number of requests for proposals doubled in 2017 (Renewable Choice Energy 2017). In a recent survey, 84% percent of corporations stated that they planned to purchase renewable energy in the next 2 years.

2.2 Alternatives

Potential alternatives to solar energy include electricity generation using coal, natural gas, wind energy, hydropower or biomass. Potential purchasers of the Project's output will likely consider these other forms of energy, especially renewable energy such as wind, biomass and hydropower, to meet their demand. Which renewable is preferred depends on many factors, including the nature of the demand. While wind energy is currently considered one of the most cost-effective means of energy generation, solar energy provides a higher capacity value and generates most of its energy during peak hours, which can make it a valuable resource for many off-takers.

2.3 Ten Year Plan

In accordance with NDCC § 49-22-04 and NDAC Chapter 69-06-02, Harmony filed a Ten Year Plan on June 27, 2018. Harmony's Ten Year Plan is consistent with this Application for a Certificate and is included in Appendix B.

3.0 SITE SELECTION CRITERIA

Harmony selected the Project Area based on landowner support, as well as an assessment of area technical and environmental characteristics, and energy demand in the region. Site selection was also based upon the criteria described in NDAC Chapter 69-06-08. These criteria are discussed further below.

3.1 Exclusion Areas²

The geographical areas identified in Section 69-06-08-01(1) of the NDAC “must be excluded in the consideration of a site for an energy conversion facility.” The applicability of these exclusion areas is summarized below in Table 3-1. Exclusion areas in the Study and Project Areas are depicted on Figure 3.

Table 3-1: Summary of Exclusion Areas

GENERAL EXCLUSION AREA	PRESENT WITHIN PROJECT AREA?	DESCRIPTION	SECTION ADDRESSED
Designated or registered national: parks; memorial parks; historic sites and landmarks; natural landmarks; historic districts; monuments; wilderness areas; wildlife areas; wild, scenic, or recreational rivers; wildlife refuges; and grasslands.	None	NA	6.2, 6.6, 6.7,6.8,6.12
Designated or registered state: parks; forests; forest management lands; historic sites; monuments; historical markers; archaeological sites; grasslands; wild, scenic, or recreational rivers; game refuges; game management areas; management areas; and nature preserves.	None	NA	6.2, 6.6, 6.7,6.8,6.12
County parks and recreational areas; municipal parks; parks owned or administered by other governmental subdivisions; hardwood draws; and enrolled woodlands.	None	NA	6.8, 6.9

² As defined in NDAC 69-06-01-01, exclusion areas are “criteria that remove areas from consideration for energy conversion facility sites and transmission facility routes.” Exclusion areas are composed of these limiting criteria.

Table 3-1: Summary of Exclusion Areas

GENERAL EXCLUSION AREA	PRESENT WITHIN PROJECT AREA?	DESCRIPTION	SECTION ADDRESSED
Prime farmland and unique farmland, as defined by the land inventory and monitoring division of the soil conservation service, U.S. Department of Agriculture (USDA), in 7 C.F.R. Part 657; provided, however, that if the Commission finds that the prime farmland and unique farmland that will be removed from use for the life of the facility is of such small acreage as to be of negligible impact on agricultural productions, this exclusion does not apply.	Present	Land within the Project Area is considered prime farmland or prime farmland if drained. The Project will directly impact 41.4 acres of prime farmland or prime farmland if drained that are also classified by USGS GAP as agricultural, and will result in a total of 1,353.5 acres of agricultural land designated as prime farmland or prime farmland if drained being converted to a different use during the life of the Project. This equates to approximately 3.7 percent of the prime farmland or prime farmland if drained in the Study Area. Conversion to grassland will not constitute a loss of prime farmland as the physical and chemical characteristics that make the land suitable for classification as prime farmland will remain the same. Therefore, Harmony requests that the Commission determine that the prime farmland exclusion does not apply to the Project.	6.10
Irrigated land.	None	NA	--
Areas critical to the life stages of threatened or endangered animal or plant species.	None	NA	6.16
Areas where animal or plant species that are unique or rare to this state would be irreversibly damaged.	None	NA	6.16
Areas within 1,200 feet of the geographic center of an intercontinental ballistic missile (ICBM) launch or launch control facility.	None	NA	--

3.2 Avoidance Areas³

Per Section 69-06-08-01(3) of the NDAC, “The following geographical areas may not be approved as a site for an energy conversion facility unless the applicant shows that under the circumstances there is no reasonable alternative. In determining whether an avoidance area should be designated for a facility the commission may consider, among other things, the proposed management of adverse impacts; the orderly siting of facilities; system reliability and integrity; the efficient use of resources; and alternative sites. Economic considerations alone will not justify approval of these areas. A buffer zone of a reasonable width to protect the integrity of the area must be included. Natural screening may be considered in determining the width of the buffer zone.” See Table 3-2 for a discussion of the criteria outlined in Section 69-06-08-01(2). Avoidance areas in the Study and Project Areas are depicted on Figure 4.

Table 3-2: Summary of Avoidance Areas

AVOIDANCE AREA	PRESENT WITHIN PROJECT AREA?	DESCRIPTION	SECTION ADDRESSED
Historical resources which are not designated as exclusion areas.	None	NA	6.7
Areas within the city limits of a city or the boundaries of a military installation.	None	NA	6.1, 6.2
Areas within known floodplains as defined by the geographical boundaries of the hundred-year flood.	None	NA	6.12
Areas that are geologically unstable.	None	NA	6.11
Woodlands and wetlands.	None	NA	6.9, 6.13
Areas of recreational significance which are not designated as exclusion areas.	None	NA	6.8

³ As defined in NDAC 69-06-01-01, avoidance criteria are “criteria that remove areas from consideration for energy conversion facility sites and transmission facility routes unless it is shown that under the circumstances there are no reasonable alternatives.” Avoidance areas are composed of these limiting criteria.

3.3 Selection Criteria⁴

Per Section 69-06-08-01(5) of the NDAC, “[a] site may be approved in an area only when it is demonstrated to the Commission by the applicant that any significant adverse effects resulting from the location, construction, and operation of the facility in that area, as they relate to the following, will be at an acceptable minimum, or that those effects will be managed and maintained at an acceptable minimum.” Table 3-3 provides a summary of the selection criteria.

Table 3-3: Summary of Selection Criteria

SELECTION CRITERIA	POTENTIAL ADVERSE EFFECTS FROM PROJECT	SECTION ADDRESSED
<i>The impact upon agriculture:</i>		
(1) Agricultural production.	<p>Direct impacts and conversion of land currently used for agricultural production will not result in a significant impact to agricultural production in the Study Area. As noted in Section 6.2.1, direct impacts and conversion of 1,353.5 acres of agricultural land to developed and grassland within the fenced area of the solar facility would reduce the amount of agricultural land in the Study Area by 3.8 percent. Agricultural production would be allowed to continue in the surrounding areas during construction and operation of the Project.</p> <p>Any revenue lost by removing land from agricultural production will be offset by solar energy production and the associated Land Lease and Solar Easement payments to the associated landowners. Additionally, the Project’s seed mixes across approximately 1,319.2 acres will promote biodiversity, create stable habitat, attract pollinators, and provide the potential for agricultural production in the form of: bee hives on the site and/or providing crops for sheep, if the vegetation maintenance strategy will be grazing.</p>	6.9, 6.10, and 6.17
(2) Family farms and ranches.	<p>Conversion of land within the Project footprint currently used for agricultural production to developed and grassland will result in some economic losses. However, the revenue lost from removing land from agricultural production will be offset by Land Lease and Solar Easement payments to the associated landowners.</p>	6.9

⁴ As defined in NDAC 69-06-0101, selection criteria is defined as “criteria that guide and govern the selection of energy conversion facility sites and transmission facility corridors and routes in order to minimize adverse human and environmental impact after the exclusion and avoidance criteria have been applied.”

Table 3-3: Summary of Selection Criteria

SELECTION CRITERIA	POTENTIAL ADVERSE EFFECTS FROM PROJECT	SECTION ADDRESSED
(3) Land which the owner demonstrates has soil, topography, drainage, and an available water supply that cause the land to be economically suitable for irrigation.	Landowners have not expressed concerns about or identified irrigation systems on their properties, and no known irrigation systems are present within the Project Area.	NA
(4) Surface drainage patterns and ground water flow patterns.	No adverse impacts to surface drainage patterns and ground water flow patterns are anticipated.	6.12
(5) The agricultural quality of the cropland.	No adverse impact to the agricultural quality of cropland is anticipated. Harmony will compensate landowners for the placement of Project facilities on their property and for any crop damages that occur during construction of the Project.	6.2, 6.10
<i>The impact upon the availability and adequacy of:</i>		
(1) Law enforcement.	No adverse impacts to the availability and adequacy of law enforcement are anticipated.	6.3
(2) School systems and education programs.	No adverse impacts to the availability and adequacy of school systems and education programs are anticipated.	6.3
(3) Governmental services and facilities.	No adverse impacts to the availability and adequacy of governmental services and facilities are anticipated.	6.3
(4) General and mental health care facilities.	No adverse impacts to the availability and adequacy of mental health care facilities are anticipated.	6.3
(5) Recreational programs and facilities.	No adverse impacts to the availability and adequacy of recreational programs and facilities are anticipated.	6.8
(6) Transportation facilities and networks.	There will be a temporary increase in traffic during construction activities. No impacts to traffic are anticipated during operation of the facility.	6.3
(7) Retail service facilities.	No adverse impacts to the availability and adequacy of retail service facilities are anticipated.	6.3
(8) Utility services.	No adverse impacts to the availability and adequacy of utility services are anticipated.	6.3
<i>The impact upon:</i>		
(1) Local institutions.	No adverse impacts on local institutions are anticipated.	6.3

Table 3-3: Summary of Selection Criteria

SELECTION CRITERIA	POTENTIAL ADVERSE EFFECTS FROM PROJECT	SECTION ADDRESSED
(2) Noise-sensitive land uses.	Noise-sensitive land uses in the Project Area are limited to residences near the solar facility. The nearest residence to the Project is approximately 1,085 feet away. This residence is owned by a Project participant. Construction of the Project will result in temporary increases in noise in the vicinity of the Project Area. During construction, Harmony will limit construction activities to daylight hours. Harmony conducted a noise modeling analysis to assess the potential for increases in noise during operation of the facility. The analysis concluded that noise emitted during operation of the solar facility is not expected to be discernible from background noise levels at homes in the vicinity. No adverse impacts on noise-sensitive land uses are anticipated during construction or operation of the Project.	6.5
(3) Light-sensitive land uses	Construction activities will occur during daylight hours, limiting impacts of lighting. Operation of the Project will require down lit security lighting at the entrance of the Project and there may be down lit, switch controlled lights at each inverter for repair purposes. Impacts to light-sensitive land uses are not anticipated given the rural project location coupled with minimal required lighting for operations.	6.6
(3) Rural residences and businesses.	No adverse impacts on rural residences and businesses are anticipated.	6.2, 6.5, 6.6
(4) Aquifers.	No aquifers are present within the Project Area; therefore, no impacts on aquifers are anticipated.	6.11
(5) Human health and safety.	No adverse impacts on human health and safety are anticipated.	6.4
(6) Animal health and safety.	No adverse impacts on animal health and safety are anticipated.	6.15, 6.16
(7) Plant life.	The Project Area is comprised of agricultural and developed land; existing vegetation in the Project Area is limited to row crops. The Project will impact 1,353.5 acres of agricultural land, 41.4 acres of which will be converted to impervious surfaces. The other 1,312.1 acres of agricultural land will be revegetated with a seed mix developed with prairie specialists (and approved by the NRCS Cass County Soil Conservation District) to design a mix that will achieve Harmony's goals for operating the solar facility, promote pollinator habitat, establish stable ground cover successfully, reduce erosion, reduce runoff, and improve infiltration. For these reasons, the overall impact on plant life in the Project Area will be positive.	6.14

Table 3-3: Summary of Selection Criteria

SELECTION CRITERIA	POTENTIAL ADVERSE EFFECTS FROM PROJECT	SECTION ADDRESSED
(8) Temporary and permanent housing.	During construction of the Project, temporary housing such as motels, hotels, and rental housing may be utilized by construction personnel. Harmony anticipates that sufficient temporary housing will be available within Cass County, and within the Fargo-Moorhead metropolitan area, to accommodate construction personnel. Up to 12 full time personnel will be required during operation of the facility and sufficient long-term housing exists in Cass County and the nearby Fargo-Moorhead metropolitan area. No adverse impacts to temporary or permanent housing are anticipated.	6.1
(9) Temporary and permanent skilled and unskilled labor.	Skilled and unskilled labor is expected to be available in Cass County or North Dakota to serve the Project's basic infrastructure and site development needs. Specialized labor will be required for certain aspects of the Project. It may be necessary to import specialized labor from other areas of North Dakota or neighboring states because the relatively short construction duration often precludes special training of local or regional labor. Skilled labor would receive short-term economic benefits during construction. No adverse impacts are anticipated.	6.1
<i>Cumulative impact:</i>		
The cumulative effects of the location of the facility in relation to existing and planned facilities and other industrial development.	Geronimo Energy is developing a two phased wind Farm in Cass County (Prosperity Wind Farm 1 and 2) located approximately 12 miles west of Harmony. This new development coupled with existing wind facilities in the area are not anticipated to have adverse cumulative effects, given the distance from the wind facilities and the fact that the solar development is low profile solar development and has other characteristics that differ from wind facilities. Additionally, Harmony is located approximately 7 miles from West Fargo, approximately 3 miles from Mapleton, and approximately 3 miles from Casselton. At these distances, the Project will not interfere with any potential planned expansion of the surrounding municipal boundaries. Harmony believes there is additional solar opportunity in the area and a second phase of Harmony is under development. However, adverse cumulative effects are not anticipated as solar is low profile, does not create odors and is virtually noiseless. Even with the planned development in the area, there is an abundant amount of property in the Project vicinity and in Cass County to accommodate other possible industrial development.	NA

3.4 Policy Criteria⁵

In accordance with Section 69-06-08-01(6) of the NDAC, “The Commission may give preference to an applicant that will maximize benefits that result from the adoption of the following policies and practices, and in a proper case may require the adoption of such policies and practices. The commission may also give preference to an applicant that will maximize interstate benefits.” These policy criteria are addressed below in Table 3-4.

Table 3-4: Summary of Policy Criteria

POLICY CRITERIA	APPLICANT’S POLICIES AND PRACTICES	SECTION ADDRESSED
Recycling of the conversion byproducts and effluents	The selected construction contractor typically develops a Waste and Recycling Management Plan. Additionally, cardboard the panels are delivered in and other reusable construction materials will be recycled.	NA
Energy conservation through location, process, and design	The proposed Project has been designed to maximize energy conversion where available.	1.2 and 3.5
Training and utilization of available labor in this state for the general and specialized skills required	Harmony will create new local job opportunities for various trade professionals and will use skilled and trained labor from North Dakota, as possible.	6.1
Use of a primary energy source or raw material located within the state	The energy generated will come from available solar resources of the state. In addition, gravel will likely be obtained from a local source for access roads and inverter pad construction.	1.2.4
Not relocating residents	No relocation of residents will occur.	6.2
The dedication of an area adjacent to the facility to land uses such as recreation, agriculture, or wildlife management	The Project will not interfere with adjacent land uses. Additionally, the site will utilize a pollinator friendly seed mix, thereby potentially benefitting and increasing the overall populations of wildlife species in the area, including small mammals, reptiles, and pollinator insects. Further, land adjacent to the Project Area is privately owned and not under Harmony’s control. For these reasons, Harmony does not plan to dedicate an area of land adjacent to the Project to the specified land uses.	6.2 and 6.14
Economies of construction and operation	As a 200 MW solar project, Harmony will benefit from economies of scale related to Project construction and operation. Solar energy projects have one-time costs that remain relatively stable despite the scale of the project. Therefore, a larger project will have cost advantages in comparison to a smaller project because the fixed costs are spread out over more units of output. Some examples of solar project costs that remain similar despite the project size: an on-site office space and substation procurement and construction.	3.6 and 6.1

⁵ As defined in NDAC 69-06-01-01, policy criteria are ‘criteria’ that guide and govern the selection of energy conversion facility sites and transmission facility corridors and routes in order to maximize benefits during the construction and operation of a facility.

Table 3-4: Summary of Policy Criteria

POLICY CRITERIA	APPLICANT'S POLICIES AND PRACTICES	SECTION ADDRESSED
Secondary uses of appropriate associated facilities for recreation and the enhancement of wildlife	The Project will not interfere with adjacent land uses. Additionally, the site will utilize a pollinator friendly seed mix, thereby potentially benefitting and increasing the overall populations of wildlife species in the area, including small mammals, reptiles, and pollinator insects.	6.14
Use of citizen coordinating committees	Harmony has coordinated and will continue to coordinate with landowners and local businesses and groups located within and near the Project Area. Therefore, a citizen coordinating committee is not needed.	9.0
A commitment of a portion of the energy produced for use in this State	Electricity generated by Harmony will enter the North Dakota grid and will follow the path of least resistance in terms of where it is used. If the power is purchased by an out of state buyer the electricity will remain near the Project and will continue to contribute towards North Dakota's renewable, recycled, and conserved energy production.	
Labor relations	No impact to labor relations are anticipated.	NA
The coordination of facilities	Existing facilities were considered in the location of the Project and its associated facilities.	3.5, 6.3, 6.4
Monitoring of impacts	Harmony Solar will monitor construction activities and use Best Management Practices (BMPs) throughout Project construction. During Project operation and restoration, Harmony will monitor the Project and assess impacts as well and comply with all requirements set forth in the Certificate.	5.1, 5.2, 6.17

3.5 Design and Construction Limitations

When determining the location for the proposed Project, Harmony considered the following design and construction limitations: solar resources, interconnection to the electrical transmission system, environmental constraints, and landowners and local support. As discussed in Section 1.2.4, Harmony has addressed the meteorological conditions of the Project Area to ensure that the site has an economically viable solar resource.

Further, capacity for interconnection to the existing electrical transmission system was also a significant factor in Project development and design. The interconnection capacity in this location is expected to be more than sufficient for the Project, and Harmony is currently within MISO's Definitive Planning Phase (DPP). Harmony's analysis indicates there is sufficient capacity at this location.

Site control was also critical to the Project, as Harmony does not have eminent domain powers. Harmony secured voluntary lease agreements with supportive landowners in the Project Area.

Environmental constraints also affected the Project's design and construction, including:

- Resident, citizen, and Township input on the design of the solar facilities for their community and needs (i.e., nearby participating landowner input to create more distance to the solar facilities from their property); and
- Setback requirements from features including roads and property lines.

See Section 6 for more detailed discussion of the site-specific resources and mitigation measures utilized.

3.6 Economic Considerations

As an IPP, Harmony's main goal is to provide the lowest cost electricity that the Project can produce. Harmony intends to compete in the market for a power purchase agreement (PPA) with a third-party utility or other corporation. To be awarded a PPA, Harmony will need to prove the long-term cost effectiveness of the Project's energy. The major cost components of a solar energy facility are:

- Solar resource;
- Transmission availability;
- Equipment costs;
- Engineering and construction costs;
- Landowner payments;
- Taxes and fees; and
- Operations and maintenance costs.

Harmony's model and the Project offer an opportunity to maximize the economic attributes that benefit the local community and deliver an overall cost-competitive energy project. The Project's strong solar resource (see Section 1.2.5), low transmission upgrades and ability to create a construction-efficient layout are some of the major benefits of the Project.

Harmony also values the local economic benefits of the Project. Over 200 jobs are anticipated to be generated related to the Project, including 12 new full-time jobs associated with the operation of the Project with an expected annual impact of approximately \$700,000 per year. These jobs will provide opportunities for state and local workers and construction will generate additional local business revenue due to people living, working and spending in the local area.

During operation, the Project will also broadly benefit the local communities through Harmony's landowner payments, tax revenue, jobs and charitable donations estimated to total approximately \$45 million over the first 25 years of operation.

Landowners participating in the Project will receive annual lease payments as a part of the Project. These payments will provide significant revenue to the landowners and diversify the income of the landowners beyond the traditional agricultural farming markets. This diversification of revenue will also benefit the local economy.

Once operating, the Project is expected to generate approximately \$9 million in tax revenue over the first 25 years. Those dollars will be allocated to the local taxing authorities based on the local Mill Rates. The primary local taxing authorities in the Project Area include Cass County, Harmony Township, Central Cass and Mapleton School Districts, and other smaller taxing authorities. As

the first IPP owned utility scale solar project in North Dakota, the manner in which the Project will be taxed and assessed for purposes of property taxes has not yet been confirmed. Harmony is working with the North Dakota Office of State Tax Commissioner to clarify how the Project would be taxed. For the purposes of this Application, a conservative approach to estimate tax revenue was utilized under NDCC Section 57-33.2.

Once Harmony is in operation, the Project will also make annual charitable contributions to benefit the local area near the Project. Harmony has committed to \$40,000 per year for the first 20 years of operations (calculated using \$200 per MW of capacity per year). These charitable contributions could include a community fund or an education fund.

4.0 DESCRIPTION OF THE PROPOSED FACILITY

4.1 Project Components

4.1.1 Solar Facility

Solar Panels

The Project will utilize photovoltaic (PV) panels with tempered glass varying in size approximately 4 to 6.5 feet long by 2 to 3.5 feet wide, and 1 to 2 inches thick. The panels will be installed on a tracking racking system that utilizes galvanized steel and aluminum for the foundations and frame. Each rack will contain multiple panels. On the tracking system, panels will be up to 15 feet in height. Height may vary due to manufacturer, topography and vegetation constraints. Depending on the technology selected, the PV panels may have an aluminum frame, silicon, and weatherized plastic backing or a side-mount or under-mount aluminum frame, heat strengthened front glass, and laminate material encapsulation for weather protection.

To limit reflection, solar PV panels are constructed of dark, light-absorbing materials. Today's panels reflect as little as two percent of the incoming sunlight depending on the angle of the sun and assuming use of anti-reflective coatings. The solar array will occupy most of the Project site for the solar facilities.

Linear Axis Tracking System

A linear axis tracking system tracks the solar resource throughout the day. The panels are generally aligned in rows north and south and face east in the morning, perpendicular to the ground during mid-day, and then west in the afternoon. The panels are rotated by a small motor to slowly track with the sun throughout the day.

Images 1-3 below visually show the general racking equipment and dimensions of a linear axis tracking system.

Image 1: Tracking System Racking



Image 2: Approximate Tracking System Dimensions

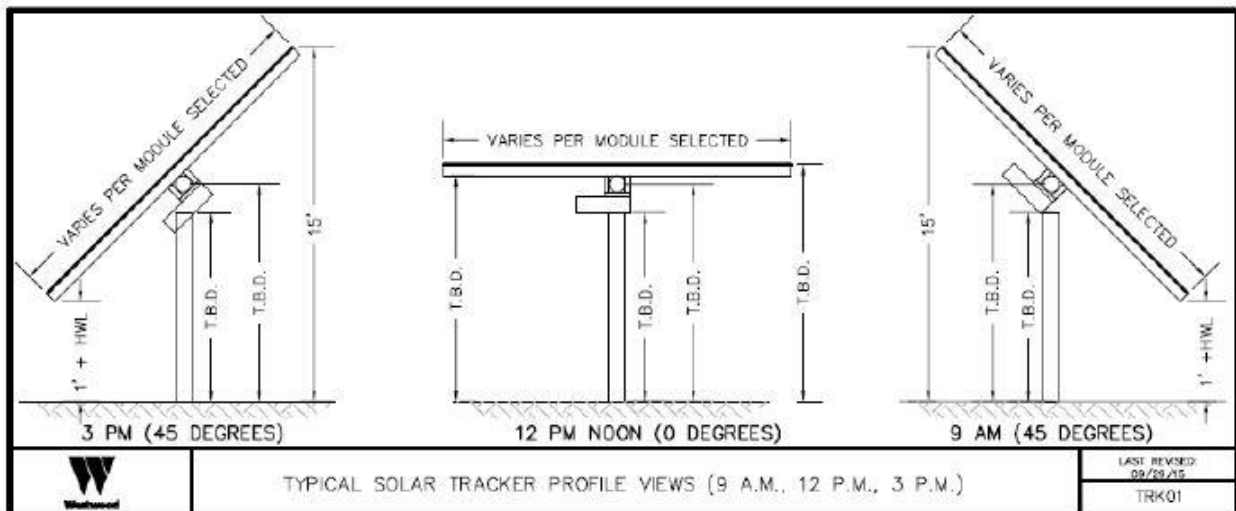

Image 3: Standard Steel Pier Foundations*Inverters*

Inverters convert the direct current (DC) output of the panels to AC, which is required for delivery to the electrical transmission grid. The panels deliver DC power to the inverters through cabling that will typically be located in an underground trench (approximately three feet deep and one to two feet wide) or, aboveground cable trays or conduit. Each inverter pad will also include one or more transformers to which the inverters will feed electricity. After the inverter has converted the electricity from DC to AC, the electricity is stepped-up via a transformer from low-voltage to medium voltage (up to 34.5 kilovolts [kV]). The final number of inverters for the Project will depend on the inverter size, inverter and panel availability as well as the final panel configuration and facilities selected for construction. The Project's preliminary design has proposed 80 central inverter skids and electrical cabinets (one inverter is required for every 2-3 MW). These structures enclose the inverter and communication equipment. The cabinets may be placed atop a concrete slab or pier foundations and typically measure 12 feet by 35 feet. The inverters are within the interior of the Project along access roads. Overhead shade will be 10 to 12 feet tall.

Access Roads

The Project will include approximately 20 miles of graveled access roads that lead to the inverters and Project substation for operation and maintenance. The final length of the access roads will depend on the equipment selected and final engineering. These roads are generally 16 feet wide and wider along curves. There are seven access points to the Project from existing township roads. These entrances will have locked gates.

Some upgrades or other changes to the public roads may be required for construction or operation of the Project. Harmony will work with the appropriate road authorities to facilitate and pay for required upgrades that meet the required public standards. Upgrades or changes could include, but are not limited to, dust control, road improvements, additional aggregate, field access or driveway changes.

Safety Features

A 6-foot chain link with 1-foot of barbed wire will comprise the security fence that surrounds the perimeter of the Project. The Project will also have security cameras. Harmony may have security lighting at the entrances that will be down lit. There may be lights at each inverter that will be down lit and switch controlled for repair purposes. For more detail about the lighting proposed at the Project site, see Appendix A.

4.1.2 Associated Facilities

Project Substation

The Project substation will be a 34.5/345 kV step-up substation with metering and switching gear required to connect to the transmission grid. It will be designed according to regional utility practices, Midcontinent Independent Transmission System Operator Standards, Midwest Reliability Organization Standards, National Electrical Safety Code, and the Rural Utility Service Code. The area around the substation will be graveled and fenced. The substation's area will be approximately 500 feet by 500 feet once construction is complete. The Site Plan located in Appendix A is a draft and the location of the substation is subject to change as a result of final engineering. The Project substation may be located anywhere along the southern security fence in Section 11. As stated above, a final Site Plan will be submitted to the Commission and Township prior to construction.

Operation and Maintenance Facility

An O&M building will provide access and storage for Project maintenance and operations. The O&M facility will be co-located with the Project substation. The Project will obtain a building permit from Harmony Township prior to construction. The buildings typically used for this purpose are approximately 2,000 to 4,000 square feet and house the equipment to operate and maintain the Project.

Parking

A parking lot will be located adjacent to the O&M building and will be approximately 500 square feet. Harmony will comply with all off-street parking provisions detailed in Article 6 of the Harmony Zoning Ordinance.

Weather Stations

The Project will include at least two weather stations up to 20 feet in height. Both weather stations will be within the security fence; the final locations will be determined following final engineering.

4.1.3 Temporary Facilities

Harmony will utilize three temporary laydown areas within the Project Area, totaling approximately 44.8 acres. These areas will serve both as a parking area for construction personnel and staging area for Project components during construction. These laydown areas are within the security fence. After construction, they will be reseeded using a pollinator friendly seed mix described in Section 6.14.

4.2 Project Layout

The Project's final layout will optimize electrical generation and efficiency of the solar resource while avoiding and minimizing environmental, cultural, and infrastructure impacts. The Project's facilities will be sited to comply with the townships setback requirements, where applicable, as well as other voluntarily-imposed setbacks. To the extent applicable, the Project will also comply with all other local, state, and federal regulatory standards.

The township road and utility setback regulations are provided in Table 4-1. Harmony will meet all township setbacks.

Table 4-1: Harmony Township Setback Requirements

Feature	Township Setback Requirement (feet)	Project Design
Road Rights-of-Way	100	At its closest, Project facilities are at least 120 feet from these features
Front Yard from Township Roads	75	
Side Yard	50	
Rear Yard	50	

The Project's proposed components include PV modules mounted on a linear axis tracking system and inverters. The modules vary in size with approximate dimensions of 4 to 6.5 feet long by 2 to 3.5 feet wide, and 1 to 2 inches thick. The foundations of the racking system will likely be a driven steel pier and likely will not require concrete, although some concrete foundations may be required. Geotechnical soil testing will determine final installation process. Areas of bare ground at the facility will be re-vegetated with a low-growing seed mix.

The modules will be electrically strung together to meet at one of the inverters. The inverters will convert the DC power from the modules to AC power. Additionally, a transformer will step up the voltage of generated electricity to meet the local interconnection voltage of the transmission grid. From the inverters, electrical cable will be buried underground to the point of interconnection. Here the system will interconnect to the existing transmission infrastructure. Harmony has secured all private easements for its facilities and has or will secure permits and other authorizations from the state, county and township governments, as needed.

The Project will use a Supervisory Control and Data Acquisition (SCADA) system, which allows remote control and monitoring of the status of the Project. The monitoring system provides status views of electrical and mechanical data, operation and fault status, meteorological data, and grid station data. For security, the Project will be fenced and have site security cameras. Access to the Project Area is through lockable gates.

4.3 Estimated Project Facility Impacts

Table 4-2 describes the land use conversion and temporary impacts of the Project.

Table 4-2: Estimated Impacts from Project Facilities

Description of Impact	Project Facilities	Acres of Impact
Direct Impact	Access Roads	38.5
	Inverters	0.8
	Project substation and O&M Facility	2.4
	Subtotal	41.7
Conversion to Grassland	Laydown Areas	48.2
	Area within the Security Fence less direct impacts and laydown areas	1,271
	Subtotal	1,319.2
Land Use Conversion	Total	1,360.9
Temporary Impact	Electrical Cables (outside security fence)	1.1
	Project Total	1,362.0

5.0 ENGINEERING AND OPERATIONAL DESIGN ANALYSIS

5.1 Project Construction

5.1.1 Overview of Activities

A variety of activities must be completed to carry the Project through construction. Below is a preliminary list of activities necessary to develop the Project. Pre-construction, construction, and post-construction activities for the Project include:

- Pre-construction
 - Geotechnical analysis;
 - Design substation and electrical collection system;
 - Design solar array, access roads, and O&M building;
 - Underground utility discovery; and
 - Procure all necessary facility components (solar panels, tracking system, transformers).
- Construction
 - Site preparation, grubbing, and grading;
 - Construct laydown areas and set up temporary job site trailers;
 - Civil construction of access roads;
 - Install PV mounting posts;
 - Install underground collection system;
 - Install electrical enclosure/inverter;
 - Tracker installation;
 - PV module installation; and
 - Construct Interconnection Tie.
- Post-construction
 - Restore disturbed areas not intended for permanent above ground facilities;
 - Test facility; and
 - Begin commercial production.

5.1.2 Construction Activities

After the necessary permits are received, construction will begin with the initial site preparation work (such as installing erosion and sediment controls, vegetation removal, and grading), workforce mobilization, and construction of general site improvements, such as access improvements (if necessary) and the staging/laydown area.

Areas of the site to be graded will have topsoil and organic matter stripped and segregated from the subsoil. Topsoil shall have temporary and permanent stabilization measures established in accordance with the Project's storm water pollution prevention plan. Internal roads will be constructed of inorganic fill (road aggregate base) to match the surrounding existing ground elevations to allow existing drainage patterns to persist. Once the necessary grading is complete, subsoil will be replaced, followed by topsoil, blending the grade into existing topography.

Geotechnical and pull testing studies will be performed to determine the topsoil and subsoil types, and the mechanical properties of the soils. These variables will be used to engineer the solar array foundation system. Typically, the foundation is a steel pile, which is driven into the ground with a hydraulically powered high-frequency hammer mounted on a tracked carrier. The piles are installed at pre-defined locations throughout the array area to a depth of 8' to 14' below grade, depending on soils, frost depth, and other factors.

The electrical collection system includes buried cables connecting the solar arrays to the inverters and the inverters to the point of utility interconnection. The cables will be installed in trenches or ploughed into place at a depth of at least 48 inches to the top of the lines. During trench excavation the topsoil and subsoil will be removed and stockpiled separately. Once the cables are laid in the trench, the area will be backfilled with subsoil followed by topsoil.

The solar energy system (solar arrays and collection and distribution systems) will be installed next along with access roads within the arrays. The solar facilities will be constructed in blocks, and multiple blocks could be constructed simultaneously. Electrical testing and equipment inspections will be conducted on each solar energy system. If concrete foundations are used for electrical equipment (inverters or transformers or other electrical cabinets) they will be precast and assembled off-site.

During construction, equipment and work vehicles would travel to and from the site. Construction is anticipated to be consistent throughout the construction season when the majority of the access road construction, electrical and substation work is taking place. Typical construction equipment such as scrapers, dozers, dump trucks, watering trucks, motor graders, vibratory compactors, and backhoes will be used during construction. Specialty construction equipment that may be used during construction will include:

- Skid steer loader;
- Vibratory pile driver;
- Medium duty crane;
- All-terrain forklift;
- Concrete truck and boom truck;
- High reach bucket truck; and
- Truck-mounted auger or drill rig.

Upon completion of construction, heavy equipment will be removed from the site.

5.1.3 Construction Management

Harmony will designate an on-site construction manager. This manager's responsibilities include scheduling and coordinating the activities of engineering, procurement and construction contractors. The construction manager will be supported by other members of Harmony's team who specialize in engineering, permitting, meteorology, environmental compliance, real estate and Geographic Information Systems (GIS) mapping. Harmony will also supply a landowner and

community liaison during construction to facilitate community relations and coordinate operations between the construction team, local residents and farmers, and local government.

Throughout the construction phase, ongoing coordination occurs among the Project's development, design, and construction teams. The construction manager coordinates execution of the work. This coordination includes safety and quality control programs, cost and schedule forecasting, as well as site security and ongoing communication with local officials, citizen groups, and landowners.

Following commissioning and commercial operation, the care, custody, and control of the facility transfers from the construction team to the operations staff. The construction manager works with the operations staff, the equipment suppliers, and other construction and maintenance personnel to ensure a smooth transition from the start of construction to the commercial operation date of the Project. The operations staff will have full responsibility for the facility to ensure operations and maintenance are conducted in compliance with approved permits, prudent industry practice and the equipment manufacturer's recommendations.

5.1.4 Commissioning

Upon completion of the construction phase, the Project will undergo detailed inspection and testing procedures before being commissioned. Inspection and testing will occur for each component of the solar array, as well as the associated communication, meteorological, collection, and SCADA systems.

5.2 Project Operation and Maintenance

Harmony will be professionally maintained and operated. Primary tasks include scheduled monthly and quarterly inspection(s) of electrical equipment, vegetation management as well as snow removal on access drives.

The expected service life of the proposed facilities is 25 to 40 years, and Harmony estimates that the Project will result in up to 12 full-time permanent positions to operate and maintain the facilities. A maintenance plan will be created for the Project to ensure the performance of the solar facilities, including a scheduled check of the main items and a predictive maintenance approach of the devices subjected to derating/degradation. Derating/degradation refers to the known process of components losing some efficiency or otherwise degrading over the course of the Project's life cycle; like all technology and physical components, a certain amount of this is unavoidable, and Harmony will plan for it and maintain the facility as needed. Once construction is complete, the solar facility will see one to two trucks on site daily, and at intervals associated with the maintenance schedule in Section 5.2.6 during normal operations. The main scheduled activities are described in more detail below in Sections 5.2.2 through 5.2.4.

All maintenance activities will be performed by qualified personnel. Maintenance activities will be performed during the day to the extent that they do not disrupt energy production. Upon occasion, it may be desirable to perform maintenance when the sun is down. Activities that have the potential for substantial noise generation will be performed during the day to minimize impacts in areas where residents are present. As an example, if a module needs repair, that particular

section of the array can be disconnected from the array by opening the combiner box circuit. The module can then be replaced, and the combiner box circuit closed. Additionally, the power production circuits are separated from the tracking circuits. This allows the PV modules to operate during an unscheduled outage of the tracker system.

There will be an area for the storage of the spare parts and the tools as noted in Section 5.2.5 below. The generating facility will be operated through a real-time control system for most operations functions. All the monitored data will be managed by Harmony or contracted out to a qualified subcontractor. Onsite operation will be performed from time to time as required for certain resets and troubleshooting activities.

5.2.1 Supervisory Control and Data Acquisition System

The solar arrays will communicate directly with the SCADA system for remote performance monitoring, energy reporting and troubleshooting. The SCADA system provides data on solar generation and production, availability, meteorology, and communications. The SCADA system allows 24/7 monitoring of, and communications with, the Project and relays alarms and communication errors. Harmony will oversee on-site service and maintenance for the Project. Permanent, full-time staff will remain on-site to perform these duties.

5.2.2 Equipment Inspection

Inspection of the main equipment will occur at regular intervals, including:

- PV panels: visual check of the panels, tracking system and surrounding grounds to verify the integrity of the panels and tracking structure, the presence of animals and nests, etc.
- Inverters, transformer and electrical panels: visual check of the devices including the connection cabinet and the grounding network. Check for presence of water and dust;
- Electrical check: measurement of the insulation level and dispersion. Check of the main switches and safety devices (fuses);
- Noise: check of abnormal sounds; and
- Cabling and wiring: visual check of the buried and aerial electrical line and connection box to verify their status.

5.2.3 Performance Monitoring

Performance monitoring of the Project facilities will consist of a weekly or monthly download of the data acquired by the onsite meteorological station (energy produced, alarms, faults, etc.).

5.2.4 Facility Maintenance

Housekeeping of the Project facilities will include road maintenance, vegetation maintenance (method is to be determined; either traditional mowing or sheep and/or lamb grazers will be utilized), fence and gate inspection, lighting system checks, and PV panel washing (if required);

minimal to no washing is anticipated to be needed at Project facilities due to the naturally occurring and frequent precipitation).

5.2.5 Maintenance Schedule

Table 5-1 provides more information on the anticipated frequency of the operations and maintenance tasks associated with the Project. The table represents the anticipated preliminary frequency of these tasks; the frequency of inspection may be varied based on facility demands and experience with performance of certain components and project features.

Table 5-1: Operations and Maintenance Tasks and Frequency

Plant Device	Task	Preliminary Frequency
Photovoltaic Field	PV Modules visual check	Twice Yearly
	Wirings and junction boxes visual check	Twice Yearly
	PV strings measurement of the insulation	Twice Yearly
	PV strings and string boxes faults	Twice Yearly
	PV panels washing	No regular washing planned (only as site-specific conditions warrant)
	Vegetation Management (if necessary at site)	Up to three times a year depending on site conditions
Electric Boards	Case visual check	Twice Yearly
	Fuses check	Twice Yearly
	Surge arresters check	Twice Yearly
	Torque check	Twice Yearly
	DC voltage and current check	Twice Yearly
	Grounding check	Twice Yearly
Inverter	Case visual inspection	Twice Yearly
	Air intake and filters inspections	Twice Yearly
	Conversion stop for lack of voltage	Twice yearly
	AC voltage and current check	Twice yearly
	Conversion efficiency inspection	Twice yearly
	Datalogger memory download	Twice yearly
	Fuses check	Twice yearly
	Grounding check	Twice yearly
Support Structures	Torque check	Twice yearly
	Visual check	Twice yearly
	PV modules torque check on random sample	Twice yearly

5.2.6 Operations and Maintenance Building

As described above, the O&M facility will be located adjacent to the Project Substation. The size of a typical building used for this purpose is between 2,000-4,000 feet. It will house the necessary equipment to operate and maintain the Project. The O&M building will allow maintenance staff

to conduct on-site diagnostics, repairs, predictive maintenance, and preventive maintenance activities. This facility will also serve as the warehouse for critical spare parts.

5.3 Decommissioning and Restoration

At the end of the Project's useful life, Harmony will either take necessary steps to continue operation of the Project (such as retrofitting) or will decommission the Project and remove facilities. Decommissioning activities will include:

- Removing the solar arrays, transformers, electrical collection system, fencing, lighting and substations, and possibly the O&M facility (the O&M facility may be useful for other purposes);
- Removal of underground cables to a depth of twenty-four inches;
- Removal of buildings and ancillary equipment to a depth of four feet;
- Removal of surface road material and restoration of the roads to substantially the same physical condition that existed immediately before construction, unless the landowner requests in writing that the access roads be retained;
- Site restoration and reclamation to the approximate original topography that existed prior to construction of the facility with topsoil respread over the disturbed areas at a depth similar to that in existence prior to the disturbance;
- Grading, adding topsoil, and reseeded according to the NRCS technical guide recommendations and other agency recommendations, areas disturbed by the construction of the facility or decommissioning activities, unless the landowner requests in writing that the access roads be retained; and
- Standard decommissioning practices would be utilized, including dismantling and repurposing, salvaging/recycling, or disposing of the solar energy improvements, and restoration.

Timeline

Decommissioning is estimated to take two to three months to complete and the decommissioning crew will ensure that all equipment is recycled or disposed of properly.

Removal and Disposal of Project Components

The removal and disposal details of the Project components are found below.

- Modules: Modules inspected for physical damage, tested for functionality, and removed from racking. Functioning modules packed and stored for reuse (functioning modules may produce power for another 25 years or more). Non-functioning modules packed and palletized and sent to the manufacturer or a third party for recycling or another appropriate disposal method;
- Racking: Racking uninstalled, sorted, and sent to metal recycling facility;
- Poles: Steel poles removed and sent to a recycling facility. Holes backfilled;
- Wire: belowground wire abandoned in place at depths greater than four feet;
- Conduit: Aboveground conduit disassembled onsite and sent to recycling facility;

- Junction boxes, combiner boxes, external disconnect boxes, etc.: Sent to electronics recycler;
- Inverter: Sent to manufacturer and/or electronics recycler. Functioning parts can be reused;
- Concrete pad(s): Sent to concrete recycler;
- Fence: Sent to metal recycling facility; and
- Computers, monitors, hard drives, and other components: Sent to electronics recycler. Functioning parts can be reused.

Restoration/Reclamation of Facility Site

After all equipment is removed, the facility will be restored. Holes created by poles, concrete pads, and other equipment will be filled in with soil to existing conditions and seeded. This will include the revegetation.

Harmony reserves the right to extend operations instead of decommissioning at the end of the site permit term. In this case, a decision may be made on whether to continue operation with existing equipment or to retrofit the facilities with upgrades based on newer technologies.

6.0 ENVIRONMENTAL ANALYSIS

As part of the environmental analysis for this Application, Harmony identified a Study Area that consists of the area within a 3-mile radius of the Project Area (refer to Section 1.2.1 for a description of the Project Area).

The Study Area is located within Level IV Lake Agassiz Plain Ecoregion (EPA 2017). This ecoregion consists of thick lacustrine sediments underlain by glacial till that formed when Glacial Lake Agassiz, one of the last proglacial lakes to fill the Red River Valley since the beginning of the Pleistocene, covered the area. The Red River of the North creates the eastern border of this ecoregion and the river valley exhibits a poorly defined floodplain and very low gradient which makes this area prone to flooding. The Lake Agassiz Plain Ecoregion has fewer lakes and potholes than the surrounding ecoregions. Soils in this ecoregion range from silty to clayey in texture, typically have high water tables, and are considered highly productive farmland.

Historically the area was predominantly tall grass prairie, which left rich, deep topsoil deposits and abundant organic material. Because of the productive soil and relatively level topography, the region is almost entirely cultivated and tilled. The principal crops grown in the Study Area are soybeans, corn, wheat, and sugar beets.

The Study Area is in a predominantly rural setting about 8 miles northwest of the Fargo-Moorhead metropolitan area. The nearest towns are Casselton and Mapleton which are about 3.6 and 4.5 miles to the southwest and southeast of the Project Area, respectively.

Generally, the existing environment of the Study Area described in the following sections is based on publicly available information from agencies. Harmony conducted field surveys within the Project Area to provide site-specific information on wetlands, including invasive and noxious weeds, and cultural resources. The results of these surveys are summarized in the applicable sections below. Impacts are quantified where possible based on either publicly available information or field survey data. Project impacts are calculated as follows:

- Land use conversion from agricultural and developed land to solar facility and grassland of 1,360.9 acres, consisting of:
 - Direct impacts, or land use conversion from agricultural and developed to solar facility (approximately 41.7 acres), which includes the 16-foot-wide access roads, 80 inverters with a 12- by 35-foot footprint, and the 2.4-acre Project substation and O&M facility footprint;
 - Land use conversion from agricultural and developed land to grassland (approximately 1,319.2 acres), which includes the area within the security fence, less the direct impacts, and consists of the laydown areas, land beneath the solar arrays, and unused space within the security fence that will be taken out of crop production and planted with an approved seed mix; and
- Temporary impacts (approximately 1.1 acres) which are associated with the electrical cables connecting the groups of solar arrays outside the security fence (an approximate 1,855 feet in length by 25-foot-wide temporary disturbance corridor).

Note that as described in Section 1.2, there are 1,662 acres within the Project Area, 1,362.0 of which are accounted for in the impacts described above. There are 300 acres outside the fence but within the Project Area that would continue to be used for crop production, pending landowner preferences; therefore, this area is not included in the impact discussions below. Additionally, the footprint of impacts described above will depend on final engineering.

6.1 Demographics

The Study Area is in a rural area within Harmony Township and no incorporated communities are located within the Study Area. The incorporated communities that are geographically closest to the Project Area are Casselton (3.6 miles southwest), Mapleton (4.5 miles south/southeast), and Amenia (5.2 miles northwest). The nearest metropolitan area is Fargo-West Fargo which is approximately 8.4 miles southeast of the Project Area and outside of the Study Area.

Table 6-1 presents population and economic information gathered from the U.S. Census Bureau 2010 Census and 2012-2016 American Community Survey 5-year Estimates about North Dakota and Cass County (U.S. Census Bureau 2010 and 2016). The 2010 U.S. Census gathered a wide variety of data points. The discussion herein does not address every demographic measure, but instead addresses the most applicable statistics related to the Project. The demographic characteristics that relate closest to the Project include: total population, vacant housing units, per capita income, the percentage of the population below poverty level, and the unemployment rate (see Table 6-1).

Based on the 2010 U.S. Census, the population of Cass County is 149,778 people, which represents 22 percent of the total population of North Dakota. The per capita income of Cass County is \$32,485, which is slightly lower than the state average. Although the unemployment rate in North Dakota and Cass County is relatively low at 2.8 and 2.9 percent, respectively, slightly more than 11 percent of individuals in the state and county are classified as living below the poverty level. The primary industries in Cass County are classified as educational services, health care, and social assistance (25.1 percent), followed by retail trade (12.2 percent), arts, entertainment, and recreation, and accommodation and food services (9.8 percent), professional, scientific, and management, and administrative and waste management services (9.6 percent), and manufacturing (9.1 percent) (U.S. Census 2016).

According to the U.S. Census Bureau 2012-2016 American Community Survey 5-year Estimates, approximately 4,559 vacant housing units exist in Cass County. Of these, about 3,610 of the total vacant housing units in Cass County are located in the nearby Fargo metropolitan area (U.S. Census Bureau 2016). In addition, numerous hotels, motels, and campgrounds are available in the Fargo-Moorhead metropolitan area.

Table 6-1: Demographic Information

State/County	Total Population	Vacant Housing Units	Per Capita Income (Dollars)	Percentage of Population Below Poverty Level (All People)	Unemployment Rate (percent)
North Dakota	672,591	44,971	33,107	11.2	2.8
Cass County	149,778	4,559	32,485	11.8	2.9

Sources: U.S. Census Bureau 2010 and 2016.

6.1.1 Demographic Impacts/Mitigation

The Project is designed to be socioeconomically beneficial to landowners, local governments, and communities. Landowner compensation is established by voluntary Land Lease agreements. The Harmony Education Fund will also contribute charitably and economically to the local school districts within the Project Area.

In general, the land surrounding the solar facility would continue to be farmed. The annual lease payments to landowners are designed to positively compensate the landowners for any land removed from agricultural production and the inconvenience of farming around the new obstacles in their field.

Construction of the Project would provide temporary increases to the revenue of the area through increased demand for housing, lodging, food services, fuel, transportation and general supplies.

The Project will also create new local job opportunities for various trade professions that live and work in the area and it is typical to advertise locally to fill required construction positions. Opportunity exists for sub-contracting to local contractors for gravel, fill, and civil work. Additional personal income will also be generated by circulation and recirculation of dollars paid out by the Project as business expenditures and state and local taxes.

General skilled labor is expected to be available in Cass County or North Dakota to serve the Project's basic infrastructure and site development needs. Specialized labor will be required for certain aspects of the Project. It may be necessary to import specialized labor from other areas of North Dakota or neighboring states because the relatively short construction duration often precludes special training of local or regional labor.

No substantial effects on temporary or permanent housing are anticipated. During construction, out-of-town laborers will likely use lodging facilities nearby. The operations and maintenance of the facility will require few long-term laborers. The Project anticipates that sufficient temporary and permanent housing will be available within Cass County, and within the Fargo-Moorhead metropolitan area, to accommodate these laborers.

In general, the socioeconomic impacts associated with the Project will be positive; therefore, no mitigative measures are proposed. Wages will be paid, and expenditures will be made to local businesses and landowners during the Project's construction and operation. The construction and

operation of the Project will increase Cass County's tax base. In addition, lease payments paid to landowners will offset potential financial losses associated with removing a portion of their land from agricultural production.

6.2 Land Use, Ownership, and Management

Land Use

The Project is located within a rural landscape, and as such the primary land use in the Study Area is agricultural (95.5 percent; USGS, 2011; Figure 5). The remainder of the Study Area consists of developed land (4.0 percent) and a small amount of forested land (0.4 percent), open land (<0.1 percent), and open water (<0.1 percent). Developed land within the Study Area generally consists of public roads and utility infrastructure, such as the existing Bison substation. Forested land is a category in the USGS Gap Analysis Program (GAP) data used for Harmony's environmental analysis; however, forested land within the Study Area consists of isolated rows of relatively young trees that were planted for use as shelter belts or wind breaks along the edges of agricultural fields. Small areas of open land within the Study Area consist of shrub/scrub or herbaceous vegetation interspersed between agricultural fields and farmsteads, or areas of riparian vegetation along waterbody margins. The Lower Branch of the Rush River crosses through the Study Area and accounts for the small amount of open water noted in Table 6-2.

Table 6-2: Land Use Within the Study Area

Land Use Type	Acres in Study Area	Percent of Total Acreage
Agricultural	35,323.8	95.5
Developed	1,494.9	4.0
Forested	150.3	0.4
Open Land	3.1	<0.1
Open Water	16.2	<0.1
Total	36,988.3	100.0

Source: USGS, 2011

Farmsteads are sparsely scattered throughout the Study Area, generally situated near public roads. No known center pivot irrigation systems are present within the Study Area. Based on review of available aerial photography, approximately 67 occupied or occupiable residences are located within the Study Area; however, the Project will not cause displacement or relocation of residences.

To the best of Harmony's knowledge, no mining is taking place or has taken place in the Study Area. The nearest gravel pit is approximately 15 miles west of the Project.

Land Ownership and Management

All land within the Study Area is privately owned. Harmony has not identified any state or federal conservation areas, including but not limited to state parks, state recreation areas, state nature preserves and natural areas, scenic trails, wildlife refuges, U.S. Fish & Wildlife Service (USFWS)

wetland or grassland easements, or Waterfowl Production Areas (WPAs) within the Study Area. The closest state conservation area is the Magnolia State Game Management Area which is located approximately 14 miles west/southwest of the Project Area and outside of the Study Area.

6.2.1 Land Use Impacts/Mitigation

Land Use

Table 6-3 provides the total acres of each land use type that would be affected by construction and operation of the Project. The Project would affect agricultural and developed land; no forested land, open land, or open water is located within the Project Area.

Table 6-3: Land Use Impacts

Impact Type	Agricultural	Developed	Total
Direct	41.4	0.3	41.7
Conversion to Grassland	1,312.1	7.1	1,319.2
Land Use Conversion Subtotal	1,353.5	7.4	1,360.9
Temporary	0.8	0.3	1.1
Total	1,354.3	7.7	1,362.0

Source: USGS, 2011.

Agricultural land will be converted from an agricultural use to solar energy use for the life of the Project but preserved and the soils given the opportunity to rest and regenerate. Agricultural land within the fenced area of the solar facility will be converted to open, herbaceous (i.e., grassland) cover with the exception of the substation and O&M facility, inverters, and access roads which will be converted to developed land and impervious surfaces.

The conversion of agricultural land to grassland and low impact developed land within the fenced area of the solar facility will have a minimal impact on the rural character of the surrounding area or Cass County. As discussed further in Section 6.9, Land-based Economics, of the 36,988.3 acres in the Study Area, approximately 95.5 percent (approximately 35,323.8 acres) are classified as agricultural land. Direct impacts and conversion of 1,353.5 acres of agricultural land to developed and grassland within the fenced area of the solar facility would reduce the amount of agricultural land in the Study Area by 3.8 percent. Agricultural production would be allowed to continue in the area outside of the fence line of the solar facility during construction and operation of the Project.

Harmony will work with landowners to avoid and minimize detrimental impacts to agricultural land and crops during construction. If unavoidable impacts to crop planting, crop damage, soil compaction, or drain tile do occur, Harmony will compensate landowners or use restorative techniques (including but not limited to, drain tile repair and soil restoration) as mitigative measures.

There are no residences within the Project Area; the nearest residence is 1,085 feet from the Project Area. This residence is owned by a Project participant. No impacts to residences will occur as a result of the Project; therefore, no mitigation is proposed.

No mining activities are located within the Project Area and no impact on mining activities will occur as a result of the Project; therefore, no mitigation is proposed.

Land Ownership and Management

Land in the Project Area is privately owned. Harmony has not identified any federal or state conservation areas within the Project Area; therefore, no impacts to these areas would occur and no mitigation measures specific to conservation areas are proposed.

6.3 Public Services

Local Services

The Study Area is located in a rural part of eastern North Dakota that is mainly used for agricultural purposes. The majority of public services and infrastructure near the Project are located in the town of Casselton, which is approximately half mile southwest of the Study Area and 3.6 miles southwest of the Project Area. Casselton has a medical clinic, regional airport, police, fire and ambulance services, businesses, churches, and a public school for grades kindergarten through 12th grade. As mentioned in Section 6.1, the Fargo-West Fargo metropolitan area is located approximately 8 miles southeast of the Study Area and offers access to these services and more.

Electrical Service

Electrical service in the Study Area is provided by Otter Tail Power Company. There is an existing 345 kV transmission line operated by Otter Tail Power Company immediately adjacent to the south end of the Project Area that runs east-west (Figure 6). Additionally, the Bison Substation, where the Project transmission line will interconnect, is also located immediately adjacent to the southern border of the Project Area. The Bison Substation was the western terminus of the Fargo-St. Cloud CapX2020 Project. Additionally, there are multiple small overhead distribution lines connected to farmsteads throughout the Study Area.

Transportation

The Study Area is bordered on the south by Interstate 94 and on the west by State Highway 18; both roadways are approximately one mile from the Study Area. Roads within the Study Area are county or township roads and well-maintained gravel roadways used for local transportation and agricultural purposes.

A Burlington Northern Santa Fe (BNSF) railroad traverses the northern portion of the Study Area in a southeast to northwest direction and is 1.25 miles north of the Project Area at the nearest point. A second BNSF railroad that connects the towns of Mapleton and Casselton traverses the southern portion of the Study Area generally in an east-west direction. This railroad is 2.7 miles south of the Project Area.

There are no public airports in the Study Area. The closest public airport is the Casselton Robert Miller Regional Airport, approximately 3.5 miles southwest of the Study Area and two miles south of Casselton. There is one unregistered and private landing strip within the southern portion of

the Study Area, 2.4 miles south of the Project Area and 2.3 miles northwest of Mapleton (Figure 6). This landing strip is likely used to facilitate agricultural crop spraying.

Traffic

North Dakota Department of Transportation (NDDOT) traffic counts have not been conducted for any roads in the Study Area. The 2015 average annual daily traffic volumes indicated 1,215 vehicles on State Highway 18 and 16,645 on Interstate 94 approximately one mile west and south of the Study Area, respectively (NDDOT 2016). Traffic loads on the roadways in the Study Area can be attributed to agricultural production traffic and local resident use.

Water Supply

Rural water is supplied to the Study Area by Cass Rural Water District. It is common for rural residences in the area to utilize private wells for alternative uses, such as agriculture. According to North Dakota State Water Commission (NDSWC) data, there are nine domestic or stock wells in the Study Area, and none in the Project Area (Figure 9). There is one aquifer in the Study Area: the West Fargo aquifer is on the eastern edge of the Study Area or 2.5 miles from the Project Area (Figure 9).

6.3.1 Public Service Impacts/Mitigation

Local Services

Impacts to local services in and around the Study Area are not anticipated; therefore, no mitigation is required.

Electrical Service

The Project is not anticipated to affect existing electrical service in the Study Area; therefore, no mitigation measures are required.

Transportation

Existing roadways within the Study Area will be utilized for access to the Project; however, construction of new access roads will be required within the security fence amongst the solar arrays. There will be five access points to the Project from existing township roads. Newly constructed permanent access roads will be 16 feet wide. In a letter dated October 17, 2017, NDDOT indicated the project should have no adverse effect on the North Dakota Department of Transportation highways (Appendix C).

The Project is not expected to impact the existing BNSF railroads in the Study Area; therefore, no mitigation is required.

ForgeSolar, on behalf of Harmony, conducted a glare analysis for the private airstrip within the Study Area (Appendix D). The analysis results indicate there will be no potential for temporary after-image glare from the Harmony Solar Project to this airstrip. As such, no mitigation is proposed.

Traffic

Access to the Project will utilize existing township, county or state roads. The roads used for access to the facility are shown on Figure 2.

During the construction phase, temporary impacts are anticipated on some public roads within the vicinity of Project facilities, primarily through additional traffic and slow-moving construction vehicles. Construction traffic will use the existing county and state roadway system to access the Project and deliver construction materials and personnel. The maximum construction workforce is expected to generate approximately 50 to 75 additional vehicle trips per day associated with materials delivery, and some additional light-duty truck traffic from construction workers accessing the site. This increased traffic may be perceptible to area residents, but the slight increase in volume is not expected to affect traffic function in the area. Slow-moving construction vehicles may also cause delays on smaller roads, similar to the impact of farm equipment during planting or harvest. However, Harmony will make appropriate accommodations to ensure local traffic has access through the area.

After construction is complete, traffic impacts during the operations phase of the Project will be minimal. A small maintenance crew driving through the area in light-duty pickup trucks on a regular basis will monitor and maintain the facilities as needed, but traffic function will not be impacted as a result.

Water Supply

Direct affects to residential water supply within the Study Area are not anticipated as a result of the proposed Project. Harmony will coordinate with individuals and/or the Cass County Rural Water District with respect to use of water supply, as necessary. The Project will not require appropriation of surface water or permanent de-watering. The Project may require one low-volume well for the O&M facility. Harmony will obtain a potable/wastewater permit from North Dakota Department of Health (NDDH) for the low-volume well prior to construction, if applicable. Harmony will construct the septic system in accordance with Cass County Amended Ordinance #2015-1 and work with the county to facilitate any reviews related to its installation or operation.

In the event that the Project requires temporary dewatering of groundwater during Project construction, it will be conducted under the requirements of the North Dakota Pollutant Discharge Elimination System (NDPDES) permit and Stormwater Pollution Prevention Plan (SWPPP). Harmony will follow the Construction and Environmental Disturbance Requirements as provided by NDDH.

6.4 Human Health and Safety

The Project facilities are located in a rural setting that has a low population density. Construction and operation of the Project will have minimal impacts on the security and safety of the local populace. Harmony is gathering information to coordinate with all emergency and non-emergency response teams for the Project, including law enforcement agencies, ambulance services, fire departments, and 911 services. Construction will comply with local, state, and federal regulations regarding installation of the facilities and standard construction practices. Established industry

safety procedures will be followed during and after construction of the Project. This will include clear signage during all construction activities and fencing of all facilities to prevent public access.

Electromagnetic Fields

The term electromagnetic field (EMF) refers to electric and magnetic fields that are present around any electrical device. Electric fields arise from the voltage or electrical charges and magnetic fields arise from the flow of electricity or current that travels along transmission lines, power collection lines, substation transformers, house wiring, and electrical appliances. The intensity of the electric field is related to the voltage of the line and the intensity of the magnetic field is related to the current flow through the conductors (wire). EMF can occur indoors and outdoors. The general consensus is that electric fields pose no health risk to humans (National Radiation Laboratory, Ministry of Health, New Zealand 2008).

With the proposed Harmony Project, the sources of EMF will be from electrical collection lines, that for the most part will be buried underground, and from the transformers installed at each inverter pad. EMF from underground electrical collection lines dissipates very close to the lines because they are installed belowground within insulated shielding. The electrical fields are negligible, and there is a small magnetic field directly above the lines that, based on engineering analysis, dissipates to levels indistinguishable from other sources within 70 feet on either side of the installed cable. Additionally, since the transformers are enclosed in a grounded metal case (shielded), they typically do not emit much EMF.

Hazardous Materials and Waste

The location of the Project in rural North Dakota makes contamination from large industrial or commercial activities unlikely. Based on a search of the NDDH's Underground Storage Tank (UST) list, there are no USTs in the Study Area or Project Area. No landfill locations or hazardous waste handler sites were listed by NDDH within the Study Area.

The U.S. Environmental Protection Agency (EPA) Superfund National Priorities List (NPL) database was reviewed to determine the potential for major hazardous material issues within the Study Area. There are no NPL sites or proposed NPL sites in North Dakota (EPA 2018).

During construction solid waste materials will include packaging materials (cardboard, pallet wood, plastic), scrap cable, and other typical municipal solid waste. No hazardous waste is expected to be generated by the site during construction or operation. While construction is active materials such as: diesel fuel, gasoline, motor oil, hydraulic fluids, lubricating oils for machinery and vehicles, solvents and adhesives, approved herbicides, batteries, paints, thinners, cleaning solvents, and transformer oil may be stored on site. During operations it is only anticipated that transformer oil and possibly grease would be stored on site. Materials will have a Material Safety Data Sheet (MSDS). During construction the following equipment and material is expected to be on site for a spill response (a reduced list of materials will be on site during operations): 55-gallon drums, bags of absorbent, absorbent pads, plastic sheeting, Tyvek suit and booties, nitrile gloves, safety goggles, 20-gallon portable preventive spill kit for each refueling truck, shovels, and fire extinguishing equipment.

Security

The Project is located in an area with a relatively low population density and crime rate.

Air Quality

North Dakota is one of only a handful of states that meet all national and state air quality standards. Ambient air quality monitoring continues to show exceptionally clean air in North Dakota (NDDH 2016).

6.4.1 Human Health and Safety Impacts/Mitigation

Electromagnetic Fields

The Project facilities are not significant sources of EMF exposure. The collection lines, for example, generate levels of EMF comparable to those generated by household appliances. As outlined in Section 6.2, the nearest residence to solar arrays is 1,085 feet and even greater distances to the nearest inverter and Project substation. Further collection lines will be buried to a depth of at least four feet. As such, impacts are not anticipated.

Hazardous Materials and Waste

It is not anticipated that hazardous waste sites will be encountered within the Project Area during construction. If hazardous waste sites are encountered, construction will be suspended and the NDDH will be contacted immediately to determine the best method for removal or clean up.

Any hazardous materials used for the construction of the Project will be contained according to the NDPDES Permit. In addition, a SWPPP will be developed as part of the NDPDES permit. Harmony does not anticipate storing hazardous material on site during operations. As such, no underground storage tanks will be installed at the Project.

Security

No impacts on the security and safety of local communities from construction and operation of the Project are anticipated. The solar facility will include a 6-foot high chain link fence with an additional foot of three strands of barbed wire fencing around the perimeter of Project facilities. The O&M building will also be a secure and locked facility.

Air Quality

Temporary air quality impacts caused by construction-vehicle emissions and fugitive dust from construction activities may occur but will be minimal and temporary. No impacts to air quality from the operations of the Project are anticipated. Consistent with the recommendations provided in NDDH's October 11, 2017 letter, the Project will implement Best Management Practices (BMPs) to minimize fugitive dust (Appendix C). Harmony will minimize and manage dust emissions during construction. Should any complaints arise, they will be handled in an efficient and effective manner.

6.5 Sound

Noise is measured in units of decibels (dB) on a logarithmic scale. Because human hearing is not equally sensitive to all frequencies of sound, certain frequencies are given more “weight.” The A-weighted decibel scale (dBA) is used to reflect the selective sensitivity of human hearing. This scale puts more weight on the range of frequencies that the average human ear perceives, and less weight on those that we do not hear as well, such as very high and very low frequencies. Common sound sources within an agricultural and/or rural environment include, but are not limited to, sound from farm equipment such as tractors and combines, sound generated from traffic on roadways, sounds from birds, and wind rustling through the vegetation. Typically, the ambient acoustic environment of a rural or agriculturally-oriented community has equivalent continuous sound levels (Leq, which is an energy-based time-averaged noise level) ranging from 30 dBA to 60 dBA.

Background noise in the vicinity of the Project facilities is typically a result of farming equipment/operations, wind, and vehicles. A comparison of typical noise-generating sources is outlined below in Table 6-4.

Table 6-4: Decibel Levels of Common Noise Sources

Sound Pressure Level (dBA)	Noise Source
140	Jet Engine (at 25 meters)
130	Jet Aircraft (at 100 meters)
120	Rock and Roll Concert
110	Pneumatic Chipper
100	Jointer/Planer
90	Chainsaw
80	Heavy Truck Traffic
70	Business office
60	Conversational Speech
50	Library
40	Bedroom
30	Secluded Woods
20	Whisper

Source: MPCA, 2008

6.5.1 Sound Impacts/Mitigation

During construction, noise will be emitted by the construction vehicles and equipment. The amount of noise will vary based on what type of construction is occurring at the facility on a given day. These noise impacts will be temporary.

The main source of noise from the Project during operation will be from the inverters, and to a lesser extent from the transformers and rotation of the tracking system. All electrical equipment will be designed to National Electrical Manufacturer Association Standards. Neither North Dakota nor Cass County has defined noise standards for solar facilities. However, the Commission has a requirement of a maximum of 50 dBA within 100 feet of an occupied residence for wind energy conversion facilities. Table 6-5 summarizes the anticipated distance to reach 50 dBA from a range of inverters and trackers under consideration for use at the Harmony Solar Project.

Table 6-5: Inverter and Tracker Noise Levels

Facility Type	Equipment Model	Distance to 50 dBA
Inverter	PE HEC-US V1500	85 feet
	SMA Sunny Central 2750-EV-US	160 feet
	ABB PCS980	125 feet
Tracker	ATI DuraTrack HZ v3	5 feet

The results of noise modeling conducted by technology manufactures outlined in Table 6-5 show that noise levels will be less than 50 dBA between 85 to 160 feet from the inverter, depending on which model is selected. As such, even if a requirement of no more than 50 dBA within 100 feet of an occupied residence were imposed, the Project would meet the requirement, as the closest home to the facility is 1,085 feet away from the edge of a solar array. Further, because the inverters are typically located within the middle of the solar arrays, the noise levels from Project equipment are not expected to be discernible from background noise levels at homes in the vicinity.

During construction, Harmony plans to limit construction to daylight hours. No noise impacts are anticipated during operation; therefore, no mitigation measures are proposed.

6.6 Visual

The topography of the Project Area is flat with elevations ranging from 915 to 925 feet above sea level and slopes less than 1 percent (Appendix A). The lower elevations are located near the Lower Branch Rush River. As discussed in Section 6.2, land use within the Study Area is predominantly agricultural, with corn being the most common crop. There are 67 residences within the Study Area, the closest of which is 1,085 from the Project Area. These residences, and the existing high voltage transmission lines in the Project vicinity are focal points in the dominant open space of the Project vicinity.

6.6.1 Visual Impacts/Mitigation

The Project will convert approximately 1,360.9 acres of land (a mixture of agricultural land [1,353.5 acres] and developed land [7.4 acres]; see Table 6-3 in Section 6.2.1) to a solar facility characterized by complex geometric forms, lines, and surfaces that may be novel to and divergent from the surrounding rural landscape. Construction activities will occur during daylight hours, limiting impacts of lighting on light-sensitive land uses.

Most of the developed area will be utilized with rows of solar PV panels. Solar PV employs glass panels that are designed to maximize absorption and minimize reflection to increase electricity production efficiency. The images in Section 4.1.1 provide a reference for how the Harmony Solar Project will appear during operation. To limit reflection, solar PV panels are constructed of dark, light-absorbing materials and covered with an anti-reflective coating. Today's panels reflect as little as two percent of the incoming sunlight depending on the angle of the sun and assuming use of anti-reflective coatings.

The solar arrays will occupy most of the disturbed area for the solar facility. The electrical transformers and inverters, a substation and O&M area, and access roads will utilize the rest of the disturbed area. Most of the facility, including the solar arrays, will be low-profile. The Project substation will be of similar vertical profile as the existing Basin Substation adjacent to the Project Area.

The solar arrays will be visible from adjacent roadways and parcels but given their relative low profile and the fact that all the facilities will be fenced for security, they will not be visible from long distances. The surrounding land use is cultivated crop fields, with a snowmobile trail within two miles of the Project Area (see Section 6.8). Snowmobilers may be able to see the solar facility from the trail, especially when crops are absent; however, the Project will not affect the recreational use of the snowmobile trail. As described above, the solar panels are specifically designed to absorb light, minimizing glare; therefore, no negative effects to road or air travel will occur (see Section 6.3 and Appendix D for this analysis).

As previously mentioned, the closest residence to the Project Area is 1,085 feet on the northeast corner of the intersection of 33rd Street SE and 160th Street SE. This residence is owned by a Project participant, and Harmony has coordinated with the owners and shifted the Project Area boundary to create distance from this residence.

Operation of the Project will require down lit security lighting at the entrance of the Project and there may be down lit, switch controlled lights at each inverter for repair purposes. Impacts to light-sensitive land uses are not anticipated given the rural Project location coupled with minimal required lighting for operations.

6.7 Cultural and Archaeological Resources

Area M Consulting (Area M) conducted Class I and Class III cultural resources inventories for the Project Area. A copy of the Class I and Class III inventory report is provided in Appendix E.

The Class I inventory included a review of documentation on file at the North Dakota State Historic Preservation Office (SHPO) regarding archaeological or historic sites, and historic architectural resources that may exist within one-half mile of the Project Area. The Class I inventory also reviewed previous cultural resources inventories conducted within one-half mile of the Project Area. While no previously recorded archaeological or historic sites, or historic architectural resources were noted within one-half mile of the Project, one previous Class I and Class III inventory report was noted. The study area of the previous inventory does not overlap with the Project Area.

Area M conducted a Class III inventory of the entire 1,662-acre Project Area in October 2016. The Class III inventory included pedestrian survey of the Project Area in 15-meter transects. Ground visibility at the time of survey ranged from 50 to 100 percent; no cultural resources were identified as a result of survey.

Area M submitted the Class I and Class III inventory report for the Project to the North Dakota SHPO in December 2016. In a letter dated September 28, 2017, the North Dakota SHPO concurred with Area M's recommendations that the Project would not affect historic properties listed in or

eligible for listing in the National Register of Historic Places (NRHP). A copy of the North Dakota SHPO's letter is provided in Appendix C.

6.7.1 Cultural and Archaeological Impacts/Mitigation

No archaeological or historic sites, or historic architectural resources were identified during Class I and Class III inventories of the Project Area; therefore, the construction and operation of the Project will not impact historic properties listed in, eligible for, or potentially eligible for listing in the NRHP.

Before construction of the Project begins, Harmony will prepare an Unanticipated Discoveries Plan (UDP) that will outline the steps to be taken if previously unrecorded cultural resources or human remains are encountered during construction.

6.8 Recreational Resources

As discussed in Section 6.2, there are no designated recreation areas or public or private parks in the Study Area. Portions of the East Central Valley snowmobile trail traverse the southern portion of the Study Area (Figure 7). Outdoor recreation activities in Cass County are more abundant in the western half of the county where there are three Wildlife Management Areas, several WPAs, and Private Land Open to Sportsmen. In a letter dated August 29, 2016, the North Dakota Parks and Recreation Department confirmed the Project will not affect state lands (Appendix C).

6.8.1 Recreational Resources Impacts/Mitigation

Impacts on recreational resources from construction of the Harmony Solar Project would be visual in nature. As discussed in Section 6.6.1, the Project may be seen from the East Central Valley snowmobile trail approximately two miles south of the proposed Project; however, the Project will not affect the recreational use of the snowmobile trail. As such, no mitigation is proposed.

6.9 Land-based Economics

Agriculture

According to the U.S. Department of Agriculture's (USDA's) 2012 Census of Agriculture, Cass County ranks first out of all North Dakota Counties for the total value of agricultural products sold. Of the 1,131,520 acres that comprise Cass County, approximately 1,107,398 acres (97 percent) are farmland. A total of 968 individual farms are located in Cass County, with the average farm size at 1,144 acres. The top crops (in acres) include soybeans, corn, wheat (predominantly spring wheat for grain), and sugarbeets, followed by dry edible beans, barley, and foraging crops (hay and haylage, grass silage, and greenchop) and barley. Colonies of bees top the list of livestock inventory in Cass County, followed by cattle, hogs and pigs, and sheep and lambs (USDA 2012).

The market value of agricultural production in Cass County in 2012 was approximately \$567,108. Crop sales accounted for approximately 97 percent of the total value of agricultural production, while livestock, poultry, and their products accounts for the remaining three percent (USDA 2012).

Prime farmland is discussed in Section 6.10 below.

Woodlands

No woodlands are located in the Study Area. As noted in Section 6.2, forested areas within the Study Area consist of isolated rows of trees that are used as shelter belts or wind breaks along the edges of agricultural fields.

6.9.1 Land-Based Economics Impacts/Mitigation

Agriculture

Direct impacts and conversion of approximately 1,353.5 acres of agricultural land as a result of the Project will not result in a significant impact to land-based economies in the Project Area. As noted in Section 6.2.1, direct impacts and conversion of 1,353.5 acres of agricultural land to developed and grassland within the fenced area of the solar facility would reduce the amount of agricultural land in the Study Area by four percent. Agricultural production would be allowed to continue in the surrounding areas during construction and operation of the Project.

No areas used for animal husbandry are located within the Project Area; therefore, no impacts to livestock are anticipated.

The revenue lost from removing land from agricultural production will be offset by production from solar energy production and the associated Land Lease and Solar Easement payments to the associated landowners. Areas disturbed during construction will also be repaired and restored to pre-construction contours and characteristics to the extent practicable. This restoration will allow the Project's land surfaces to drain properly, blend with the natural terrain, re-vegetate naturally, and avoid erosion.

Based on discussions with Project landowners, Harmony does not believe drain tile is present in the Project Area. However, Harmony will gather additional information about the existence of drain tile from landowners and other data sources, possibly including, but not limited to, infrared aerial photographs. In the event that damage occurs to drain tile or private ditches as a result of construction activities or operation of the Project, Harmony will work with the affected property owners to repair any damages.

6.10 Soils

Soil characteristics within the study area were assessed using the Soil Survey Geographic (SSURGO) database (Soil Survey Staff 2018). The SSURGO database is a digital version of the original county soil surveys developed by NRCS for use with GIS. It provides the most detailed level of soils information for natural resource planning and management. Soil maps are linked in the SSURGO database to information about the component soils and their properties (USDA NRCS 2018). Table 6-6 lists the soil types located within the Study Area.

Approximately 36 percent of the Study Area is underlain by hydric soils or soils containing hydric inclusions. All of the soils in the Study Area (with the exception of areas mapped as “Water”) have low to moderate susceptibility to erosion by water (i.e., K-factors from 0.1 to 0.4). All of soils in the Study Area are in Wind Erodibility Group 6 or 4L, which correspond to Wind Erodibility Indices of 86 tons/acre/year and 48 tons/acre/year, (USDA NRCS 2018).

Table 6-6: Summary of Soils within Study Area

MAP UNIT SYMBOL	SOIL NAME	ACRES	PERCENT OF STUDY AREA	FARMLAND DESIGNATION	HYDRIC SOIL	K-FACTOR	WIND ERODIBILITY GROUP
I119A	Bearden silty clay loam, 0 to 2 percent slopes	4,198.4	11.4	All areas are prime farmland	No	.28	4L
I201A	Glyndon silt loam, 0 to 2 percent slopes	554.2	1.5	All areas are prime farmland	No	.32	4L
I229A	Fargo silty clay, 0 to 1 percent slopes	2,892.4	7.8	Prime farmland if drained	Yes	.17	4
I231A	Dovray silty clay, 0 to 1 percent slopes	6.3	0.0	Prime farmland if drained	Yes	.20	4
I233A	Fargo silty clay loam, 0 to 1 percent slopes	3,225.0	8.7	Prime farmland if drained	Yes	.28	6
I235A	Fargo silty clay, depressionnal, 0 to 1 percent slopes	352.8	1.0	Prime farmland if drained	Yes	.17	4
I238A	Fargo-Hegne silty clays, 0 to 1 percent slopes	1,933.7	5.2	Prime farmland if drained	Yes	.24	4
I248A	Wahpeton silty clay, 0 to 2 percent slopes, occasionally flooded	10.5	0.0	All areas are prime farmland	No	.17	4
I329A	Fairdale silt loam, 0 to 2 percent slopes, occasionally flooded	44.4	0.1	All areas are prime farmland	No	.28	4L
I371A	Bearden-Kindred silty clay loams, 0 to 2 percent slopes	4,001.9	10.8	All areas are prime farmland	No	.32	4L
I373A	Kindred-Bearden silty clay loams, 0 to 2 percent slopes	8,071.0	21.8	All areas are prime farmland	No	.32	6
I376A	Colvin silty clay loam, 0 to 1 percent slopes	19.0	0.1	Prime farmland if drained	Yes	.37	4L
I383A	Overly silty clay loam, 0 to 2 percent slopes	489.2	1.3	All areas are prime farmland	No	.32	6
I383B	Overly silty clay loam, 2 to 6 percent slopes	321.2	0.9	All areas are prime farmland	No	.32	6
I472A	Perella silty clay loam, 0 to 1 percent slopes	63.4	0.2	Prime farmland if drained	Yes	.32	6
I473A	Hegne-Fargo silty clay loams, 0 to 1 percent slopes	4,684.7	12.7	Prime farmland if drained	Yes	.32	4L
I479B	Fairdale-Fluvaquents, channeled complex, 0 to 6 percent slopes, frequently flooded	146.2	0.4	Not prime farmland	No	.28	4L
I482A	Overly-Bearden silt loams, 0 to 2 percent slopes	1,171.6	3.2	All areas are prime farmland	No	.43	6

Table 6-6: Summary of Soils within Study Area

MAP UNIT SYMBOL	SOIL NAME	ACRES	PERCENT OF STUDY AREA	FARMLAND DESIGNATION	HYDRIC SOIL	K-FACTOR	WIND ERODIBILITY GROUP
I488B	Ortonville silt loam, lacustrine, 2 to 6 percent slopes	712.1	1.9	All areas are prime farmland	No	.32	4L
I490A	Glyndon-Tiffany silt loams, 0 to 2 percent slopes	1,384.6	3.7	Prime farmland if drained	No	.32	4L
I492A	Bearden-Lindaas silty clay loams, 0 to 2 percent slopes	2,591.4	7.0	Prime farmland if drained	No	.32	4L
I601A	Bearden silty clay loam, moderately saline, 0 to 2 percent slopes	107.2	0.3	Not prime farmland	No	.28	4L
IWa	Water	7.3	0.0	Not prime farmland	No	--	--
Study Area Total		36,988.3	100.0				

Source: Soil Survey Staff, Natural Resources Conservation Service (NRCS), U.S. Department of Agriculture (USDA).

Prime farmland is defined as land that has the best combination of physical and chemical characteristics for producing food, feed, fiber, and oilseed crops, and is also available for these uses (the land could be cropland, pasture, woodland, or other lands). Urbanized land and open water cannot be designated as prime farmland. Prime farmland typically contains few or no rocks, is permeable to water and air, is not excessively erodible or saturated with water for long periods and is not subject to frequent or prolonged flooding during the growing season. Soils that do not meet the above criteria may be considered prime farmland if the limiting factor is mitigated (e.g., by draining or irrigating) (USDA NRCS 2018).

The NRCS also recognizes farmlands of statewide importance, which are defined as lands other than prime farmland that are used for production of specific high-value food and fiber crops (e.g., citrus, tree nuts, olives, fruits, and vegetables). Farmlands of statewide importance have the special combination of soil quality, location, growing season, and moisture supply needed to economically produce sustained high quality or high yields of specific crops when treated and managed according to acceptable farming methods. Farmland of statewide importance is similar to prime farmland but with minor shortcomings such as greater slopes or less ability to store soil moisture. The methods for defining and listing farmland of statewide importance are determined by the appropriate State agencies, typically in association with local soil conservation districts or other local agencies.

Table 6-7 lists the soils considered prime farmland and soils of statewide or local importance within the Study Area. Figure 8 depicts the distribution of prime farmland, prime farmland if drained, and not prime farmland within the Study Area.

Table 6-7: Farmland Classifications within the Study Area

Farmland Classification	Area (acres)	Percentage of Study Area
Prime Farmland	19,574.5	52.9
Prime Farmland if Drained	17,153.2	46.4
Farmland of Statewide Importance	--	--
Not Prime Farmland	260.7	0.7
TOTAL	36,988.3	100.0

Source: Soil Survey Staff, NRCS, USDA. Web Soil Survey.

6.10.1 Soils Impacts/Mitigation

The soils that will be impacted by the Project are typically moderately well-drained to somewhat poorly drained and suited for the existing agricultural production. Most of the facility locations are on level to nearly-level topography, which is consistent with the current agricultural production. See Table 6-8 for details on the soil map units that will be impacted by the Project and their associated characteristics.

Table 6-8: Soils Impact Summary

MAP UNIT SYMBOL	SOIL NAME	ACRES OF IMPACT	% OF IMPACT ACRES	FARMLAND DESIGNATION	HYDRIC SOIL	K-FACTOR	WIND ERODIBILITY GROUP
Direct							
I119A	Bearden silty clay loam, 0 to 2 percent slopes	2.5	0.2%	All areas are prime farmland	No	.28	4L
I229A	Fargo silty clay, 0 to 1 percent slopes	4.5	0.3%	Prime farmland if drained	Yes	.17	4
I233A	Fargo silty clay loam, 0 to 1 percent slopes	7.2	0.5%	Prime farmland if drained	Yes	.28	6
I235A	Fargo silty clay, depressionnal, 0 to 1 percent slopes	3.2	0.2%	Prime farmland if drained	Yes	.17	4
I238A	Fargo-Hegne silty clays, 0 to 1 percent slopes	1.3	0.1%	Prime farmland if drained	Yes	.24	4
I371A	Bearden-Kindred silty clay loams, 0 to 2 percent slopes	8.8	0.6%	All areas are prime farmland	No	.32	4L
I373A	Kindred-Bearden silty clay loams, 0 to 2 percent slopes	4.3	0.3%	All areas are prime farmland	No	.32	6
I383A	Overly silty clay loam, 0 to 2 percent slopes	0.2	0.0%	All areas are prime farmland	No	.32	6
I482A	Overly-Bearden silt loams, 0 to 2 percent slopes	9.7	0.7%	All areas are prime farmland	No	.43	6
Direct Subtotal		41.7	2.9%				
Conversion to Grassland							
I119A	Bearden silty clay loam, 0 to 2 percent slopes	99.0	7.3%	All areas are prime farmland	No	.28	4L
I229A	Fargo silty clay, 0 to 1 percent slopes	128.6	9.4%	Prime farmland if drained	Yes	.17	4
I233A	Fargo silty clay loam, 0 to 1 percent slopes	227.5	16.7%	Prime farmland if drained	Yes	.28	6
I235A	Fargo silty clay, depressionnal, 0 to 1 percent slopes	84.8	6.2%	Prime farmland if drained	Yes	.17	4
I238A	Fargo-Hegne silty clays, 0 to 1 percent slopes	70.5	5.2%	Prime farmland if drained	Yes	.24	4
I371A	Bearden-Kindred silty clay loams, 0 to 2 percent slopes	277.8	20.4%	All areas are prime farmland	No	.32	4L
I373A	Kindred-Bearden silty clay loams, 0 to 2 percent slopes	156.0	11.5%	All areas are prime farmland	No	.32	6

Table 6-8: Soils Impact Summary

MAP UNIT SYMBOL	SOIL NAME	ACRES OF IMPACT	% OF IMPACT ACRES	FARMLAND DESIGNATION	HYDRIC SOIL	K-FACTOR	WIND ERODIBILITY GROUP
I383A	Overly silty clay loam, 0 to 2 percent slopes	2.6	0.2%	All areas are prime farmland	No	.32	6
I482A	Overly-Bearden silt loams, 0 to 2 percent slopes	272.5	20.2%	All areas are prime farmland	No	.43	6
Conversion to Grassland Subtotal		1,319.2	97.1%				
Temporary							
I373A	Kindred-Bearden silty clay loams, 0 to 2 percent slopes	1.0	0.1%	All areas are prime farmland	No	.32	6
I482A	Overly-Bearden silt loams, 0 to 2 percent slopes	0.1	0.0%	All areas are prime farmland	No	.43	6
Temporary Subtotal		1.1	0.1%				
Project Total		1,362.0	100.0%				

Source: Soil Survey Staff, Natural Resources Conservation Service, United States Department of Agriculture.

As shown in Table 6-9, all of the soils impacted by the Project are classified as prime farmland soils, or prime farmland if drained; however, it is important to note that the prime farmland designation is independent of current land use (USDA NRCS 2018). The Project will directly impact 41.4 acres of prime farmland or prime farmland if drained that are also identified by USGS GAP as agricultural. In total, the Project will convert 1,353.5 acres of agricultural land designated as prime farmland or prime farmland if drained to grassland and developed area for the life of the Project, which is less than 3.7 percent of the Study Area.

Table 6-9: Farmland Classifications Impacted by the Project¹

Impact Type	Prime Farmland	Prime Farmland if Drained	Total
Direct	25.2	16.2	41.4
Conversion to Grassland	806.2	505.9	1,312.1
Land Use Conversion Subtotal	831.4	522.1	1,353.5
Temporary	0.8	0.0	0.8
Total	832.2	522.1	1,354.3

¹ Impacts to prime farmland exclude areas classified by USGS GAP as developed (see Table 6-3)

Source: Soil Survey Staff, NRCS, USDA.

Impacts to soils will occur during the construction stages of the Project. Construction of each of the facilities may require some amount of grading to provide a level surface for the solar arrays. Because the majority of the facility locations are on relatively level existing agricultural fields, the Project will minimize grading to the extent practicable. Additional soil impacts during construction will come from the installation of the direct-embedded piers that support the structural framework of the solar arrays, and small areas of foundations for the inverters and O&M structures. Details about construction and operation activities for the Project are provided in Sections 5.1 and 5.2, respectively.

Areas of the site to be graded will have topsoil and organic matter stripped and segregated from the subsoil. Topsoil shall have temporary and permanent stabilization measures established in accordance with the Project's storm water pollution prevention plan. Soil replacement and/or amendments may be necessary in limited areas of some of the facilities, especially in hydric soil units near wetlands, or other areas with soil limitations. Internal roads will be constructed of inorganic fill (road aggregate base) to match the surrounding existing ground elevations to allow existing drainage patterns to persist. Once the necessary grading is complete, subsoil will be placed followed by topsoil, blending the grade into existing topography.

Following construction, Harmony will restore disturbed areas to pre-construction conditions to the extent practical. Soil erosion, compaction, and other related disturbance will be minor and short-term, and will be minimized by implementing environmental protection measures. These measures will include BMPs for erosion and sediment control, such as temporary seeding, permanent seeding, mulching, filter strips, erosion blankets, and sod stabilization.

Additionally, recent research on the environmental impacts of solar farms indicates that there could be some net benefits to soil resources over the lifecycle of the Project. Writing in Cleantechica,

one of the world's top cleantech-focused news sites, engineer Jeff Briberg highlights the utility and specific benefits of using native plants on solar sites (Briberg 2016).

“[Compared to row crops,] storm water runoff is reduced 23 percent for the 2-year storm (2.9 inches of rain) and 8 percent for the 100-year storm (7.8 inches of rain).

Further, we expect a mix of prairie plants to provide superior hydrologic performance compared to monocrop turf-grasses that are common on solar sites in some areas of the country. In 2008, the U.S. Geological Survey completed a five-year storm water study in cooperation with a consortium of 19 cities and towns in the area of Madison, Wisconsin that revealed “striking differences between turf and prairie vegetation.” The study found “prairie vegetation had greater median infiltration rates than those with turf grass,” and roots in the prairie vegetation plot were “found to a depth of 4.7 feet compared with 0.46 feet in the turf.”

In addition to superior storm water management, native plants improve the soil with organic matter over the 20 to 30-year life the project, allowing microorganisms and soil fauna to recover after years of intensive compaction, pesticide and fertilizer application. And, over time, native plants out-compete weeds allowing ground cover to be maintained with just a single annual mow, reducing operating costs.”

With the proper implementation of environmental protection measures intended to prevent, minimize, and/or reclaim soil erosion, compaction, and spill effects, no unmitigated loss of highly productive soil will result from the Project. Additionally, Harmony plans to use a seed mix that is designed to promote pollinator habitat. Seed mixes are discussed in more detail in Section 6.14.

6.11 Geologic and Groundwater Resources

Surface geology within the Study Area is considered part of the Coleharbor Formation, which consists of lake sediment (silt and clay) and river and beach sediment (sand and gravel) (Bluemle 1977). The major geomorphologic feature making up the eastern three-fourths of Cass County is the Red River Valley of the North. This valley is a lake plain formed by glacier melt waters of a massive glacial ice lobe which occupied the area some 10,000 to 15,000 years ago.

The West Fargo Aquifer System is located on the eastern edge of the Study Area (Figure 9). According to North Dakota State Water Commission data, there are nine domestic or stock wells within the Study Area.

A review of U.S. Geological Survey (USGS) topographic maps revealed no sand, gravel, or other mines within the Study Area. The Study Area is not located in an area with economic reserves of hydrocarbons, as supported by information from the North Dakota Industrial Commission Department of Mineral Resources, Oil and Gas Division (North Dakota Division of Oil and Gas 2018), including well locations and mapped oil and gas fields.

6.11.1 Geologic and Groundwater Impacts/Mitigation

Impacts of the proposed Project to available geologic resources are likely to be limited. Due to the thickness of surficial materials (approximately 200 feet [Anderson 2011]), excavation or blasting of bedrock is extremely unlikely.

Impacts to groundwater resources, including aquifers, are not anticipated as water supply needs will be quite limited. It is probable that operations and maintenance water requirements will be satisfied with a single domestic-sized water well. Based on the small amount of increased impervious surface area that will be created by Project components (41.7 acres), the Project will likely have minimal impacts on regional groundwater recharge. The foundations of the racking system will likely be a driven steel pier and will likely not require concrete, although some concrete foundations may be required. Geotechnical soil testing will determine final installation process. Similarly, the exterior security fence may require concrete foundations in some locations.

In addition, the Project is located at least 1,085 feet from the nearest occupied residence, thereby minimizing the risk of impacts on private wells in the area, which are assumed to be located in proximity to the occupied residences they serve. Construction of the Project facilities is not likely to require subsurface blasting; therefore, disturbances to groundwater flow from newly fractured bedrock are not anticipated.

Impacts to geologic resources are not anticipated and mitigation is not expected to be necessary. Project facilities are not likely to affect the use of existing water wells because the facilities will not be sited within 1,085 of occupied residences. Any dewatering required during construction will be discharged to the surrounding surface, thereby allowing it to infiltrate back into the ground to minimize potential impacts.

6.12 Surface Water and Floodplain Resources

The Study Area is located in the Devils Lake-Sheyenne River Watershed Basin, which is part of the Hudson Bay drainage. Cass County has 32 lakes, averaging 42 acres in size, and found mostly in the west and southwest portions of the county. These lakes and reservoirs provide flood protection, irrigation, and recreation. There are no lakes within the Study Area. There is one stream within the Project Area, the Lower Branch Rush River. This stream intersects the Project Area in two locations: first, at its narrowest point along 160th Avenue in a narrow corridor connecting solar arrays and second, approximately 1,125 feet of this stream crosses the Project Area in the southeast quarter of Section 10 in T140N R51W (Figure 9 and Appendix F). In both cases, the stream is within the Project Area, but outside of the security fence. The remaining sources of surface water are wetlands, which are valuable for surface and subsurface water storage, nutrient cycling, retention of sedimentation, and plant and animal habitats. Wetlands are described further in Section 6.13.

There are no flood rating maps compiled by the Federal Emergency Management Agency for the Study Area due to its rural location. Additionally, the NDSWC stated in a letter that there are no permits required relative to the National Flood Insurance Program (FIRM) based on the current effective FIRM and state minimum standards (Appendix C). Based on a preliminary hydrology study conducted for the Project, as proposed in this Application, the Project avoids areas of higher

water depths and velocities and is suitable for development of a solar facility (Westwood Professional Services 2016).

6.12.1 Surface Water and Floodplain Impacts/Mitigation

Harmony submitted the wetland delineation report to the U.S. Army Corps of Engineers (USACE), Omaha District, North Dakota Regulatory Branch for a Jurisdictional Determination (JD) of Waters of the U.S. in the Project Area. In a letter dated January 12, 2017, the USACE provided a JD for the Lower Branch Rush River; the agency did not identify any other wetlands or waterbodies as Waters of the U.S (Appendix C). As noted above, the Project design of most facilities avoids impacts to this waterbody. An electrical cable connecting the southern-most solar field to the other two will cross the Lower Branch Rush River (Figure 2). This cable will either be installed via horizontal directional drill or trenching. Due to the small impact area around this waterbody (i.e., less than 0.5 acre), the waterbody crossing will be permitted under a Section 404 USACE Nationwide Permit (NWP). As such, NWP specific General and/or Regional Conditions prescribed for projects in North Dakota as set forth by the USACE and other applicable BMPs will be used during construction and operation of the Project to protect topsoil, minimize soil erosion, and protect adjacent wetland and waterbody resources from direct and indirect impacts. Practices may include containing excavated material, use of silt fences, protecting exposed soil, stabilizing restored material, and re-vegetating disturbed areas with native species.

The NDSWC provided contact information should surface water or groundwater be diverted for construction. Additionally, the Office of the State Engineer (OSE) reviewed the Project and determined that the Project will be constructed in the vicinity of surface waters. As such, OSE requested to be notified regarding potential project impacts, if any, to water resources, as these impacts may require a drainage permit or a construction permit. Harmony is determining the construction method for the installation of the collection line near the Lower Branch Rush River and will coordinate with NDSWC and the OSE regarding this potential impact.

The Project will not impact known floodplain areas; therefore, no mitigation measures are proposed.

6.13 Wetlands

The potential for wetlands within the Study Area was identified by reviewing desktop National Wetlands Inventory (NWI) data followed by formal wetland delineations within the Project Area. Desktop analysis of NWI data identified 256.6 acres of the Study Area classified as NWI wetlands, most of which are associated with drainageways (Table 6-10 and Figure 9). Wetlands characterized as riverine are generally associated with the Rush River and Lower Branch Rush River.

Table 6-10: NWI Wetlands within the Study Area

NWI Wetland Type	Acres
Freshwater Emergent Wetland	137.4
Freshwater Forested/Shrub Wetland	6.1
Riverine	113.0
Total	256.6

On-site wetland delineations within the Project Area confirmed absence of NWI-mapped wetlands (see Appendix F).

6.13.1 Wetlands Impacts/Mitigation

The Project will not impact wetland areas; as such, no mitigation measures are proposed.

6.14 Vegetation

The Study Area is located in the Northern Glaciated Plains ecoregion. Soil and weather conditions in this region promote a transition zone between short and tallgrass prairie species. Although historically the ecoregion was dominated by grasslands, it has been primarily converted to farmland. As discussed in Section 6.2, much of the land use in the Study Area is agricultural (USGS 2011). Based on USDA National Agriculture Statistics Service data (2017), soybeans, corn, spring wheat, and sugarbeets made up 93 percent of the vegetative cover in the Study Area. There were no noxious or invasive species observed in the Project Area during wetland delineations; vegetative cover in ditches was predominantly smooth brome. Similarly, no trees or shrubs are present in the Project Area (Appendix F).

6.14.1 Vegetation Impacts/Mitigation

As discussed in Section 6.2.1, the Project will impact 1,353.5 acres of agricultural land, 41.4 acres of which will be converted to impervious surfaces. The other 1,312.1 acres of agricultural land will be revegetated with a pollinator friendly seed mix. Typically, a solar site has a shorter prairie mix within the panel footprint, taller prairie plantings in the open space between the fence and array, and a wet seed mix for any wetlands or areas anticipated to hold water. The mixes are designed to be native and are developed with prairie specialists to design a mix that will achieve Harmony's goals for operating the solar facility, promote pollinator habitat, establish stable ground cover successfully, reduce erosion, reduce runoff, and improve infiltration.

Harmony has developed two sets of seed mixes for this Project that each consist of a short, tall, and wet seed mix. One set reflects a management method of traditional mowing, the other reflects a management method of utilizing sheep as grazers. The main difference between the mowing and grazing is that the grazers will eat all the legumes first, so legumes are cut from the grazing mix and replaced with other species. Harmony's maintenance method has yet to be determined, and, as such both are included in the Vegetation Management Plan (Appendix G). Harmony consulted with the Cass County Soil Conservation District on the seed mixes; the local agency indicated both mixes would grow well in the area (Appendix C).

6.15 Wildlife

Avian Species

The Study Area is located on the eastern edge of the Central Flyway, one of the primary north-south migration routes between migratory bird nesting and wintering habitat migratory bird routes. The Study Area is also located within the Prairie Potholes Bird Conservation Region (BCR) (USFWS 2008). The USFWS identified 27 species of birds within the Prairie Potholes BCR as Birds of Conservation Concern (BCC); BCC are avian species that represent the agency's highest conservation priorities. The BCC in the Prairie Potholes BCR include the bald eagle (*Haliaeetus leucocephalus*), upland sandpiper (*Bartramia longicauda*), Sprague's pipit (*Anthus spragueii*), grasshopper sparrow (*Ammodramus savannarum*), chestnut-collared longspur (*Calcarius ornatus*), and dickcissel (*Spiza americana*) (USFWS 2008).

Migratory birds are federally protected under the Migratory Bird Treaty Act (MBTA), and bald eagles are protected under the MBTA and Bald and Golden Eagle Protection Act (BGEPA) (USFWS 2007, 2017). The MBTA protects migratory birds and most resident birds that are native to the U.S. from impacts and take. BGEPA protects and conserves bald eagles and golden eagles (*Aquila chrysaetos*) from intentional take of an individual bird, chick, egg, or nest, including alternate and inactive nests (USFWS 2007). Unlike the MBTA, BGEPA prohibits disturbance that may lead to biologically significant impacts, such as interference with feeding, sheltering, roosting, and breeding or abandonment of a nest (USFWS 2007).

Land uses in the Study Area are primarily agricultural (95.5 percent), with some developed land (4.0 percent) and small amounts of forested land (0.4 percent), open land (<0.1 percent), and open water (<0.1 percent). Because of the small amount of forested land in the Study Area, few migratory bird species that use trees or forested areas as habitat will be present, such as bald eagle, black-billed cuckoo (*Coccyzus erythrophthalmus*), short-eared owl (*Asio flammeus*), and red-headed woodpecker (*Melanerpes erythrocephalus*). Similarly, because of the small amount of open water and absence of wetlands in the Study Area, no wetland- or water-dependent birds would be present, including waterfowl and waterbirds. Species of migratory birds associated with grassland would also be limited or absent. Overall, few if any BCC are likely to use the Study Area as habitat.

The USFWS is also concerned about avian species that are at risk from habitat fragmentation. Species of habitat fragmentation concern are impacted when larger areas of habitat are divided into smaller areas with concomitant reductions in habitat connectivity (USFWS 2015a). At present, the Study Area is highly fragmented given that greater than 99 percent is used for cropland or is developed. If species of habitat fragmentation concern are present in the Study Area, they have adapted to the fragmentation and current land uses.

Other Wildlife Species

In addition to birds, other groups of wildlife that may occur in the Study Area include mammals, reptiles, amphibians, fish, and insects. Mammals that may be present include white-tailed deer (*Odocoileus virginianus*), Richardson's ground squirrel (*Urocitellus richardsoni*), red fox (*Vulpes vulpes*), raccoon (*Procyon lotor*), and coyote (*Canis latrans*) (NDGFD 2016a). Reptiles and

amphibians that may occur in the Study Area are plains spadefoot (*Spea bombifrons*), Canadian toad (*Anaxyrus hemiophrys*), red-bellied snake (*Storeria occipitomaculata*), plains gartersnake (*Thamnophis radix*), and common gartersnake (*Thamnophis sirtalis*) (Johnson 2016). Given the limited open water in the Study Area, few if any fish species are likely present. Some pollinator insects may be present in limited numbers in the Study Area including native bees, butterflies, and moths.

6.15.1 Wildlife Impacts/Mitigation

Given that that Project Area is currently used as cropland, occurrence of wildlife within the Project Area is likely low. As a result, impacts on wildlife are expected to be minor and insignificant, and construction and restoration of the Project Area may result in wildlife benefits. Common species of wildlife adapted to agricultural land use may be present in the Project Area such as white-tailed deer, turkey, ring-necked pheasant, passerines, rodents, snakes, toads, and insects. During construction, highly mobile species of wildlife including deer, birds, and snakes are expected to divert to areas surrounding the Project. Burrowing animals may be temporarily displaced. Less mobile species and ground nests of birds, eggs, and chicks may be impacted; however, given that the Project Area is predominantly cropland, these impacts may have occurred regardless of the Project. Overall, construction of the Project is expected to have minimal impacts on individuals of common wildlife species, and no impact on populations of these species. During operations, any potential impacts on wildlife are also expected to be minimal and insignificant. These impacts may be related to vehicle traffic and parking or mowing (if that management strategy is used). Although some individuals of common wildlife species may be impacted, no impacts would occur at the population-level, and no species-specific mitigation is proposed.

After construction and during operation, the Project may provide more wildlife habitat than the current land use provides. In areas of the Project where there are land-use conversion impacts and temporary impacts, Harmony will restore with a pollinator friendly vegetation mix that may provide habitat for wildlife, including grassland birds, rodents, reptiles, and insects. In sum, although 41.7 acres within the Project Area would have permanent facilities and would not serve as wildlife habitat during operations, 1,319.2 acres with land-use conversion impacts would be restored as grassland, thereby potentially benefitting and increasing the overall populations of wildlife species in the area, including small mammals, reptiles, and pollinator insects.

6.16 Rare and Unique Natural Resources

Federal Listed Species

Species that are listed as threatened or endangered under the federal Endangered Species Act (ESA) that may occur in Cass County are the whooping crane (*Grus americana*), northern long-eared bat (NLEB) (*Myotis septentrionalis*), and gray wolf (*Canis lupus*). There is no federally designated critical habitat in Cass County (USFWS 2018a).

The whooping crane is federally endangered species. It is the tallest bird in North America at nearly 5 feet tall. The Aransas-Wood Buffalo Population of whooping cranes migrates through North Dakota in the spring and fall. During migration, whooping cranes typically roost overnight in wetlands and forage in agricultural fields during the day (CWS and USFWS 2007). The Study

Area is primarily cropland and as such may serve as foraging habitat for whooping cranes during migration. However, the Study Area is about 60 miles east of the corridor where 95 percent of whooping cranes have been documented (USFWS 2010). Whooping cranes have been recorded once in Cass County in 1976; the sighting was approximately 18 miles southwest of the Study Area. Overall, there is a low likelihood of whooping cranes occurring in the Study Area.

The NLEB is listed as threatened under the federal ESA. It is medium-sized bat species that occurs across the eastern and central U.S. (Caceres and Barclay 2000). The annual life history of the NLEB includes an inactive period when the species is hibernating and an active period when the species forages, raises its young, and breeds. Hibernation generally occurs in caves and mines between October 1 and April 1 (USFWS 2015b 2015c). In April, the species emerges from its hibernacula and moves to summer habitat. Adult females form breeding or maternity colonies that are variable in size, ranging from a few individuals to as many as 60 adults (Caceres and Barclay 2000, WDNR 2015). During the summer, the species roosts in live and dead trees in cavities and crevices and under bark (Timpone et al. 2010). The NLEB forages primarily in forested areas (USFWS 2015c). The Study Area is primarily agricultural lands with small amounts of developed, open lands, and open water. Thus, the likelihood of NLEB occurring within the Study Area is low.

The gray wolf is a federally endangered species in North Dakota. It is the largest wild dog in North America (NDGFD 2016b). Gray wolves can be found in a variety of habitats including grassland, shrubland, and woodland habitats across their range (NDGFD 2016b). In North Dakota, the gray wolf is part of the Western Great Lakes population (USFWS 2015d). The species does not have an established breeding population in North Dakota (NDGFD 2016b). Gray wolf sightings are sporadic, and individuals within North Dakota have likely dispersed from adjacent states and provinces (Licht and Fritts 1994, USFWS 2006). Because of the rarity of the species within the state, the likelihood of gray wolf being present in the study area is very low.

State Species of Conservation Priority

At the state level, North Dakota has identified 115 Species of Conservation Priority that are the focus of its Wildlife Action Plan, including 47 birds, 2 amphibians, 9 reptiles, 21 mammals, 22 fish, 10 freshwater mussels, and 4 insects (NDGFD 2015). Species of Conservation Priority are categorized in three different levels according to each species' conservation need. The North Dakota Game and Fish Department (NDGFD) focuses its efforts on conserving Species of Conservation Priority, but the state does not have prohibitions or require take permits associated with these species. Of the three federally listed species discussed above, the NLEB is a Level I Species of Conservation Priority, the whooping crane is a Level III Species of Conservation Priority, and the gray wolf is not identified as a Species of Conservation Priority in North Dakota (NDGFD 2016c).

The NDGFD conducted a review of species of concern and significant ecological communities within one mile of the Project in April 2016. Based on the review, there were no documented occurrences of species of concern or significant ecological communities within this area (Appendix C).

6.16.1 Rare and Unique Natural Resources Impacts/Mitigation

Harmony requested the USFWS and NDGFD's review of the Project for potential impacts on species under the agencies' jurisdiction. In a letter dated October 31, 2017, the USFWS indicated that the agency had reviewed the Project and had no objection (Appendix C). The NDGFD indicated that the Project did not affect or overlap the resources that the agency managed; the NDGFD recommended that Harmony revegetate impacted areas with species native to the Project Area. Neither agency requested surveys of the species under their jurisdictions, including federally listed species and North Dakota Species of Conservation Priority.

The corridor where 95 percent of whooping cranes have been sighted is about 60 miles west of the Project and only one whooping crane has been documented in Cass County. Thus, the likelihood of a migrating whooping crane occurring within the Project is very low. If whooping cranes entered the Project Area, Project construction and operations would be expected to divert individuals to neighboring agricultural fields; no impacts to individuals would be expected due to the construction and operation of the Project. The sole land-use within the Project is cropland. No potential wetland roosting habitat would be impacted. In general, whooping cranes may use cropland for foraging, but the areas surrounding the Project are also primarily agricultural lands and thus no measurable impact on availability of foraging habitat is expected. Overall, no impacts on whooping crane are anticipated, and no species-specific mitigation is proposed for this species.

The likelihood of NLEB occurring in the Project is very low given the absence of trees and documented hibernaculum and current land-use. The USFWS issued a 4(d) rule for the federally threatened NLEB that defines the species-specific prohibitions under the federal ESA (USFWS 2016). The Project Area is located within the current White-Nose Syndrome Zone (April 30, 2018) (USFWS 2018b). Under the 4(d) rule, incidental take within the White-Nose Syndrome Zone is not prohibited if Project activities would not occur within a hibernaculum, would not alter a hibernaculum's entrance or environment, and would not involve tree removal (USFWS 2018c). Thus, for this Project, no prohibited incidental take is expected. Overall, no impacts on the NLEB are anticipated, and no species-specific mitigation is proposed.

The likelihood of gray wolf occurring within the Project is very low. Gray wolves are rare in North Dakota, and there are no breeding populations. The current land use of cropland is also not suitable for the species. If a gray wolf entered the Project Area, no impacts to individuals would be expected due to the construction and operation of the Project; instead, Project construction and operations would be expected to divert individuals to the surrounding areas. In sum, no impacts on the gray wolf are anticipated, and no species-specific mitigation is proposed.

The likelihood of North Dakota Species of Conservation Priority occurring within the Project is also low. According to the NDGFD's review of the North Dakota Natural Heritage biological conservation database in April 2016, there are no species of concern within one mile of the Project. In addition, current land use within the Project is agriculture. No impacts on North Dakota Species of Conservation Priority are anticipated, and no species-specific mitigation is proposed. The Project may result in additional areas of grassland for Species of Conservation Priority in areas where there are land-use conversion impacts (1,319.2 acres). Harmony will restore these areas with a pollinator friendly seed mix that may provide habitat for Species of Conservation Priority.

6.17 Summary of Impacts

Table 6-11 provides a detailed summary of the impacts discussed in Section 6.0 and mitigation that Harmony will implement to address these impacts.

Table 6-11: Summary of Impacts

Resource	Potential Impact	Proposed Mitigation
Demographics	Profits to landowners from part ownership in the Project may increase per capita income within the Project Area. No long-term changes to demographics are anticipated	No mitigation is proposed.
Land Use, Ownership, and Management	During the life of the Project, approximately 1,360.9 acres would be converted to a renewable alternative energy source.	No mitigation is proposed for the land use conversion; however, lease payments would be made to landowners for placement of solar facilities.
Public Services	There will be an increase in traffic volume during construction but is not expected to affect traffic function. A glare study indicated there will be no glare at a nearby unregistered private landing strip.	No mitigation is proposed.
Human Health and Safety	No adverse impacts are anticipated	Project facilities are set back 1,085 feet from the nearest residence, and a buffer will be installed. This residence is owned by a Project participant.
Sound	There will be increased noise during construction. Based on the inverter options under consideration and the distance to the nearest residence (1,085 feet), noise levels from the Project equipment are no expected to be discernible from background noise levels at homes near the Project.	During construction, Harmony will limit construction to daylight hours. No mitigation is proposed during operation.
Visual	The Project will have visual impact due to the flat terrain and lack of existing visual screen.	Harmony has worked with an adjacent residence to design the Project with a buffer between the residence and solar facility.
Cultural and Archaeological Resources	No previously recorded archaeological or historic sites, or historic architectural resources, were identified during the Class I and III inventories of the Project Area.	Harmony will prepare an Unanticipated Discoveries Plan.

Table 6-11: Summary of Impacts

Resource	Potential Impact	Proposed Mitigation
Recreational Resources	There are no designated recreation areas in the Project Area. The Project may be visible from snowmobile trail 2 miles south of the Project.	No mitigation is proposed.
Land Based Economics	Direct impacts to 41.4 acres of agricultural land and conversion of an additional 1,312.1 acres from agricultural land to solar facilities (1,353.5 acres total).	Economic loss to producers due to land conversion is anticipated to be negligible in comparison to lease payments for solar facilities.
Soils	The Project will directly impact 41.4 acres of prime farmland or prime farmland if drained that are also classified by USGS GAP as agricultural and will result in a total of 1,353.5 acres of agricultural land designated as prime farmland or prime farmland if drained being converted to a different use during the life of the Project. Land use conversion will not constitute a loss of prime farmland as the physical and chemical characteristics that make the land suitable for classification as prime farmland will remain the same. Construction activities may cause compaction, grading, and soil erosion.	The Project will use a pollinator friendly seed mix, which may have more beneficial properties to soil characteristics compared to row crops. Harmony will implement BMPs for compaction and soil erosion, as well as implement a SWPPP.
Geologic and Groundwater Resources	No adverse impacts anticipated.	No mitigation is proposed.
Surface Water and Floodplain Resources	An electrical cable connecting the southern-most solar field to the other two will cross the Lower Branch Rush River, a jurisdictional waterbody.	This cable will either be installed via horizontal directional drill or trenching. Due to the small impact area around this waterbody (i.e., less than 0.5 acre), the waterbody crossing will be permitted under a Section 404 USACE Nationwide Permit.
Wetlands	No adverse impacts anticipated.	A wetland delineation confirmed absence of mapped wetlands in the Project Area.

Table 6-11: Summary of Impacts

Resource	Potential Impact	Proposed Mitigation
Vegetation	The Project will impact 1,353.5 acres of agricultural land, 41.4 acres of which will be converted to impervious surfaces. The other 1,312.1 acres of agricultural land will be revegetated with a pollinator friendly seed mix.	In coordination with prairie specialists and the Cass County Soil and Water Conservation District, Harmony has developed two pollinator friendly seed mixes to be used at the Project. The mixes differ in the management strategy to be employed: either mechanical or grazing, which will be determined prior to operation.
Wildlife	Given that that Project Area is currently used as cropland, occurrence of wildlife within the Project Area is likely low. As a result, impacts on wildlife are expected to be minor and insignificant, and construction and restoration of the Project Area may result in wildlife benefits.	After construction and during operation, the Project may provide more wildlife habitat than the current land use provides. In areas of the Project where there are land-use conversion impacts and temporary impacts, Harmony will restore with a pollinator friendly seed mix that may provide habitat for wildlife, including grassland birds, rodents, reptiles, and insects.
Rare and Unique Natural Resources	The Project is unlikely to impact federally listed species in Cass County due to lack of habitat. A search of the Natural Heritage Database identified no records of species of concern within one mile of the Project.	No mitigation is proposed.

7.0 IDENTIFICATION OF POTENTIAL PERMITS/APPROVALS

Table 7-1: Potential Permits/Approvals

Agency	Permit	Applicability	Permit Status and Timing
US Army Corp of Engineers	Section 404 Permit for wetland impacts.	Dredging or filling jurisdictional waters of the United States	May or may not be required dependent upon construction methodology for electrical cable installation crossing Lower Branch Rush River
U.S. Environmental Protection Agency	Spill Prevention, Control, and Countermeasures Plan (SPCC Plan)	Required if any facility associated with the Project (O&M or substation) has oil storage of more than 1,320 gallons	To be obtained prior to construction, if necessary
North Dakota Public Service Commission	Certificate of Site Compatibility	Construction of energy conversion facility	To be obtained prior to construction
North Dakota Parks and Recreation Department	Review and Coordination	Provide results of Natural Heritage Database search within one mile of the Project	Complete. No records within one mile of the Project
North Dakota Dept. of Health	Section 401 Certification	Required for filling in jurisdictional waters of the United States	An Individual Section 401 certification will not be required, as the Project will either not impact jurisdictional waters of the U.S. or will qualify for a Nationwide Permit from the USACE, dependent upon construction methodology for electrical cable installation crossing Lower Branch Rush River
	NDPDES General Permit (includes SWPPP)	For stormwater discharges from construction activities with disturbances greater than one acre	To be obtained prior to construction
	Potable/Wastewater Permit	Required for installation of water or wastewater systems	To be obtained prior to construction of low-volume well at O&M Facility
State Historic Preservation Office	Review and Coordination	Provide concurrence on Class I and Class III inventory	Complete
North Dakota State Water Commission	Drain Permit	Required for any pond, slough, lake or sheetwater drainage for areas with a watershed of 80 acres or more	Not anticipated at this time

Table 7-1: Potential Permits/Approvals

Agency	Permit	Applicability	Permit Status and Timing
	Water Permit	Required when withdrawn water is greater than 12.5 acre-feet	Not anticipated at this time
Cass County	Floodplain Development Permit	Required for development within a floodplain	Not applicable. FEMA has not designated floodplains in the Project Area
Harmony Township	Township Road Access Permit	Required for access from township roads	Harmony will coordinate with the Township to acquire this permit prior to construction
	Conditional Use Permit	Required for construction within Harmony Township	Permit received August 27, 2017
	Building Permit	Required for construction within Harmony Township	Prior to construction
Rush River Water Resource District	Utility Permit	Required for utilities under Lower Branch Rush River	Prior to construction

8.0 FACTORS CONSIDERED

The Siting Act (see NDCC Section 49-22-09) lists the following factors to guide the Commission in assessing and designating the site for the proposed facility.

8.1 Public Health and Welfare, Natural Resources, and the Environment

Potential Project impacts on public health and welfare, natural resources, and the environment are discussed throughout this Application. In addition, Section 6.17 provides a summary of impacts and proposed mitigation measures to minimize these impacts. As discussed in this Application, the Project has been designed to avoid and/or minimize potential impacts to public health and welfare, natural resources, and the environment.

8.2 Minimizing Adverse Environmental Effects

Harmony will use the best available technologies. Current solar panel technologies optimize solar and land resources, while minimizing adverse environmental effects. Avoidance and minimization measures associated with various resources are identified in their corresponding sections within Section 6.0.

8.3 Potential for Beneficial Uses of Waste Energy

Since solar energy does not create waste energy, there would be no use of waste energy associated with this Project.

8.4 Unavoidable Adverse Environmental Effects

Unavoidable adverse environmental effects are described for each resource area in Section 6.0. Unavoidable direct ground disturbance will include conversion of land to a renewable energy generation resource for the life of the Project. The direct impacts will total 41.7 acres from conversion of agricultural land and developed land to access roads, inverters, and the Project substation and O&M facility. The Project will convert an additional 1,319.2 acres of agricultural and developed land by revegetating with a pollinator friendly seed mix that promotes pollinator habitat and may create habitat for other wildlife. For the residence closest to the Project, Harmony has minimized the impact through shifting the Project Area boundary to create distance from this residence in coordination with the landowner.

Harmony selected this site to minimize unavoidable environmental impacts and will implement appropriate minimization and mitigation measures throughout Project development.

8.5 Alternatives to the Proposed Site

After considering alternative sites for wind energy project development, Harmony chose the proposed site for the Project because of its multitude of favorable site characteristics, including but not limited to a largely supportive landowner population, a feasible electrical interconnection,

and minimal impacts to the natural environment when compared with other potential projects as the Project is located on previously disturbed agricultural land.

8.6 Irreversible and Irretrievable Commitment of Natural Resources

With a renewable energy project like the one being proposed herein, there are relatively few irreversible and irretrievable commitments of natural resources. In the case of the Project, construction-related activities are expected to be the primary source of the irreversible and irretrievable commitment of natural resources. Aggregate resources, concrete, steel, and hydrocarbon fuel will be used as construction materials and resources. The Project's access roads will consist of aggregate (i.e. gravel) and Harmony will use concrete for facility foundations, including inverter foundations. Harmony anticipates recovering some portion of the aggregate used for the roads and foundation but not all of it. The piles and racking equipment are constructed primarily of steel and aluminum. A majority of the steel used will be recoverable. Construction machinery and delivery vehicles will use hydrocarbon fuels. Once expended, these hydrocarbons will not be recoverable.

8.7 Direct and Indirect Economic Impacts

The direct economic impacts of the operation of the Project are significant, as detailed in Section 3.6. Landowners will be directly compensated for the use of their land and they have chosen to take the opportunity to participate in Harmony, in part, because of the positive economic impact it provides to them their local community. Shorter-term economic benefits during construction include wages and salaries paid to local hires, which will contribute to the total personal income of the region.

There are also significant indirect benefits related to the supplies and services required for the construction and operation of a large-scale \$250 million facility in this area. Additional personal income will be generated for residents in the county and the state by circulation and recirculation of dollars paid out by Harmony as business expenditures and state and local taxes. Expenditures will be made for equipment, energy, fuel, operating supplies, and other products and services, which will benefit businesses in the county and the state.

The additional tax revenue and diversified income to landowners will have a positive impact on the local economy.

The development of solar energy in this region can also play an important role in diversifying and strengthening the economic base of eastern North Dakota. Additionally, continuing to establish North Dakota as a producer of renewable energy sources may spur the development of related businesses in the area, which will contribute to the economic growth in the region.

8.8 Existing Development Plans of the State, Local Government and Private Entities at or in the Vicinity of the Site

No conflicts are anticipated with existing state and local government or private entities' development plans. On various occasions, Harmony met with Cass County and North Dakota

officials regarding the Project. No issues related to existing development plans were raised at those meetings.

8.9 Effect of Site on Cultural Resources

As discussed in Section 6.7, Harmony completed a Class I literature search of known cultural and archaeological resources within the Project Area and a Class III inventory of the Project Area; no cultural resources were identified. Harmony will prepare an Unanticipated Discoveries Plan, which details a process for prompt communication and action regarding the discovery of previously unknown cultural resources or human remains, should they be encountered during construction. See Section 6.7 for further discussion of cultural resource survey efforts and SHPO coordination.

8.10 Effect of Site on Biological Resources

The USFWS and NDGFP have indicated they do not have any objection to the Project and there are no known records of rare species in the Project vicinity. The Project will not impact wetlands and may have a temporary impact to the Lower Branch Rush River, depending on the construction method for installing a collection line. Harmony will implement BMPs to minimize impacts at this stream crossing.

9.0 AGENCY COMMENTS

On September 25, 2017, Harmony distributed a request for comment letter to 33 federal and state agencies. Additionally, Harmony has coordinated with various local agencies including Cass County Commissioners, the Cass County Weed Control Officer, Cass County Soil Conservation District, Harmony Township, and the Greater Fargo Moorhead Economic Development Corporation. To date, Harmony has received responses from nine agencies. These comments, which are summarized below, have been referenced and incorporated where appropriate in this Application. Refer to Appendix C for the request for comment letter, mailing list, and responses.

9.1 U.S. Department of Defense – Army Corps of Engineers, North Dakota Regulatory Office

In a letter dated October 12, 2017, the USACE noted that if the Project will require the discharge of dredge or fill materials into waters of the U.S. (Section 404 Clean Water Act), a Section 404 permit will be required. The Agency provided information on NWP 12, Utility Line Activities as well as information on a Standard or Individual Permit if the Project required permitting and could not be authorized by a NWP.

The USACE also provided a Jurisdictional Determination on Waters of the US in a letter dated January 12, 2017 (this date is a typo and should read January 12, 2018).

9.2 US Fish & Wildlife Service

The USFWS North Dakota Ecological Services Office provided the original request for comment letter with a stamp reading “This constitutes a report of the Department of the Interior prepared in accordance with the Fish and Wildlife Coordination Act (16 U.S.C. 661 et seq). We have reviewed and have NO OBJECTION to this project.” The stamp is signed by the North Dakota state supervisor and dated 10/30/2017.

9.3 North Dakota Department of Health

In a letter dated October 11, 2017, NDDH stated that they believed the environmental impacts from the proposed project will be minor and can be controlled by proper construction methods. These methods included minimizing fugitive dust emissions, adverse effects to waterbodies, and obtaining a NDPDES permit. Included with the letter were NDDH’s construction and environmental disturbance requirement. NDDH further stated that it owns no land in or adjacent to the Project Area and that the Project is consistent with the State Implementation Plan for the Control of Air Pollution for the State of North Dakota.

The Project will utilize water from local sources for dust control during construction. Construction equipment will be kept in good working order, including mufflers as recommended by the equipment manufacturer. If oil storage in excess of 1,320 gallons of petroleum products is located on site, Harmony will complete a SPCC Plan. No wetlands are present within the Project Area, and only one intermittent stream may be temporarily impacted during Project construction. The Project will comply with EPA regulations regarding storm water runoff, including the creation of

a SWPPP. Harmony will also comply with the requirements of the NDDH's construction and environmental disturbance requirements.

9.4 North Dakota Department of Transportation

In a letter dated October 17, 2017, NDDOT indicated the Project should have no adverse impact on the North Dakota Department of Transportation highways. The letter further stated that if work was required on highway right-of-way, appropriate permits and risk management documents will need to be obtained from the District Engineer.

The Project will not impact highway right-of-way.

9.5 North Dakota Parks and Recreation Department

In a letter dated August 29, 2016, North Dakota Parks and Recreation Department indicated the project as defined does not affect state park lands or Land and Water Conservation Fun recreation projects they coordinate. Additionally, the agency noted that there are no Natural Heritage records of any plant or animal species of concern or other significant ecological communities within or adjacent to the Project Area. North Dakota Parks and Recreation also recommend any impacted areas be revegetated with a species native to the Project Area.

Harmony has developed seed mixes that promote pollinator habitat.

9.6 North Dakota State Water Commission

In an October 23, 2017 letter, the North Dakota State Water Commission indicated the Project will not require a National Flood Insurance Program permit or a conditional or temporary permit for water appropriation. The NDSWC provided contact information should surface water or groundwater be diverted for construction. Additionally, the OSE reviewed the Project and determined that the Project will be constructed in the vicinity of surface waters. As such, OSE requested to be notified regarding potential project impacts, if any, to water resources, as these impacts may require a drainage permit or a construction permit.

Harmony is determining the construction method for the installation of the collection line near the Lower Branch Rush River and will coordinate with NDSWC and the OSE regarding this potential impact.

9.7 State Historical Society of North Dakota

In a letter dated September 28, 2017, the State Historical Society indicated the "Harmony Solar ND, LLC Class I and Class III Inventory in Cass County, North Dakota" is acceptable. There has been a good faith effort to identify and avoid impacts to "significant sites", provided the project remains as described and mapped in the Area M report dated September & October 2016.

The Project footprint has not changed since the SHPO review; as such, no impacts are anticipated.

9.8 Cass County

The solar facility is located in Cass County, however local land use permitting occurs at the township level. Harmony has been coordinating with Cass County staff since 2017 and the Cass County Commission have provided a letter of support for the Project (Refer to Appendix C).

9.9 Harmony Township

The Project was presented at a Harmony Township meeting in early 2017 prior to applying for a Conditional Use Permit. Harmony received a Conditional Use Permit from Harmony Township in August of 2017. The Township strongly supports the Project and has provided a letter of support (Refer to Appendix C).

9.10 Cass County Soil Conservation District

Harmony provided proposed seed mix options to the Cass County Soil Conservation District for input and recommendations. In an email dated May 30, 2018, Mr. Jeffrey Miller indicated the mixes were excellent, well thought out, and will grow well in the area.

9.11 Rush River Water Resource District

Harmony began coordination with the Rush River Water Resource District in early 2017 to identify and ensure avoidance of their easements along the Lower Rush River. In an email dated January 27, 2017, Mr. Mike Opat identified himself as the engineer for the Rush River Water Resource District. Mr. Opat identified the activities that would require a permit from the Rush River Water Resource District if conducted within their easements. In a subsequent email dated February 14, 2017, Mr. Opat provided copies of maps depicting the right-of-way of the Lower Rush River. Harmony has incorporated the easements into the Site Plan. The Project will cross under one easement with a collection line (the temporary impact outside the fence); Harmony will coordinate with the Rush River Water Resource District for a utility permit to cross this easement prior to construction.

10.0 QUALIFICATIONS OF CONTRIBUTORS TO SITING STUDY

Melissa Schmit

Senior Permitting Specialist, Geronimo Energy, LLC

Melissa Schmit has a Bachelor of Arts from Gustavus Adolphus College and a Juris Doctor from Hamline University School of Law. In her role at Geronimo, Melissa oversees and supports all aspects of regulatory compliance including environmental permitting and due diligence review for Geronimo's wind and solar portfolio. Melissa has over 10 years of experience permitting various energy infrastructure across the Midwest and southwestern United States.

Michael Morris

Director of Resource Analysis, Geronimo Energy, LLC

With over ten years of experience in the renewable energy industry, Michael has been responsible for siting, design, and resource assessment activities for over 5,000 megawatts of projects in eight states. His areas of expertise include atmospheric remote sensing, numerical modeling and statistical analysis of weather data. Michael holds a Bachelor of Science and a Master of Science in Meteorology from the University of Oklahoma.

Jay Hesse

Project Manager, Geronimo Energy, LLC

Jay manages Geronimo's North Dakota office and develops Geronimo's renewable energy projects in North Dakota and South Dakota, including Harmony. He serves as the first point of contact for landowners and community groups. Jay holds a Bachelor of Science from Saint Cloud University.

Betsy Engleking

Vice President of Policy and Strategy, Geronimo Energy, LLC

Betsy holds more than 25 years of experience in the energy industry including the Minnesota Public Utilities Commission as a rate analyst where she oversaw the implementation of Integrated Resource Planning and advised on utility resource planning, ratemaking, and industry restructuring issues, a transmission analyst and Manager of Resource Planning for a private utility, and the Director of Resource Planning and Bidding for a public utility. In her current role with Geronimo, Betsy's responsibilities include oversight over Geronimo's regulatory and legislative matters, as well as evaluation of commercial markets for wind and solar energy. Betsy holds a Bachelor of Science from the College of William and Mary in Virginia and a Master of Business Administration from the Carlson School of Management from the University of Minnesota.

Mollie Smith

Ms. Smith assists clients with wind farm, solar, pipeline, and transmission line permitting matters in North Dakota, South Dakota, and Minnesota. Her experience includes representing clients in state and local administrative proceedings, including certificate of corridor compatibility, route permit, and certificate of site compatibility proceedings before the North Dakota Public Service Commission; facility permit proceedings before the South Dakota Public Utilities Commission; and certificate of need, route permit and site permit proceedings before the Minnesota Public Utilities Commission. Ms. Smith has a B.A. in English from Northern State University, Aberdeen, SD; and M.A. in Literature from Colorado State University, Fort Collins, CO; and a J.D. from the University of Minnesota Law School, Minneapolis, MN.

Brie Anderson

Senior Project Manager/Environmental Analyst at Merjent, Inc.

Brie holds a Bachelor of Science in Ecology and Field Biology with an emphasis in Wildlife Biology, and Geographic Information Systems from St. Cloud State University and a Master of Science in Geographic Information Systems from St. Mary's University of Minnesota. In her role at Merjent, Brie oversees and supports all aspects of regulatory compliance including environmental permitting and due diligence review for energy infrastructure development projects, with an emphasis on wind and solar development projects. Brie has over 10 years of experience permitting wind, solar, and transmission projects across the Midwest.

Monika Hagebak Davis

Senior Project Manager/Environmental Analyst at Merjent, Inc.

Monika holds a Bachelor of Arts in Anthropology/Archaeology from the University of Minnesota. In her role at Merjent, Monika oversees and supports all aspects of regulatory compliance including environmental permitting and due diligence review for energy infrastructure development projects. Monika has over 16 years of experience permitting pipeline and transmission line projects throughout the contiguous U.S.

Kate Mize

Senior Environmental Analyst at Merjent, Inc.

Kate holds a Bachelor of Science in Environmental Science with an emphasis in Land Use Management and Soils from the University of Minnesota. In her role at Merjent, Kate specializes in soil impact and mitigation analyses and oversight of multi-discipline field surveys for energy infrastructure development projects throughout the U.S. Kate has 13 years of experience permitting energy infrastructure development projects throughout the contiguous U.S.

Brian Schreurs

Senior GIS Specialist at Merjent, Inc.

Brian holds a Bachelor of Science in Geography and a Master of Science in Geography and Applied GIS from St. Cloud State University. In his role at Merjent, Brian provides GIS analysis and support for environmental impact analysis and siting/routing/feasibility studies for energy infrastructure development projects. Brian has over 17 years of experience providing GIS analysis for environmental permitting throughout the Midwest.

11.0 REFERENCES

- Anderson, F.J. 2011. Depth to Bedrock in the Fargo Area, North Dakota. Available online at https://www.dmr.nd.gov/ndgs/documents/Publication_List/pdf/geoinv/GI_142.pdf. Accessed May 2018.
- Bluemle, J.P. 1977. Surface Geology of North Dakota by North Dakota Geological Survey. Available online at https://www.ndsu.edu/nd_geology/nd_maps/nd_map2.htm. Accessed May 2018.
- Briberg, J.S. 2016. Utility & Community Solar Should Use Native Landscaping. Clean Technica blog. Available online at: <https://cleantechnica.com/2016/03/15/utility-and-community-solar-should-use-native-landscaping/>. Accessed May 2018.
- Caceres, M.C and R.M.R. Barclay. 2000. *Myotis septentrionalis*. Mammalian Species 634:1-4.
- Canadian Wildlife Service and United States Fish and Wildlife Service (“USFWS”). 2007. International recovery plan for the Whooping Crane. Ottawa, Ontario and Albuquerque, New Mexico. 162 p.
- Johnson, S. 2016. Reptiles and Amphibians of North Dakota. North Dakota Game and Fish Department, Bismarck, ND. Available at <https://gf.nd.gov/gnf/conservation/docs/amphibian-reptile-brochure.pdf>. Accessed May 2018.
- Lazard’s Levelized Cost of Energy Analysis 10.0 (Lazard). 2016. Available at <https://www.lazard.com/perspective/levelized-cost-of-energy-analysis-100/>. Accessed March 2017.
- Licht, D.S. and S.H. Fritts. 1994. Gray wolf (*Canis lupus*) occurrences in the Dakotas. American Midland Naturalist 132:74-81.
- National Centers for Environmental Information (NCEI). 2015. Comparative Climatic Data for Fargo, ND. Available at <https://www.ncdc.noaa.gov/ghcn/comparative-climatic-data>. Accessed May 2018.
- National Radiation Laboratory, Ministry of Health, New Zealand. 2008. Electric and Magnetic Fields and Your Health: Information on electric and magnetic fields associated with transmission lines, distribution lines, and electrical equipment. Available at http://www.who.int/peh-emf/project/mapnatreps/nznrl_emfbooklet2008.pdf. Accessed May 2018.
- North Dakota Department of Health (NDDH). 2016. Annual Report: North Dakota Ambient Monitoring Network Plan with Data Summary. Available at https://deq.nd.gov/DataPDFs/AQ/Monitoring/Monitoring_Annual_Reports/ARNP_16-17.pdf. Accessed May 2018.

- North Dakota Division of Oil and Gas. 2018. Oil and Gas Well Map – Web Application. Available <https://gishubdata.nd.gov/dataset/oil-and-gas-division-oil-and-gas-map/resource/56563167-3051-40b0-8d50-9d803bd8b994>. Accessed May 2018.
- North Dakota Department of Transportation (NDDOT). 2016. 2016 Traffic Volume Map – State of North Dakota. Available online at: http://www.dot.nd.gov/docs/maps/traffic/trafficstate_2016.pdf. Accessed May 2018.
- North Dakota Game and Fish Department (NDGFD). 2015. 2015 State Wildlife Action Plan. Available at <https://gf.nd.gov/wildlife/swap>. Accessed May 2018.
- NDGFD. 2016a. Fish and Wildlife Species Identification. Available at <https://gf.nd.gov/wildlife/id>. Accessed May 2018.
- NDGFD. 2016b. Gray Wolf. Available at <https://gf.nd.gov/wildlife/id/carnivores/wolf>. Accessed May 2018.
- NDGFD. 2016c. Species of Conservation Priority. Available at <https://gf.nd.gov/wildlife/scp#1>. Accessed May 2018.
- Renewable Choice Energy. 2017. The Rise of the Corporate Energy Buyer. Available at <https://www.renewablechoice.com/blog-corporate-energy-buyer/>. Accessed May 2018.
- Soil Survey Staff, Natural Resources Conservation Service (NRCS), U.S. Department of Agriculture (USDA). 2018. Web Soil Survey. Available online at the following link: <https://websoilsurvey.sc.egov.usda.gov/>. Accessed 5/2018.
- Timpone, J.C., J.G. Boyles, K.L. Murray, D.P. Aubrey, and L.W. Robbins. 2010. Overlap in roosting habits of Indiana bats (*Myotis sodalis*) and northern bats (*Myotis septentrionalis*). *The American Midland Naturalist* 163:115-123.
- U.S. Census Bureau. 2010. Fact Finder, 2010 Census. Available online at: https://factfinder.census.gov/faces/nav/jsf/pages/community_facts.xhtml#none. Accessed April 2018.
- U. S. Census Bureau. 2016. 2012 - 2016 American Community Survey 5-year Estimates. Available online at: Accessed April 2018. https://factfinder.census.gov/faces/nav/jsf/pages/community_facts.xhtml#none. Accessed April 2018.
- USDA. 2012. 2012 Census of Agriculture. Available online at: <https://www.agcensus.usda.gov/Publications/2012/>. Accessed April 2018.
- USDA National Agriculture Statistics Service. 2017. 2017 Agricultural Statistics Annual. Available online at https://www.nass.usda.gov/Publications/Ag_Statistics/2017/index.php. Accessed May 2018.

- USDA, NRCS. 2018. National soil survey handbook, title 430-VI.
http://www.nrcs.usda.gov/wps/portal/nrcs/detail/soils/ref/?cid=nrcs142p2_054242.
Accessed 11/2018.
- U.S. Environmental Protection Agency (EPA). 2017. Ecoregion Download Files by State – Region 8, Maps, Level IV Ecoregions of North Dakota and South Dakota. Available online at:
<https://www.epa.gov/eco-research/ecoregion-download-files-state-region-8#pane-32>.
Accessed April 2018.
- EPA. 2018. Superfund: National Priorities List. Available online at
<https://www.epa.gov/superfund/superfund-national-priorities-list-npl>. Accessed May 2018.
- U.S. Fish & Wildlife Service (USFWS). 2006. Designating the Western Great Lakes Population of Gray Wolves as a Distinct Population Segment: Removing the Western Great Lakes Distinct Population Segment of the Gray Wolf from the List of Endangered and Threatened Wildlife: Proposed Rule. 71 Federal Register 15266 (March 27, 2006). Available at
https://www.fws.gov/midwest/wolf/archives/2006pr_dl/PDF/2006pr_dl.pdf. Accessed March 2018.
- USFWS. 2007. National Bald Eagle Management Guidelines. Arlington, VA. May 2007. Available at:
<http://www.fws.gov/midwest/eagle/pdf/NationalBaldEagleManagementGuidelines.pdf>.
Accessed May 2018.
- USFWS. 2008. Birds of Conservation Concern 2008. U.S. Fish & Wildlife Service Division of Migratory Bird Management, Arlington, Virginia. 85 pp. Available at:
<https://www.fws.gov/migratorybirds/pdf/grants/BirdsofConservationConcern2008.pdf>.
Accessed May 2018.
- USFWS. 2010. North Dakota Whooping Crane Migratory Corridor. Available at
http://www.ndnrt.com/image/cache/ND_Whooping_Crane_Migration_Corridor_high-res.pdf. Accessed May 2018.
- USFWS. 2015a. North Dakota ES – Wind Power. Available at
<https://www.fws.gov/northdakotafieldoffice/wind.php>. Accessed May 2018.
- USFWS. 2015b. Endangered and Threatened Wildlife and Plants; Listing the Northern Long-Eared Bat With a Rule Under Section 4(d) of the Act. Federal Register 80:2371-2378. Available at:
<https://www.fws.gov/midwest/endangered/mammals/nleb/pdf/FRnlebProposed4dRule16Jan2015.pdf>. Accessed May 2018.
- USFWS. 2015c. Northern Long-Eared Bat (*Myotis septentrionalis*) factsheet. Available at
<https://www.fws.gov/midwest/endangered/mammals/nleb/nlebFactSheet.html>. Accessed May 2018.

- USFWS. 2015d. Endangered and Threatened Wildlife and Plants; Reinstatement of Final Rules for the Gray Wolf in Wyoming and the Western Great Lakes in Compliance With Court Orders. 80 Federal Register 9218. February 20, 2015. Available at <https://www.fws.gov/midwest/wolf/archives/2011FinalDelisting/pdf/FRWolfReinstatementNotice20Feb2015.pdf>. Accessed May 2018.
- USFWS. 2016. Endangered and Threatened Wildlife and Plants; Listing the Northern Long-Eared Bat With a Rule Under Section 4(d) of the Act; Final Rule. 81 Federal Register 1900 (14 January 2016). Available at <https://www.fws.gov/midwest/endangered/mammals/nleb/pdf/FRnlebFinal4dRule14Jan2016.pdf>. Accessed March 2018.
- USFWS. 2017. Migratory Bird Treaty Act. Available online at: <https://www.fws.gov/birds/policies-and-regulations/laws-legislations/migratory-bird-treaty-act.php>. Accessed May 2018.
- USFWS. 2018a. Information for Planning and Consultation: Cass County, North Dakota. Available at <https://ecos.fws.gov/ipac/>. Accessed May 2018.
- USFWS. 2018b. Northern Long-eared Bat Final 4(d) Rule: White-Nose Syndrome Zone Around WNS/Pd Positive Counties/Districts (April 30, 2018) Available at <https://www.fws.gov/Midwest/endangered/mammals/nleb/pdf/WNSZone.pdf>. Accessed May 2018.
- USFWS. 2018c. Northern Long-eared Bat: Key to the Northern Long-Eared Bat 4(d) Rule for Non-Federal Activities. Available at <https://www.fws.gov/Midwest/endangered/mammals/nleb/KeyFinal4dNLEB.html>. Accessed May 2018.
- U.S. Geological Survey (USGS). 2011. Gap Analysis Program (GAP). August 2011. National Land Cover, Version 2. Available online at: <https://gapanalysis.usgs.gov/gaplandcover/viewer/>. Accessed May 2018.
- Westwood Professional Services. 2016. Preliminary Hydrology Study, Harmony Solar Project, Cass County, ND.
- WDNR. 2015. Northern Long-eared Bat (*Myotis septentrionalis*) Species Guidance. Available at: <http://dnr.wi.gov/topic/EndangeredResources/Animals.asp?mode=detail&SpecCode=AMACC01150>. Accessed May 2018.

Figures

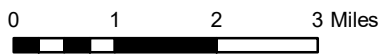
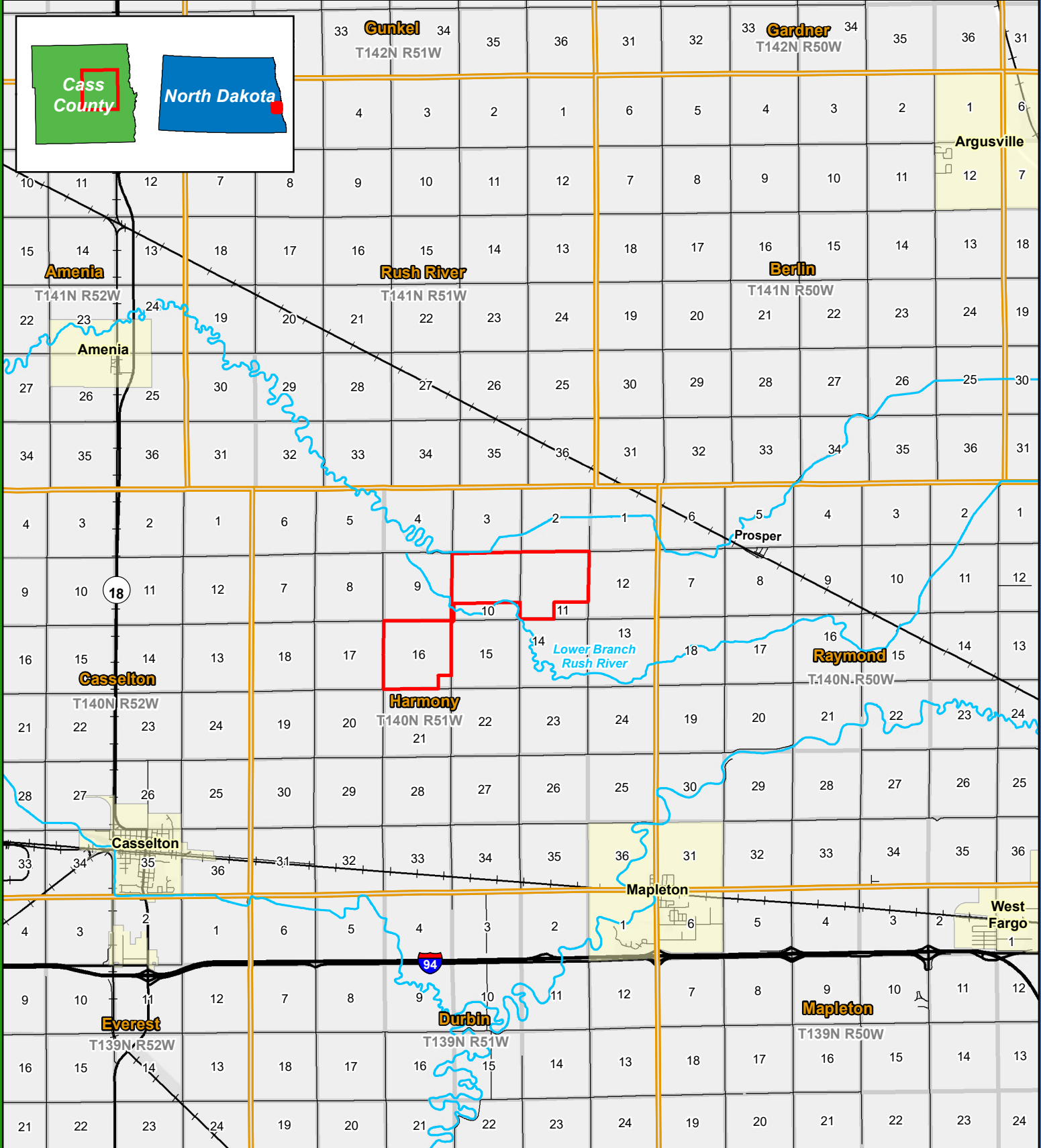
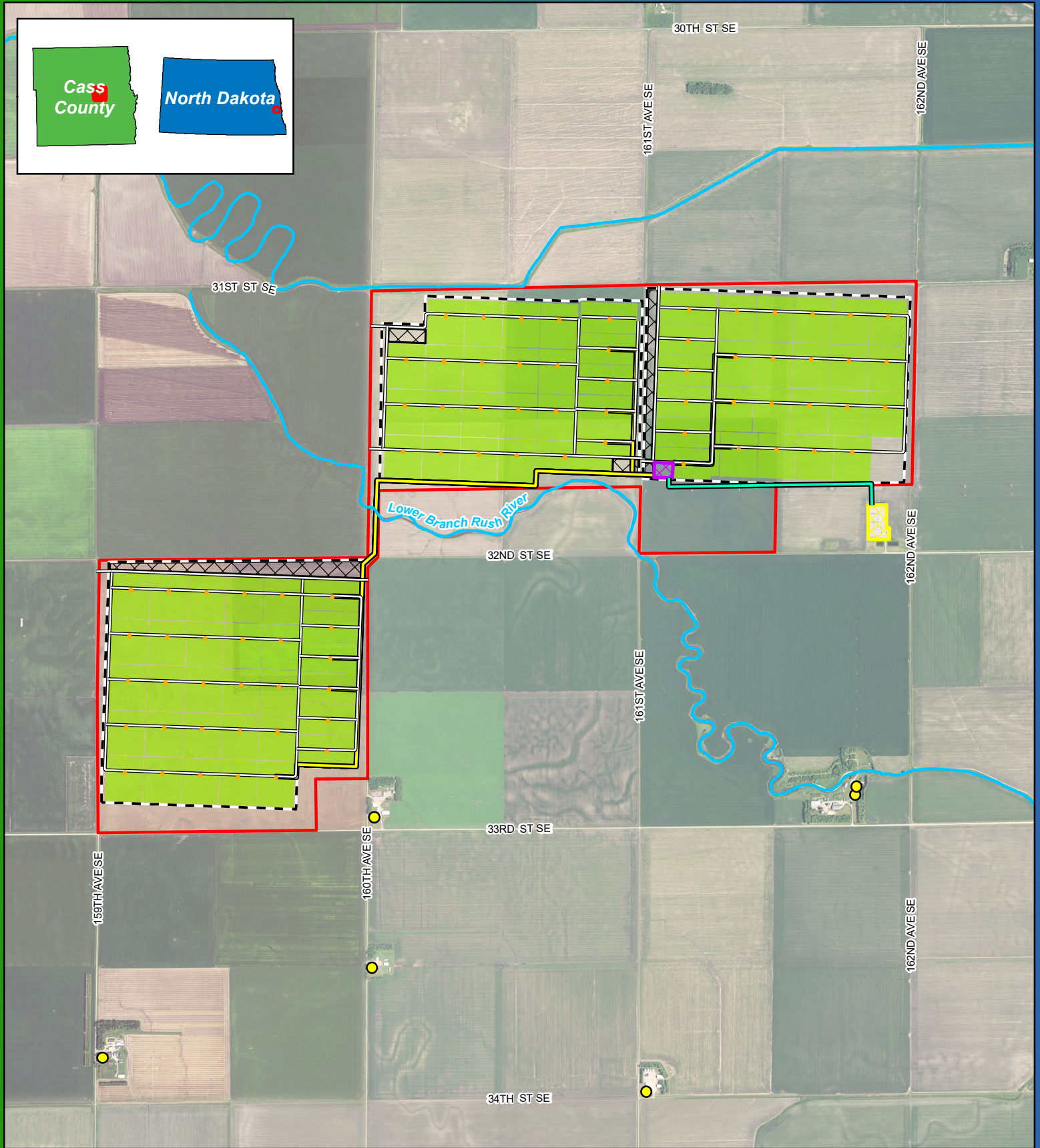
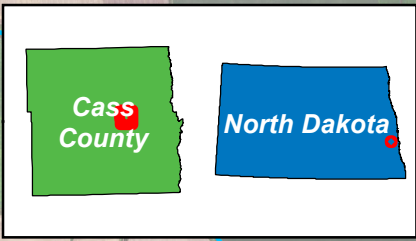

Figure 1
Project Location
Harmony Solar Project
Cass County, ND
46.951802, -97.106153

- Project Area
- City/Town
- Township
- ~ NHD Named Stream
- County/Local Road
- State/Federal Road
- Railroad
- PLSS Section Boundary



0 0.25 0.5 0.75 Miles



1:30,000

Figure 2
Project Facilities
Harmony Solar Project
Cass County, ND
46.951802, -97.106153

- | | |
|-------------------|---------------------------------|
| Project Area | Existing Substation |
| Security Fence | Project Substation/O&M Facility |
| Access Road | Laydown Area |
| Transmission Line | NHD Named Stream |
| Collection Line | Residence |
| Solar Array | |
| Inverter | |

Note: See Appendix A for detail

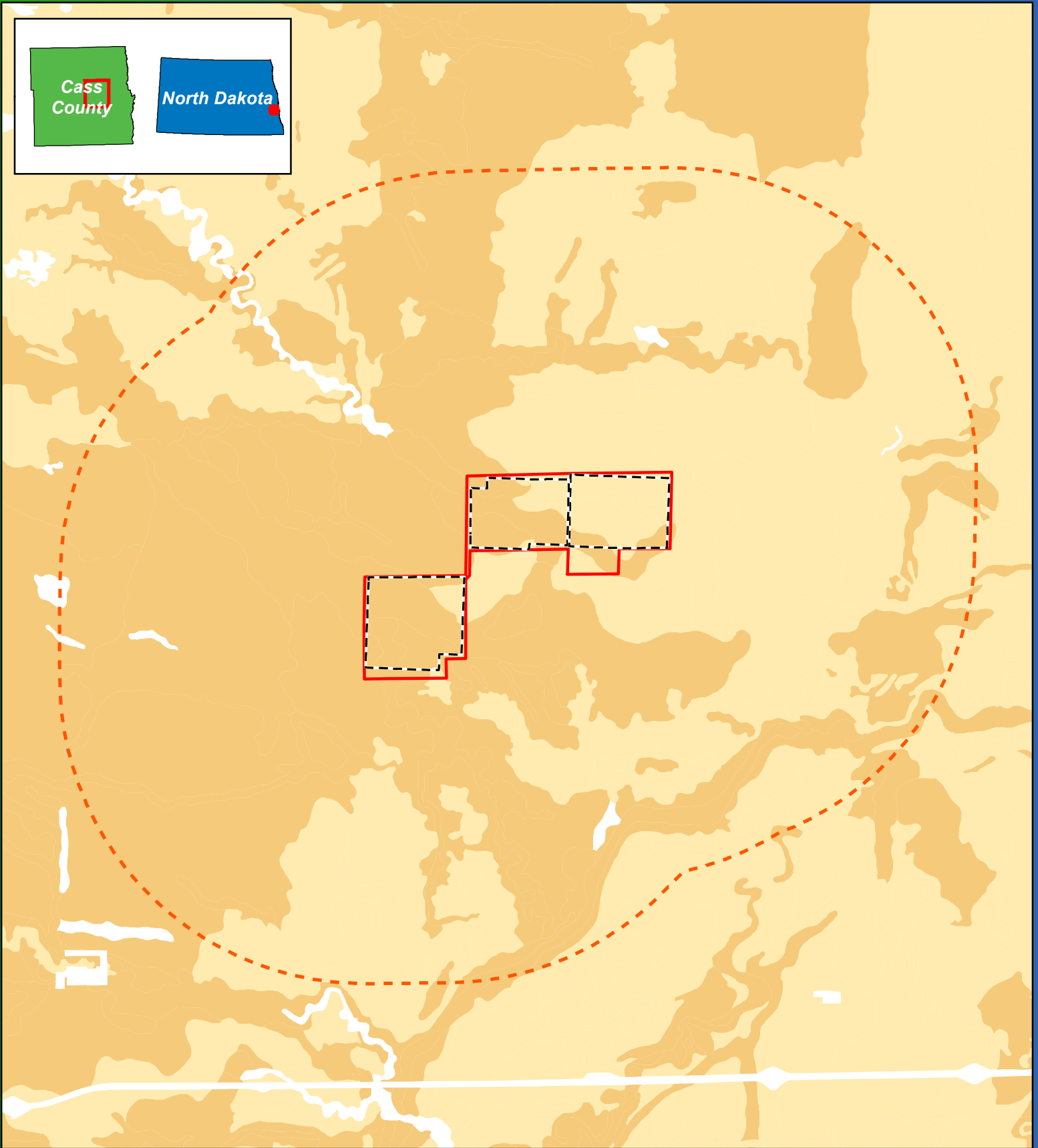
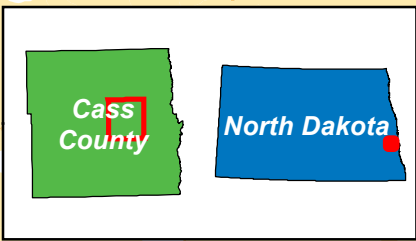





0 1 2 Miles



1:80,000

Figure 3
Exclusion Area
Harmony Solar Project
Cass County, ND
46.951802, -97.106153

-  Project Area
-  Study Area
-  Fence Line
- Exclusion Area**
-  Prime farmland
-  Prime farmland if drained

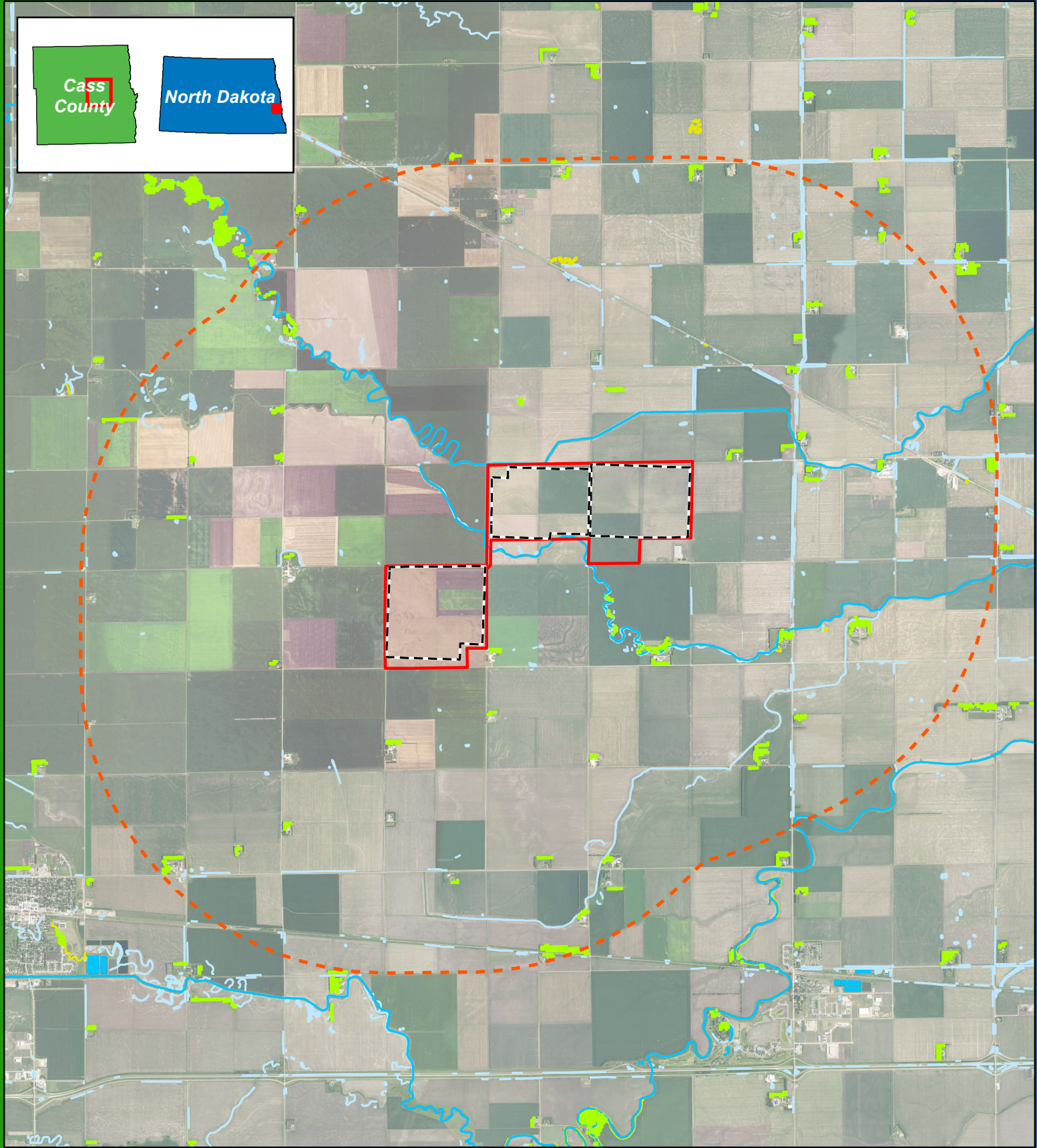
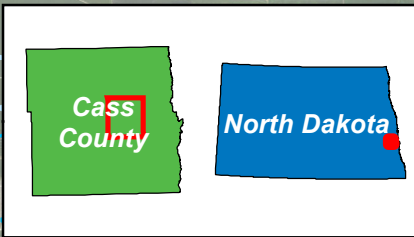

0 1 2 Miles



1:80,000

Figure 4
Avoidance Areas
Harmony Solar Project
Cass County, ND
46.951802, -97.106153

- Project Area
- Study Area
- Fence Line
- Avoidance Area**
- Forest & Woodland
- NHD Named Stream
- Freshwater Emergent Wetland
- Freshwater Forested/Shrub Wetland
- Freshwater Pond

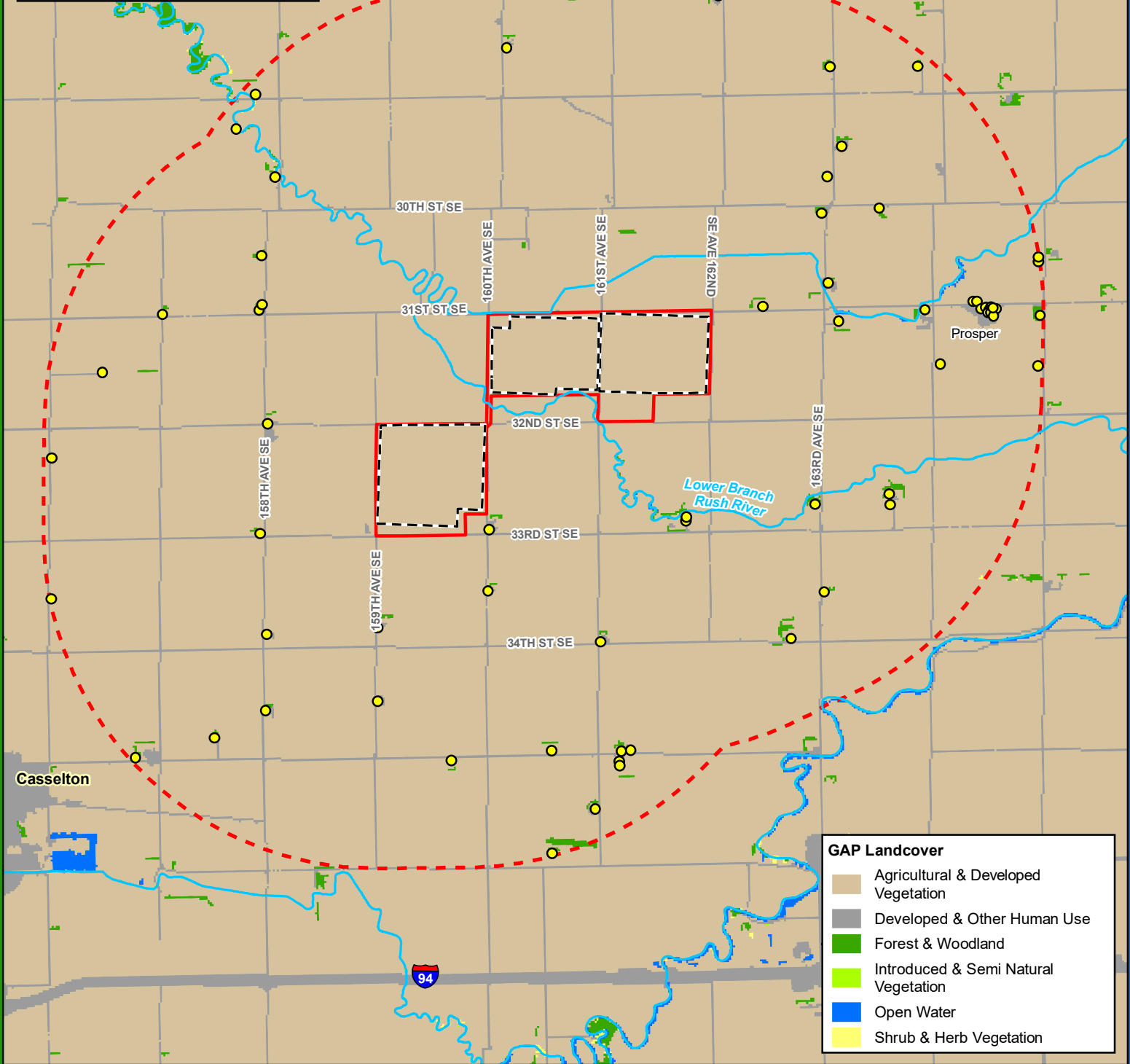
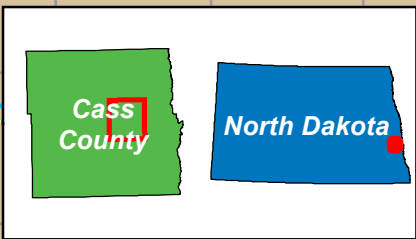

GAP Landcover	
	Agricultural & Developed Vegetation
	Developed & Other Human Use
	Forest & Woodland
	Introduced & Semi Natural Vegetation
	Open Water
	Shrub & Herb Vegetation



0 1 2 Miles



1:80,000

Figure 5
Landuse/Landcover
Harmony Solar Project
Cass County, ND
46.951802, -97.106153

- Project Area
- Study Area
- Fence Line
- NHD Named Stream
- Residence

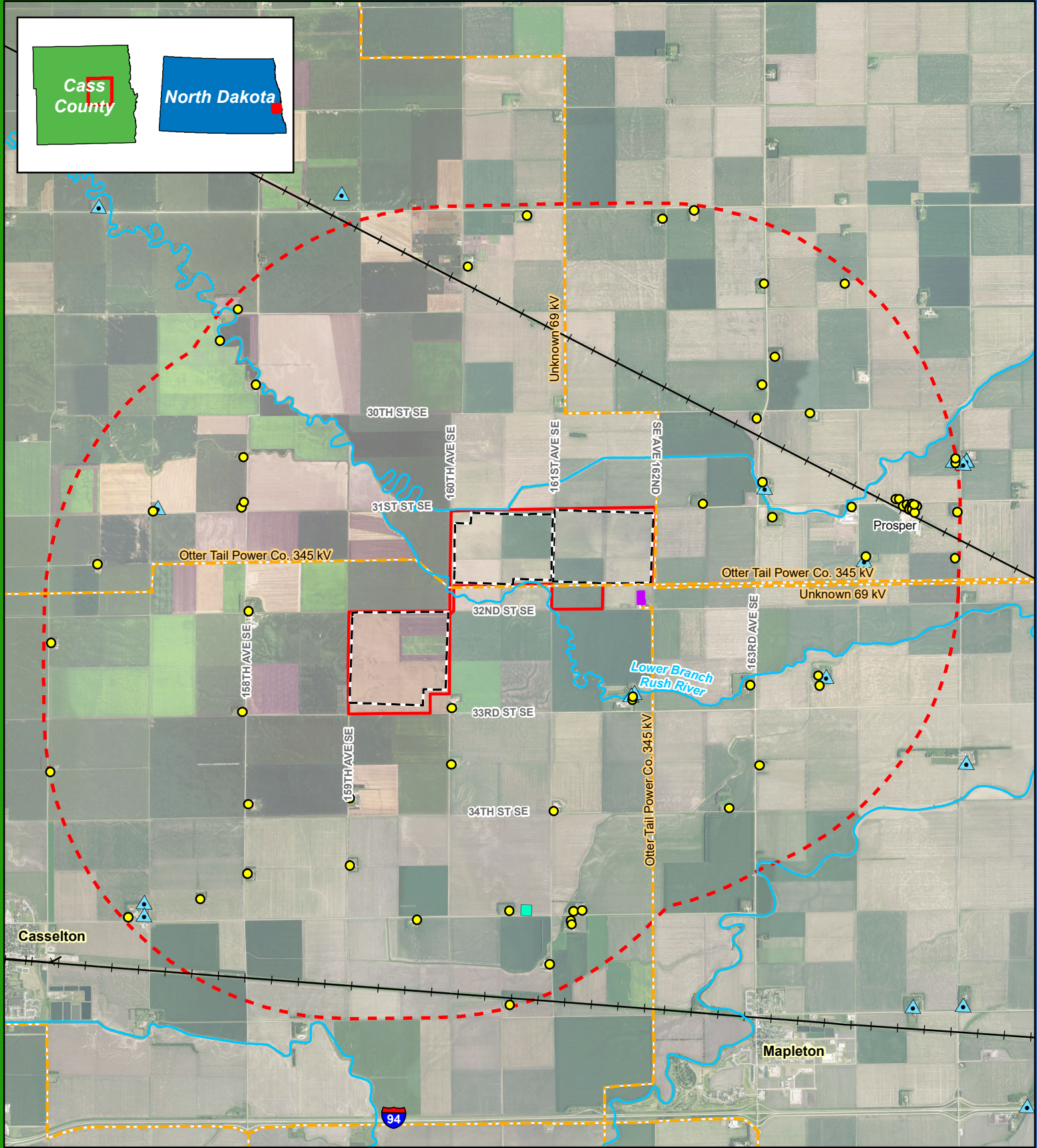
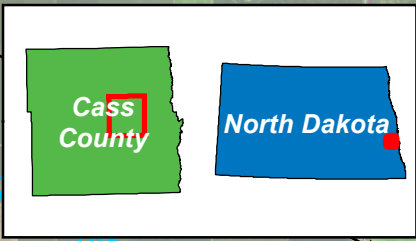

0 1 2 Miles



1:80,000

Figure 6
Existing Infrastructure
Harmony Solar Project
Cass County, ND
 46.951802, -97.106153

- Project Area
- Study Area
- Fence Line
- Residence
- Well
- Private Landing Strip
- Existing Transmission Line
- NHD Named Stream
- Existing Substation
- Railroad

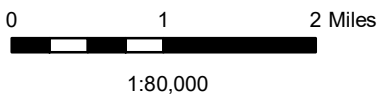
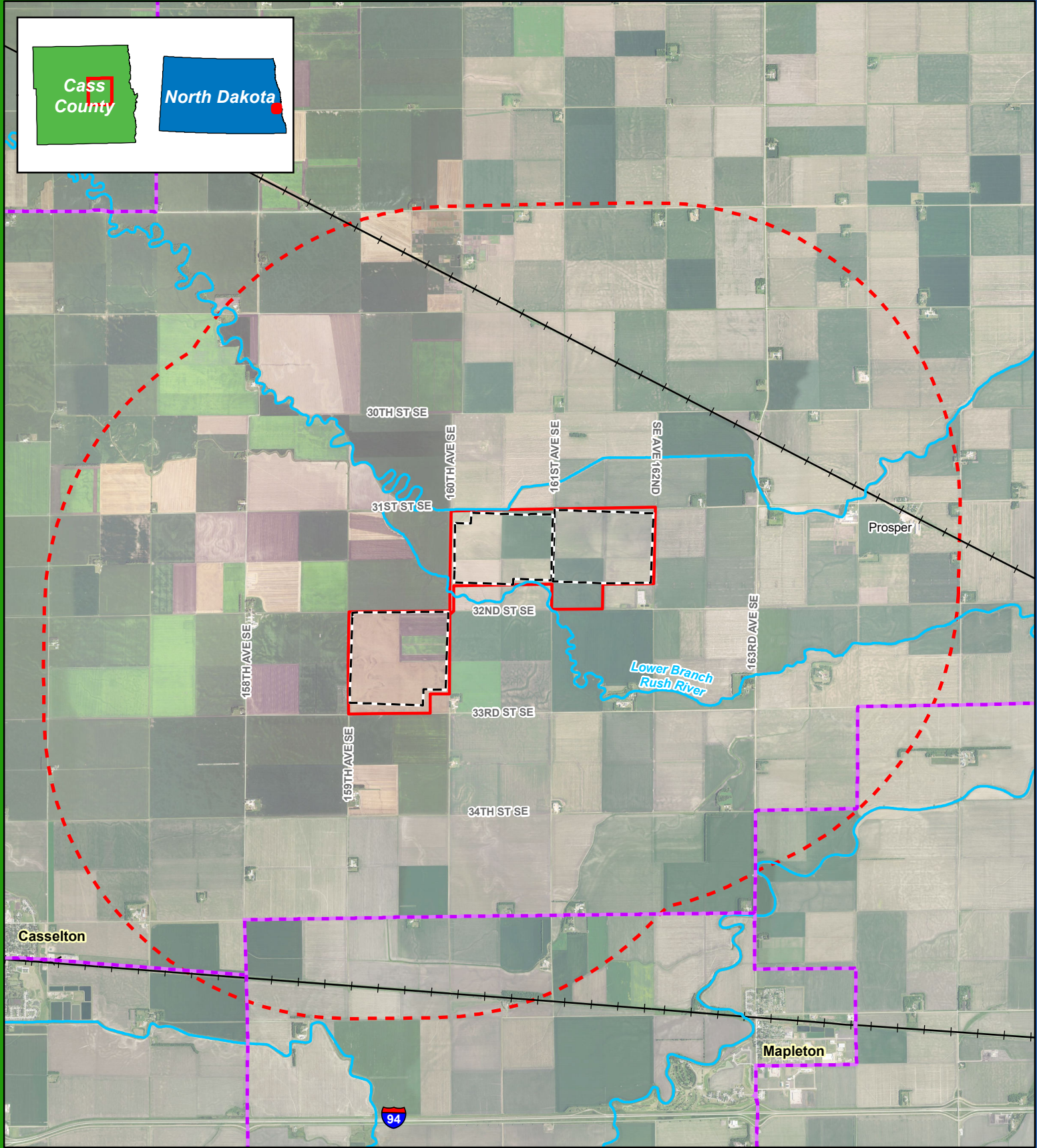
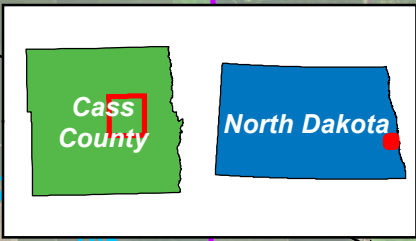
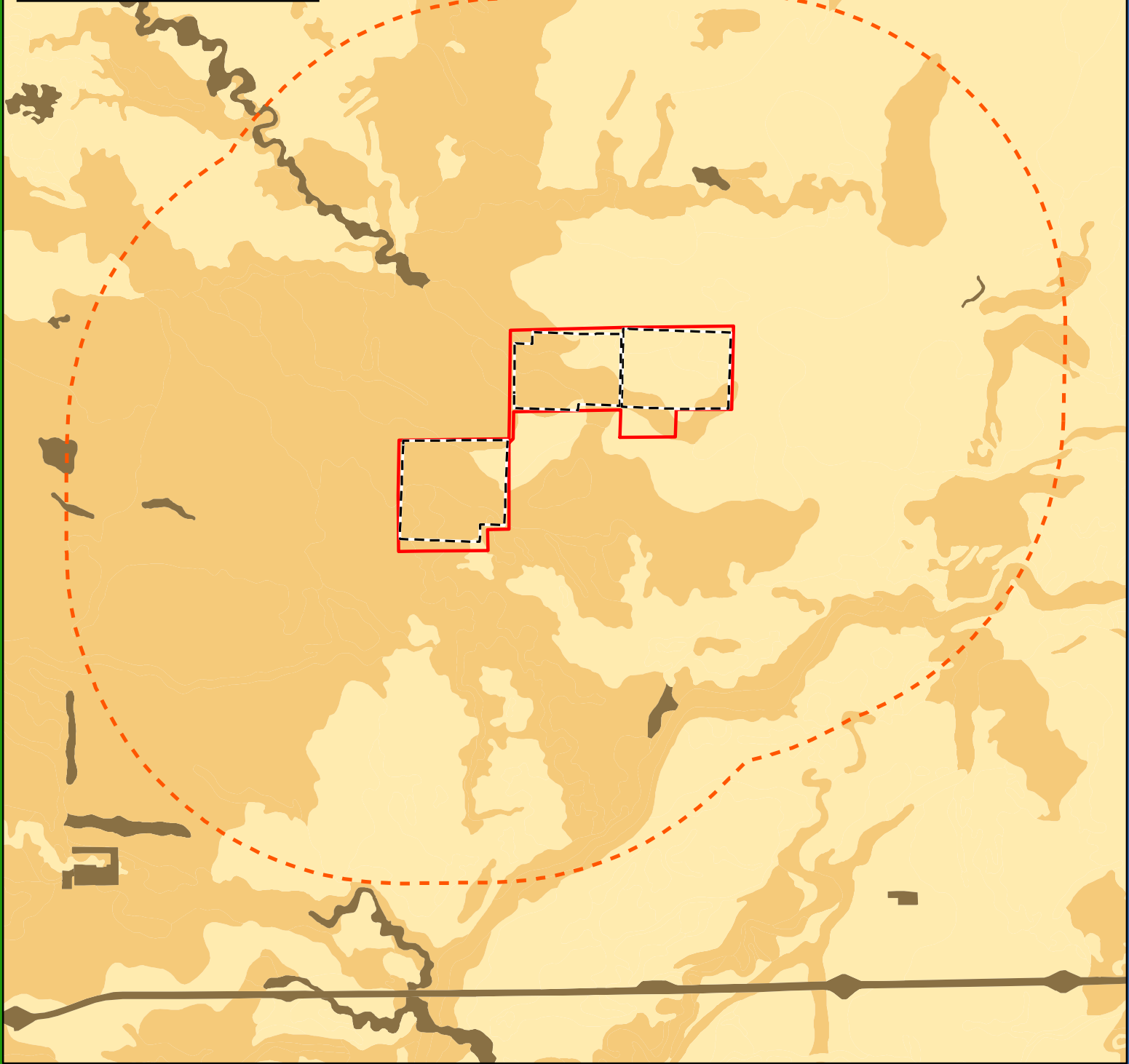
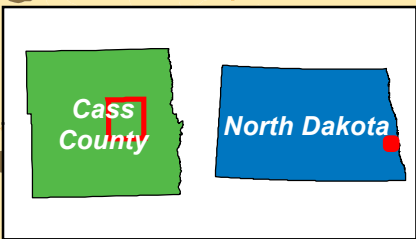

Figure 7
Recreation
Harmony Solar Project
Cass County, ND
46.951802, -97.106153

- Project Area
- Study Area
- Fence Line
- East Central Valley Snowmobile Trail
- Railroad
- NHD Named Stream



0 1 2 Miles



1:80,000

Figure 8
Prime Farmland
Harmony Solar Project
Cass County, ND
46.951802, -97.106153

-  Project Area
-  Study Area
-  Fence Line
-  Prime farmland
-  Not prime farmland
-  Prime farmland if drained

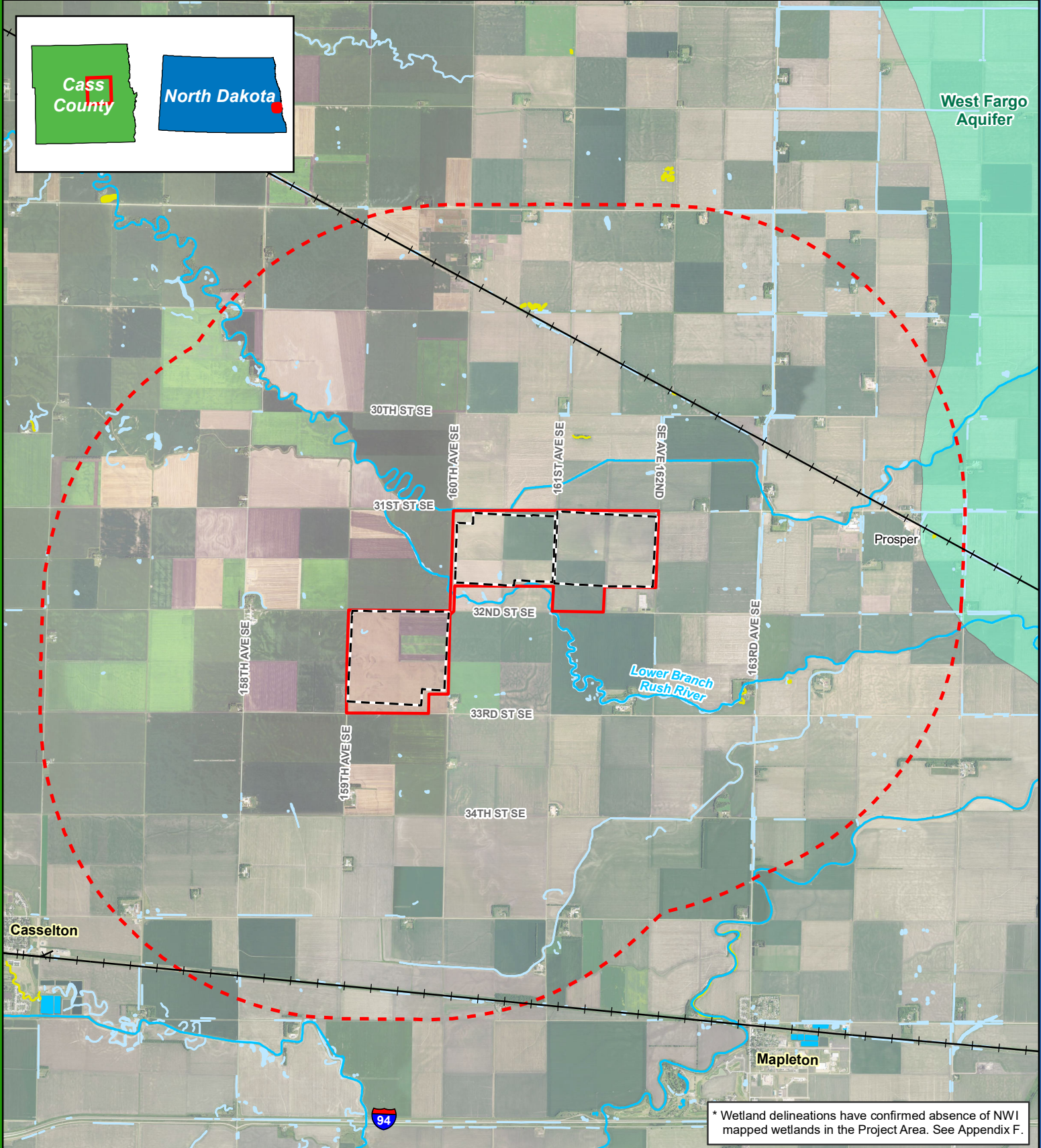

Figure 9
Water Features
Harmony Solar Project
Cass County, ND
46.951802, -97.106153

- Project Area
- Study Area
- Fence Line
- Railroad
- NHD Named Stream
- Surficial Aquifer
- NWI Wetland ***
- Freshwater Emergent Wetland
- Freshwater Forested/Shrub Wetland
- Freshwater Pond

* Wetland delineations have confirmed absence of NWI mapped wetlands in the Project Area. See Appendix F.



0 1 2 Miles
 1:80,000

Harmony Solar Project
Appendix A
Project Site Plan

Harmony Solar ND, LLC

200 MW-AC Solar Array Project Cass County, ND Issued For Permit

Project Contact Information

Consultant	Company	Name	Phone No.
Developer	Geronimo Energy	Tena Monson	(952) 358-5683
Project Manager	Westwood	August Christensen	(952) 906-7430
Civil Engineer	Westwood	Rob Copouls	(952) 906-7470
Land Surveyor	Westwood	Chris Høglund	(952) 906-7453

Data Set Information

Base File	File Name	Provider	Date
PV Array	0007695PVSITE.dwg	Westwood	05/19/2017
ALTA	0007695SURV.dwg	Westwood	05/22/2017
Topo	0007695DTM.dwg	MN Lidar	02/08/2016

Legal Description

Section 10-140-51, Part of Section 11-140-51 (excludes substation area), The Northwest Quarter of Section 15-140-51, and Section 16-140-51.

Project Description

200 MW-AC Single Axis Tracker Solar Project

Basis of Elevation

Contours shown were generated from publicly available LIDAR data in the state of North Dakota.

Sheet List Table

Sheet Number	Sheet Title
T.100	Cover Sheet
C.100	Existing Conditions - 1
C.101	Existing Conditions - 2
C.102	Existing Conditions - 3
C.200	Overall Site Plan
C.300	Site Plan - 1
C.301	Site Plan - 2
C.302	Site Plan - 3
C.303	Site Plan - 4
C.304	Site Plan - 5
C.305	Site Plan - 6
C.306	Site Plan - 7
C.307	Site Plan - 8
C.308	Site Plan - 9
C.309	Site Plan - 10
C.310	Site Plan - 11
C.311	Site Plan - 12
C.400	Construction Details
C.401	Construction Details

Regional Map



SOURCE: MAP DATA ©2017 GOOGLE (NOT TO SCALE)

Vicinity Map

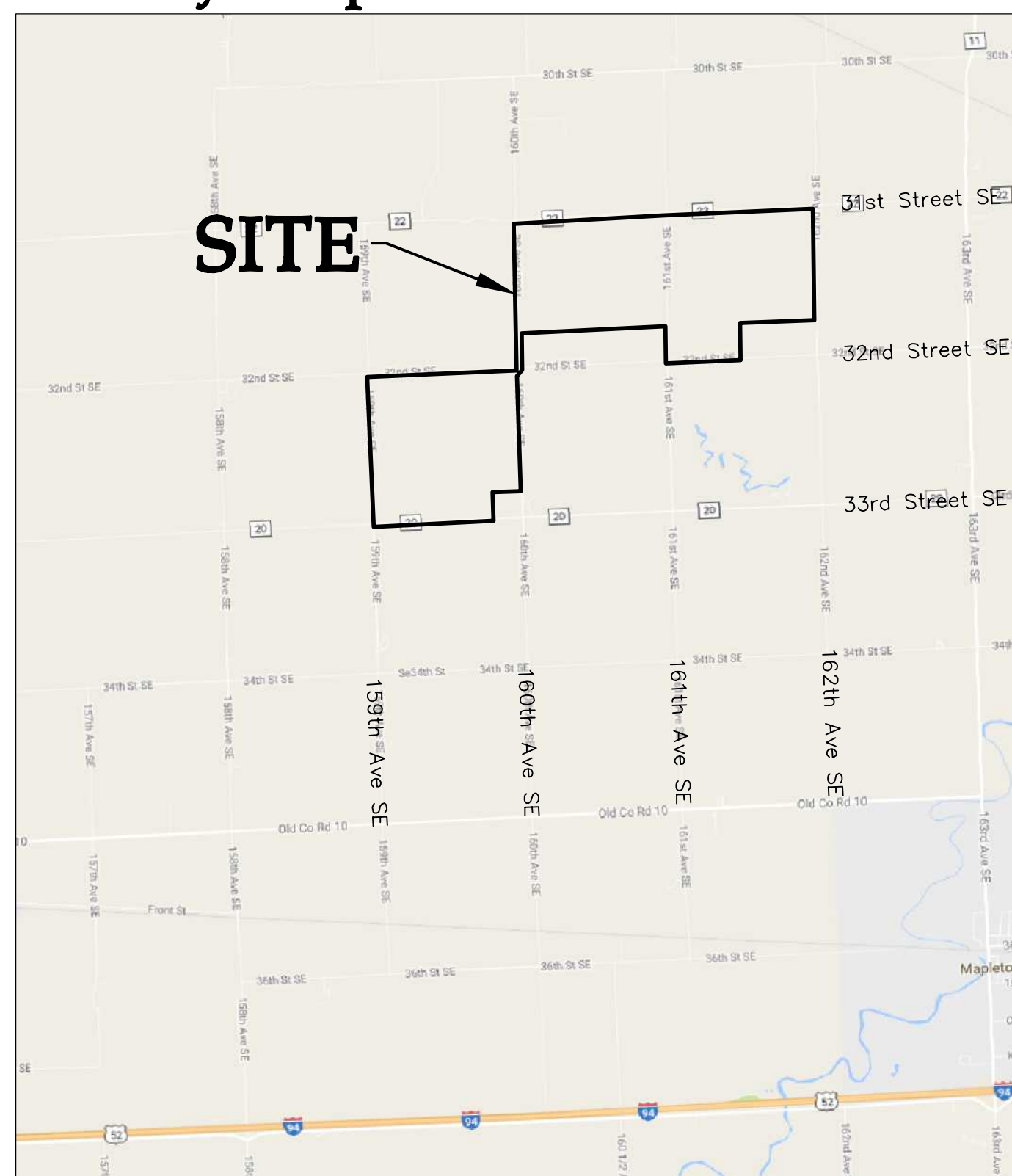

SOURCE: MAP DATA ©2017 GOOGLE (NOT TO SCALE)

Westwood

Phone (952) 937-5150 12701 Whitewater Drive, Suite #300
 Fax (952) 937-5622 Minnetonka, MN 55343
 Toll Free (888) 937-5150 westwoodps.com
 Westwood Professional Services, Inc.

Designed: BCV
 Checked: ADC
 Drawn: BCV

Record Drawing by/date:

Revisions:
 # DATE DESCRIPTION

Prepared for:

GERONIMO ENERGY
 Geronimo Energy,
 7650 Edinborough Way, Suite 725
 Edina, MN 55435

Harmony Solar ND, LLC
 Cass County, ND

Cover Sheet

Issued for Permit
 Not For Construction

Date: 06/25/18

Drawing No: T.100



LEGEND:

---	EX. PROJECT BOUNDARY LINE
---	EX. SECTION LINE
---	EX. EASEMENT LINE
---	EX. RIGHT-OF-WAY LINE
POH	EX. OVERHEAD POWERLINE
-1070-	EX. INDEX CONTOUR LINE
-1072-	EX. INTERVAL CONTOUR LINE
---	EX. PAVED ROAD
---	EX. GRAVEL ROAD
---	EX. WETLAND
---	EX. TRAVEL PATH
•	FOUND MOUNDMENT
○	EX. POWER POLE
EX.	EXISTING
S/B	SETBACK
1.00%	EX. GROUND GRADE

Existing Land Use

Agriculture	1,999.31 acres	100%
-------------	----------------	------

KEY MAP

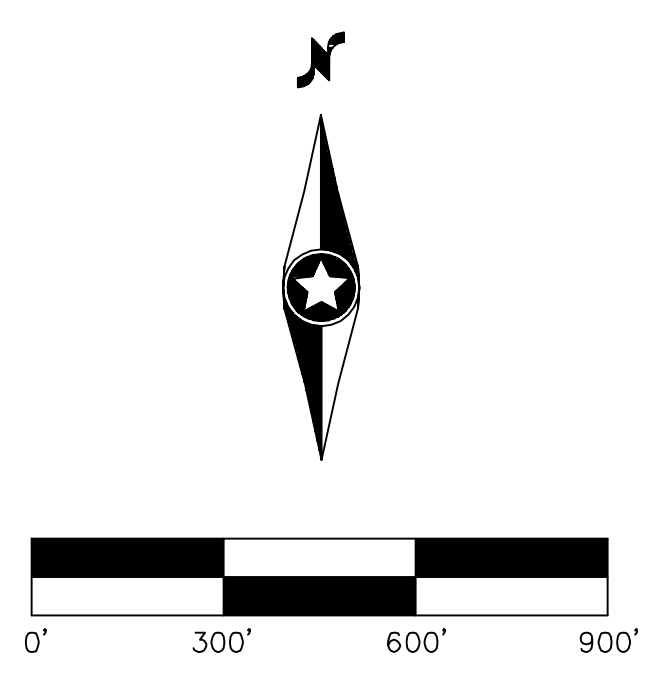
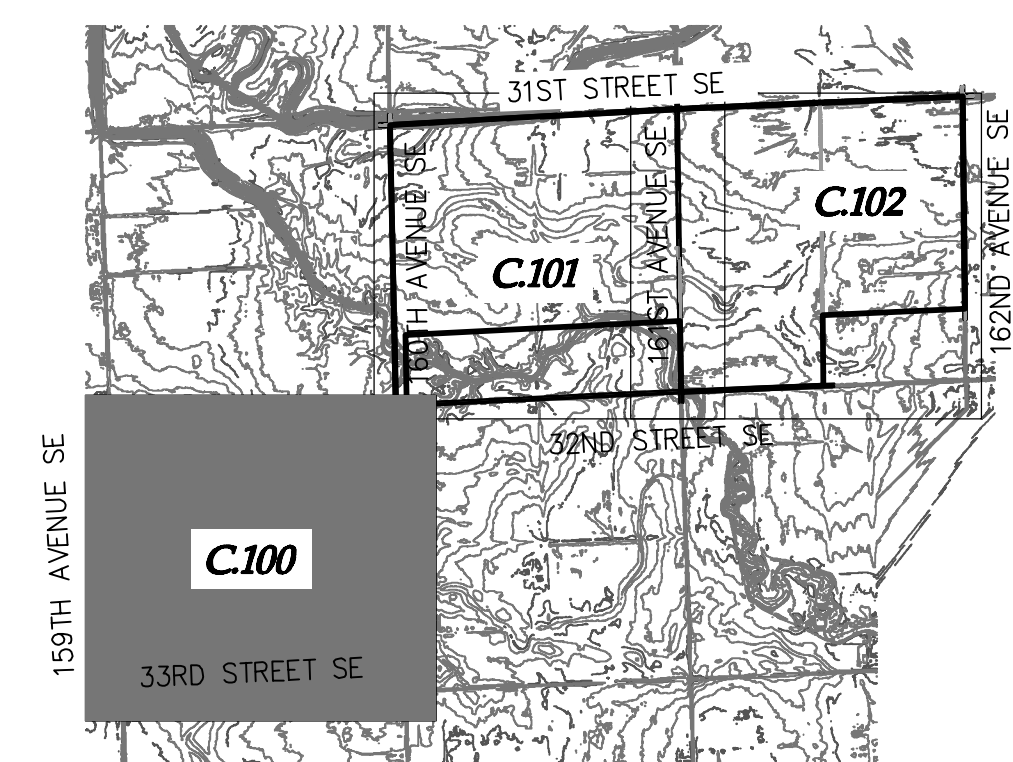

Westwood
 Phone (952) 937-5150 12701 Whitewater Drive, Suite #300
 Fax (952) 937-5822 Minnetonka, MN 55343
 Toll Free (888) 937-5150 westwoodsps.com
 Westwood Professional Services, Inc.

Designed: BCV
 Checked: ADC
 Drawn: BCV

Record Drawing by/date:

Revisions:

#	DATE	DESCRIPTION

Prepared for:

GERONIMO ENERGY
 Geronimo Energy,
 7650 Edinborough Way, Suite 725
 Edina, MN 55435

**Harmony Solar
 ND, LLC**
 Cass County, ND

Existing Conditions - 1

Issued for Permit
 Not For Construction

Date: **06/25/18**
 Drawing No: **C.100**



LEGEND:

---	EX. PROJECT BOUNDARY LINE
- - - -	EX. SECTION LINE
- · - · -	EX. EASEMENT LINE
- - - -	EX. RIGHT-OF-WAY LINE
— P.O.H. —	EX. OVERHEAD POWERLINE
- 1070 -	EX. INDEX CONTOUR LINE
- 1072 -	EX. INTERVAL CONTOUR LINE
▨	EX. PAVED ROAD
▩	EX. GRAVEL ROAD
▧	EX. WETLAND
▤	EX. TRAVEL PATH
●	FOUND MOUNDMENT
○	EX. POWER POLE
EX.	EXISTING
S/B	SETBACK
1.00%	EX. GROUND GRADE

Designed:	BCV
Checked:	ADC
Drawn:	BCV

Record Drawing by/date:

Revisions:	DATE	DESCRIPTION

Prepared for:

GERONIMO ENERGY
 Geronimo Energy,
 7650 Edinborough Way, Suite 725
 Edina, MN 55435

KEY MAP

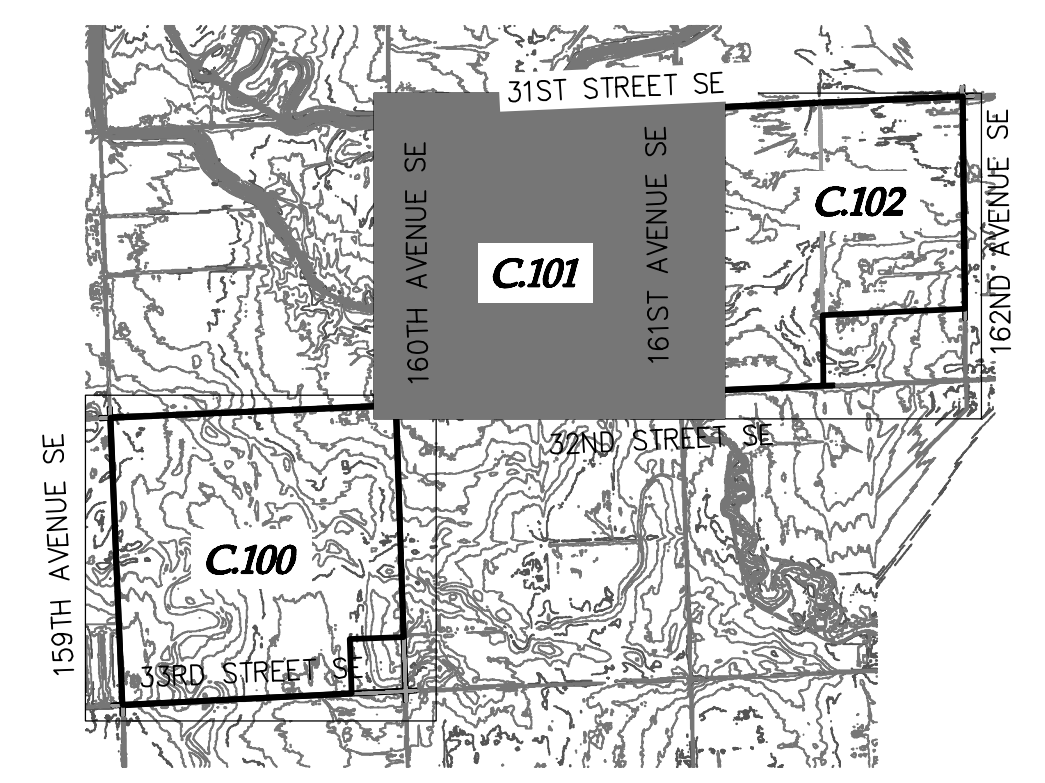

Harmony Solar ND, LLC
 Cass County, ND

Existing Conditions - 2

Issued for Permit
 Not For Construction

Date: 06/25/18
 Drawing No: C.101

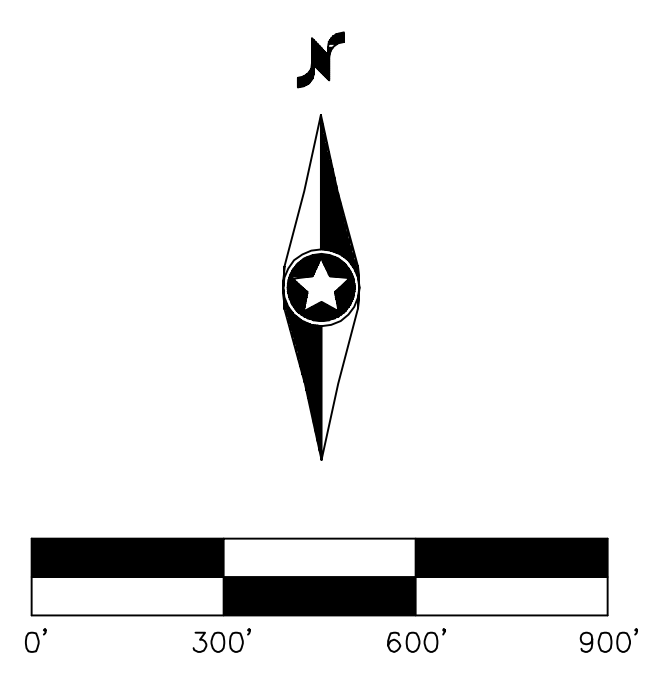



LEGEND:

---	EX. PROJECT BOUNDARY LINE
---	EX. SECTION LINE
---	EX. EASEMENT LINE
---	EX. RIGHT-OF-WAY LINE
POH	EX. OVERHEAD POWERLINE
-1070-	EX. INDEX CONTOUR LINE
-1072-	EX. INTERVAL CONTOUR LINE
---	EX. PAVED ROAD
---	EX. GRAVEL ROAD
---	EX. WETLAND
---	EX. TRAVEL PATH
●	FOUND MOUNUMENT
○	EX. POWER POLE
EX.	EXISTING
S/B	SETBACK
1.00%	EX. GROUND GRADE

Designed:	BCV	
Checked:	ADC	
Drawn:	BCV	
Record Drawing by/date:		
Revisions:		
#	DATE	DESCRIPTION

Prepared for:

GERONIMO ENERGY
 Geronimo Energy,
 7650 Edinborough Way, Suite 725
 Edina, MN 55435

KEY MAP

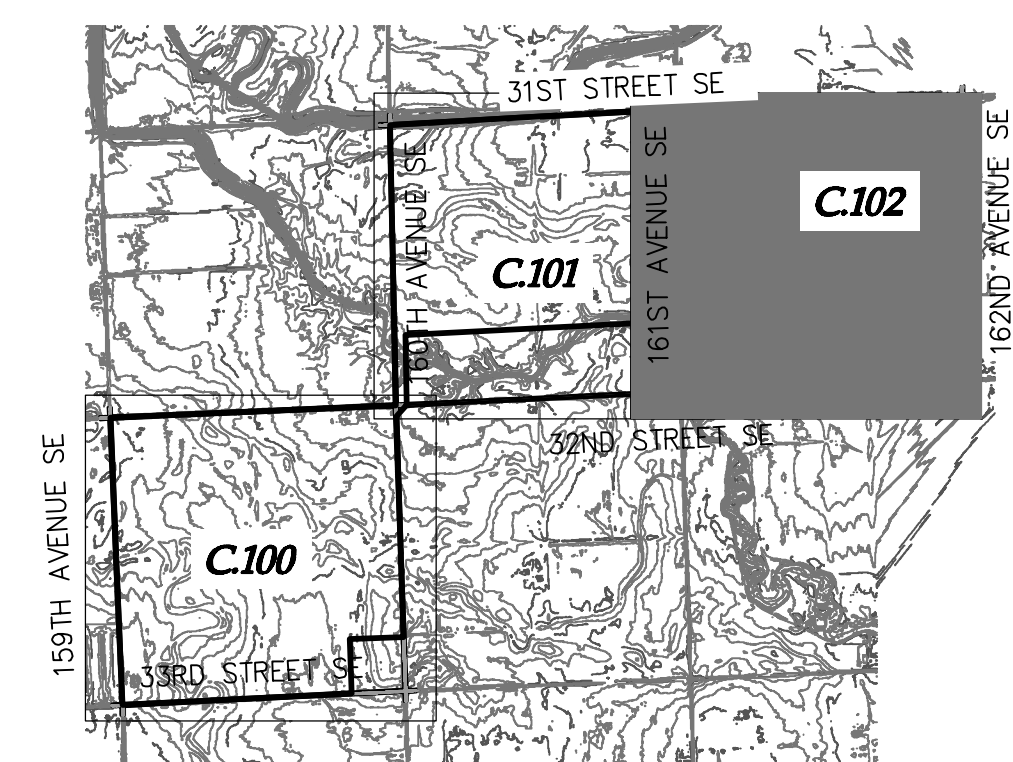

Harmony Solar ND, LLC
 Cass County, ND

Existing Conditions - 3

Issued for Permit
 Not For Construction

Date: 06/25/18
 Drawing No: C.102

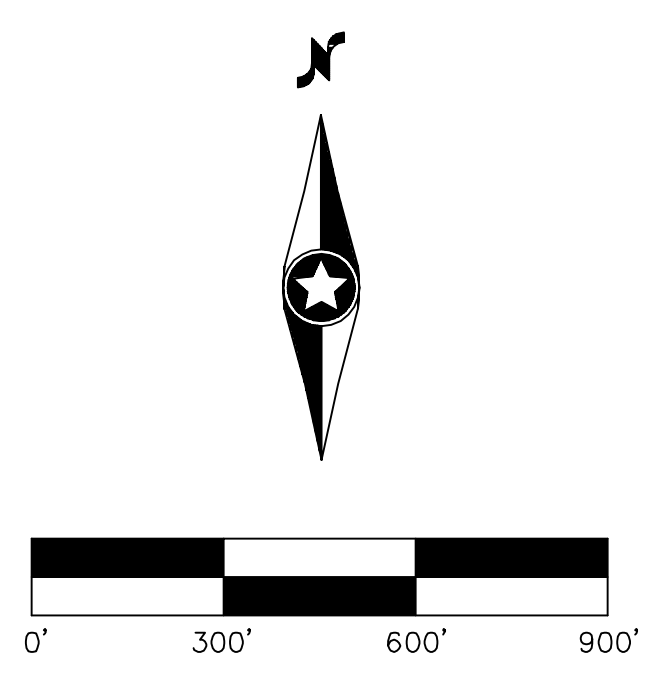

Designed:	BCV
Checked:	ADC
Drawn:	BCV

Record Drawing by/date:

Revisions #	DATE	DESCRIPTION

Prepared for:



Geronimo Energy,
 7650 Edinborough Way, Suite 725
 Edina, MN 55435

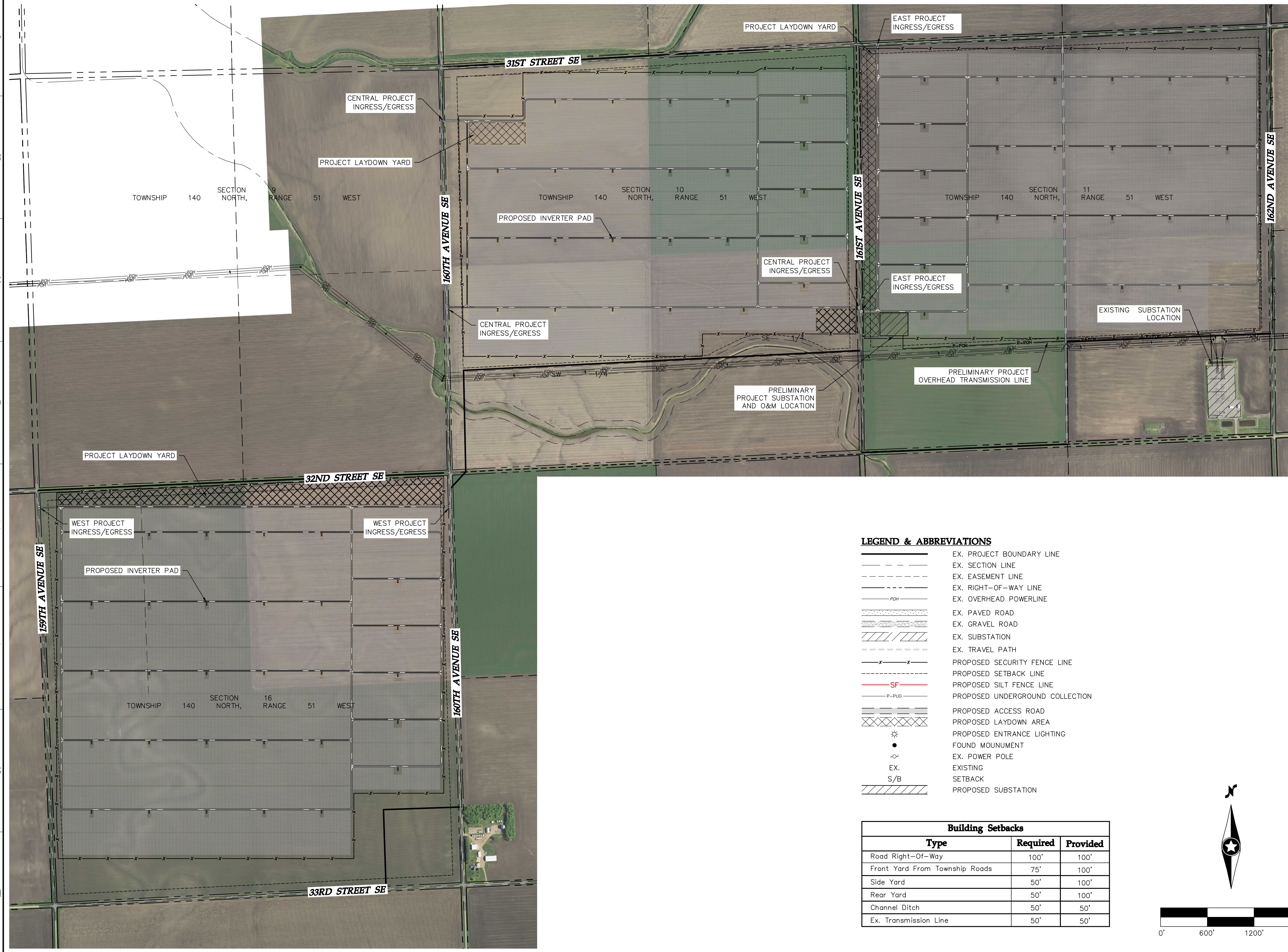

LEGEND & ABBREVIATIONS

	EX. PROJECT BOUNDARY LINE
	EX. SECTION LINE
	EX. EASEMENT LINE
	EX. RIGHT-OF-WAY LINE
	EX. OVERHEAD POWERLINE
	EX. PAVED ROAD
	EX. GRAVEL ROAD
	EX. SUBSTATION
	EX. TRAVEL PATH
	PROPOSED SECURITY FENCE LINE
	PROPOSED SETBACK LINE
	PROPOSED SILT FENCE LINE
	PROPOSED UNDERGROUND COLLECTION
	PROPOSED ACCESS ROAD
	PROPOSED LAYDOWN AREA
	PROPOSED ENTRANCE LIGHTING
	FOUND MOUNDMENT
	EX. POWER POLE
	EXISTING
	SETBACK
	PROPOSED SUBSTATION

Building Setbacks

Type	Required	Provided
Road Right-Of-Way	100'	100'
Front Yard From Township Roads	75'	100'
Side Yard	50'	100'
Rear Yard	50'	100'
Channel Ditch	50'	50'
Ex. Transmission Line	50'	50'

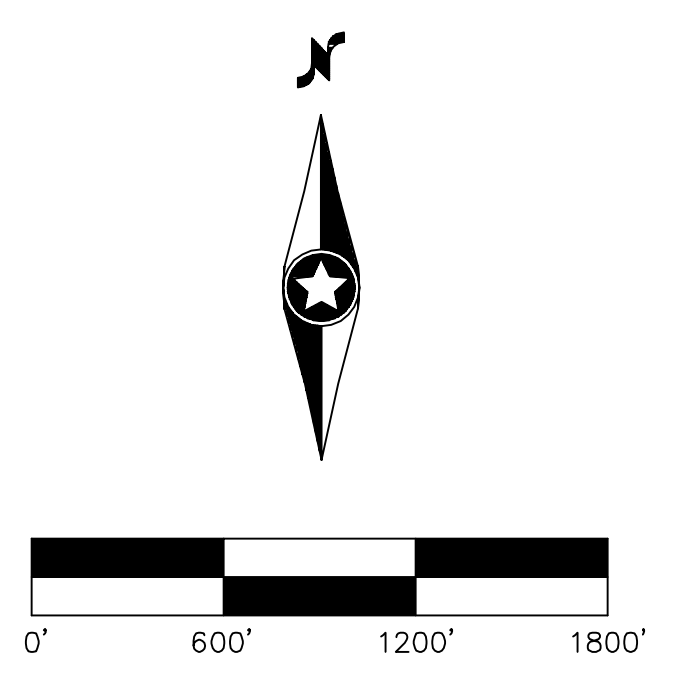

Harmony Solar ND, LLC
 Cass County, ND

Overall Site Plan

Issued for Permit
 Not For Construction

Date: 06/25/18
 Drawing No: C.200

LEGEND & ABBREVIATIONS

	EX. PROJECT BOUNDARY LINE
	EX. SECTION LINE
	EX. EASEMENT LINE
	EX. RIGHT-OF-WAY LINE
	EX. OVERHEAD POWERLINE
	EX. INDEX CONTOUR LINE
	EX. INTERVAL CONTOUR LINE
	EX. WETLAND
	EX. PAVED ROAD
	EX. GRAVEL ROAD
	EX. TRAVEL PATH
	PROPOSED SECURITY FENCE LINE
	PROPOSED SETBACK LINE
	PROPOSED SILT FENCE LINE
	PROPOSED OVERHEAD LINE
	PROPOSED ACCESS ROAD
	PROPOSED LAYDOWN AREA
	PROPOSED TOP-SOIL BERM LINE
	PROPOSED LAYDOWN AREA
	PROPOSED ENTRANCE LIGHTING
	EXISTING
	SETBACK

GENERAL NOTES:

1. THE PROPOSED PROJECT IS NOT ANTICIPATED TO HAVE MAJOR GRADING ACTIVITIES FOR THE CONSTRUCTION OF THE PROJECT.
2. MINOR SURFACE SMOOTHING MAY OCCUR FOR SOLAR PANEL INSTALLATION.
3. CONTRACTOR SHALL INSTALL ALL PERIMETER EROSION AND SEDIMENT CONTROL DEVICES PRIOR TO UPSLOPE DISTURBANCE ACTIVITIES.
4. SITE PREPARATION INCLUDES BUT IS NOT LIMITED TO CLEARING/GRUBBING, MINOR GRADING, COMPACTION, MOWING OF VEGETATION, AND RESTABILIZATION OF DISTURBED AREA.
5. ACCESS ROADS WILL BE CONSTRUCTED TO MATCH THE SURROUNDING EXISTING GROUND ELEVATIONS TO ALLOW THE CONTINUATION OF DRAINAGE PATTERNS.
6. OVERALL DRAINAGE PATTERNS WILL NOT BE ALTERED WITH SOLAR DEVELOPMENT.
7. A TEMPORARY STORAGE POND WILL BE REQUIRED DURING THE DURATION OF CONSTRUCTION IN ACCORDANCE TO PROJECT SWPPP REQUIREMENTS.

Designed: BCV

Checked: ADC

Drawn: BCV

Record Drawing by/date:

Revisions:

#	DATE	DESCRIPTION

Prepared for:

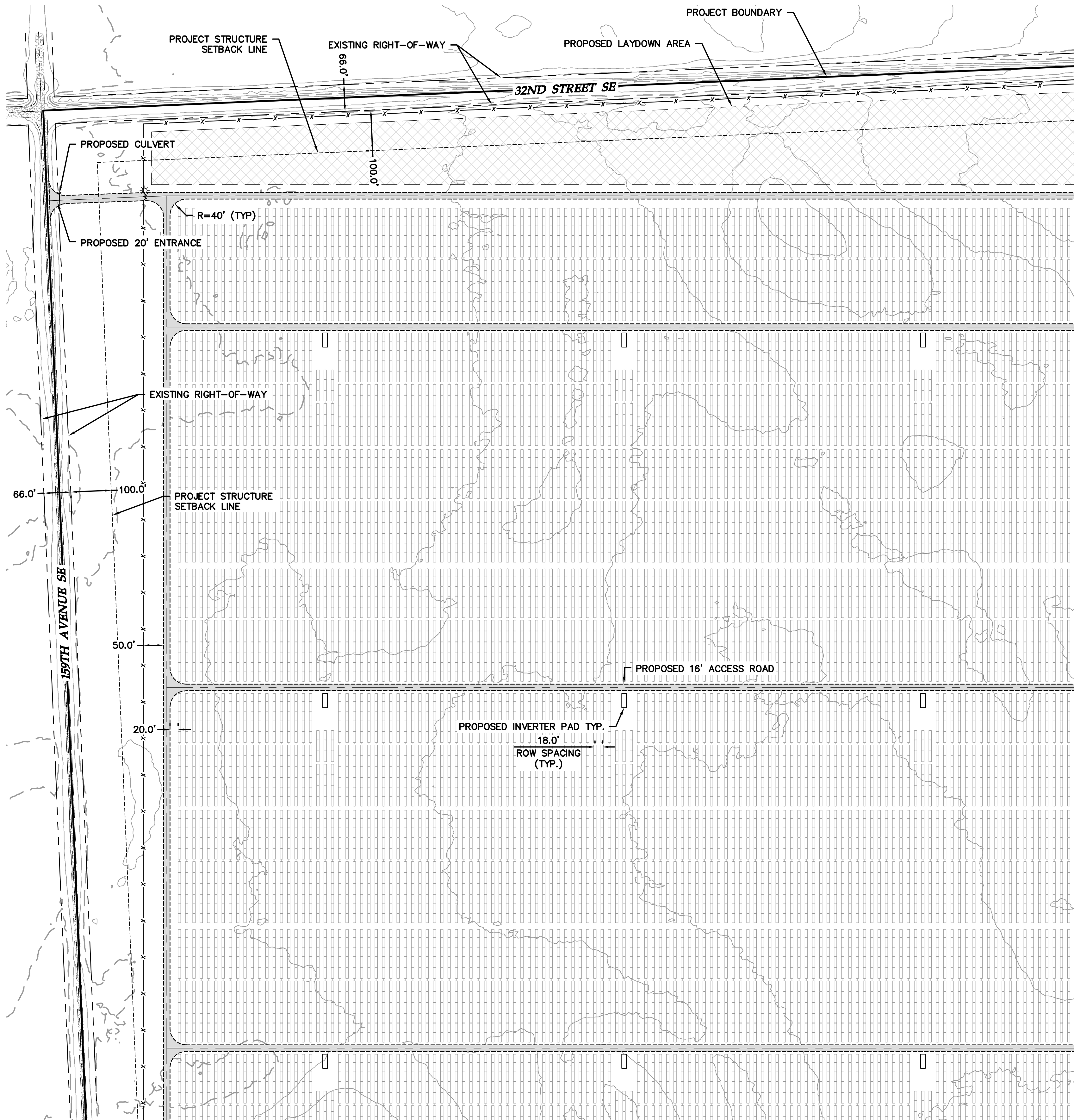

SEE SHEET C.301

SEE SHEET C.302

KEY MAP

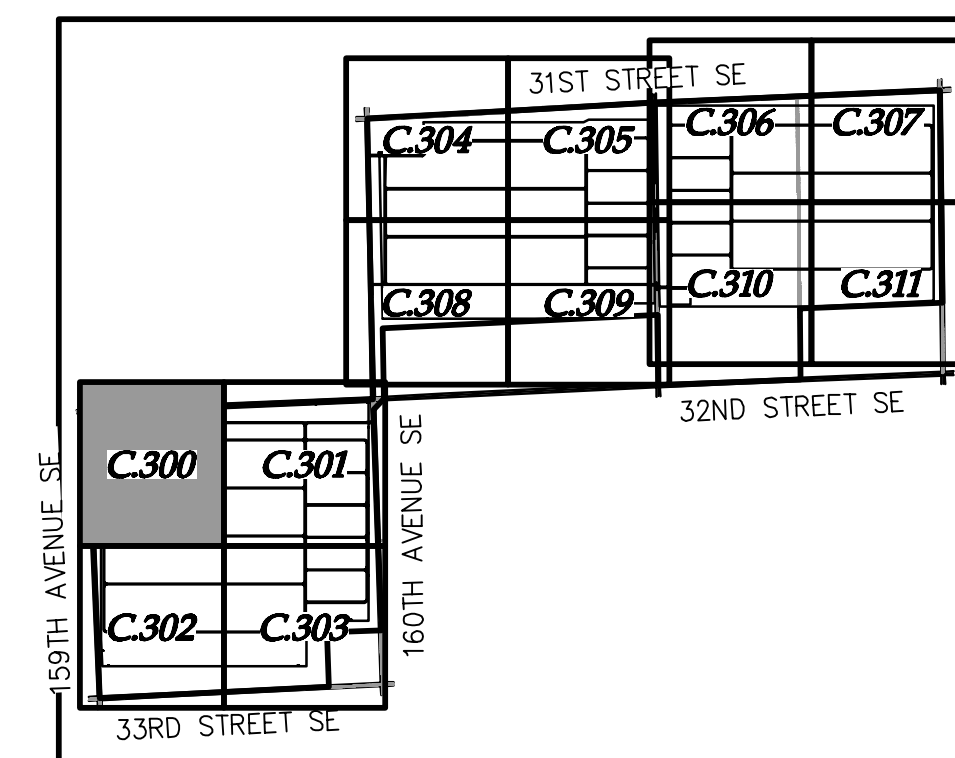

**Harmony Solar
ND, LLC**

Cass County, ND

Site Plan - 1

Issued for Permit
Not For Construction

Date: 06/25/18

Drawing No: C.300

SEE SHEET C.308

LEGEND & ABBREVIATIONS

	EX. PROJECT BOUNDARY LINE
	EX. SECTION LINE
	EX. EASEMENT LINE
	EX. RIGHT-OF-WAY LINE
	EX. OVERHEAD POWERLINE
	EX. INDEX CONTOUR LINE
	EX. INTERVAL CONTOUR LINE
	EX. WETLAND
	EX. PAVED ROAD
	EX. GRAVEL ROAD
	EX. TRAVEL PATH
	PROPOSED SECURITY FENCE LINE
	PROPOSED SETBACK LINE
	PROPOSED SILT FENCE LINE
	PROPOSED OVERHEAD LINE
	PROPOSED ACCESS ROAD
	PROPOSED LAYDOWN AREA
	PROPOSED TOP-SOIL BERM LINE
	PROPOSED LAYDOWN AREA
	PROPOSED ENTRANCE LIGHTING
	EX. EXISTING
	S/B SETBACK

GENERAL NOTES:

1. THE PROPOSED PROJECT IS NOT ANTICIPATED TO HAVE MAJOR GRADING ACTIVITIES FOR THE CONSTRUCTION OF THE PROJECT.
2. MINOR SURFACE SMOOTHING MAY OCCUR FOR SOLAR PANEL INSTALLATION.
3. CONTRACTOR SHALL INSTALL ALL PERIMETER EROSION AND SEDIMENT CONTROL DEVICES PRIOR TO UPSLOPE DISTURBANCE ACTIVITIES.
4. SITE PREPARATION INCLUDES BUT IS NOT LIMITED TO CLEARING/GRUBBING, MINOR GRADING, COMPACTION, MOWING OF VEGETATION, AND RESTABILIZATION OF DISTURBED AREA.
5. ACCESS ROADS WILL BE CONSTRUCTED TO MATCH THE SURROUNDING EXISTING GROUND ELEVATIONS TO ALLOW THE CONTINUATION OF DRAINAGE PATTERNS.
6. OVERALL DRAINAGE PATTERNS WILL NOT BE ALTERED WITH SOLAR DEVELOPMENT.
7. A TEMPORARY STORAGE POND WILL BE REQUIRED DURING THE DURATION OF CONSTRUCTION IN ACCORDANCE TO PROJECT SWPPP REQUIREMENTS.

KEY MAP

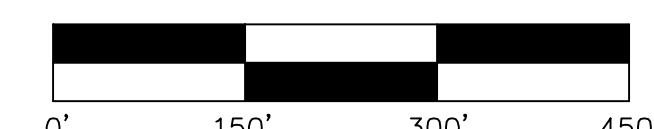
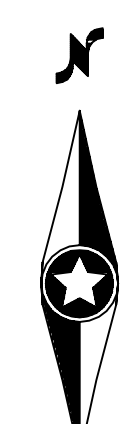
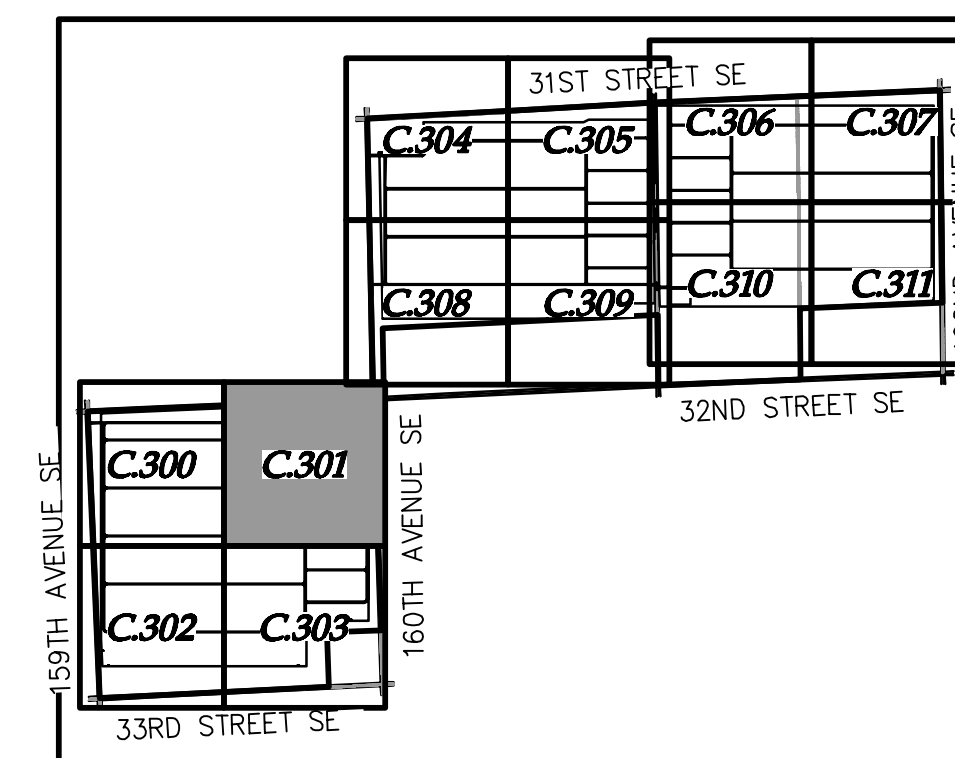

Westwood

Phone (952) 937-5150 12701 Whitewater Drive, Suite #300
 Fax (952) 937-5822 Minneapolis, MN 55443
 Toll Free (888) 937-5150 westwoods.com
 Westwood Professional Services, Inc.

Designed: **BCV**

Checked: **ADC**

Drawn: **BCV**

Record Drawing by/date:

Revisions:

#	DATE	DESCRIPTION

Prepared for:



Geronomo Energy,
 7650 Edinborough Way, Suite 725
 Edina, MN 55435

**Harmony Solar
 ND, LLC**

Cass County, ND

Site Plan - 2

Issued for Permit
 Not For Construction

Date: **06/25/18**

Drawing No: **C.301**

SEE SHEET C.300

SEE SHEET C.303



SEE SHEET C.303

LEGEND & ABBREVIATIONS

---	EX. PROJECT BOUNDARY LINE
---	EX. SECTION LINE
---	EX. EASEMENT LINE
---	EX. RIGHT-OF-WAY LINE
---	EX. OVERHEAD POWERLINE
---	EX. INDEX CONTOUR LINE
---	EX. INTERVAL CONTOUR LINE
---	EX. WETLAND
---	EX. PAVED ROAD
---	EX. GRAVEL ROAD
---	EX. TRAVEL PATH
---	PROPOSED SECURITY FENCE LINE
---	PROPOSED SETBACK LINE
---	PROPOSED SILT FENCE LINE
---	PROPOSED OVERHEAD LINE
---	PROPOSED ACCESS ROAD
---	PROPOSED LAYDOWN AREA
---	PROPOSED TOP-SOIL BERM LINE
---	PROPOSED LAYDOWN AREA
---	PROPOSED ENTRANCE LIGHTING
---	EX. EXISTING
---	S/B SETBACK

GENERAL NOTES:

1. THE PROPOSED PROJECT IS NOT ANTICIPATED TO HAVE MAJOR GRADING ACTIVITIES FOR THE CONSTRUCTION OF THE PROJECT.
2. MINOR SURFACE SMOOTHING MAY OCCUR FOR SOLAR PANEL INSTALLATION.
3. CONTRACTOR SHALL INSTALL ALL PERIMETER EROSION AND SEDIMENT CONTROL DEVICES PRIOR TO UPSLOPE DISTURBANCE ACTIVITIES.
4. SITE PREPARATION INCLUDES BUT IS NOT LIMITED TO CLEARING/GRUBBING, MINOR GRADING, COMPACTION, MOWING OF VEGETATION, AND RESTABILIZATION OF DISTURBED AREA.
5. ACCESS ROADS WILL BE CONSTRUCTED TO MATCH THE SURROUNDING EXISTING GROUND ELEVATIONS TO ALLOW THE CONTINUATION OF DRAINAGE PATTERNS.
6. OVERALL DRAINAGE PATTERNS WILL NOT BE ALTERED WITH SOLAR DEVELOPMENT.
7. A TEMPORARY STORAGE POND WILL BE REQUIRED DURING THE DURATION OF CONSTRUCTION IN ACCORDANCE TO PROJECT SWPPP REQUIREMENTS.

KEY MAP

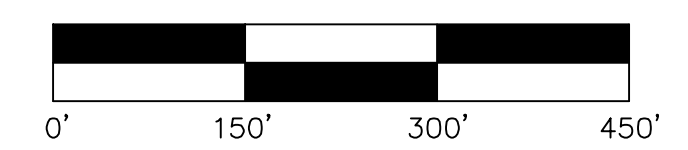
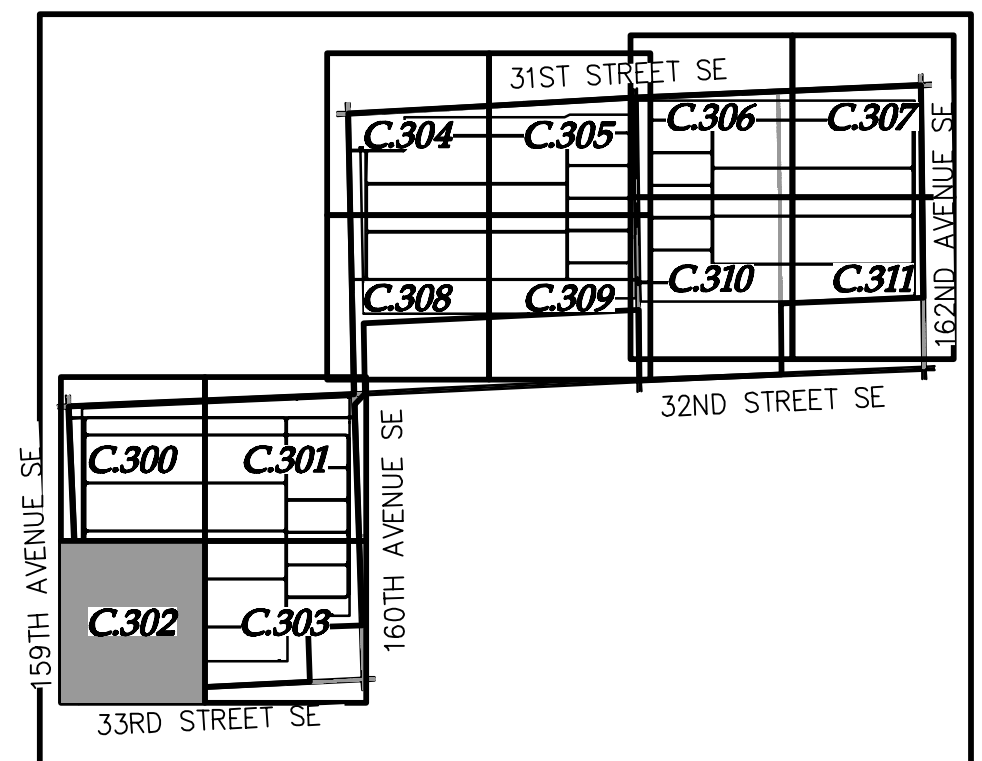

Westwood

Phone (952) 937-5150 12701 Whitewater Drive, Suite #300
 Fax (952) 937-5822 Minneapolis, MN 55443
 Toll Free (888) 937-5150 westwoodps.com
 Westwood Professional Services, Inc.

Designed: BCV
Checked: ADC
Drawn: BCV

Record Drawing by/date:

Revisions #	DATE	DESCRIPTION

Prepared for:

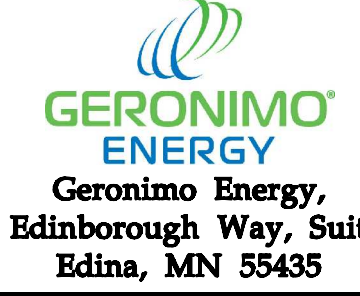

Harmony Solar ND, LLC

Cass County, ND

Site Plan - 3

Issued for Permit
 Not For Construction

Date: 06/25/18
 Drawing No: C.302

LEGEND & ABBREVIATIONS

	EX. PROJECT BOUNDARY LINE
	EX. SECTION LINE
	EX. EASEMENT LINE
	EX. RIGHT-OF-WAY LINE
	EX. OVERHEAD POWERLINE
	EX. INDEX CONTOUR LINE
	EX. INTERVAL CONTOUR LINE
	EX. WETLAND
	EX. PAVED ROAD
	EX. GRAVEL ROAD
	EX. TRAVEL PATH
	PROPOSED SECURITY FENCE LINE
	PROPOSED SETBACK LINE
	PROPOSED SILT FENCE LINE
	PROPOSED OVERHEAD LINE
	PROPOSED ACCESS ROAD
	PROPOSED LAYDOWN AREA
	PROPOSED TOP-SOIL BERM LINE
	PROPOSED LAYDOWN AREA
	PROPOSED ENTRANCE LIGHTING
	EXISTING
	SETBACK

GENERAL NOTES:

1. THE PROPOSED PROJECT IS NOT ANTICIPATED TO HAVE MAJOR GRADING ACTIVITIES FOR THE CONSTRUCTION OF THE PROJECT.
2. MINOR SURFACE SMOOTHING MAY OCCUR FOR SOLAR PANEL INSTALLATION.
3. CONTRACTOR SHALL INSTALL ALL PERIMETER EROSION AND SEDIMENT CONTROL DEVICES PRIOR TO UPSLOPE DISTURBANCE ACTIVITIES.
4. SITE PREPARATION INCLUDES BUT IS NOT LIMITED TO CLEARING/GRUBBING, MINOR GRADING, COMPACTION, MOWING OF VEGETATION, AND RESTABILIZATION OF DISTURBED AREA.
5. ACCESS ROADS WILL BE CONSTRUCTED TO MATCH THE SURROUNDING EXISTING GROUND ELEVATIONS TO ALLOW THE CONTINUATION OF DRAINAGE PATTERNS.
6. OVERALL DRAINAGE PATTERNS WILL NOT BE ALTERED WITH SOLAR DEVELOPMENT.
7. A TEMPORARY STORAGE POND WILL BE REQUIRED DURING THE DURATION OF CONSTRUCTION IN ACCORDANCE TO PROJECT SWPPP REQUIREMENTS.

Designed:	BCV
Checked:	ADC
Drawn:	BCV

Record Drawing by/date:

Revisions:	DATE	DESCRIPTION

Prepared for:

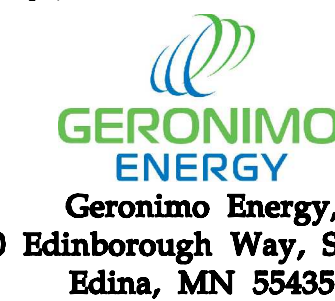

KEY MAP

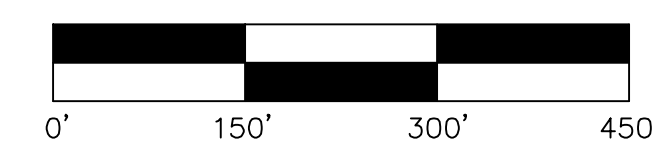
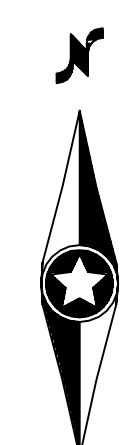
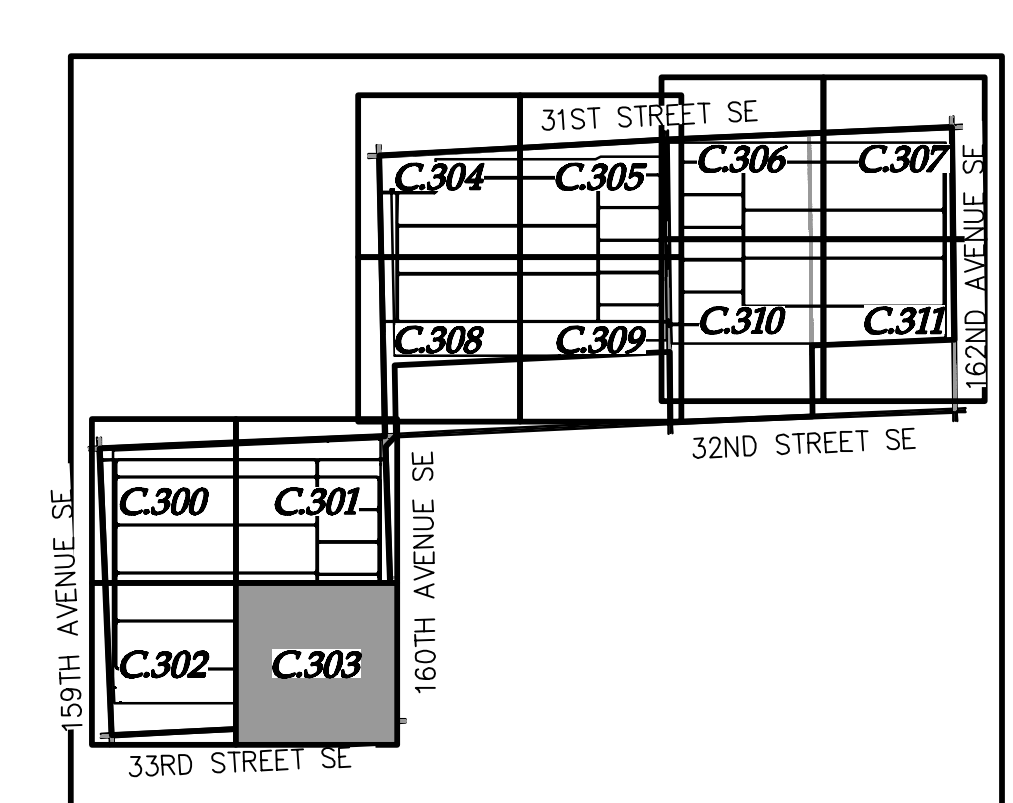

**Harmony Solar
ND, LLC**
Cass County, ND

Site Plan - 4

Issued for Permit
Not For Construction

Date: 06/25/18
Drawing No: C.303

LEGEND & ABBREVIATIONS

	EX. PROJECT BOUNDARY LINE
	EX. SECTION LINE
	EX. EASEMENT LINE
	EX. RIGHT-OF-WAY LINE
	EX. OVERHEAD POWERLINE
	EX. INDEX CONTOUR LINE
	EX. INTERVAL CONTOUR LINE
	EX. WETLAND
	EX. PAVED ROAD
	EX. GRAVEL ROAD
	EX. TRAVEL PATH
	PROPOSED SECURITY FENCE LINE
	PROPOSED SETBACK LINE
	PROPOSED SILT FENCE LINE
	PROPOSED OVERHEAD LINE
	PROPOSED ACCESS ROAD
	PROPOSED SOLAR ARRAY
	PROPOSED LAYDOWN AREA
	PROPOSED TOP SOIL BERM LINE
	PROPOSED ENTRANCE LIGHTING
	EXISTING
	SETBACK
	FUTURE TRANSMISSION LINE EASEMENT

GENERAL NOTES:

1. THE PROPOSED PROJECT IS NOT ANTICIPATED TO HAVE MAJOR GRADING ACTIVITIES FOR THE CONSTRUCTION OF THE PROJECT.
2. MINOR SURFACE SMOOTHING MAY OCCUR FOR SOLAR PANEL INSTALLATION.
3. CONTRACTOR SHALL INSTALL ALL PERIMETER EROSION AND SEDIMENT CONTROL DEVICES PRIOR TO UPSLOPE DISTURBANCE ACTIVITIES.
4. SITE PREPARATION INCLUDES BUT IS NOT LIMITED TO CLEARING/GRUBBING, MINOR GRADING, COMPACTION, MOWING OF VEGETATION, AND RESTABILIZATION OF DISTURBED AREA.
5. ACCESS ROADS WILL BE CONSTRUCTED TO MATCH THE SURROUNDING EXISTING GROUND ELEVATIONS TO ALLOW THE CONTINUATION OF DRAINAGE PATTERNS.
6. OVERALL DRAINAGE PATTERNS WILL NOT BE ALTERED WITH SOLAR DEVELOPMENT.
7. A TEMPORARY STORAGE POND WILL BE REQUIRED DURING THE DURATION OF CONSTRUCTION IN ACCORDANCE TO PROJECT SWPPP REQUIREMENTS.

KEY MAP

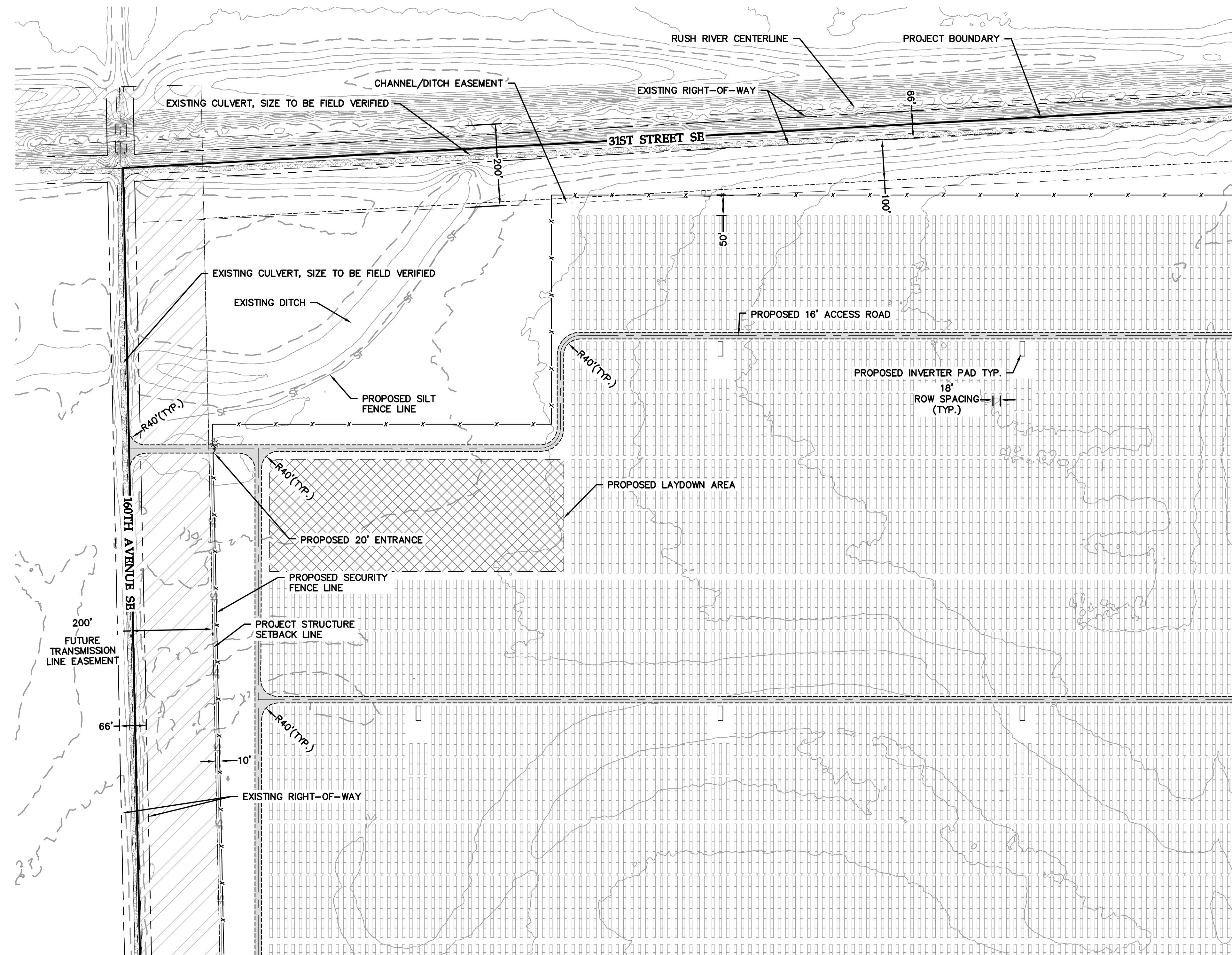
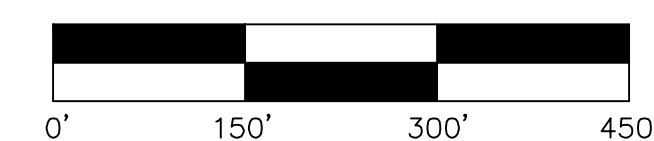
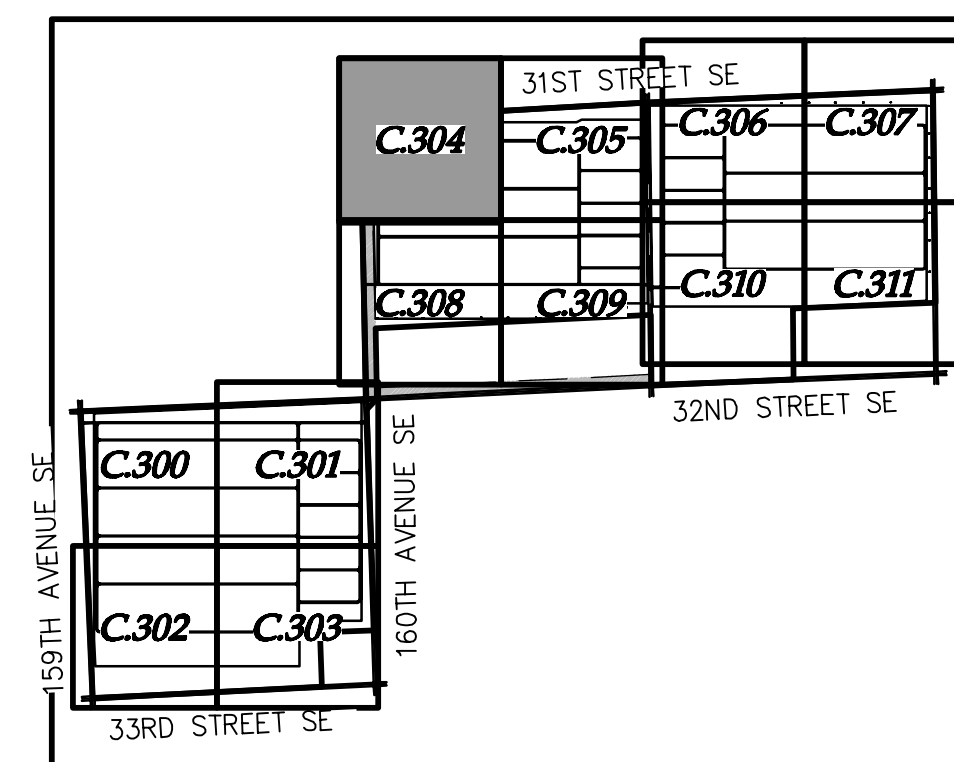

SEE SHEET C.305

SEE SHEET C.308

Designed:	BCV
Checked:	ADC
Drawn:	BCV

Record Drawing by/date:

Revisions:	DATE	DESCRIPTION

Prepared for:

 Geronimo Energy,
 7650 Edinborough Way, Suite 725
 Edina, MN 55435

**Harmony Solar
 ND, LLC**
 Cass County, ND

Site Plan - 5

Issued for Permit
 Not For Construction

Date: 06/25/18
 Drawing No: C.304

LEGEND & ABBREVIATIONS

	EX. PROJECT BOUNDARY LINE
	EX. SECTION LINE
	EX. EASEMENT LINE
	EX. RIGHT-OF-WAY LINE
	EX. OVERHEAD POWERLINE
	EX. INDEX CONTOUR LINE
	EX. INTERVAL CONTOUR LINE
	EX. WETLAND
	EX. PAVED ROAD
	EX. GRAVEL ROAD
	EX. TRAVEL PATH
	PROPOSED SECURITY FENCE LINE
	PROPOSED SETBACK LINE
	PROPOSED SILT FENCE LINE
	PROPOSED OVERHEAD LINE
	PROPOSED ACCESS ROAD
	PROPOSED SOLAR ARRAY
	PROPOSED LAYDOWN AREA
	PROPOSED TOP SOIL BERM LINE
	PROPOSED LAYDOWN AREA
	PROPOSED ENTRANCE LIGHTING
	EXISTING
	SETBACK
	FUTURE TRANSMISSION LINE EASEMENT

GENERAL NOTES:

1. THE PROPOSED PROJECT IS NOT ANTICIPATED TO HAVE MAJOR GRADING ACTIVITIES FOR THE CONSTRUCTION OF THE PROJECT.
2. MINOR SURFACE SMOOTHING MAY OCCUR FOR SOLAR PANEL INSTALLATION.
3. CONTRACTOR SHALL INSTALL ALL PERIMETER EROSION AND SEDIMENT CONTROL DEVICES PRIOR TO UPSLOPE DISTURBANCE ACTIVITIES.
4. SITE PREPARATION INCLUDES BUT IS NOT LIMITED TO CLEARING/GRUBBING, MINOR GRADING, COMPACTION, MOWING OF VEGETATION, AND RESTABILIZATION OF DISTURBED AREA.
5. ACCESS ROADS WILL BE CONSTRUCTED TO MATCH THE SURROUNDING EXISTING GROUND ELEVATIONS TO ALLOW THE CONTINUATION OF DRAINAGE PATTERNS.
6. OVERALL DRAINAGE PATTERNS WILL NOT BE ALTERED WITH SOLAR DEVELOPMENT.
7. A TEMPORARY STORAGE POND WILL BE REQUIRED DURING THE DURATION OF CONSTRUCTION IN ACCORDANCE TO PROJECT SWPPP REQUIREMENTS.

KEY MAP

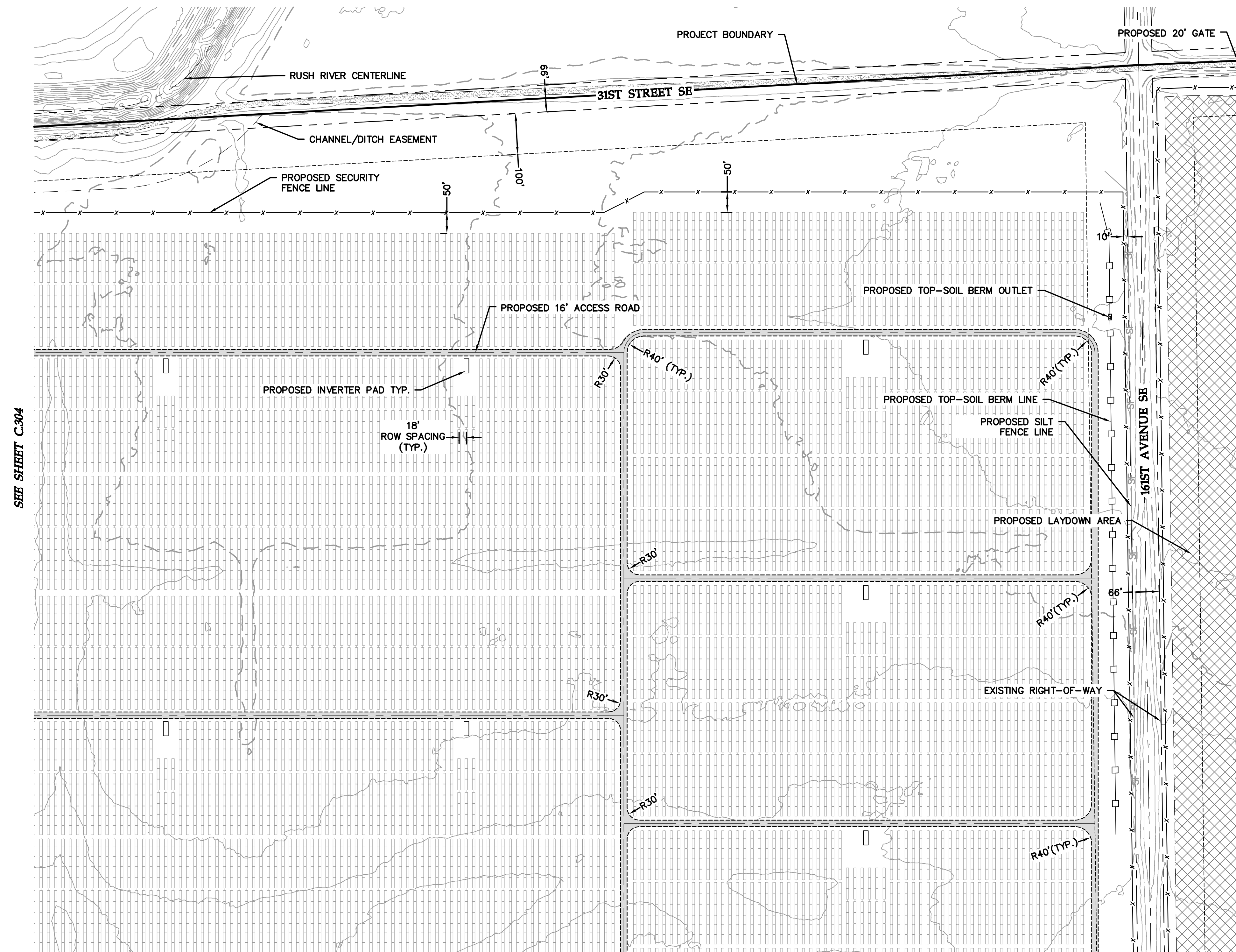
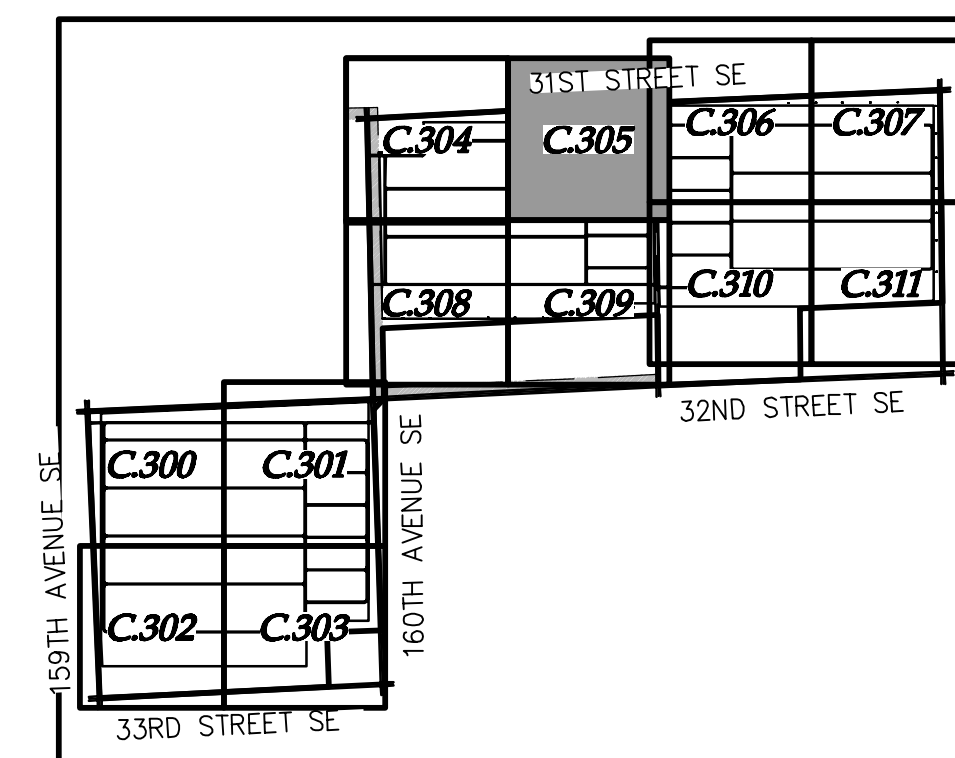

SEE SHEET C.304

SEE SHEET C.306

SEE SHEET C.309

Designed: BCV

Checked: ADC

Drawn: BCV

Record Drawing by/date:

Revisions: # DATE DESCRIPTION

Prepared for:



Geronomo Energy,
 7650 Edinborough Way, Suite 725
 Edina, MN 55435

**Harmony Solar
 ND, LLC**

Cass County, ND

Site Plan - 6

Issued for Permit
 Not For Construction

Date: 06/25/18

Drawing No: C.305

LEGEND & ABBREVIATIONS

	EX. PROJECT BOUNDARY LINE
	EX. SECTION LINE
	EX. EASEMENT LINE
	EX. RIGHT-OF-WAY LINE
	EX. OVERHEAD POWERLINE
	EX. INDEX CONTOUR LINE
	EX. INTERVAL CONTOUR LINE
	EX. WETLAND
	EX. PAVED ROAD
	EX. GRAVEL ROAD
	EX. TRAVEL PATH
	PROPOSED SECURITY FENCE LINE
	PROPOSED SETBACK LINE
	PROPOSED SILT FENCE LINE
	PROPOSED OVERHEAD LINE
	PROPOSED ACCESS ROAD
	PROPOSED SOLAR ARRAY
	PROPOSED LAYDOWN AREA
	PROPOSED TOP SOIL BERM LINE
	PROPOSED LAYDOWN AREA
	PROPOSED ENTRANCE LIGHTING
	EXISTING
	SETBACK
	FUTURE TRANSMISSION LINE EASEMENT

GENERAL NOTES:

1. THE PROPOSED PROJECT IS NOT ANTICIPATED TO HAVE MAJOR GRADING ACTIVITIES FOR THE CONSTRUCTION OF THE PROJECT.
2. MINOR SURFACE SMOOTHING MAY OCCUR FOR SOLAR PANEL INSTALLATION.
3. CONTRACTOR SHALL INSTALL ALL PERIMETER EROSION AND SEDIMENT CONTROL DEVICES PRIOR TO UPSLOPE DISTURBANCE ACTIVITIES.
4. SITE PREPARATION INCLUDES BUT IS NOT LIMITED TO CLEARING/GRUBBING, MINOR GRADING, COMPACTION, MOWING OF VEGETATION, AND RESTABILIZATION OF DISTURBED AREA.
5. ACCESS ROADS WILL BE CONSTRUCTED TO MATCH THE SURROUNDING EXISTING GROUND ELEVATIONS TO ALLOW THE CONTINUATION OF DRAINAGE PATTERNS.
6. OVERALL DRAINAGE PATTERNS WILL NOT BE ALTERED WITH SOLAR DEVELOPMENT.
7. A TEMPORARY STORAGE POND WILL BE REQUIRED DURING THE DURATION OF CONSTRUCTION IN ACCORDANCE TO PROJECT SWPPP REQUIREMENTS.

KEY MAP

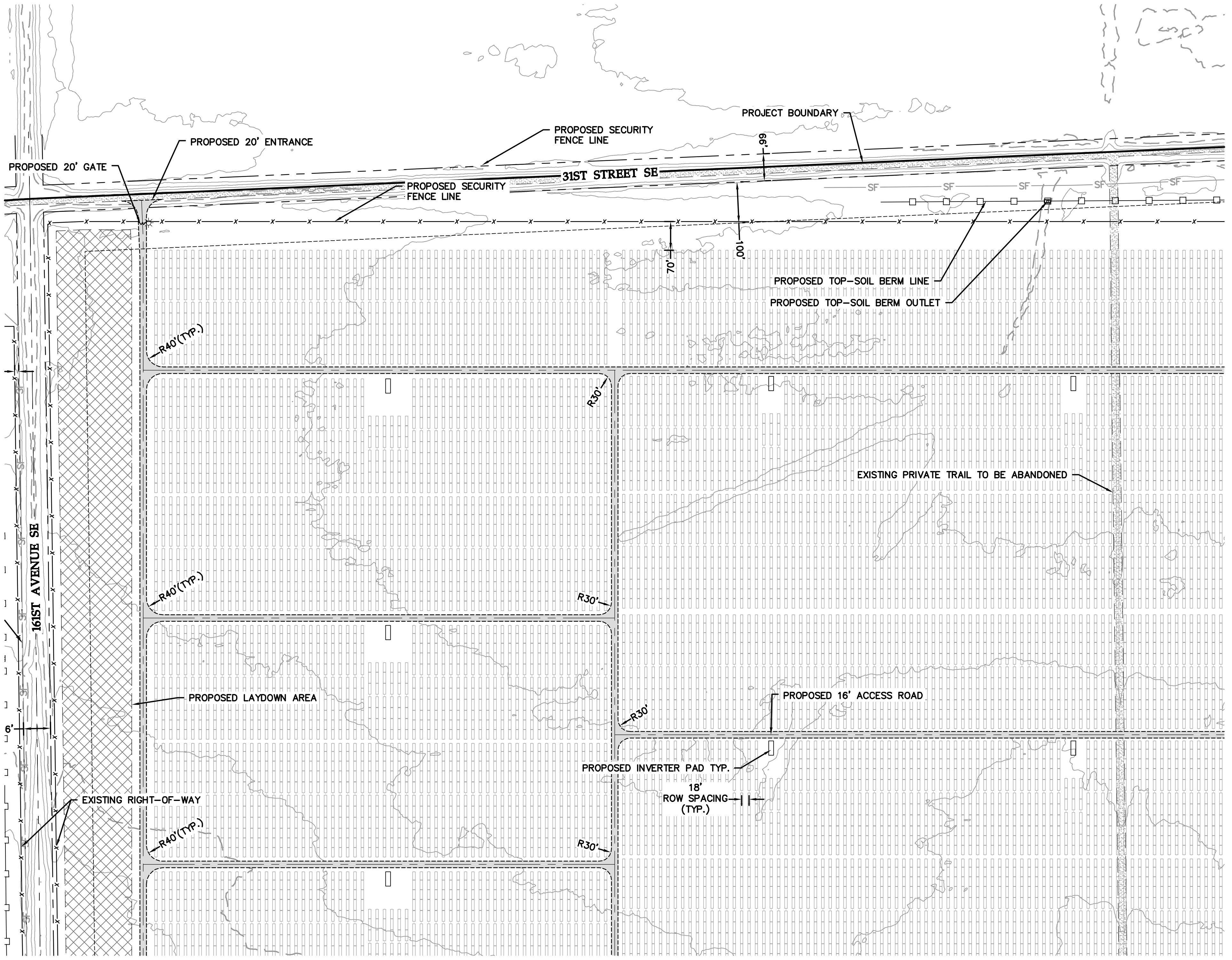
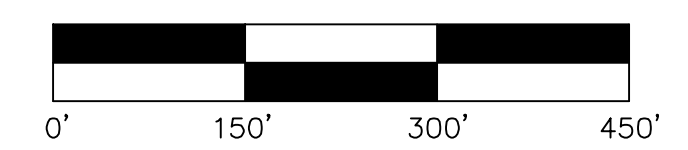
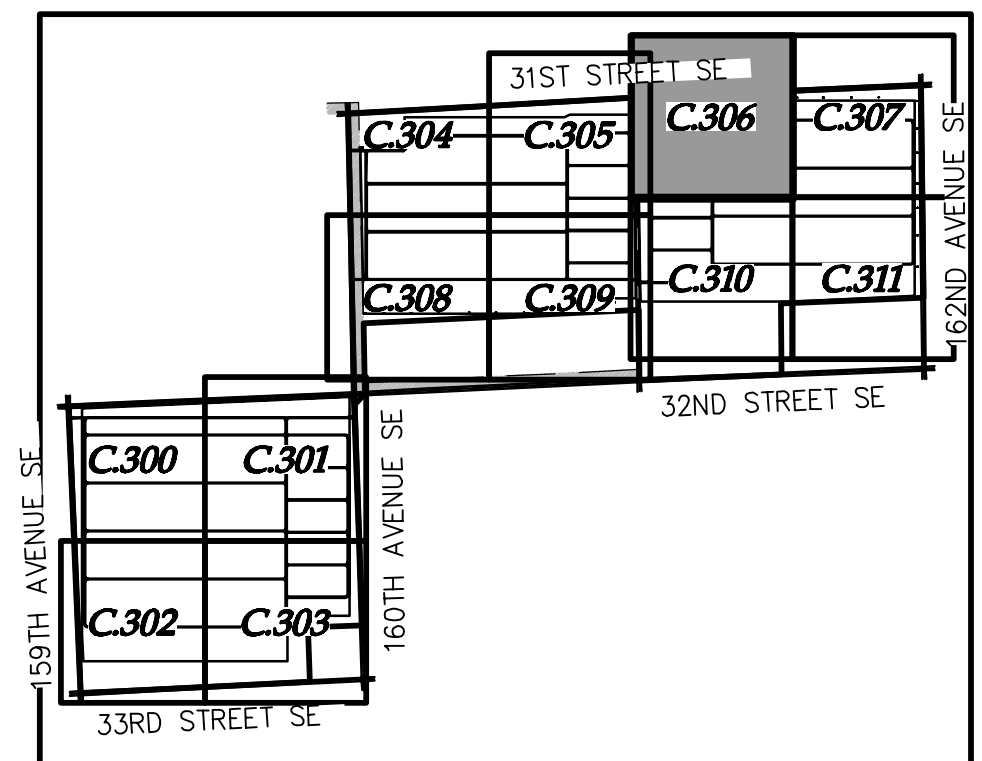

SEE SHEET C.305

SEE SHEET C.307

SEE SHEET C.310

Designed:	BCV
Checked:	ADC
Drawn:	BCV

Record Drawing by/date:

Revisions:	DATE	DESCRIPTION

Prepared for:

GERONIMO ENERGY
 Geronimo Energy,
 7650 Edinborough Way, Suite 725
 Edina, MN 55435

**Harmony Solar
 ND, LLC**
 Cass County, ND

Site Plan - 7

Issued for Permit
 Not For Construction

Date: 06/25/18
 Drawing No: C.306

LEGEND & ABBREVIATIONS

	EX. PROJECT BOUNDARY LINE
	EX. SECTION LINE
	EX. EASEMENT LINE
	EX. RIGHT-OF-WAY LINE
	EX. OVERHEAD POWERLINE
	EX. INDEX CONTOUR LINE
	EX. INTERVAL CONTOUR LINE
	EX. WETLAND
	EX. PAVED ROAD
	EX. GRAVEL ROAD
	EX. TRAVEL PATH
	PROPOSED SECURITY FENCE LINE
	PROPOSED SETBACK LINE
	PROPOSED SILT FENCE LINE
	PROPOSED OVERHEAD LINE
	PROPOSED ACCESS ROAD
	PROPOSED SOLAR ARRAY
	PROPOSED LAYDOWN AREA
	PROPOSED TOP SOIL BERM LINE
	PROPOSED LAYDOWN AREA
	PROPOSED ENTRANCE LIGHTING
	EXISTING
	SETBACK
	FUTURE TRANSMISSION LINE EASEMENT

GENERAL NOTES:

1. THE PROPOSED PROJECT IS NOT ANTICIPATED TO HAVE MAJOR GRADING ACTIVITIES FOR THE CONSTRUCTION OF THE PROJECT.
2. MINOR SURFACE SMOOTHING MAY OCCUR FOR SOLAR PANEL INSTALLATION.
3. CONTRACTOR SHALL INSTALL ALL PERIMETER EROSION AND SEDIMENT CONTROL DEVICES PRIOR TO UPSLOPE DISTURBANCE ACTIVITIES.
4. SITE PREPARATION INCLUDES BUT IS NOT LIMITED TO CLEARING/GRUBBING, MINOR GRADING, COMPACTION, MOWING OF VEGETATION, AND RESTABILIZATION OF DISTURBED AREA.
5. ACCESS ROADS WILL BE CONSTRUCTED TO MATCH THE SURROUNDING EXISTING GROUND ELEVATIONS TO ALLOW THE CONTINUATION OF DRAINAGE PATTERNS.
6. OVERALL DRAINAGE PATTERNS WILL NOT BE ALTERED WITH SOLAR DEVELOPMENT.
7. A TEMPORARY STORAGE POND WILL BE REQUIRED DURING THE DURATION OF CONSTRUCTION IN ACCORDANCE TO PROJECT SWPPP REQUIREMENTS.

Designed: **BCV**

Checked: **ADC**

Drawn: **BCV**

Record Drawing by/date:

Revisions:

#	DATE	DESCRIPTION

Prepared for:



Geronomo Energy,
 7650 Edinborough Way, Suite 725
 Edina, MN 55435

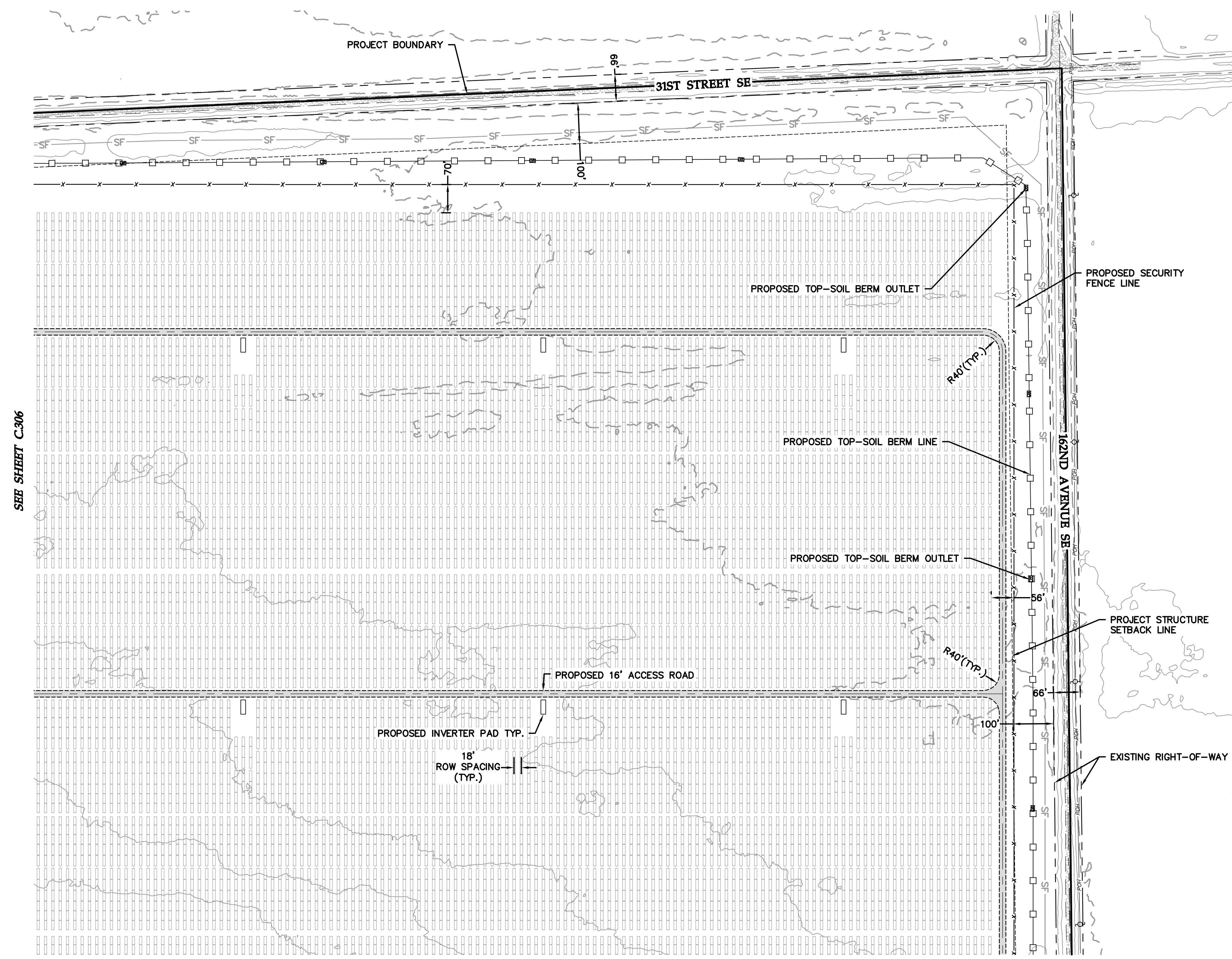

SEE SHEET C.306

SEE SHEET C.311

KEY MAP

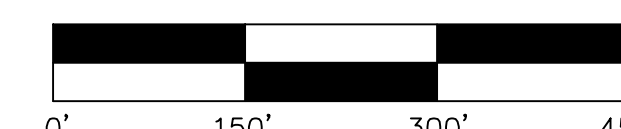
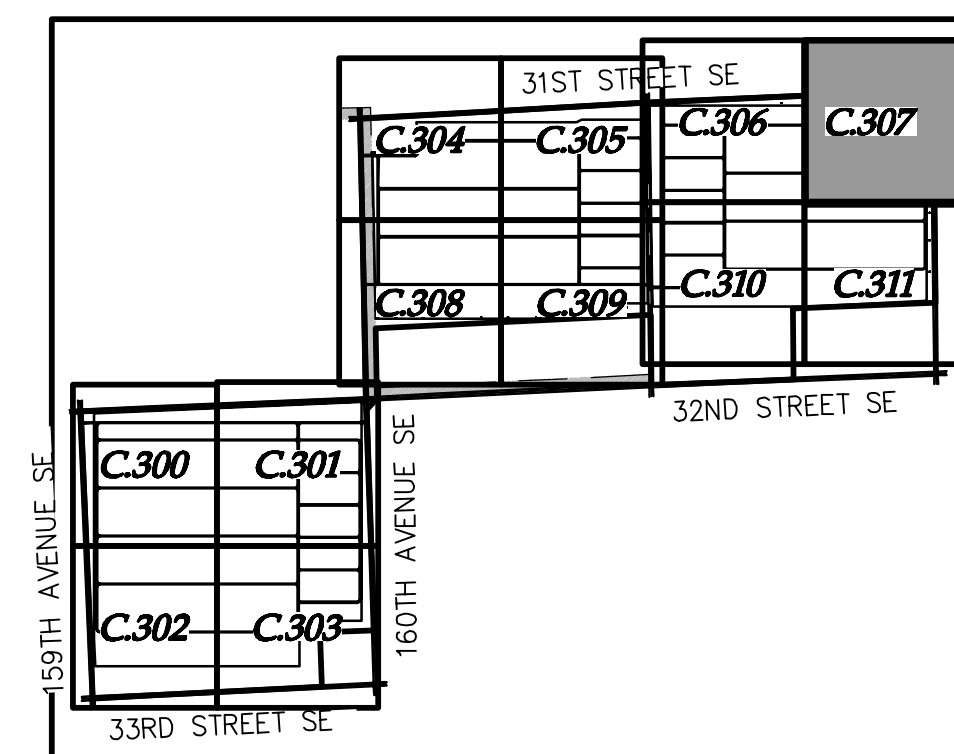

**Harmony Solar
 ND, LLC**
 Cass County, ND

Site Plan - 8

Issued for Permit
 Not For Construction

Date: **06/25/18**

Drawing No: **C.307**

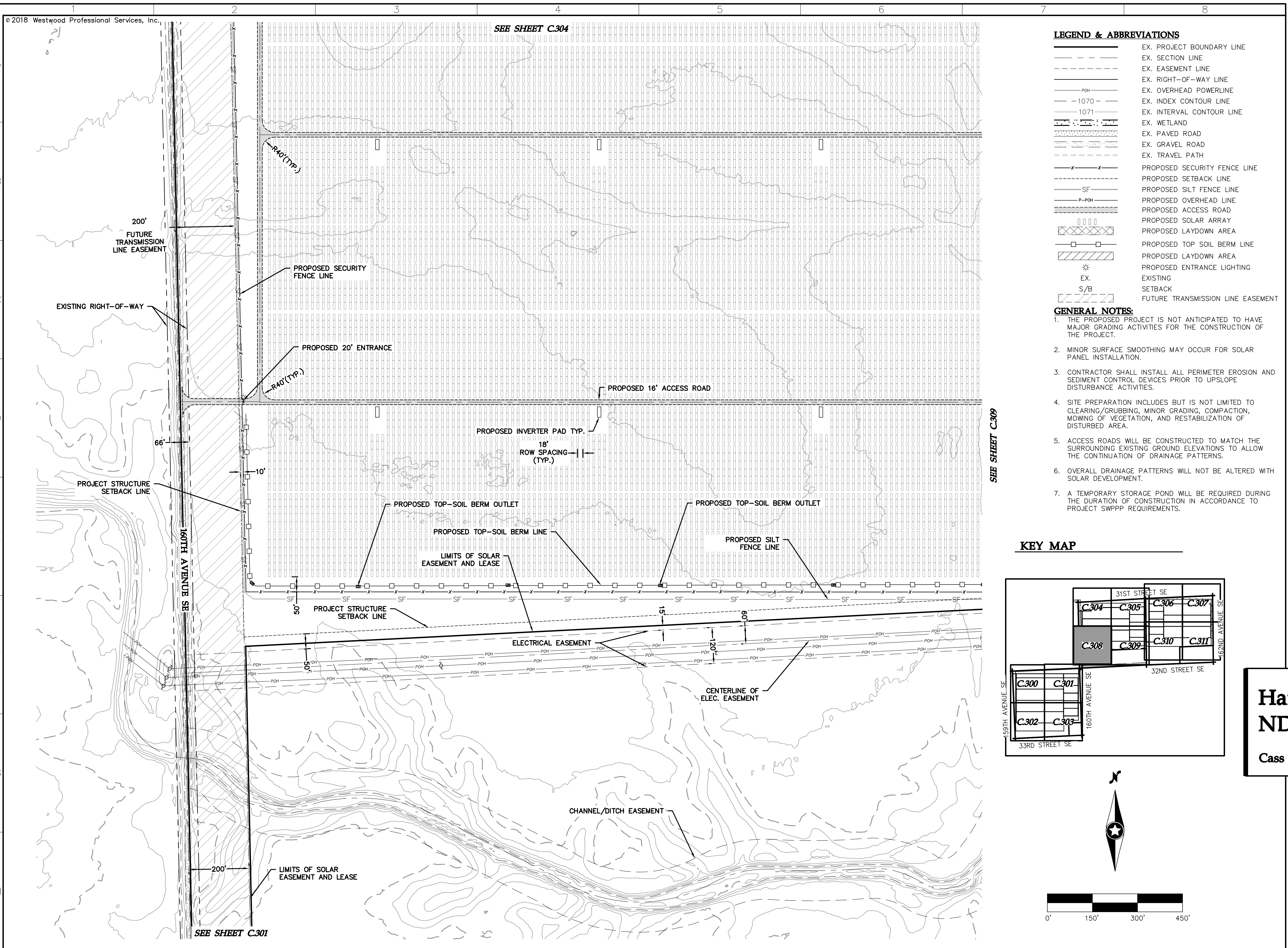

LEGEND & ABBREVIATIONS

	EX. PROJECT BOUNDARY LINE
	EX. SECTION LINE
	EX. EASEMENT LINE
	EX. RIGHT-OF-WAY LINE
	EX. OVERHEAD POWERLINE
	EX. INDEX CONTOUR LINE
	EX. INTERVAL CONTOUR LINE
	EX. WETLAND
	EX. PAVED ROAD
	EX. GRAVEL ROAD
	EX. TRAVEL PATH
	PROPOSED SECURITY FENCE LINE
	PROPOSED SETBACK LINE
	PROPOSED SILT FENCE LINE
	PROPOSED OVERHEAD LINE
	PROPOSED ACCESS ROAD
	PROPOSED SOLAR ARRAY
	PROPOSED LAYDOWN AREA
	PROPOSED TOP SOIL BERM LINE
	PROPOSED LAYDOWN AREA
	PROPOSED ENTRANCE LIGHTING
	EXISTING
	SETBACK
	FUTURE TRANSMISSION LINE EASEMENT

GENERAL NOTES:

1. THE PROPOSED PROJECT IS NOT ANTICIPATED TO HAVE MAJOR GRADING ACTIVITIES FOR THE CONSTRUCTION OF THE PROJECT.
2. MINOR SURFACE SMOOTHING MAY OCCUR FOR SOLAR PANEL INSTALLATION.
3. CONTRACTOR SHALL INSTALL ALL PERIMETER EROSION AND SEDIMENT CONTROL DEVICES PRIOR TO UPSLOPE DISTURBANCE ACTIVITIES.
4. SITE PREPARATION INCLUDES BUT IS NOT LIMITED TO CLEARING/GRUBBING, MINOR GRADING, COMPACTION, MOWING OF VEGETATION, AND RESTABILIZATION OF DISTURBED AREA.
5. ACCESS ROADS WILL BE CONSTRUCTED TO MATCH THE SURROUNDING EXISTING GROUND ELEVATIONS TO ALLOW THE CONTINUATION OF DRAINAGE PATTERNS.
6. OVERALL DRAINAGE PATTERNS WILL NOT BE ALTERED WITH SOLAR DEVELOPMENT.
7. A TEMPORARY STORAGE POND WILL BE REQUIRED DURING THE DURATION OF CONSTRUCTION IN ACCORDANCE TO PROJECT SWPPP REQUIREMENTS.

KEY MAP

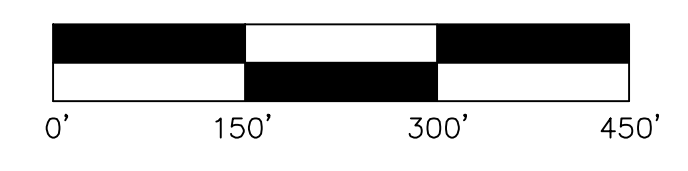
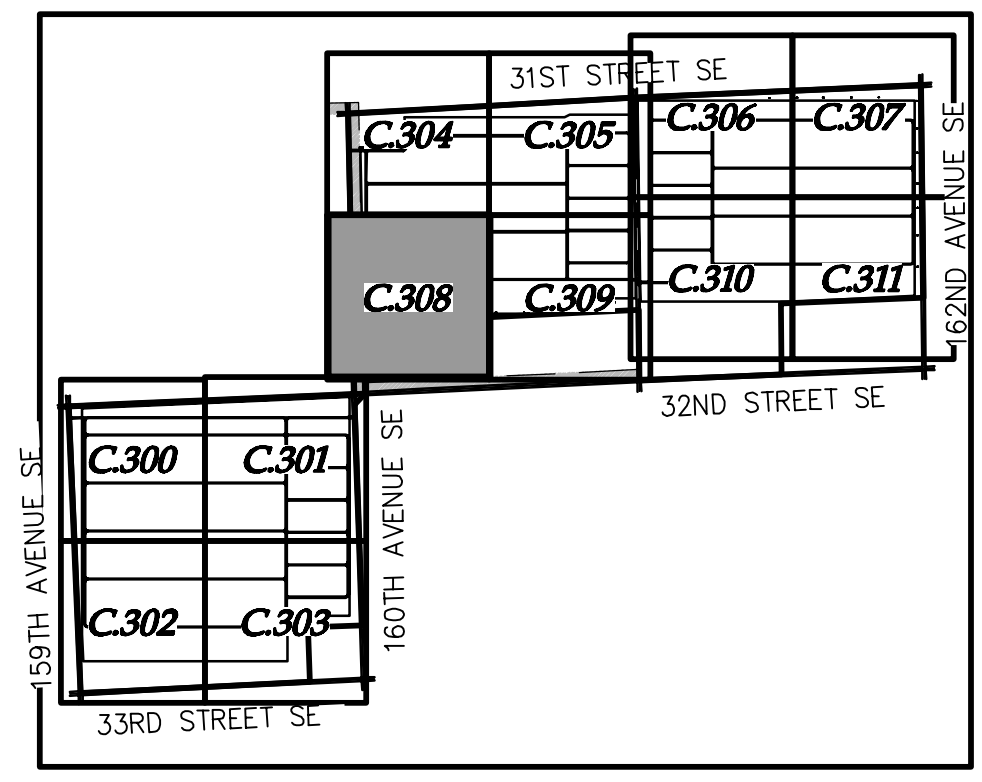

Westwood

Phone (952) 937-5150 12701 Whitewater Drive, Suite #300
 Fax (952) 937-5822 Minnetonka, MN 55343
 Toll Free (888) 937-5150 westwoods.com
 Westwood Professional Services, Inc.

Designed:	BCV
Checked:	ADC
Drawn:	BCV

Record Drawing by/date:

Revisions #	DATE	DESCRIPTION

Prepared for:



**Harmony Solar
 ND, LLC**
 Cass County, ND

Site Plan - 9

Issued for Permit
 Not For Construction

Date: 06/25/18
 Drawing No: C.308

LEGEND & ABBREVIATIONS

	EX. PROJECT BOUNDARY LINE
	EX. SECTION LINE
	EX. EASEMENT LINE
	EX. RIGHT-OF-WAY LINE
	EX. OVERHEAD POWERLINE
	EX. INDEX CONTOUR LINE
	EX. INTERVAL CONTOUR LINE
	EX. WETLAND
	EX. PAVED ROAD
	EX. GRAVEL ROAD
	EX. TRAVEL PATH
	PROPOSED SECURITY FENCE LINE
	PROPOSED SETBACK LINE
	PROPOSED SILT FENCE LINE
	PROPOSED OVERHEAD LINE
	PROPOSED ACCESS ROAD
	PROPOSED LAYDOWN AREA
	PROPOSED TOP SOIL BERM LINE
	PROPOSED LAYDOWN AREA
	PROPOSED ENTRANCE LIGHTING
	EXISTING
	SETBACK
	FUTURE TRANSMISSION LINE EASEMENT

GENERAL NOTES:

1. THE PROPOSED PROJECT IS NOT ANTICIPATED TO HAVE MAJOR GRADING ACTIVITIES FOR THE CONSTRUCTION OF THE PROJECT.
2. MINOR SURFACE SMOOTHING MAY OCCUR FOR SOLAR PANEL INSTALLATION.
3. CONTRACTOR SHALL INSTALL ALL PERIMETER EROSION AND SEDIMENT CONTROL DEVICES PRIOR TO UPSLOPE DISTURBANCE ACTIVITIES.
4. SITE PREPARATION INCLUDES BUT IS NOT LIMITED TO CLEARING/GRUBBING, MINOR GRADING, COMPACTION, MOWING OF VEGETATION, AND RESTABILIZATION OF DISTURBED AREA.
5. ACCESS ROADS WILL BE CONSTRUCTED TO MATCH THE SURROUNDING EXISTING GROUND ELEVATIONS TO ALLOW THE CONTINUATION OF DRAINAGE PATTERNS.
6. OVERALL DRAINAGE PATTERNS WILL NOT BE ALTERED WITH SOLAR DEVELOPMENT.
7. A TEMPORARY STORAGE POND WILL BE REQUIRED DURING THE DURATION OF CONSTRUCTION IN ACCORDANCE TO PROJECT SWPPP REQUIREMENTS.

Designed: BCV
 Checked: ADC
 Drawn: BCV

Record Drawing by/date:

Revisions #	DATE	DESCRIPTION

Prepared for:



GERONIMO ENERGY
 Geronimo Energy,
 7650 Edinborough Way, Suite 725
 Edina, MN 55435

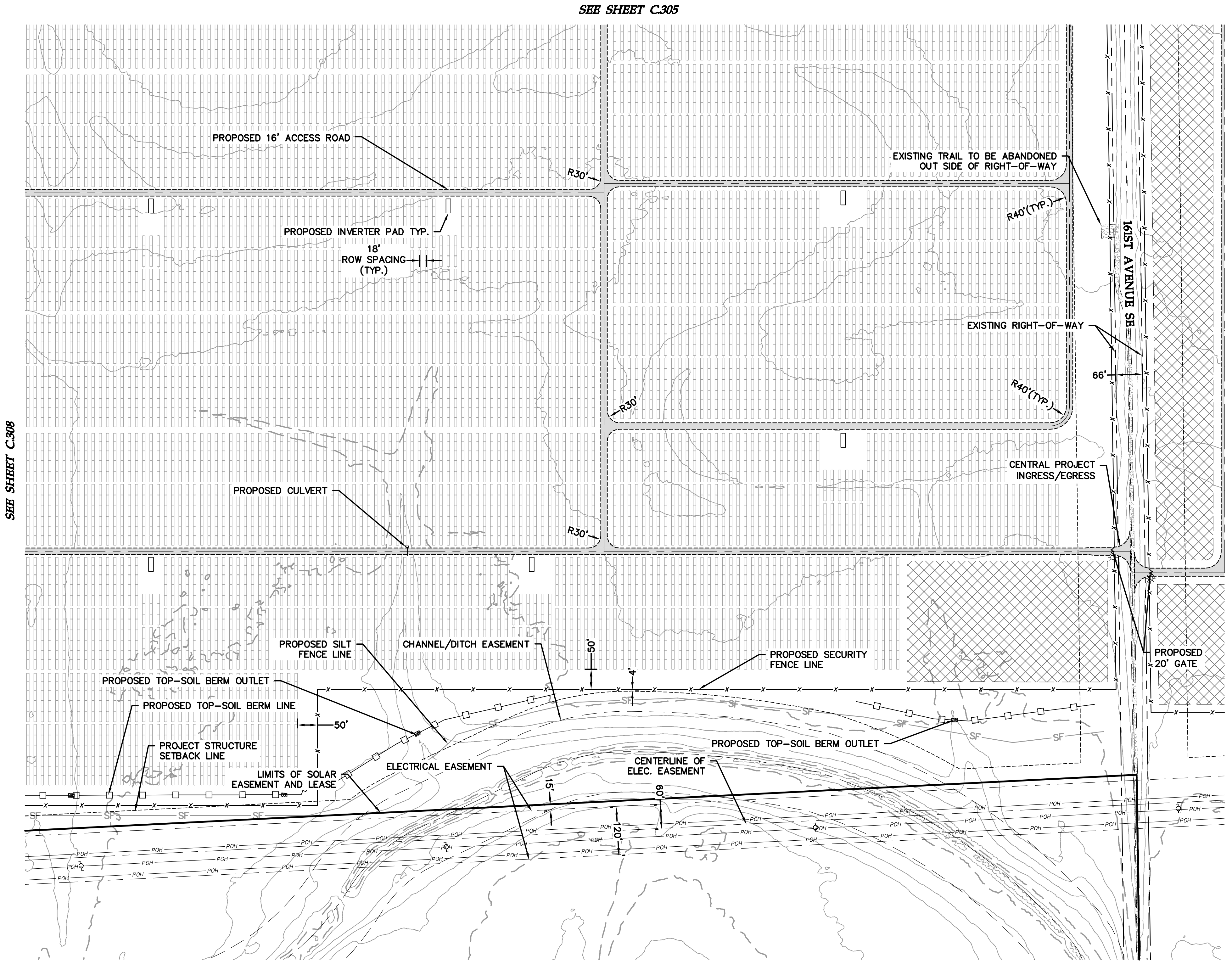

SEE SHEET C.308

SEE SHEET C.305

SEE SHEET C.310

KEY MAP

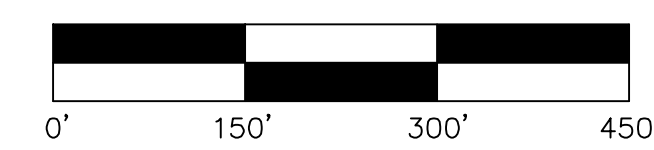
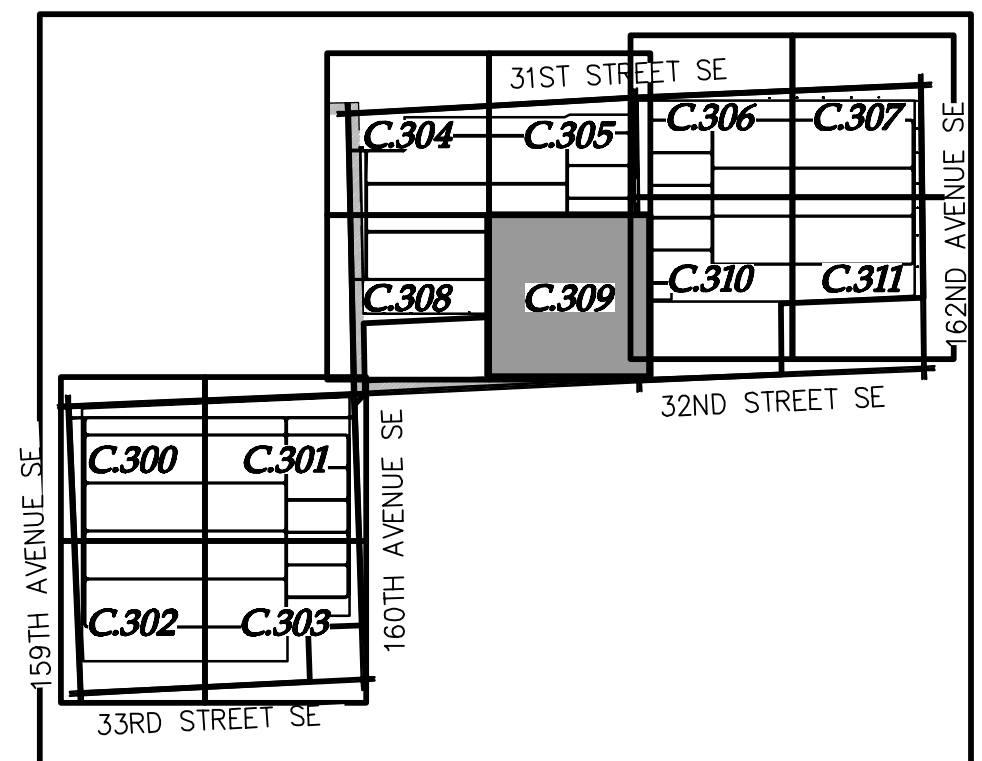

Harmony Solar ND, LLC
 Cass County, ND

Site Plan - 10

Issued for Permit
 Not For Construction

Date: **06/25/18**
 Drawing No: **C.309**

LEGEND & ABBREVIATIONS

	EX. PROJECT BOUNDARY LINE
	EX. SECTION LINE
	EX. EASEMENT LINE
	EX. RIGHT-OF-WAY LINE
	EX. OVERHEAD POWERLINE
	EX. INDEX CONTOUR LINE
	EX. INTERVAL CONTOUR LINE
	EX. WETLAND
	EX. PAVED ROAD
	EX. GRAVEL ROAD
	EX. TRAVEL PATH
	PROPOSED SECURITY FENCE LINE
	PROPOSED SETBACK LINE
	PROPOSED SILT FENCE LINE
	PROPOSED OVERHEAD LINE
	PROPOSED ACCESS ROAD
	PROPOSED SOLAR ARRAY
	PROPOSED LAYDOWN AREA
	PROPOSED TOP SOIL BERM LINE
	PROPOSED LAYDOWN AREA
	PROPOSED ENTRANCE LIGHTING
	EXISTING
	SETBACK
	FUTURE TRANSMISSION LINE EASEMENT

GENERAL NOTES:

1. THE PROPOSED PROJECT IS NOT ANTICIPATED TO HAVE MAJOR GRADING ACTIVITIES FOR THE CONSTRUCTION OF THE PROJECT.
2. MINOR SURFACE SMOOTHING MAY OCCUR FOR SOLAR PANEL INSTALLATION.
3. CONTRACTOR SHALL INSTALL ALL PERIMETER EROSION AND SEDIMENT CONTROL DEVICES PRIOR TO UPSLOPE DISTURBANCE ACTIVITIES.
4. SITE PREPARATION INCLUDES BUT IS NOT LIMITED TO CLEARING/GRUBBING, MINOR GRADING, COMPACTION, MOWING OF VEGETATION, AND RESTABILIZATION OF DISTURBED AREA.
5. ACCESS ROADS WILL BE CONSTRUCTED TO MATCH THE SURROUNDING EXISTING GROUND ELEVATIONS TO ALLOW THE CONTINUATION OF DRAINAGE PATTERNS.
6. OVERALL DRAINAGE PATTERNS WILL NOT BE ALTERED WITH SOLAR DEVELOPMENT.
7. A TEMPORARY STORAGE POND WILL BE REQUIRED DURING THE DURATION OF CONSTRUCTION IN ACCORDANCE TO PROJECT SWPPP REQUIREMENTS.

Designed: BCV
Checked: ADC
Drawn: BCV

Record Drawing by/date:

Revisions:

#	DATE	DESCRIPTION

Prepared for:

GERONIMO ENERGY
 Geronimo Energy,
 7650 Edinborough Way, Suite 725
 Edina, MN 55435

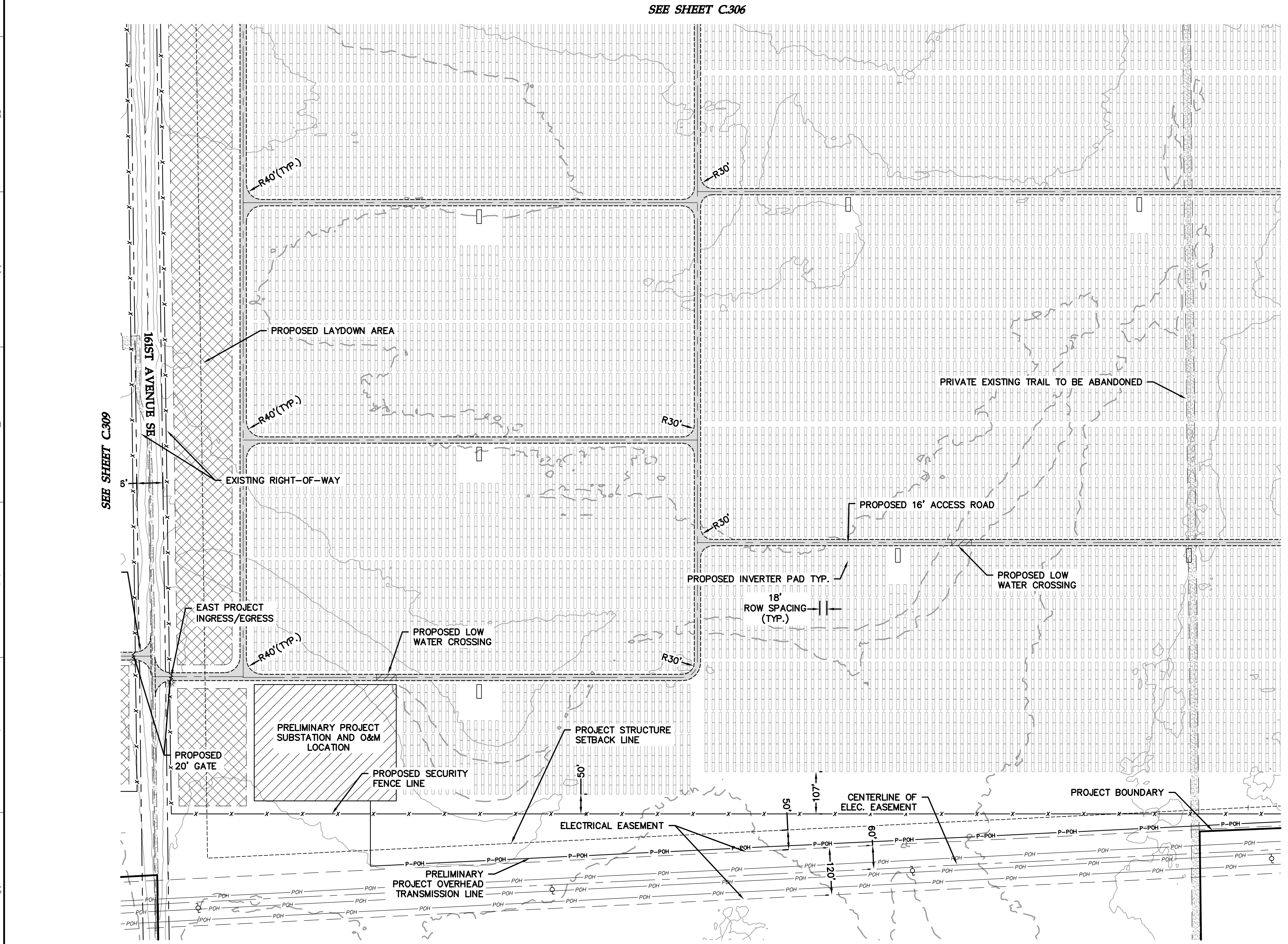

KEY MAP

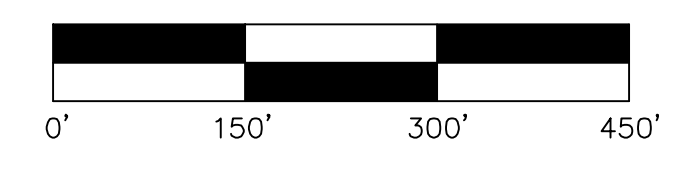
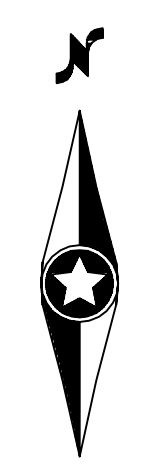
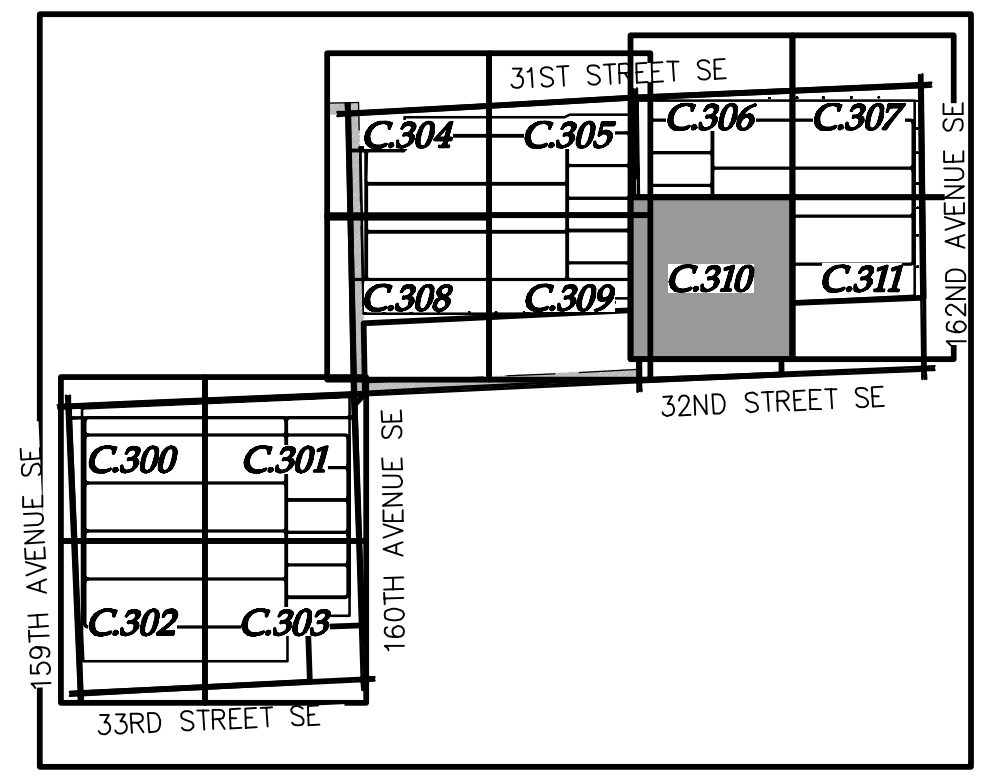

Harmony Solar ND, LLC
 Cass County, ND

Site Plan - 11

Issued for Permit
 Not For Construction

Date: 06/25/18
 Drawing No: C.310

LEGEND & ABBREVIATIONS

	EX. PROJECT BOUNDARY LINE
	EX. SECTION LINE
	EX. EASEMENT LINE
	EX. RIGHT-OF-WAY LINE
	EX. OVERHEAD POWERLINE
	EX. INDEX CONTOUR LINE
	EX. INTERVAL CONTOUR LINE
	EX. WETLAND
	EX. PAVED ROAD
	EX. GRAVEL ROAD
	EX. TRAVEL PATH
	PROPOSED SECURITY FENCE LINE
	PROPOSED SETBACK LINE
	PROPOSED SILT FENCE LINE
	PROPOSED OVERHEAD LINE
	PROPOSED ACCESS ROAD
	PROPOSED LAYDOWN AREA
	PROPOSED TOP SOIL BERM LINE
	PROPOSED ENTRANCE LIGHTING
	EXISTING
	SETBACK
	FUTURE TRANSMISSION LINE EASEMENT

GENERAL NOTES:

1. THE PROPOSED PROJECT IS NOT ANTICIPATED TO HAVE MAJOR GRADING ACTIVITIES FOR THE CONSTRUCTION OF THE PROJECT.
2. MINOR SURFACE SMOOTHING MAY OCCUR FOR SOLAR PANEL INSTALLATION.
3. CONTRACTOR SHALL INSTALL ALL PERIMETER EROSION AND SEDIMENT CONTROL DEVICES PRIOR TO UPSLOPE DISTURBANCE ACTIVITIES.
4. SITE PREPARATION INCLUDES BUT IS NOT LIMITED TO CLEARING/GRUBBING, MINOR GRADING, COMPACTION, MOWING OF VEGETATION, AND RESTABILIZATION OF DISTURBED AREA.
5. ACCESS ROADS WILL BE CONSTRUCTED TO MATCH THE SURROUNDING EXISTING GROUND ELEVATIONS TO ALLOW THE CONTINUATION OF DRAINAGE PATTERNS.
6. OVERALL DRAINAGE PATTERNS WILL NOT BE ALTERED WITH SOLAR DEVELOPMENT.
7. A TEMPORARY STORAGE POND WILL BE REQUIRED DURING THE DURATION OF CONSTRUCTION IN ACCORDANCE TO PROJECT SWPPP REQUIREMENTS.

KEY MAP

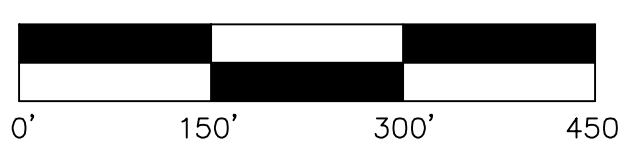
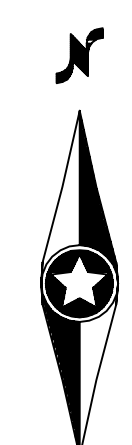
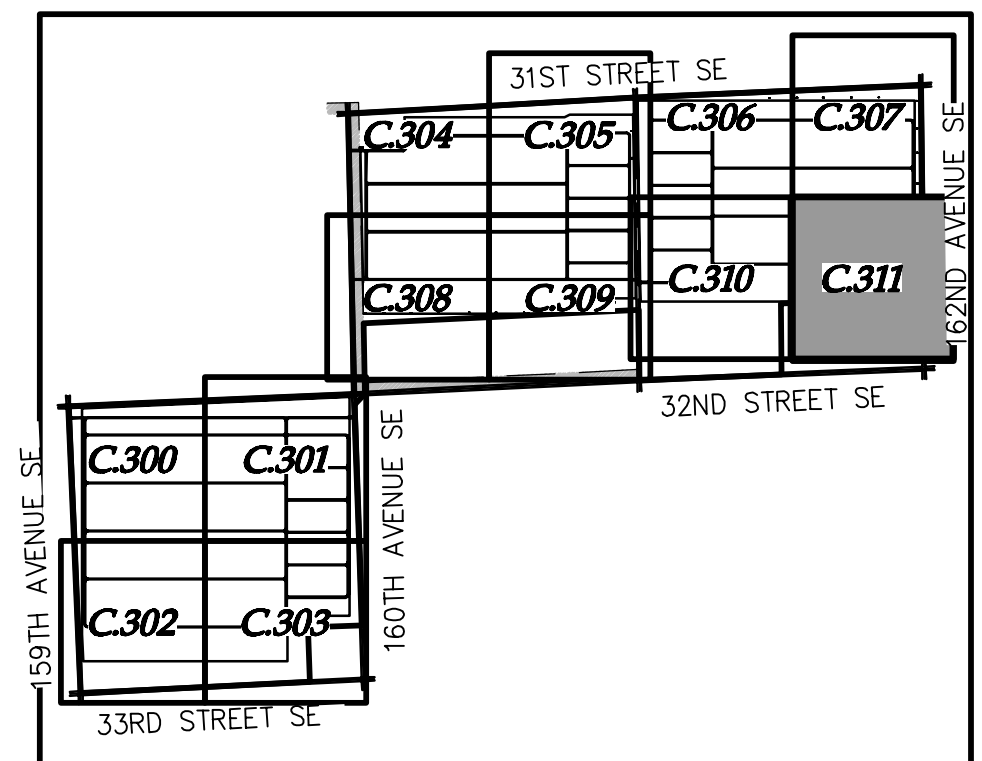

Westwood

Phone (952) 937-5150 12701 Whitewater Drive, Suite #300
 Fax (952) 937-5822 Minneapolis, MN 55443
 Toll Free (888) 937-5150 westwoods.com
 Westwood Professional Services, Inc.

Designed: BCV
 Checked: ADC
 Drawn: BCV

Record Drawing by/date:

Revisions #	DATE	DESCRIPTION

Prepared for:



Geronimo Energy,
 7650 Edinborough Way, Suite 725
 Edina, MN 55435

**Harmony Solar
 ND, LLC**

Cass County, ND

Site Plan - 12

Issued for Permit
 Not For Construction

Date: **06/25/18**
 Drawing No: **C.311**

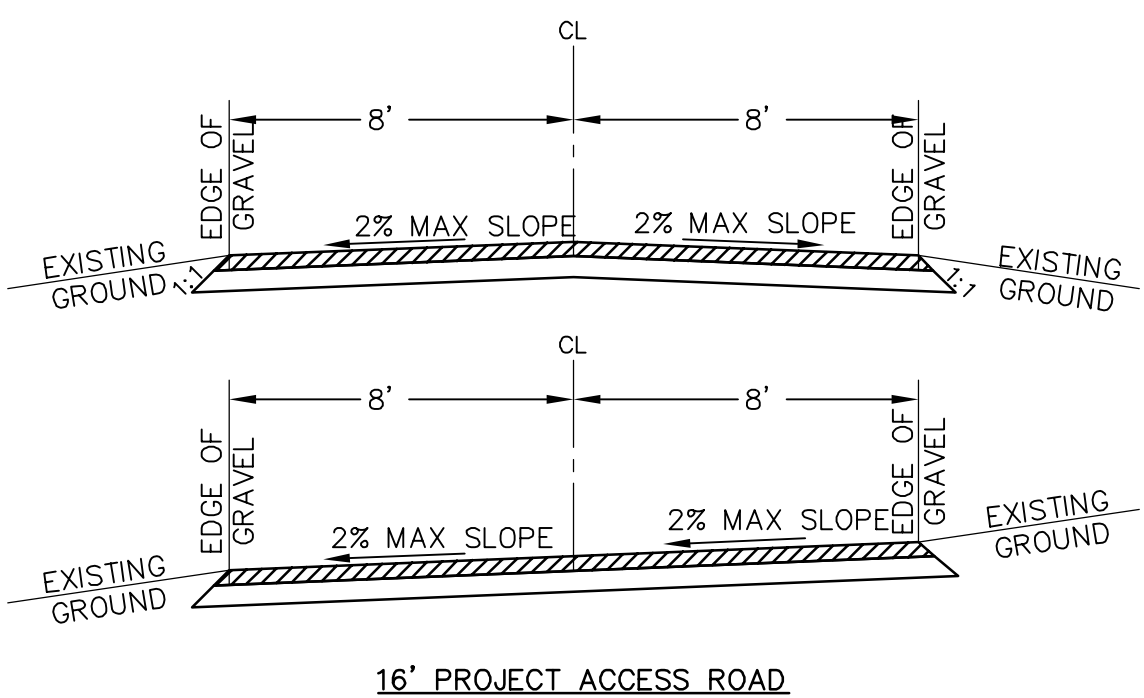

16' PROJECT ACCESS ROAD

NOTES:

1. CONTRACTOR SHALL CONSTRUCT CROSS-SLOPE ROAD SECTION WHERE ACCESS ROADS ARE CONSTRUCTED ON A SIDE SLOPE, AND WHERE OTHERWISE NOTED ON PLANS, TO ENSURE THAT ROADS AND SHOULDERS REMAIN WELL DRAINED AT ALL TIMES.
2. CONTRACTOR SHALL MAINTAIN POSITIVE DRAINAGE ACROSS ACCESS ROADS

Westwood	TYPICAL SOLAR ACCESS ROAD	LAST REVISED: 04/20/17
		RD01

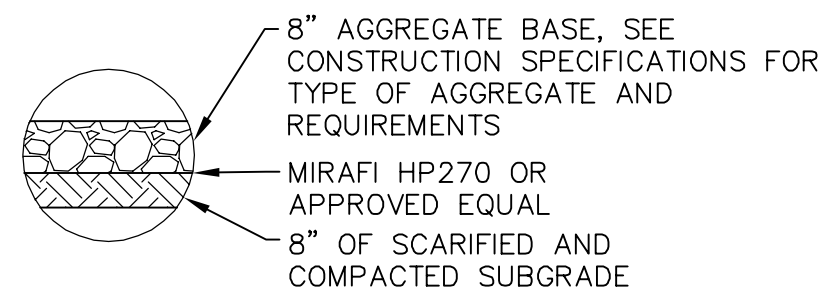

16' ACCESS ROAD CROSS SECTION

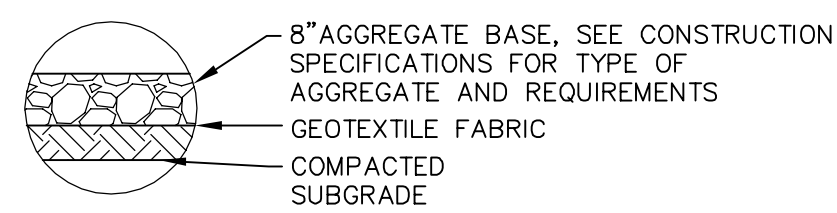

TEMPORARY LAYDOWN AREA

NOTE:

1. STRUCTURAL SECTIONS SHOWN ARE THE MINIMUM THICKNESS REQUIREMENTS DURING NORMAL FIELD CONDITIONS. THE SECTIONS MAY NEED TO BE INCREASED BASED ON ACTUAL FIELD CONDITIONS AT THE TIME OF CONSTRUCTION. CONDITIONS INCLUDE BUT ARE NOT LIMITED TO CONSTRUCTION DURING UNUSUALLY WET PERIODS, OR IN LOW/WET AREAS.
2. CEMENT/LIME/FLY ASH STABILIZED ROADS MAY BE USED TO LIMIT AGGREGATE THICKNESS AND/OR TO DEAL WITH SATURATED SUBGRADE CONDITIONS.

Westwood	TYPICAL STRUCTURAL CROSS SECTIONS	LAST REVISED: 05/02/17
		RD02

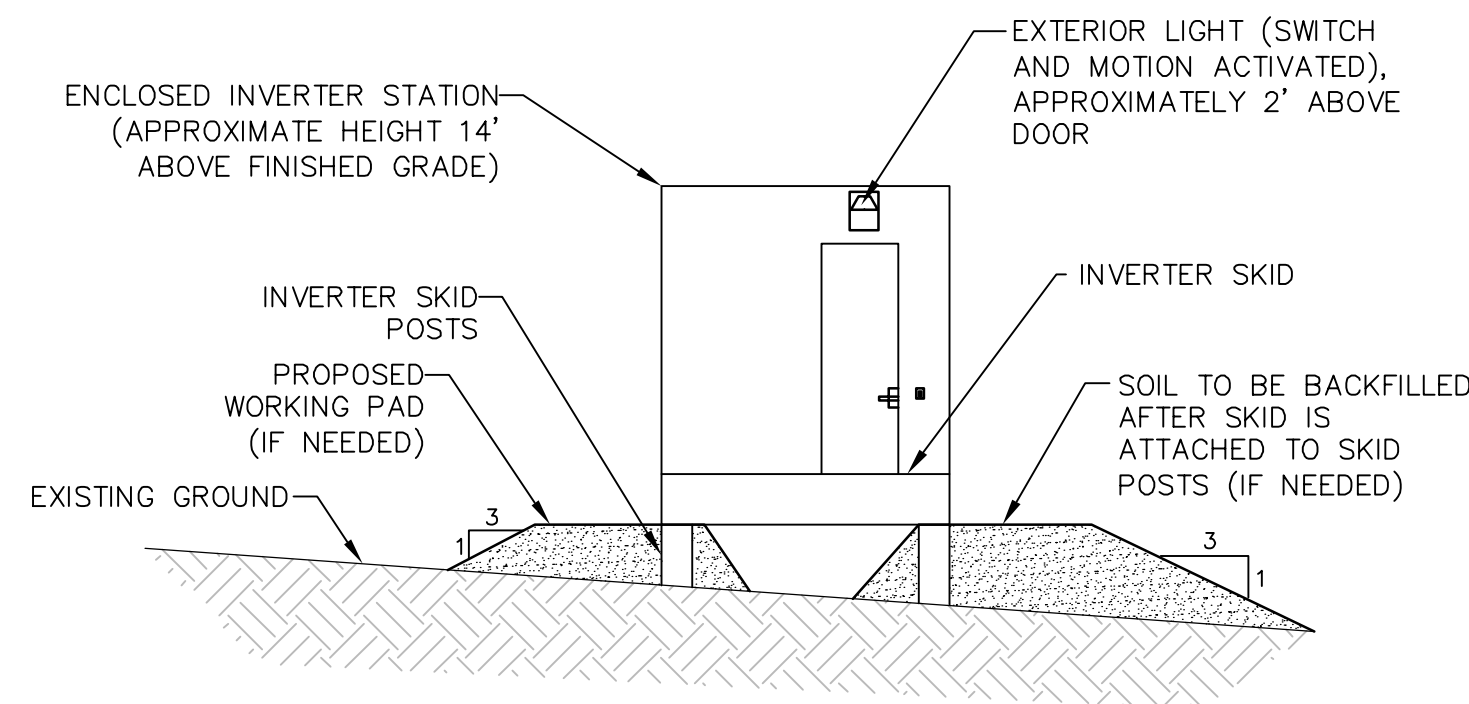

SECTION VIEW

NOTE:

1. SOIL SHALL BE BACKFILLED AROUND INVERTER PAD IF A WORKING SURFACE IS NEEDED FOR ELECTRICAL EQUIPMENT

Westwood	TYPICAL SOLAR INVERTER ON DRIVEN PILES	LAST REVISED: 08/20/15
		INV01

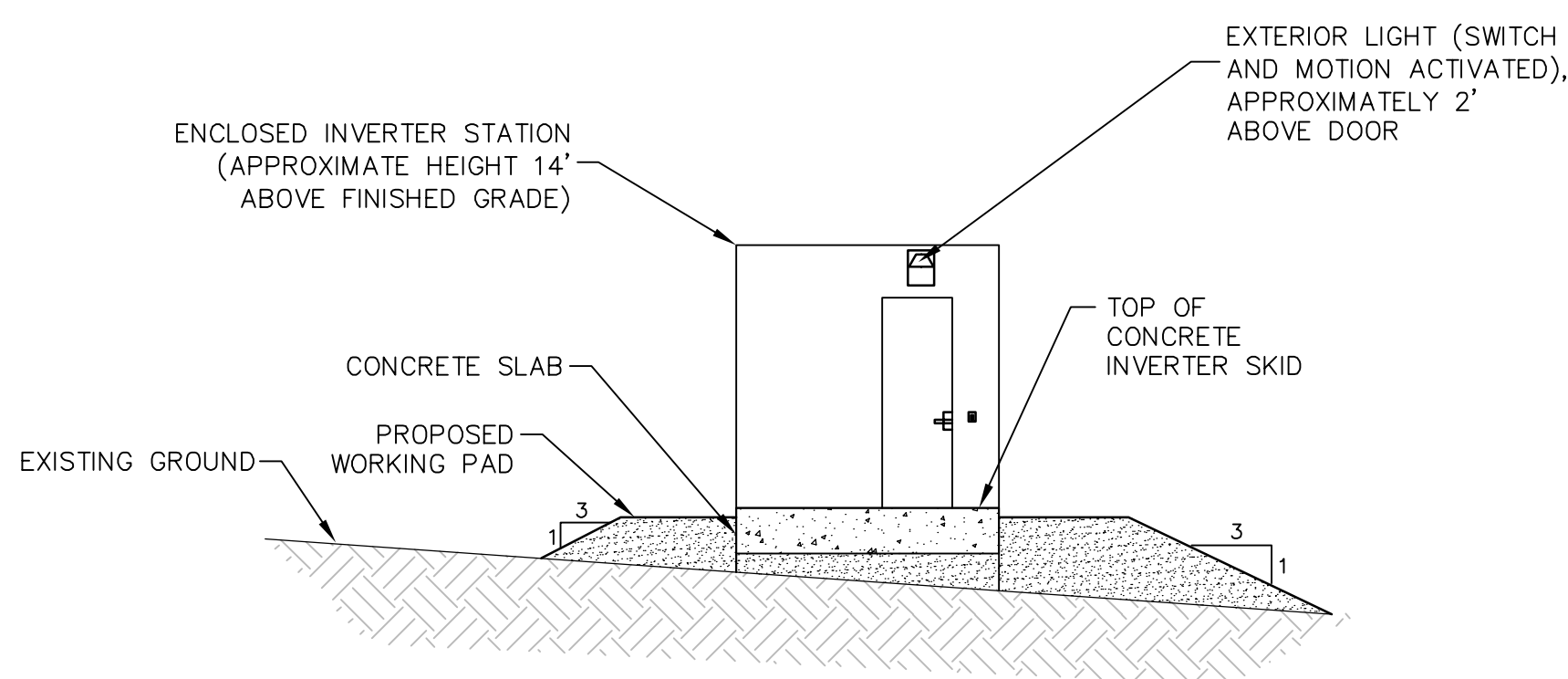

SECTION VIEW

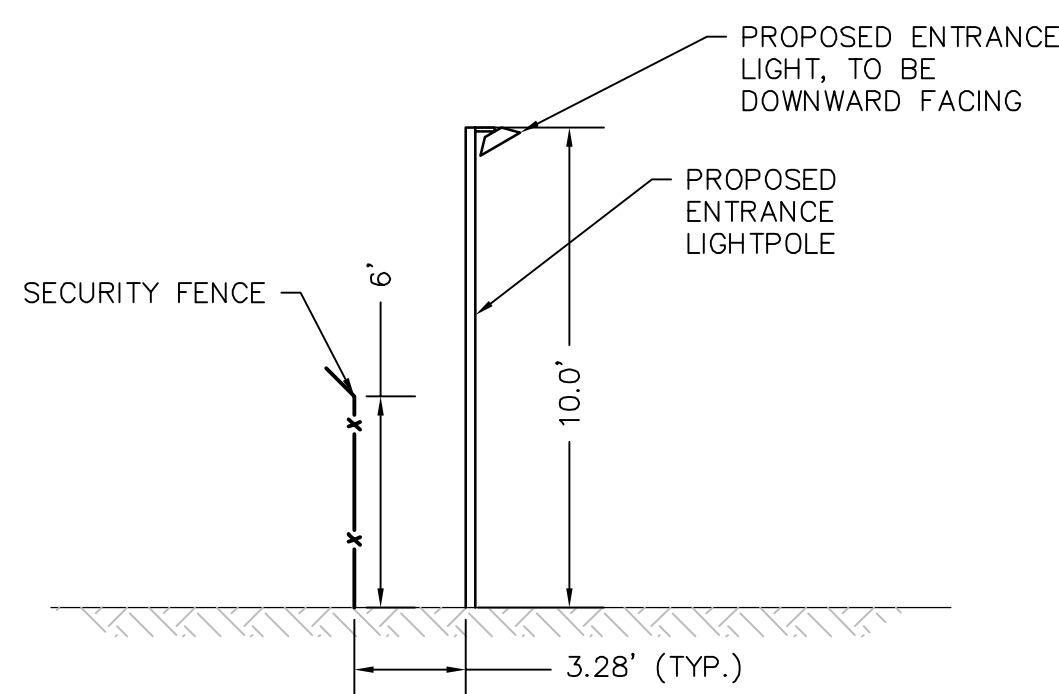

NOTE:

1. TYPICAL HEIGHT OF POLE WILL BE 10.0'
2. BRIGHTNESS OF LIGHT SHALL BE BETWEEN 1500 AND 3000 LUMENS
3. LIGHT ACTIVATION SHALL BE MANUAL AND AUTOMATIC BY THE SECURITY SYSTEM IN CASE OF AN INTRUSION (NON-MOTION ACTIVATED)
4. LIGHT POLE SHALL BE PLACE APPROXIMATELY 3.28' INSIDE OF FENCE

Westwood	TYPICAL ENTRANCE LIGHTING	LAST REVISED: 10/22/15
		LP01

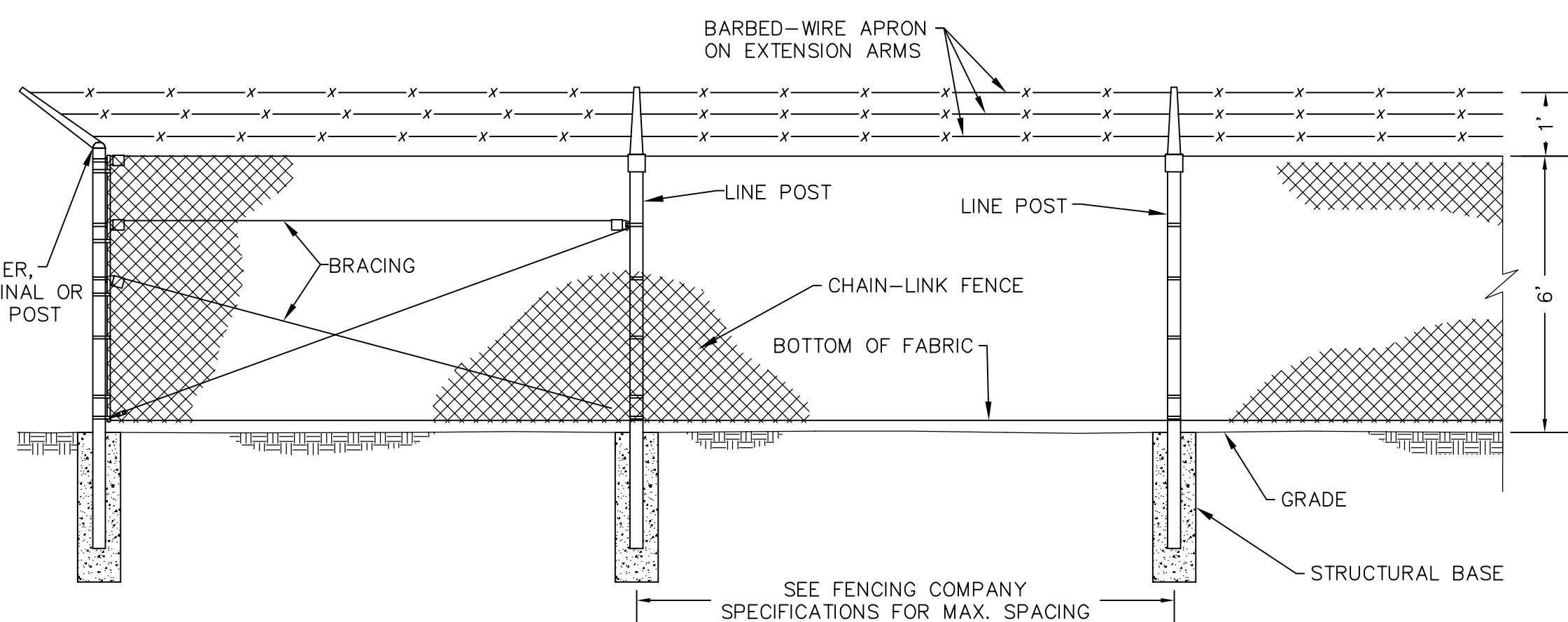

NOTE:

1. FENCE AND GATE TYPE TO BE APPROVED BY OWNER PRIOR TO CONSTRUCTION
2. STRUCTURAL DESIGN TO BE PROVIDED BY FENCE SUPPLIER
3. DIMENSIONS AND INFORMATION SHOWN ABOVE ARE FOR REFERENCE ONLY. ACTUAL DIMENSIONS AND INFORMATION TO BE PROVIDED BY MANUFACTURER/SUPPLIER
4. FENCING TO BE USED SHALL BE BLACK VINYL CHAIN LINK

Westwood	CHAIN-LINK SECURITY FENCE DETAIL	LAST REVISED: 08/04/16
	(NOT TO SCALE)	FN01

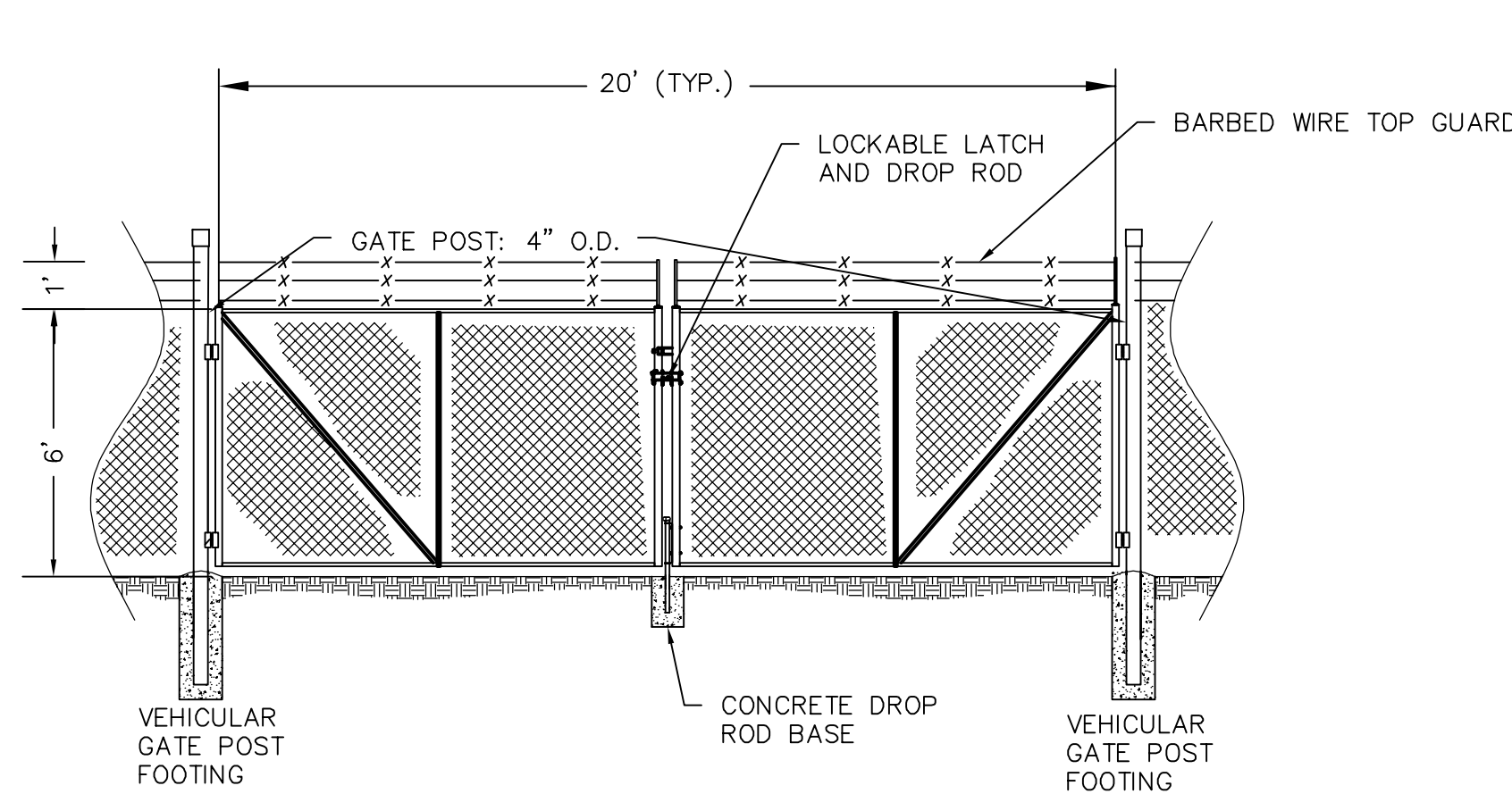

NOTE:

1. FENCE AND GATE TYPE TO BE APPROVED BY OWNER PRIOR TO CONSTRUCTION
2. STRUCTURAL DESIGN TO BE PROVIDED BY FENCE SUPPLIER
3. DIMENSIONS AND INFORMATION SHOWN ABOVE ARE FOR REFERENCE ONLY. ACTUAL DIMENSIONS AND INFORMATION TO BE PROVIDED BY MANUFACTURER/SUPPLIER
4. A KNOX PAD LOCK WILL BE PLACE ON CHAINED GATES OR KNOX BOX WITH GATE ACCESS KEYS WILL BE MOUNTED AT THE MAIN ENTRANCE FOR FIRE DEPARTMENT ACCESS.

Westwood	CHAIN-LINK SECURITY SWING GATE	LAST REVISED: 08/04/16
		FN05

Designed: BCV

Checked: ADC

Drawn: BCV

Record Drawing by/date:

Revisions: # DATE DESCRIPTION

Prepared for:



Geronimo Energy,
 7650 Edinborough Way, Suite 725
 Edina, MN 55435

**Harmony Solar
 ND, LLC**

Cass County, ND

Construction Details

Issued for Permit
 Not For Construction

Date: 06/25/18

Drawing No: C.400

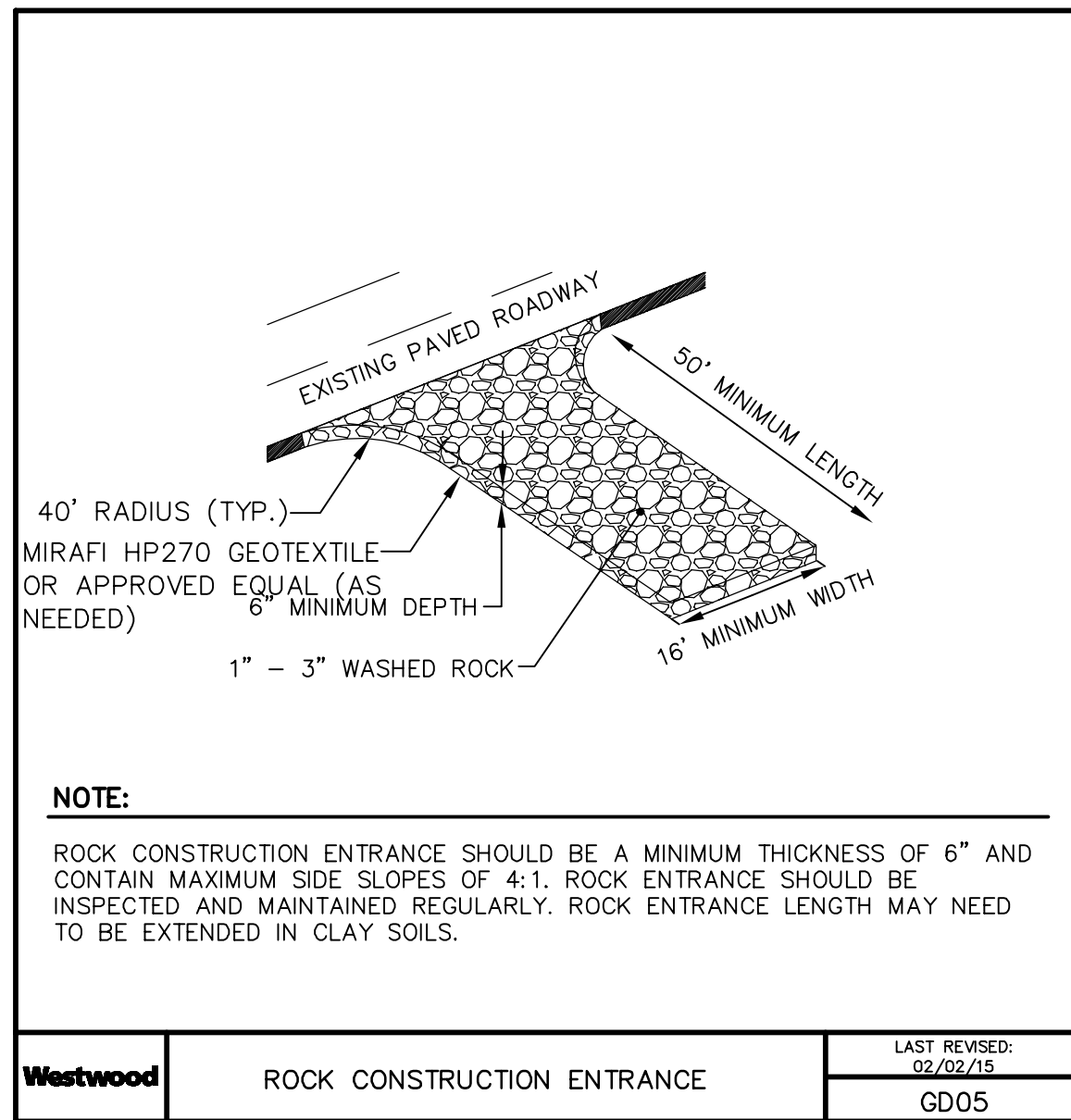

Westwood	ROCK CONSTRUCTION ENTRANCE	LAST REVISED: 02/02/15 GD05
----------	----------------------------	-----------------------------------

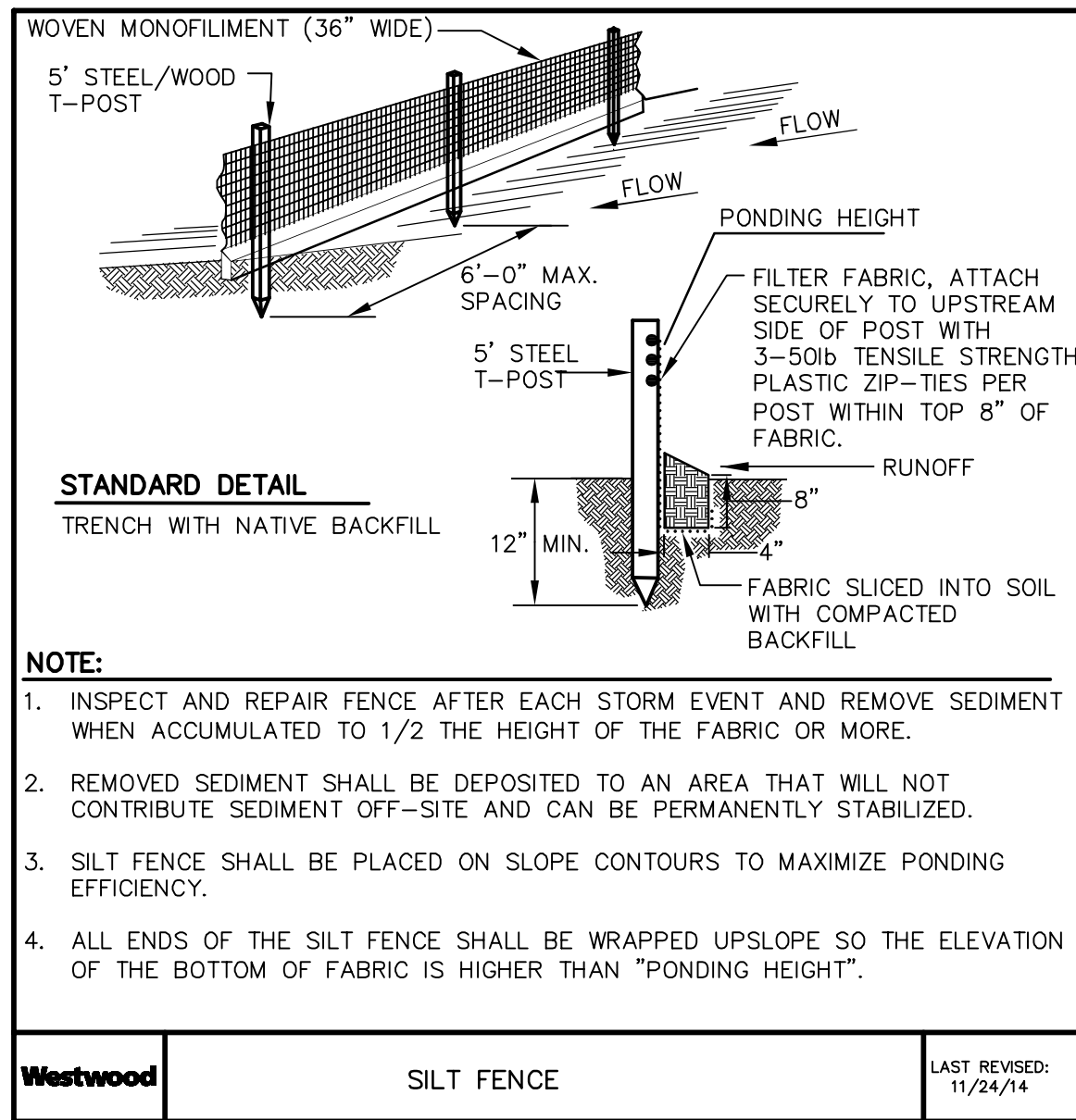

Westwood	SILT FENCE	LAST REVISED: 11/24/14
----------	------------	---------------------------

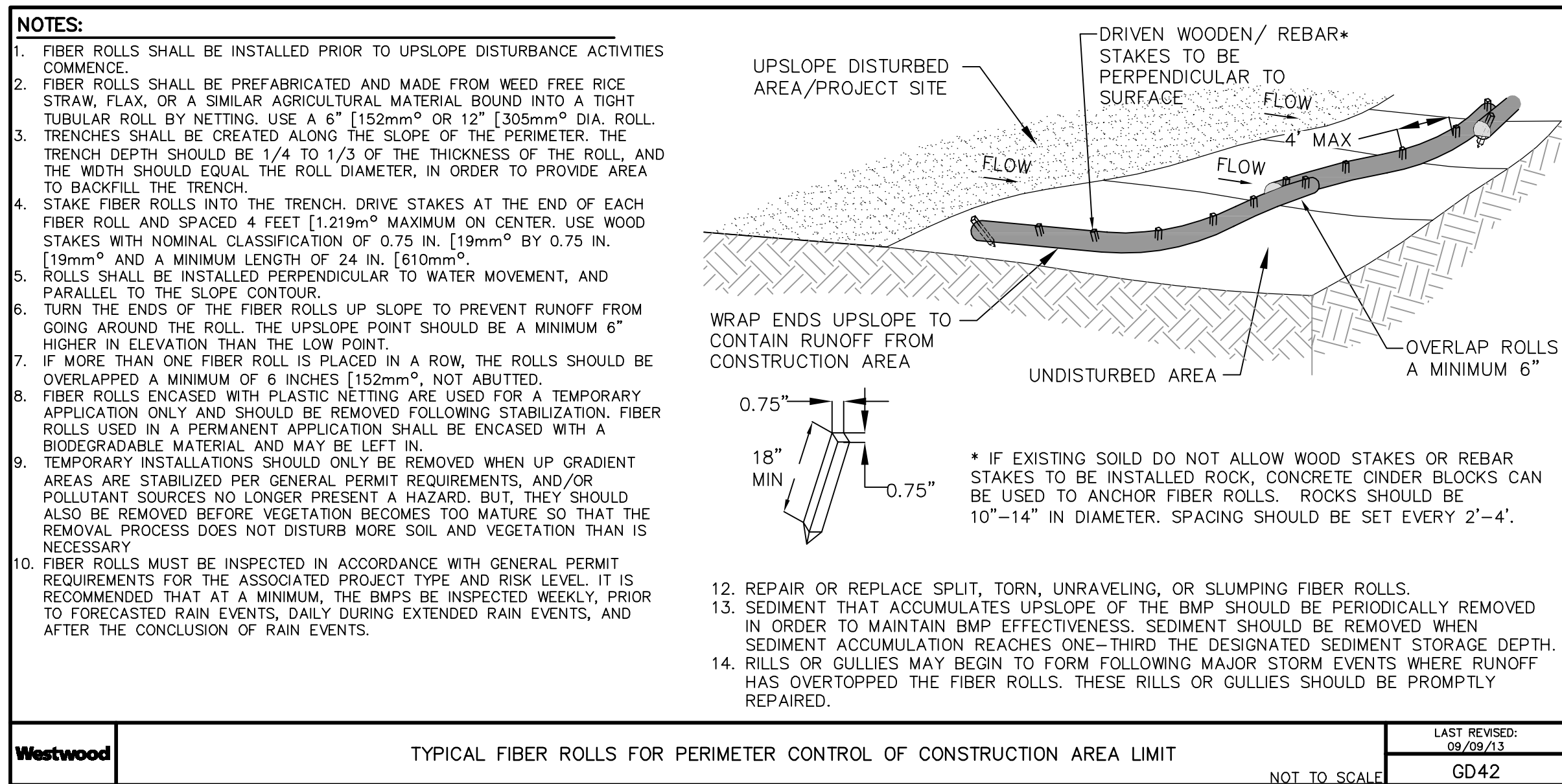

Westwood	TYPICAL FIBER ROLLS FOR PERIMETER CONTROL OF CONSTRUCTION AREA LIMIT	LAST REVISED: 09/09/13 GD42
----------	--	-----------------------------------

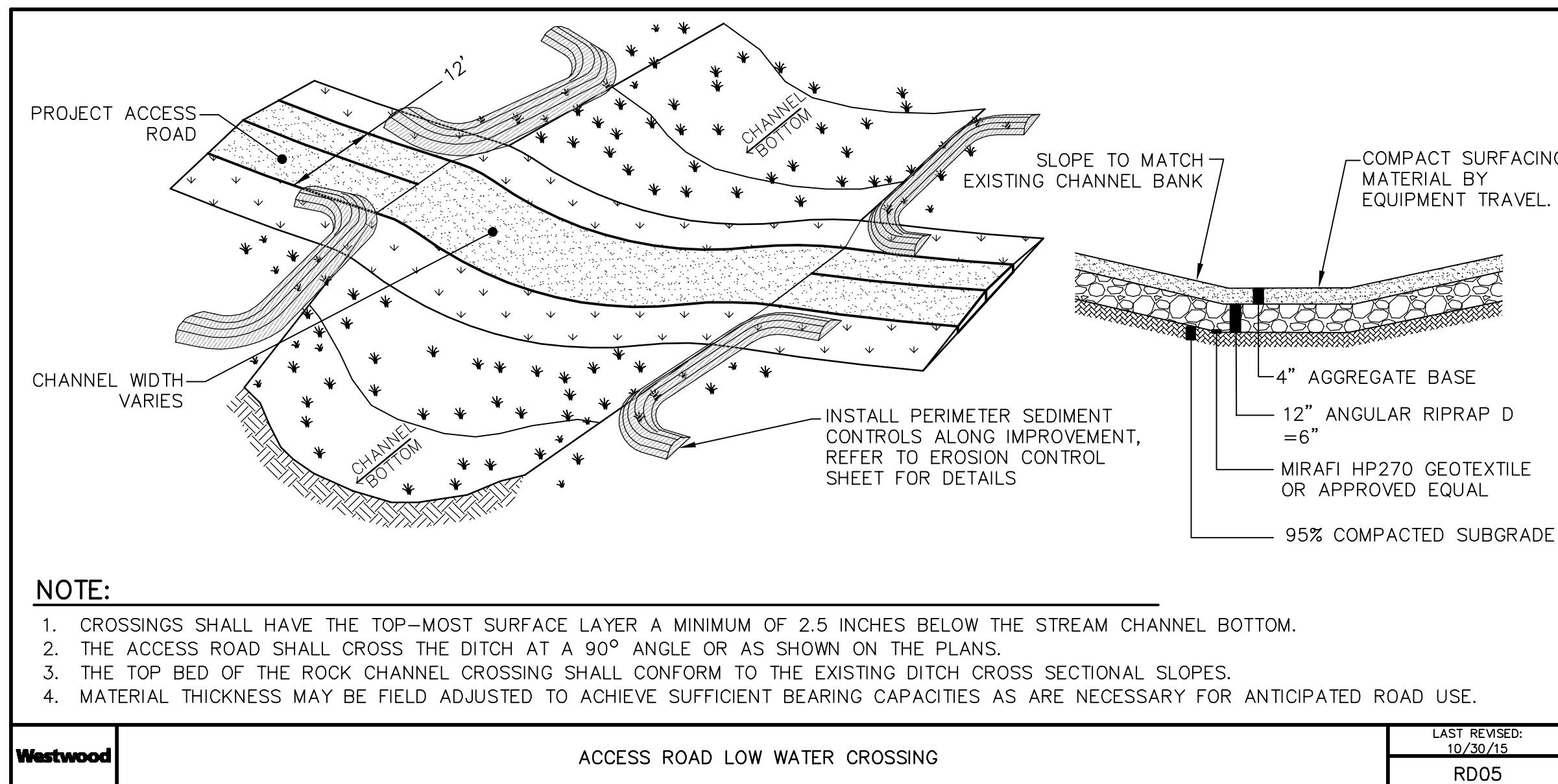

Westwood	ACCESS ROAD LOW WATER CROSSING	LAST REVISED: 10/30/15 RD05
----------	--------------------------------	-----------------------------------

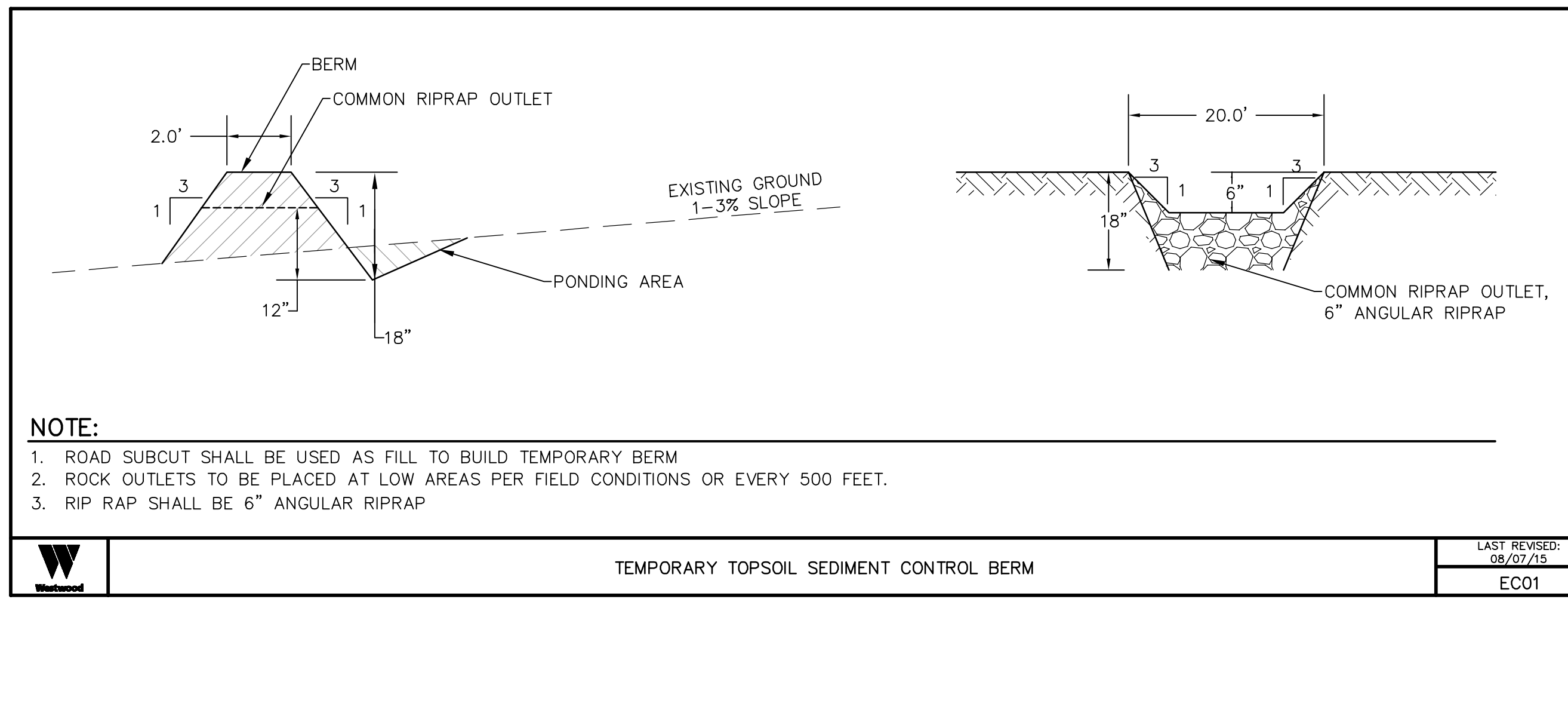

Westwood	TEMPORARY TOPSOIL SEDIMENT CONTROL BERM	LAST REVISED: 08/07/15 EC01
----------	---	-----------------------------------

Westwood

Phone (952) 937-5150 12701 Whitewater Drive, Suite #300
 Fax (952) 937-5822 Minnetonka, MN 55343
 Toll Free (888) 937-5150 westwoods.com
 Westwood Professional Services, Inc.

Designed: BCV
 Checked: ADC
 Drawn: BCV

Record Drawing by/date:

Revisions #	DATE	DESCRIPTION

Prepared for:



Harmony Solar ND, LLC
 Cass County, ND

Construction Details

Issued for Permit
 Not For Construction

Date: 06/25/18
 Drawing No: C.401

Harmony Solar Project
Appendix B
Ten Year Plan

TEN YEAR PLAN: 2018-2028
Harmony Solar ND, LLC

June 2018

In accordance with N.D.C.C. § 49-22-04 and N.D.A.C. Ch. 69-06-02, Harmony Solar ND, LLC (“Harmony Solar”), submits the following Ten Year Plan for years 2018 through 2028.

- (1) *A description of the general location, size, and type of all facilities to be owned or operated by the utility during the ensuing ten years, as well as those facilities to be removed from service during the ten-year period.*

Harmony Solar is proposing to develop and construct an up to 200 MW solar project known as the Harmony Solar Project. Harmony Solar will be located 15 miles west of Fargo in Cass County, ND. The project will consist of solar arrays, inverters, access roads, an electrical collection system, an O&M building and a project step-up substation. The project will be fully enclosed within a safety fence.

Harmony Solar does not currently have any facilities within North Dakota and, therefore, has no plans to decommission any facilities. The Harmony Solar Project will have an estimated life of greater than 10 years. As such, Harmony does not have any plans to decommission any proposed facilities within the timeframe of this plan.

- (2) *An identification of the location of the tentative preferred site for all electric energy conversion facilities and the tentative location of all electric transmission facilities on which construction is intended to be commenced within the ensuing five years and such other information as may be required by the commission. The site and corridor identification shall be made in compliance with the criteria published by the commission pursuant to section 49-22-05.1.*

The Harmony Solar Project will be located west of Fargo, North Dakota approximately 4 miles northeast of Casselton in eastern Cass County. A map of the proposed site for Harmony Solar is provided in Exhibit A, attached hereto. The project will be designed so as to comply with the exclusion and avoidance areas referenced in Section 49-22-05.1 of the North Dakota Century Code and identified in Sections 69-06-08-01 of the North Dakota Administrative Code.

- (3) *A description of the efforts by the utility to coordinate the plan with other utilities so as to provide a coordinated regional plan for meeting the utility needs of the region.*

Throughout the development of the project, Harmony Solar has and will continue to engage and coordinate with the Midcontinent Independent Transmission

System Operator (“MISO”), the local transmission owner, Xcel Energy, and the local electrical cooperatives regarding the Harmony Solar Project.

In June of 2017, Harmony Solar moved its request to MISO for interconnection of 200 MW of solar generation at Xcel Energy’s Bison Substation into the Definitive Planning Phase. Harmony Solar’s Interconnection Application was filed per the MISO Business Practice Manual 015 for Generator Interconnection. Harmony Solar’s Interconnection and MISO’s administration of the application are consistent with MISO’s Open Access Transmission, Energy and Operating Reserves Market Tariff, and per the operating policies of the Midwest Reliability Organization designed to facilitate the administration of efficient energy markets.

- (4) *A description of the efforts to involve environmental protection and land-use planning agencies in the planning process, as well as other efforts to identify and minimize environmental problems at the earliest possible stage in the planning process.*

Harmony Solar has utilized internal environmental personnel, as well as external environmental consultants, to conduct studies and analyses of the Harmony Solar Project to ensure the project will comply with the siting criteria set forth in Chapter 49-22 of the North Dakota Century Code, as well as Section 69-06-08-01 of the North Dakota Administrative Code. Additionally, Harmony Solar has consulted and will continue to consult with applicable state and federal agencies to avoid, minimize, and/or mitigate any impacts to the environment from the construction and operation of the project. Harmony Solar has been and will continue to work with Cass County and Harmony Township to ensure conformance with local land use regulations.

- (5) *A statement of the projected demand for the service rendered by the utility for the ensuing ten years and the underlying assumptions for the projection, with that information being as geographically specific as possible, and a description of the manner and extent to which the utility will meet the projected demands.*

Harmony Solar is proposing to construct this facility to sell energy, capacity and renewable energy credits (“RECs”), either bundled or unbundled, to one or more electric utilities and/or commercial customers. Harmony is actively marketing the project to a number of potential off-takers and may sell the power in the form of a power purchase agreement (“PPA”), or the Project could be owned directly by a utility.

As an independent power producer, Harmony Solar is not limited to the needs of one region and is able to bid into multiple wholesale markets across the region. For example, over the past year Harmony Solar was eligible to bid into 8 utility and 14 corporate/industrial power supply proposal requests in the region. Utilities and other customers seeking to diversify and build their energy generation

portfolios are attracted to solar energy projects because of long-term, fixed, competitive pricing, high capacity value, environmental benefits and existing and potential renewable energy policies.

Renewable Energy Policies

In March 2007, North Dakota enacted legislation (H.B. 1506) establishing an *objective* that 10% of all retail electricity sold in the state be obtained from renewable energy and recycled energy by 2015. The objective must be measured by qualifying megawatt-hours (“MWh”) delivered at retail, or by credits purchased and retired to offset non-qualifying retail sales. This objective is voluntary; there is no penalty or sanction for a retail provider of electricity that fails to meet the objective. Municipal utilities and electric cooperatives that receive wholesale electricity through a municipal power agency or generation and transmission cooperative may aggregate their renewable and recycled energy objective resources to meet the objective.

As of reports filed with the Commission in 2017, all filing utilities indicated that they presently meet their 10% objective for renewables. However, North Dakota is proximate to other jurisdictions that also have renewable policies. Minnesota, in particular, has a standard that requires Xcel Energy to obtain 30% of its energy from renewables by 2020, and all other utilities to obtain 25% of their energy from renewables by 2025. In addition, Minnesota investor-owned utilities are required to obtain 1.5% of their energy from solar by 2020. North Dakota’s available land and good insolation, along with newly constructed transmission lines, create an ideal environment for solar energy projects to meet Minnesota’s renewable and solar standard.

Economic Energy and Capacity

With improving technology and falling costs, utilities are beginning to include solar projects in their resource plans as long-term economic energy and capacity resources. In North Dakota, peak solar generation has a high correlation with the MISO’s coincident peak, which determines the reserve margins MISO utilities must maintain for reliability and reserve sharing purposes. Recent solar pricing has shown that the costs of energy and capacity of utility scale solar are on par with building a simple cycle CT to provide peaking power. (Lazard’s Levelized Cost of Energy Analysis 10.0, 2016).





For example, in its 2015 Resource Plan filing, the Commission approved Xcel Energy’s proposed purchase of up to 1000 MW of solar by 2021, even though it has already exceeded Minnesota’s solar energy standard.

Commercial and Industrial Demand

In addition to traditional utility demand for solar energy, a growing number of corporations are turning to renewable energy to save money on energy and meet sustainability goals. Corporate customers either purchase renewable energy directly or obtain renewable benefits and cost savings through financially settled contracts, sometimes called virtual PPAs. In addition, many utilities are creating “green tariffs,” which allow customers to purchase up to 100% renewable energy from the utility. Corporations such as Apple, Google and Facebook, along with many others, have recently set goals to obtain 100% of their energy from renewables. In 2016, approximately 1600 MW of renewable energy was purchased by commercial and industrial customers, and the number of requests for proposals doubled in 2017 (Renewable Choice Energy, 2017). In a recent survey, 84% of corporations stated that they planned to purchase renewable energy in the next 2 years.

EXHIBIT A

Harmony Solar Cass County, SD Project & Study Area

-  Harmony Solar Study Area (3mi)
-  Harmony Solar Project Area
-  Township/Range
-  Sections

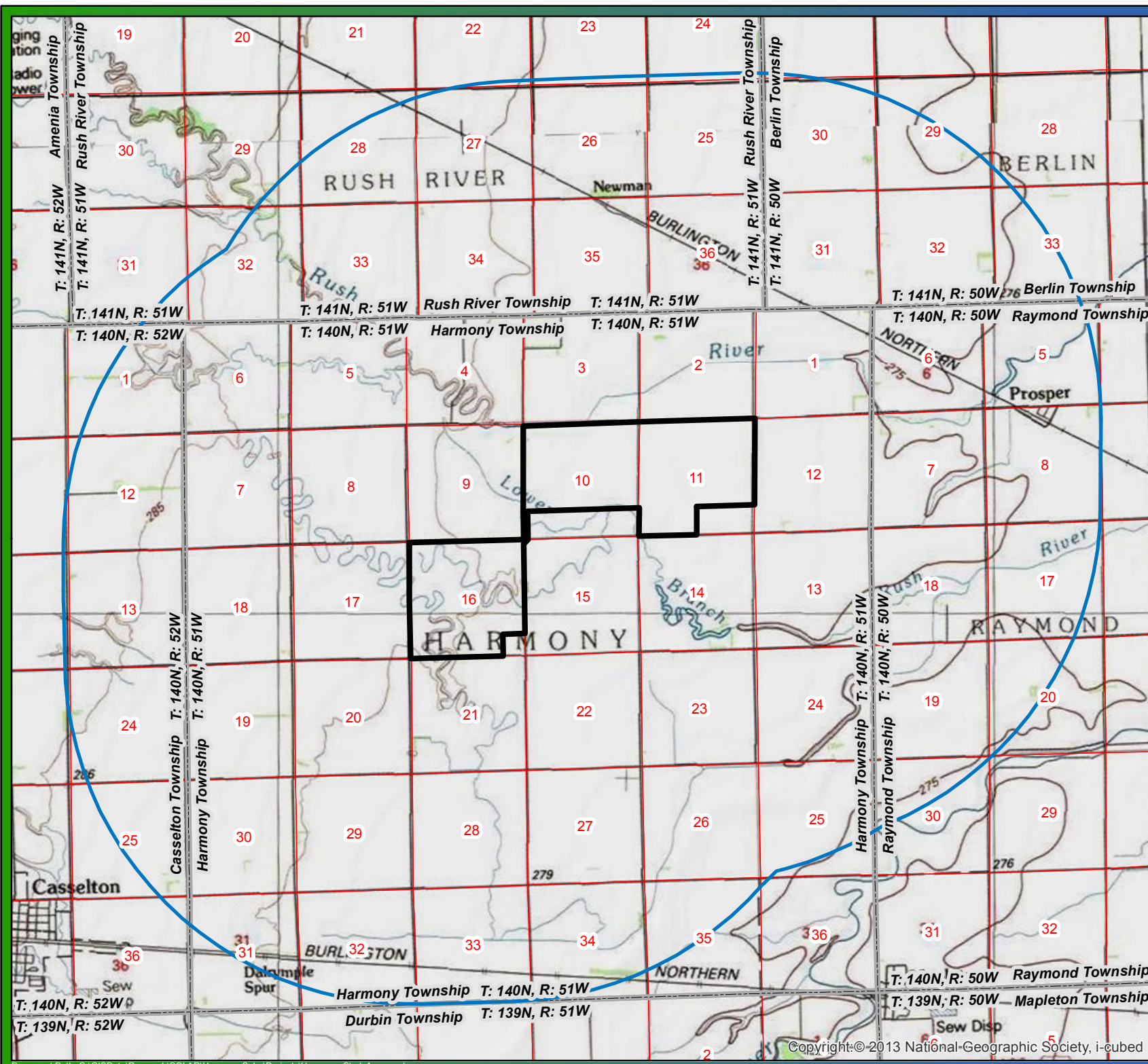
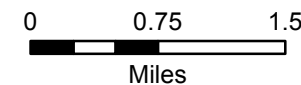

Harmony Solar Project
Appendix C
Agency Outreach and Coordination

Example Project Notification Letter



September 25, 2017

Bonnie Malo
Division of Community Services
1600 E. Century Avenue, PO Box 2057
Bismarck, ND 58503

RE: Requesting Comments on Harmony Solar in Cass County, North Dakota

Dear Bonnie Malo,

Harmony Solar ND, LLC (“Harmony”), a wholly owned subsidiary of Geronimo Energy, LLC, is gathering information and requesting agency comments for a proposed utility scale solar energy project in Cass County, North Dakota.

Harmony will be submitting an Application for a Certificate of Corridor Compatibility to the North Dakota Public Service Commission (“PSC”).

The planned output for the Project is up to 200 megawatts of nameplate solar energy capacity. The Project’s permanent facilities will include:

- Solar modules, inverters and racking;
- Fencing;
- Access roads as required;
- Operations and maintenance (O&M) building;
- Substation facility;
- On-site underground electrical collection lines; and
- Up to two weather stations (up to 20 feet tall).

Harmony will interconnect to the Bison substation located in Section 11 of Township 140, Range 51 via a 345 kV transmission line. The transmission line route has not yet been determined, however it will be under one mile in length and therefore will not be reviewed by the PSC.

The racking layout, access roads and electrical connections have not been finalized at this time. Table 1 provides the sections of land Harmony is evaluating for siting the solar energy project.

Table 1: Sections within the Harmony Project Boundary

State	County	Civil Township Name	Township	Range	Sections
ND	Cass	Harmony	140 N	51 W	10, 11, 16



To facilitate your review, we have enclosed a map of Harmony's location and the associated project boundary.

Harmony will seek a Certificate of Site Compatibility from the North Dakota Public Service Commission (PSC) pursuant to Chapter 49-22 of the North Dakota Century Code and Article 69-06 of the North Dakota Administrative Code. Construction is anticipated to begin as early as spring of 2019 with intended completion by the end of 2020.

The purpose of this letter is to inform your organization of the proposed Project, seek your input regarding any permits and approvals that may be required, and identify interests your organization may have in the Project site or associated study area. Any written agency comments provided in response to this letter will be incorporated into the PSC's review process.

If you require further information or have questions regarding this matter, please contact me at 952-988-9000 or at melissa@geronimoenergy.com.

Sincerely,

Melissa Schmit
Senior Permitting Specialist

Enclosure:
Harmony Location Map

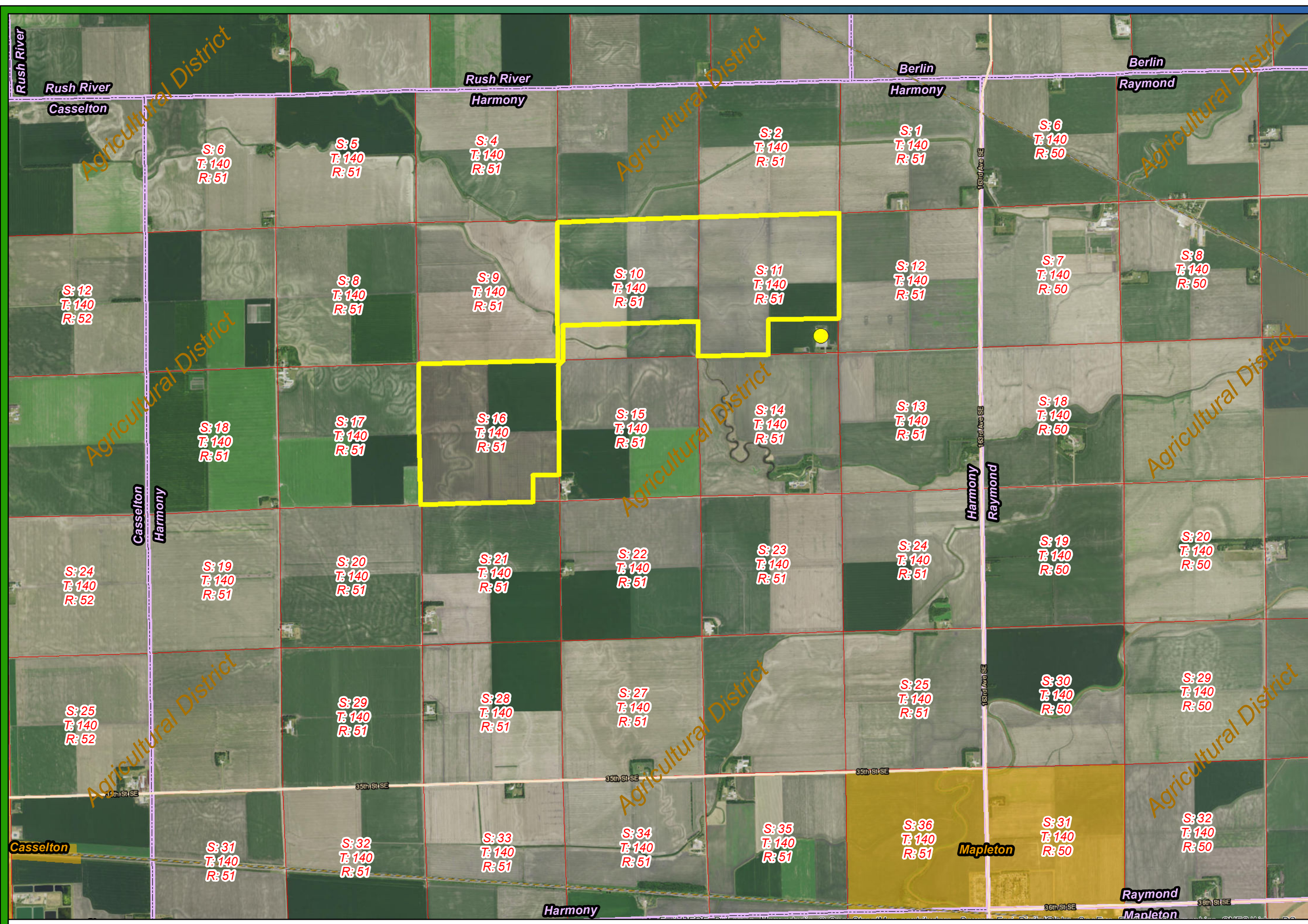

Harmony Solar

- Bison Substation
- Harmony Solar Project Area
- Townships
- Sections
- Municipality

46.941875, -97.105109

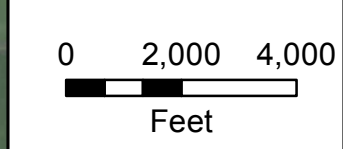
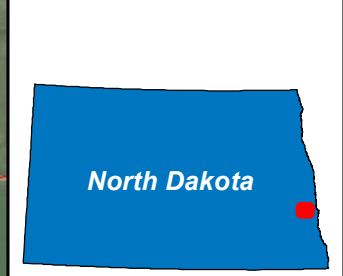

Agency Contact Information

**Harmony Solar Project
Agency Contact Information**

NAME	TITLE	AGENCY	ADDRESS LINE 1	ADDRESS LINE 2	CITY	STATE	ZIP CODE
Bonnie Malo	Director	Division of Community Services		1600 E. Century Avenue, PO Box 2057	Bismarck	ND	58503
Michelle Kommer	Interim Executive Director	Job Service of North Dakota		PO Box 5507	Bismarck	ND	58506
To Whom It May Concern		Minot Airforce Base	5OSS/Airspace	475 Summit Dr.	Minot	ND	58705
Wayne Stenehjem	Attorney General	North Dakota Attorney General		600 E. Boulevard Ave Dept 125	Bismarck	ND	58505
Doug Goehring	Agriculture Commissioner	North Dakota Department of Agriculture		600 E. Boulevard Ave Dept 602	Bismarck	ND	58505
Wayne Kutzer	Director and Executive Officer	North Dakota Department of Career and Technical Education		600 E. Boulevard Ave Dept 270	Bismarck	ND	58505
Jay Schuler	Commissioner	North Dakota Department of Commerce		1600 E. Century Ave., Suite 2	Bismarck	ND	58503
Mylynn Tufte	State Health Office	North Dakota State Department of Health		600 E. Boulevard Ave	Bismarck	ND	58505
Christopher Jones	Executive Director	North Dakota Department of Human Services		600 E. Boulevard Ave Dept 325	Bismarck	ND	58505
Michelle Kommer	Commissioner	North Dakota Department of Labor		600 E. Boulevard Ave Dept 406	Bismarck	ND	58505
John Schneider	Director	North Dakota Economic Development and Finance Division		PO Box 2057	Bismarck	ND	58502
Mike Humann	Directory/ Rangeland Professional	North Dakota Energy Development Impact Office		1707 North 9th Street, PO Box 5523	Bismarck	ND	58506
Lynn Helms	Director	North Dakota Geological Survey		1016 E. Calgary Ave.	Bismarck	ND	58503
Doug Burgum	Governor	North Dakota Governor's Office		600 E. Boulevard Ave	Bismarck	ND	58505
Tom Sorel	Director	North Dakota Highway Department		608 East Boulevard Avenue	Bismarck	ND	58505
Scott Davis	Executive Director	North Dakota Indian Affairs Commission		600 E. Boulevard Ave, Office 117	Bismarck	ND	58505
Rick Hutchens	District Supervisor	North Dakota Industrial Commission		926 East Industrial Drive	Dickinson	ND	58601
Michael Haupt	Land Management Professional	North Dakota Land Department		1707 North 9th Street, PO Box 5523	Bismarck	ND	58506
Melissa Baker		North Dakota Parks and Recreation Department		1600 E. Century Avenue, Suite 3	Bismarck	ND	58503
Justin Kringstad		North Dakota Pipeline Authority		600 E. Boulevard Ave	Bismarck	ND	58505
Jim Gray	SW District Director	North Dakota Soil Conservation Committee	NDSU Extension Service	2718 Gateway Ave., Suite 104	Bismarck	ND	58503
Garland Erbele	State Engineer	North Dakota State Water Commission		900 E. Boulevard Ave #770	Bismarck	ND	58505
Tyler Hamman	Director	North Dakota Transmission Authority		600 E. Boulevard Ave	Bismarck	ND	58505
Scott Larson	ND and SD Field Supervisor	U.S. Fish and Wildlife Service	North Dakota Ecological Services Field Office	3425 Miriam Avenue	Bismarck	ND	58501
Patricia McQueary	Regulatory Program Manager	United States Army Corps of Engineers		1513 South 12th Street	Bismarck	ND	58504
Kyle Wanner	Director	North Dakota Aeronautics Commission		2301 University Dr #22	Bismarck	ND	58504
Terry Steinwand	Director	North Dakota Game and Fish Department		100 E Bismarck Expy	Bismarck	ND	58501
Susan Quinnell	Review and Compliance Coordinator	North Dakota State Historical Society		612 E Boulevard Ave	Bismarck	ND	58505
To Whom It May Concern		North Dakota Department of Trust Lands	Surface Management Division	1707 N 9th St. PO Box 5523	Bismarck	ND	58506
Allisen Bement	Land Professional	North Dakota Departments of Trust Lands	Minerals Management Division	1707 N 9th St. PO Box 5523	Bismarck	ND	58506
		United States Department of Defense		1400 Defense Pentagon	Washington	DC	20301-1400
Thomas Sorel	Director	North Dakota Department of Transportation		608 E Boulevard Ave	Bismarck	ND	58505
Laurie Suttmeier	Manager	North Dakota Federal Aviation Administration		2301 University Dr.	Bismarck	ND	58504

Agency Correspondence



DEPARTMENT OF THE ARMY
CORPS OF ENGINEERS, OMAHA DISTRICT
NORTH DAKOTA REGULATORY OFFICE
3319 UNIVERSITY DRIVE
BISMARCK ND 58504-6640

October 12, 2017

NWO-2017-00021-BIS

Geronimo Energy, LLC
Attn: Ms. Melissa Schmit
7650 Edinborough Way #725
Edina, Minnesota 55435

Dear Ms. Schmit:

This is in response to your solicitation letter dated September 25, 2017 requesting Department of the Army (DA), United States Army Corps of Engineers (Corps) comments on the proposed Harmony Solar ND Project. The project site is located in Sections 10, 11 and 16, Township 140 North, Range 51 West, Cass County, North Dakota.

Corps Regulatory Offices administers Section 404 of the Clean Water Act. Section 404 of the Clean Water Act regulates the discharge of dredge or fill material (temporarily or permanently) in waters of the United States. Waters of the United States may include, but are not limited to, rivers, streams, ditches, coulees, lakes, ponds, and their adjacent wetlands. Fill material includes, but is not limited to, rock, sand, soil, clay, plastics, construction debris, wood chips, overburden from mines or other excavation activities and materials used to create any structure or infrastructure in waters of the United States.

Enclosed for your information is the fact sheet for Nationwide Permit 12, Utility Line Activities. Utility lines are already authorized by Nationwide Permit 12 provided the utility line can be placed without any change to pre-construction contours and all other proposed construction activities and facilities are in compliance with the Nationwide's permit conditions and 401 Water Quality Certification. On Tribal Lands, Water Quality Certification is denied for all Nationwide Permits. Applicants must work with EPA to obtain individual water quality certification. Please note the pre-construction notification requirements on page 2 of the fact sheet. If a project involves any one of the seven notification requirements, the project proponent must submit a DA application. Furthermore, a project must also be in compliance with the "Regional Conditions for Nationwide Permits within the State of North Dakota", found on pages 18 thru 21 of the fact sheet.

In the event your project(s) requires approval from the U.S. Army Corps of Engineers and cannot be authorized by Nationwide Permit(s), a Standard or Individual Permit will be required. A project that requires a Standard or Individual Permit is intensely reviewed and will require the issuance of a public notice. A Standard or Individual Permit generally requires a minimum of 120 days for processing but based on the project impacts and comments received through the public notice may extend well beyond 120 days.

This correspondence letter does not approve the proposed construction work or does not verify the proposed project complies with the Nationwide Permit(s).

If any of these projects require a Section 404 permit, please complete and submit the enclosed Department of the Army permit application (ENG Form 4345) to the U.S. Army Corps of Engineers, North Dakota Regulatory Office, 3319 University Drive, North Dakota 58504 or to the email address below. If you are unsure if a permit is required, you may submit an application; include a project location map, description of work, and construction methodology.

The North Dakota Regulatory office can accept (and prefers) electronic submissions to the following email: CENWO-OD-RND@usace.army.mil.

If we can be of further assistance or should you have any questions regarding our program, please do not hesitate to contact this office by letter or phone at (701) 255-0015.

Sincerely,



Patricia L. McQueary
Regulatory Program Manager
North Dakota

Enclosure
ENG Form 4345
Permit Completion Instructions
Fact Sheet NWP 12

**U.S. ARMY CORPS OF ENGINEERS
APPLICATION FOR DEPARTMENT OF THE ARMY PERMIT**
33 CFR 325. The proponent agency is CECW-CO-R.

*Form Approved -
OMB No. 0710-0003
Expires: 30-SEPTEMBER-2015*

Public reporting for this collection of information is estimated to average 11 hours per response, including the time for reviewing instructions, searching existing data sources, gathering and maintaining the data needed, and completing and reviewing the collection of information. Send comments regarding this burden estimate or any other aspect of the collection of information, including suggestions for reducing this burden, to Department of Defense, Washington Headquarters, Executive Services and Communications Directorate, Information Management Division and to the Office of Management and Budget, Paperwork Reduction Project (0710-0003). Respondents should be aware that notwithstanding any other provision of law, no person shall be subject to any penalty for failing to comply with a collection of information if it does not display a currently valid OMB control number. Please DO NOT RETURN your form to either of those addresses. Completed applications must be submitted to the District Engineer having jurisdiction over the location of the proposed activity.

PRIVACY ACT STATEMENT

Authorities: Rivers and Harbors Act, Section 10, 33 USC 403; Clean Water Act, Section 404, 33 USC 1344; Marine Protection, Research, and Sanctuaries Act, Section 103, 33 USC 1413; Regulatory Programs of the Corps of Engineers; Final Rule 33 CFR 320-332. Principal Purpose: Information provided on this form will be used in evaluating the application for a permit. Routine Uses: This information may be shared with the Department of Justice and other federal, state, and local government agencies, and the public and may be made available as part of a public notice as required by Federal law. Submission of requested information is voluntary, however, if information is not provided the permit application cannot be evaluated nor can a permit be issued. One set of original drawings or good reproducible copies which show the location and character of the proposed activity must be attached to this application (see sample drawings and/or instructions) and be submitted to the District Engineer having jurisdiction over the location of the proposed activity. An application that is not completed in full will be returned.

(ITEMS 1 THRU 4 TO BE FILLED BY THE CORPS)

1. APPLICATION NO.	2. FIELD OFFICE CODE	3. DATE RECEIVED	4. DATE APPLICATION COMPLETE
--------------------	----------------------	------------------	------------------------------

(ITEMS BELOW TO BE FILLED BY APPLICANT)

5. APPLICANT'S NAME First - Middle - Last - Company - E-mail Address -	8. AUTHORIZED AGENT'S NAME AND TITLE (agent is not required) First - Middle - Last - Company - E-mail Address -
6. APPLICANT'S ADDRESS: Address- City - State - Zip - Country -	9. AGENT'S ADDRESS: Address- City - State - Zip - Country -
7. APPLICANT'S PHONE NOs. w/AREA CODE a. Residence b. Business c. Fax	10. AGENTS PHONE NOs. w/AREA CODE a. Residence b. Business c. Fax

STATEMENT OF AUTHORIZATION

11. I hereby authorize, _____ to act in my behalf as my agent in the processing of this application and to furnish, upon request, supplemental information in support of this permit application.

SIGNATURE OF APPLICANT DATE

NAME, LOCATION, AND DESCRIPTION OF PROJECT OR ACTIVITY

12. PROJECT NAME OR TITLE (see instructions)			
13. NAME OF WATERBODY, IF KNOWN (if applicable)		14. PROJECT STREET ADDRESS (if applicable) Address	
15. LOCATION OF PROJECT Latitude: °N Longitude: °W		City -	State- Zip-
16. OTHER LOCATION DESCRIPTIONS, IF KNOWN (see instructions) State Tax Parcel ID Municipality Section - Township - Range -			

17. DIRECTIONS TO THE SITE

18. Nature of Activity (Description of project, include all features)

19. Project Purpose (Describe the reason or purpose of the project, see instructions)

USE BLOCKS 20-23 IF DREDGED AND/OR FILL MATERIAL IS TO BE DISCHARGED

20. Reason(s) for Discharge

21. Type(s) of Material Being Discharged and the Amount of Each Type in Cubic Yards:

Type Amount in Cubic Yards	Type Amount in Cubic Yards	Type Amount in Cubic Yards
-------------------------------	-------------------------------	-------------------------------

22. Surface Area in Acres of Wetlands or Other Waters Filled (see instructions)

Acres
or
Linear Feet

23. Description of Avoidance, Minimization, and Compensation (see instructions)

24. Is Any Portion of the Work Already Complete? Yes No IF YES, DESCRIBE THE COMPLETED WORK

25. Addresses of Adjoining Property Owners, Lessees, Etc., Whose Property Adjoins the Waterbody (if more than can be entered here, please attach a supplemental list).

a. Address-

City - State - Zip -

b. Address-

City - State - Zip -

c. Address-

City - State - Zip -

d. Address-

City - State - Zip -

e. Address-

City - State - Zip -

26. List of Other Certificates or Approvals/Denials received from other Federal, State, or Local Agencies for Work Described in This Application.

AGENCY	TYPE APPROVAL*	IDENTIFICATION NUMBER	DATE APPLIED	DATE APPROVED	DATE DENIED

* Would include but is not restricted to zoning, building, and flood plain permits

27. Application is hereby made for permit or permits to authorize the work described in this application. I certify that this information in this application is complete and accurate. I further certify that I possess the authority to undertake the work described herein or am acting as the duly authorized agent of the applicant.

SIGNATURE OF APPLICANT

DATE

SIGNATURE OF AGENT

DATE

The Application must be signed by the person who desires to undertake the proposed activity (applicant) or it may be signed by a duly authorized agent if the statement in block 11 has been filled out and signed.

18 U.S.C. Section 1001 provides that: Whoever, in any manner within the jurisdiction of any department or agency of the United States knowingly and willfully falsifies, conceals, or covers up any trick, scheme, or disguises a material fact or makes any false, fictitious or fraudulent statements or representations or makes or uses any false writing or document knowing same to contain any false, fictitious or fraudulent statements or entry, shall be fined not more than \$10,000 or imprisoned not more than five years or both.

**Instructions for Preparing a
Department of the Army Permit Application**

Blocks 1 through 4. To be completed by Corps of Engineers.

Block 5. Applicant's Name. Enter the name and the E-mail address of the responsible party or parties. If the responsible party is an agency, company, corporation, or other organization, indicate the name of the organization and responsible officer and title. If more than one party is associated with the application, please attach a sheet with the necessary information marked Block 5.

Block 6. Address of Applicant. Please provide the full address of the party or parties responsible for the application. If more space is needed, attach an extra sheet of paper marked Block 6.

Block 7. Applicant Telephone Number(s). Please provide the number where you can usually be reached during normal business hours.

Blocks 8 through 11. To be completed, if you choose to have an agent.

Block 8. Authorized Agent's Name and Title. Indicate name of individual or agency, designated by you, to represent you in this process. An agent can be an attorney, builder, contractor, engineer, or any other person or organization. Note: An agent is not required.

Blocks 9 and 10. Agent's Address and Telephone Number. Please provide the complete mailing address of the agent, along with the telephone number where he / she can be reached during normal business hours.

Block 11. Statement of Authorization. To be completed by applicant, if an agent is to be employed.

Block 12. Proposed Project Name or Title. Please provide name identifying the proposed project, e.g., Landmark Plaza, Burned Hills Subdivision, or Edsall Commercial Center.

Block 13. Name of Waterbody. Please provide the name of any stream, lake, marsh, or other waterway to be directly impacted by the activity. If it is a minor (no name) stream, identify the waterbody the minor stream enters.

Block 14. Proposed Project Street Address. If the proposed project is located at a site having a street address (not a box number), please enter it here.

Block 15. Location of Proposed Project. Enter the latitude and longitude of where the proposed project is located. If more space is required, please attach a sheet with the necessary information marked Block 15.

Block 16. Other Location Descriptions. If available, provide the Tax Parcel Identification number of the site, Section, Township, and Range of the site (if known), and / or local Municipality that the site is located in.

Block 17. Directions to the Site. Provide directions to the site from a known location or landmark. Include highway and street numbers as well as names. Also provide distances from known locations and any other information that would assist in locating the site. You may also provide description of the proposed project location, such as lot numbers, tract numbers, or you may choose to locate the proposed project site from a known point (such as the right descending bank of Smith Creek, one mile downstream from the Highway 14 bridge). If a large river or stream, include the river mile of the proposed project site if known

Block 18. Nature of Activity. Describe the overall activity or project. Give appropriate dimensions of structures such as wing walls, dikes (identify the materials to be used in construction, as well as the methods by which the work is to be done), or excavations (length, width, and height). Indicate whether discharge of dredged or fill material is involved. Also, identify any structure to be constructed on a fill, piles, or float-supported platforms.

The written descriptions and illustrations are an important part of the application. Please describe, in detail, what you wish to do. If more space is needed, attach an extra sheet of paper marked Block 18.

Block 19. Proposed Project Purpose. Describe the purpose and need for the proposed project. What will it be used for and why? Also include a brief description of any related activities to be developed as the result of the proposed project. Give the approximate dates you plan to both begin and complete all work.

Block 20. Reasons for Discharge. If the activity involves the discharge of dredged and/or fill material into a wetland or other waterbody, including the temporary placement of material, explain the specific purpose of the placement of the material (such as erosion control).

Block 21. Types of Material Being Discharged and the Amount of Each Type in Cubic Yards. Describe the material to be discharged and amount of each material to be discharged within Corps jurisdiction. Please be sure this description will agree with your illustrations. Discharge material includes: rock, sand, clay, concrete, etc.

Block 22. Surface Areas of Wetlands or Other Waters Filled. Describe the area to be filled at each location. Specifically identify the surface areas, or part thereof, to be filled. Also include the means by which the discharge is to be done (backhoe, dragline, etc.). If dredged material is to be discharged on an upland site, identify the site and the steps to be taken (if necessary) to prevent runoff from the dredged material back into a waterbody. If more space is needed, attach an extra sheet of paper marked Block 22.

Block 23. Description of Avoidance, Minimization, and Compensation. Provide a brief explanation describing how impacts to waters of the United States are being avoided and minimized on the project site. Also provide a brief description of how impacts to waters of the United States will be compensated for, or a brief statement explaining why compensatory mitigation should not be required for those impacts.

Block 24. Is Any Portion of the Work Already Complete? Provide any background on any part of the proposed project already completed. Describe the area already developed, structures completed, any dredged or fill material already discharged, the type of material, volume in cubic yards, acres filled, if a wetland or other waterbody (in acres or square feet). If the work was done under an existing Corps permit, identify the authorization, if possible.

Block 25. Names and Addresses of Adjoining Property Owners, Lessees, etc., Whose Property Adjoins the Project Site. List complete names and full mailing addresses of the adjacent property owners (public and private) lessees, etc., whose property adjoins the waterbody or aquatic site where the work is being proposed so that they may be notified of the proposed activity (usually by public notice). If more space is needed, attach an extra sheet of paper marked Block 24.

Information regarding adjacent landowners is usually available through the office of the tax assessor in the county or counties where the project is to be developed.

Block 26. Information about Approvals or Denials by Other Agencies. You may need the approval of other federal, state, or local agencies for your project. Identify any applications you have submitted and the status, if any (approved or denied) of each application. You need not have obtained all other permits before applying for a Corps permit.

Block 27. Signature of Applicant or Agent. The application must be signed by the owner or other authorized party (agent). This signature shall be an affirmation that the party applying for the permit possesses the requisite property rights to undertake the activity applied for (including compliance with special conditions, mitigation, etc.).

DRAWINGS AND ILLUSTRATIONS

General Information.

Three types of illustrations are needed to properly depict the work to be undertaken. These illustrations or drawings are identified as a Vicinity Map, a Plan View or a Typical Cross-Section Map. Identify each illustration with a figure or attachment number.

Please submit one original, or good quality copy, of all drawings on 8½ x11 inch plain white paper (electronic media may be substituted). Use the fewest number of sheets necessary for your drawings or illustrations.

Each illustration should identify the project, the applicant, and the type of illustration (vicinity map, plan view, or cross-section). **While illustrations need not be professional (many small, private project illustrations are prepared by hand), they should be clear, accurate, and contain all necessary information.**

**FACT SHEET
NATIONWIDE PERMIT 12
(2017)**

UTILITY LINE ACTIVITIES

Activities required for the construction, maintenance, repair, and removal of utility lines and associated facilities in waters of the United States, provided the activity does not result in the loss of greater than 1/2-acre of waters of the United States for each single and complete project.

Utility lines: This NWP authorizes discharges of dredged or fill material into waters of the United States and structures or work in navigable waters for crossings of those waters associated with the construction, maintenance, or repair of utility lines, including outfall and intake structures. There must be no change in pre-construction contours of waters of the United States. A “utility line” is defined as any pipe or pipeline for the transportation of any gaseous, liquid, liquescent, or slurry substance, for any purpose, and any cable, line, or wire for the transmission for any purpose of electrical energy, telephone, and telegraph messages, and internet, radio, and television communication. The term “utility line” does not include activities that drain a water of the United States, such as drainage tile or french drains, but it does apply to pipes conveying drainage from another area. Material resulting from trench excavation may be temporarily sidecast into waters of the United States for no more than three months, provided the material is not placed in such a manner that it is dispersed by currents or other forces. The district engineer may extend the period of temporary side casting for no more than a total of 180 days, where appropriate. In wetlands, the top 6 to 12 inches of the trench should normally be backfilled with topsoil from the trench. The trench cannot be constructed or backfilled in such a manner as to drain waters of the United States (e.g., backfilling with extensive gravel layers, creating a french drain effect). Any exposed slopes and stream banks must be stabilized immediately upon completion of the utility line crossing of each waterbody.

Utility line substations: This NWP authorizes the construction, maintenance, or expansion of substation facilities associated with a power line or utility line in non-tidal waters of the United States, provided the activity, in combination with all other activities included in one single and complete project, does not result in the loss of greater than 1/2-acre of waters of the United States. This NWP does not authorize discharges into non-tidal wetlands adjacent to tidal waters of the United States to construct, maintain, or expand substation facilities. **Foundations for overhead utility line towers, poles, and anchors:** This NWP authorizes the construction or maintenance of foundations for overhead utility line towers, poles, and anchors in all waters of the United States, provided the foundations are the minimum size necessary and separate footings for each tower leg (rather than a larger single pad) are used where feasible.

Access roads: This NWP authorizes the construction of access roads for the construction and maintenance of utility lines, including overhead power lines and utility line substations, in non-tidal waters of the United States, provided the activity, in combination with all other activities included in one single and complete project, does not cause the loss of greater than 1/2-acre of non-tidal waters of the United States. This NWP does not authorize discharges into non-tidal wetlands adjacent to tidal waters for access roads. Access roads must be the minimum width necessary (see Note 2, below). Access roads must be constructed so that the length of the road minimizes any adverse effects on waters of the United States and must be as near as possible to pre-construction contours and elevations (e.g., at grade corduroy roads or

geotextile/gravel roads). Access roads constructed above pre-construction contours and elevations in waters of the United States must be properly bridged or culverted to maintain surface flows. This NWP may authorize utility lines in or affecting navigable waters of the United States even if there is no associated discharge of dredged or fill material (See 33 CFR part 322). Overhead utility lines constructed over section 10 waters and utility lines that are routed in or under section 10 waters without a discharge of dredged or fill material require a section 10 permit. This NWP authorizes, to the extent that Department of the Army authorization is required, temporary structures, fills, and work necessary for the remediation of inadvertent returns of drilling fluids to waters of the United States through sub-soil fissures or fractures that might occur during horizontal directional drilling activities conducted for the purpose of installing or replacing utility lines. These remediation activities must be done as soon as practicable, to restore the affected waterbody. District engineers may add special conditions to this NWP to require a remediation plan for addressing inadvertent returns of drilling fluids to waters of the United States during horizontal directional drilling activities conducted for the purpose of installing or replacing utility lines. This NWP also authorizes temporary structures, fills, and work, including the use of temporary mats, necessary to conduct the utility line activity. Appropriate measures must be taken to maintain normal downstream flows and minimize flooding to the maximum extent practicable, when temporary structures, work, and discharges, including cofferdams, are necessary for construction activities, access fills, or dewatering of construction sites. Temporary fills must consist of materials, and be placed in a manner, that will not be eroded by expected high flows. After construction, temporary fills must be removed in their entirety and the affected areas returned to pre- construction elevations. The areas affected by temporary fills must be revegetated, as appropriate.

Notification: The permittee must submit a pre-construction notification to the district engineer prior to commencing the activity if any of the following criteria are met: (1) The activity involves mechanized land clearing in a forested wetland for the utility line right-of-way; (2) a section 10 permit is required; (3) the utility line in waters of the United States, excluding overhead lines, exceeds 500 feet; (4) the utility line is placed within a jurisdictional area (i.e., water of the United States), and it runs parallel to or along a stream bed that is within that jurisdictional area; (5) discharges that result in the loss of greater than 1/10- acre of waters of the United States; (6) permanent access roads are constructed above grade in waters of the United States for a distance of more than 500 feet; or (7) permanent access roads are constructed in waters of the United States with impervious materials. (See general condition 32.) (Sections 10 and 404)

Note 1: Where the utility line is constructed or installed in navigable waters of the United States (i.e., section 10 waters) within the coastal United States, the Great Lakes, and United States territories, a copy of the NWP verification will be sent by the Corps to the National Oceanic and Atmospheric Administration (NOAA), National Ocean Service (NOS), for charting the utility line to protect navigation.

Note 2: For utility line activities crossing a single waterbody more than one time at separate and distant locations, or multiple waterbodies at separate and distant locations, each crossing is considered a single and complete project for purposes of NWP authorization. Utility line activities must comply with 33 CFR 330.6(d).

Note 3: Utility lines consisting of aerial electric power transmission lines crossing navigable waters of the United States (which are defined at 33 CFR part 329) must comply with the applicable minimum clearances specified in 33 CFR 322.5(i).

Note 4: Access roads used for both construction and maintenance may be authorized, provided they meet the terms and conditions of this NWP. Access roads used solely for construction of the utility line must be removed upon completion of the work, in accordance with the requirements for temporary fills.

Note 5: Pipes or pipelines used to transport gaseous, liquid, liquescent, or slurry substances over navigable waters of the United States are considered to be bridges, not utility lines, and may require a permit from the U.S. Coast Guard pursuant to section 9 of the Rivers and Harbors Act of 1899. However, any discharges of dredged or fill material into waters of the United States associated with such pipelines will require a section 404 permit (see NWP 15).

Note 6: This NWP authorizes utility line maintenance and repair activities that do not qualify for the Clean Water Act section 404(f) exemption for maintenance of currently serviceable fills or fill structures.

Note 7: For overhead utility lines authorized by this NWP, a copy of the PCN and NWP verification will be provided to the Department of Defense Siting Clearinghouse, which will evaluate potential effects on military activities.

Note 8: For NWP 12 activities that require pre-construction notification, the PCN must include any other NWP(s), regional general permit(s), or individual permit(s) used or intended to be used to authorize any part of the proposed project or any related activity, including other separate and distant crossings that require Department of the Army authorization but do not require pre-construction notification (see paragraph (b) of general condition 32). The district engineer will evaluate the PCN in accordance with Section D, "District Engineer's Decision." The district engineer may require mitigation to ensure that the authorized activity results in no more than minimal individual and cumulative adverse environmental effects (see general condition 23).

Nationwide Permit General Conditions

Note: To qualify for NWP authorization, the prospective permittee must comply with the following general conditions, as applicable, in addition to any regional or case-specific conditions imposed by the division engineer or district engineer. Prospective permittees should contact the appropriate Corps district office to determine if regional conditions have been imposed on an NWP. Prospective permittees should also contact the appropriate Corps district office to determine the status of Clean Water Act Section 401 water quality certification and/or Coastal Zone Management Act consistency for an NWP. Every person who may wish to obtain permit authorization under one or more NWPs, or who is currently relying on an existing or prior permit authorization under one or more NWPs, has been and is on notice that all of the provisions of 33 CFR 330.1 through 330.6 apply to every NWP authorization. Note especially 33 CFR 330.5 relating to the modification, suspension, or revocation of any NWP authorization.

1. Navigation.

(a) No activity may cause more than a minimal adverse effect on navigation.

(b) Any safety lights and signals prescribed by the U.S. Coast Guard, through regulations or otherwise, must be installed and maintained at the permittee's expense on authorized facilities in navigable waters of the United States.

(c) The permittee understands and agrees that, if future operations by the United States require the removal, relocation, or other alteration, of the structure or work herein authorized, or if, in the opinion of the Secretary of the Army or his authorized representative, said structure or work shall cause unreasonable obstruction to the free navigation of the navigable waters, the permittee will be required, upon due notice from the Corps of Engineers, to remove, relocate, or alter the structural work or obstructions caused thereby, without expense to the United States. No claim shall be made against the United States on account of any such removal or alteration.

2. Aquatic Life Movements.

No activity may substantially disrupt the necessary life cycle movements of those species of aquatic life indigenous to the waterbody, including those species that normally migrate through the area, unless the activity's primary purpose is to impound water. All permanent and temporary crossings of waterbodies shall be suitably culverted, bridged, or otherwise designed and constructed to maintain low flows to sustain the movement of those aquatic species. If a bottomless culvert cannot be used, then the crossing should be designed and constructed to minimize adverse effects to aquatic life movements.

3. Spawning Areas.

Activities in spawning areas during spawning seasons must be avoided to the maximum extent practicable. Activities that result in the physical destruction (e.g., through excavation, fill, or downstream smothering by substantial turbidity) of an important spawning area are not authorized.

4. Migratory Bird Breeding Areas.

Activities in waters of the United States that serve as breeding areas for migratory birds must be avoided to the maximum extent practicable.

5. Shellfish Beds.

No activity may occur in areas of concentrated shellfish populations, unless the activity is directly related to a shellfish harvesting activity authorized by NWP 4 and 48, or is a shellfish seeding or habitat restoration activity authorized by NWP 27.

6. Suitable Material.

No activity may use unsuitable material (e.g., trash, debris, car bodies, asphalt, etc.). Material used for construction or discharged must be free from toxic pollutants in toxic amounts (see section 307 of the Clean Water Act).

7. Water Supply Intakes.

No activity may occur in the proximity of a public water supply intake, except where the activity is for the repair or improvement of public water supply intake structures or adjacent bank stabilization.

8. Adverse Effects from Impoundments.

If the activity creates an impoundment of water, adverse effects to the aquatic system due to accelerating the passage of water, and/or restricting its flow must be minimized to the maximum extent practicable.

9. Management of Water Flows.

To the maximum extent practicable, the pre-construction course, condition, capacity, and location of open waters must be maintained for each activity, including stream channelization, storm water management activities, and temporary and permanent road crossings, except as provided below. The activity must be constructed to withstand expected high flows. The activity must not restrict or impede the passage of normal or high flows, unless the primary purpose of the activity is to impound water or manage high flows. The activity may alter the pre-construction course, condition, capacity, and location of open waters if it benefits the aquatic environment (e.g., stream restoration or relocation activities).

10. Fills Within 100-Year Floodplains.

The activity must comply with applicable FEMA-approved state or local floodplain management requirements.

11. Equipment.

Heavy equipment working in wetlands or mudflats must be placed on mats, or other measures must be taken to minimize soil disturbance.

12. Soil Erosion and Sediment Controls.

Appropriate soil erosion and sediment controls must be used and maintained in effective operating condition during construction, and all exposed soil and other fills, as well as any work below the ordinary high water mark or high tide line, must be permanently stabilized at the earliest practicable date. Permittees are encouraged to perform work within waters of the United States during periods of low-flow or no-flow, or during low tides.

13. Removal of Temporary Fills.

Temporary fills must be removed in their entirety and the affected areas returned to pre-construction elevations. The affected areas must be revegetated, as appropriate.

14. Proper Maintenance.

Any authorized structure or fill shall be properly maintained, including maintenance to ensure public safety and compliance with applicable NWP general conditions, as well as any activity-specific conditions added by the district engineer to an NWP authorization.

15. Single and Complete Project.

The activity must be a single and complete project. The same NWP cannot be used more than once for the same single and complete project.

16. Wild and Scenic Rivers.

(a) No NWP activity may occur in a component of the National Wild and Scenic River System, or in a river officially designated by Congress as a “study river” for possible inclusion in the system while the river is in an official study status, unless the appropriate Federal agency with direct management responsibility for such river, has determined in writing that the proposed activity will not adversely affect the Wild and Scenic River designation or study status.

(b) If a proposed NWP activity will occur in a component of the National Wild and Scenic River System, or in a river officially designated by Congress as a “study river” for possible inclusion in the system while the river is in an official study status, the permittee must submit a pre-construction notification (see general condition 32). The district engineer will coordinate the PCN with the Federal agency with direct management responsibility for that river. The permittee shall not begin the NWP activity until notified by the district engineer that the Federal agency with direct management responsibility for that river has determined in writing that the proposed NWP activity will not adversely affect the Wild and Scenic River designation or study status.

(c) Information on Wild and Scenic Rivers may be obtained from the appropriate Federal land management agency responsible for the designated Wild and Scenic River or study river (e.g., National Park Service, U.S. Forest Service, Bureau of Land Management, U.S. Fish and Wildlife Service). Information on these rivers is also available at: <http://www.rivers.gov/>.

17. Tribal Rights.

No NWP activity may cause more than minimal adverse effects on tribal rights (including treaty rights), protected tribal resources, or tribal lands.

18. Endangered Species.

(a) No activity is authorized under any NWP which is likely to directly or indirectly jeopardize the continued existence of a threatened or endangered species or a species proposed for such designation, as identified under the Federal Endangered Species Act (ESA), or which will

directly or indirectly destroy or adversely modify the critical habitat of such species. No activity is authorized under any NWP which “may affect” a listed species or critical habitat, unless ESA section 7 consultation addressing the effects of the proposed activity has been completed. Direct effects are the immediate effects on listed species and critical habitat caused by the NWP activity. Indirect effects are those effects on listed species and critical habitat that are caused by the NWP activity and are later in time, but still are reasonably certain to occur.

(b) Federal agencies should follow their own procedures for complying with the requirements of the ESA. If pre- construction notification is required for the proposed activity, the Federal permittee must provide the district engineer with the appropriate documentation to demonstrate compliance with those requirements. The district engineer will verify that the appropriate documentation has been submitted. If the appropriate documentation has not been submitted, additional ESA section 7 consultation may be necessary for the activity and the respective federal agency would be responsible for fulfilling its obligation under section 7 of the ESA.

(c) Non-federal permittees must submit a pre-construction notification to the district engineer if any listed species or designated critical habitat might be affected or is in the vicinity of the activity, or if the activity is located in designated critical habitat, and shall not begin work on the activity until notified by the district engineer that the requirements of the ESA have been satisfied and that the activity is authorized. For activities that might affect Federally-listed endangered or threatened species or designated critical habitat, the pre-construction notification must include the name(s) of the endangered or threatened species that might be affected by the proposed activity or that utilize the designated critical habitat that might be affected by the proposed activity. The district engineer will determine whether the proposed activity “may affect” or will have “no effect” to listed species and designated critical habitat and will notify the non-Federal applicant of the Corps’ determination within 45 days of receipt of a complete pre-construction notification. In cases where the non- Federal applicant has identified listed species or critical habitat that might be affected or is in the vicinity of the activity, and has so notified the Corps, the applicant shall not begin work until the Corps has provided notification that the proposed activity will have “no effect” on listed species or critical habitat, or until ESA section 7 consultation has been completed. If the non-Federal applicant has not heard back from the Corps within 45 days, the applicant must still wait for notification from the Corps.

(d) As a result of formal or informal consultation with the FWS or NMFS the district engineer may add species- specific permit conditions to the NWPs.

(e) Authorization of an activity by an NWP does not authorize the “take” of a threatened or endangered species as defined under the ESA. In the absence of separate authorization (e.g., an ESA Section 10 Permit, a Biological Opinion with “incidental take” provisions, etc.) from the FWS or the NMFS, the Endangered Species Act prohibits any person subject to the jurisdiction of the United States to take a listed species, where “take” means to harass, harm, pursue, hunt, shoot, wound, kill, trap, capture, or collect, or to attempt to engage in any such conduct. The word “harm” in the definition of “take” means an act which actually kills or injures wildlife. Such an act may include significant habitat modification or degradation where it actually kills or injures wildlife by significantly impairing essential behavioral patterns, including breeding, feeding or sheltering.

(f) If the non-federal permittee has a valid ESA section 10(a)(1)(B) incidental take permit with an approved Habitat Conservation Plan for a project or a group of projects that includes the proposed NWP activity, the non-federal applicant should provide a copy of that ESA section 10(a)(1)(B) permit with the PCN required by paragraph (c) of this general condition. The district

engineer will coordinate with the agency that issued the ESA section 10(a)(1)(B) permit to determine whether the proposed NWP activity and the associated incidental take were considered in the internal ESA section 7 consultation conducted for the ESA section 10(a)(1)(B) permit. If that coordination results in concurrence from the agency that the proposed NWP activity and the associated incidental take were considered in the internal ESA section 7 consultation for the ESA section 10(a)(1)(B) permit, the district engineer does not need to conduct a separate ESA section 7 consultation for the proposed NWP activity. The district engineer will notify the non-federal applicant within 45 days of receipt of a complete pre-construction notification whether the ESA section 10(a)(1)(B) permit covers the proposed NWP activity or whether additional ESA section 7 consultation is required.

(g) Information on the location of threatened and endangered species and their critical habitat can be obtained directly from the offices of the FWS and NMFS or their world wide Web pages at <http://www.fws.gov/> or <http://www.fws.gov/ipac> and <http://www.nmfs.noaa.gov/pr/species/esa/> respectively.

19. Migratory Birds and Bald and Golden Eagles.

The permittee is responsible for ensuring their action complies with the Migratory Bird Treaty Act and the Bald and Golden Eagle Protection Act. The permittee is responsible for contacting appropriate local office of the U.S. Fish and Wildlife Service to determine applicable measures to reduce impacts to migratory birds or eagles, including whether “incidental take” permits are necessary and available under the Migratory Bird Treaty Act or Bald and Golden Eagle Protection Act for a particular activity.

20. Historic Properties.

(a) In cases where the district engineer determines that the activity may have the potential to cause effects to properties listed, or eligible for listing, in the National Register of Historic Places, the activity is not authorized, until the requirements of Section 106 of the National Historic Preservation Act (NHPA) have been satisfied.

(b) Federal permittees should follow their own procedures for complying with the requirements of section 106 of the National Historic Preservation Act. If pre-construction notification is required for the proposed NWP activity, the Federal permittee must provide the district engineer with the appropriate documentation to demonstrate compliance with those requirements. The district engineer will verify that the appropriate documentation has been submitted. If the appropriate documentation is not submitted, then additional consultation under section 106 may be necessary. The respective federal agency is responsible for fulfilling its obligation to comply with section 106.

(c) Non-federal permittees must submit a pre-construction notification to the district engineer if the NWP activity might have the potential to cause effects to any historic properties listed on, determined to be eligible for listing on, or potentially eligible for listing on the National Register of Historic Places, including previously unidentified properties. For such activities, the pre-construction notification must state which historic properties might have the potential to be affected by the proposed NWP activity or include a vicinity map indicating the location of the historic properties or the potential for the presence of historic properties. Assistance regarding information on the location of, or potential for, the presence of historic properties can be sought

from the State Historic Preservation Officer, Tribal Historic Preservation Officer, or designated tribal representative, as appropriate, and the National Register of Historic Places (see 33 CFR 330.4(g)). When reviewing pre-construction notifications, district engineers will comply with the current procedures for addressing the requirements of section 106 of the National Historic Preservation Act. The district engineer shall make a reasonable and good faith effort to carry out appropriate identification efforts, which may include background research, consultation, oral history interviews, sample field investigation, and field survey. Based on the information submitted in the PCN and these identification efforts, the district engineer shall determine whether the proposed NWP activity has the potential to cause effects on the historic properties. Section 106 consultation is not required when the district engineer determines that the activity does not have the potential to cause effects on historic properties (see 36 CFR 800.3(a)). Section 106 consultation is required when the district engineer determines that the activity has the potential to cause effects on historic properties. The district engineer will conduct consultation with consulting parties identified under 36 CFR 800.2(c) when he or she makes any of the following effect determinations for the purposes of section 106 of the NHPA: no historic properties affected, no adverse effect, or adverse effect. Where the non-Federal applicant has identified historic properties on which the activity might have the potential to cause effects and so notified the Corps, the non-Federal applicant shall not begin the activity until notified by the district engineer either that the activity has no potential to cause effects to historic properties or that NHPA section 106 consultation has been completed.

(d) For non-federal permittees, the district engineer will notify the prospective permittee within 45 days of receipt of a complete pre-construction notification whether NHPA section 106 consultation is required. If NHPA section 106 consultation is required, the district engineer will notify the non-Federal applicant that he or she cannot begin the activity until section 106 consultation is completed. If the non-Federal applicant has not heard back from the Corps within 45 days, the applicant must still wait for notification from the Corps.

(e) Prospective permittees should be aware that section 110k of the NHPA (54 U.S.C. 306113) prevents the Corps from granting a permit or other assistance to an applicant who, with intent to avoid the requirements of section 106 of the NHPA, has intentionally significantly adversely affected a historic property to which the permit would relate, or having legal power to prevent it, allowed such significant adverse effect to occur, unless the Corps, after consultation with the Advisory Council on Historic Preservation (ACHP), determines that circumstances justify granting such assistance despite the adverse effect created or permitted by the applicant. If circumstances justify granting the assistance, the Corps is required to notify the ACHP and provide documentation specifying the circumstances, the degree of damage to the integrity of any historic properties affected, and proposed mitigation. This documentation must include any views obtained from the applicant, SHPO/ THPO, appropriate Indian tribes if the undertaking occurs on or affects historic properties on tribal lands or affects properties of interest to those tribes, and other parties known to have a legitimate interest in the impacts to the permitted activity on historic properties.

21. Discovery of Previously Unknown Remains and Artifacts.

If you discover any previously unknown historic, cultural or archeological remains and artifacts while accomplishing the activity authorized by this permit, you must immediately notify the district engineer of what you have found, and to the maximum extent practicable, avoid

construction activities that may affect the remains and artifacts until the required coordination has been completed. The district engineer will initiate the Federal, Tribal, and state coordination required to determine if the items or remains warrant a recovery effort or if the site is eligible for listing in the National Register of Historic Places.

22. Designated Critical Resource Waters.

Critical resource waters include, NOAA-managed marine sanctuaries and marine monuments, and National Estuarine Research Reserves. The district engineer may designate, after notice and opportunity for public comment, additional waters officially designated by a state as having particular environmental or ecological significance, such as outstanding national resource waters or state natural heritage sites. The district engineer may also designate additional critical resource waters after notice and opportunity for public comment.

- (a) Discharges of dredged or fill material into waters of the United States are not authorized by NWP's 7, 12, 14, 16, 17, 21, 29, 31, 35, 39, 40, 42, 43, 44, 49, 50, 51, and 52 for any activity within, or directly affecting, critical resource waters, including wetlands adjacent to such waters.
- (b) For NWP's 3, 8, 10, 13, 15, 18, 19, 22, 23, 25, 27, 28, 30, 33, 34, 36, 37, 38, and 54, notification is required in accordance with general condition 32, for any activity proposed in the designated critical resource waters including wetlands adjacent to those waters. The district engineer may authorize activities under these NWP's only after it is determined that the impacts to the critical resource waters will be no more than minimal.

23. Mitigation.

The district engineer will consider the following factors when determining appropriate and practicable mitigation necessary to ensure that the individual and cumulative adverse environmental effects are no more than minimal:

- (a) The activity must be designed and constructed to avoid and minimize adverse effects, both temporary and permanent, to waters of the United States to the maximum extent practicable at the project site (i.e., on site).
- (b) Mitigation in all its forms (avoiding, minimizing, rectifying, reducing, or compensating for resource losses) will be required to the extent necessary to ensure that the individual and cumulative adverse environmental effects are no more than minimal.
- (c) Compensatory mitigation at a minimum one-for-one ratio will be required for all wetland losses that exceed 1/10-acre and require pre- construction notification, unless the district engineer determines in writing that either some other form of mitigation would be more environmentally appropriate or the adverse environmental effects of the proposed activity are no more than minimal, and provides an activity-specific waiver of this requirement. For wetland losses of 1/10-acre or less that require pre- construction notification, the district engineer may determine on a case-by- case basis that compensatory mitigation is required to ensure that the activity results in only minimal adverse environmental effects.
- (d) For losses of streams or other open waters that require pre-construction notification, the district engineer may require compensatory mitigation to ensure that the activity results in no more than minimal adverse environmental effects. Compensatory mitigation for losses of streams should be provided, if practicable, through stream rehabilitation, enhancement, or preservation, since streams are difficult- to-replace resources (see 33 CFR 332.3(e)(3)).

(e) Compensatory mitigation plans for NWP activities in or near streams or other open waters will normally include a requirement for the restoration or enhancement, maintenance, and legal protection (e.g., conservation easements) of riparian areas next to open waters. In some cases, the restoration or maintenance/protection of riparian areas may be the only compensatory mitigation required. Restored riparian areas should consist of native species. The width of the required riparian area will address documented water quality or aquatic habitat loss concerns.

Normally, the riparian area will be 25 to 50 feet wide on each side of the stream, but the district engineer may require slightly wider riparian areas to address documented water quality or habitat loss concerns. If it is not possible to restore or maintain/protect a riparian area on both sides of a stream, or if the waterbody is a lake or coastal waters, then restoring or maintaining/protecting a riparian area along a single bank or shoreline may be sufficient. Where both wetlands and open waters exist on the project site, the district engineer will determine the appropriate compensatory mitigation (e.g., riparian areas and/or wetlands compensation) based on what is best for the aquatic environment on a watershed basis. In cases where riparian areas are determined to be the most appropriate form of minimization or compensatory mitigation, the district engineer may waive or reduce the requirement to provide wetland compensatory mitigation for wetland losses.

(f) Compensatory mitigation projects provided to offset losses of aquatic resources must comply with the applicable provisions of 33 CFR part 332.

(1) The prospective permittee is responsible for proposing an appropriate compensatory mitigation option if compensatory mitigation is necessary to ensure that the activity results in no more than minimal adverse environmental effects. For the NWPs, the preferred mechanism for providing compensatory mitigation is mitigation bank credits or in-lieu fee program credits (see 33 CFR 332.3(b)(2) and (3)). However, if an appropriate number and type of mitigation bank or in-lieu credits are not available at the time the PCN is submitted to the district engineer, the district engineer may approve the use of permittee-responsible mitigation.

(2) The amount of compensatory mitigation required by the district engineer must be sufficient to ensure that the authorized activity results in no more than minimal individual and cumulative adverse environmental effects (see 33 CFR 330.1(e)(3)). (See also 33 CFR 332.3(f)).

(3) Since the likelihood of success is greater and the impacts to potentially valuable uplands are reduced, aquatic resource restoration should be the first compensatory mitigation option considered for permittee-responsible mitigation.

(4) If permittee-responsible mitigation is the proposed option, the prospective permittee is responsible for submitting a mitigation plan. A conceptual or detailed mitigation plan may be used by the district engineer to make the decision on the NWP verification request, but a final mitigation plan that addresses the applicable requirements of 33 CFR 332.4(c)(2) through (14) must be approved by the district engineer before the permittee begins work in waters of the United States, unless the district engineer determines that prior approval of the final mitigation plan is not practicable or not necessary to ensure timely completion of the required compensatory mitigation (see 33 CFR 332.3(k)(3)).

(5) If mitigation bank or in-lieu fee program credits are the proposed option, the mitigation plan only needs to address the baseline conditions at the impact site and the number of credits to be provided.

(6) Compensatory mitigation requirements (e.g., resource type and amount to be provided as compensatory mitigation, site protection, ecological performance standards, monitoring requirements) may be addressed through conditions added to the NWP authorization, instead of components of a compensatory mitigation plan (see 33 CFR 332.4(c)(1)(ii)).

(g) Compensatory mitigation will not be used to increase the acreage losses allowed by the acreage limits of the NWP. For example, if an NWP has an acreage limit of 1/2-acre, it cannot be used to authorize any NWP activity resulting in the loss of greater than 1/2- acre of waters of the United States, even if compensatory mitigation is provided that replaces or restores some of the lost waters. However, compensatory mitigation can and should be used, as necessary, to ensure that an NWP activity already meeting the established acreage limits also satisfies the no more than minimal impact requirement for the NWPs.

(h) Permittees may propose the use of mitigation banks, in-lieu fee programs, or permittee-responsible mitigation. When developing a compensatory mitigation proposal, the permittee must consider appropriate and practicable options consistent with the framework at 33 CFR 332.3(b). For activities resulting in the loss of marine or estuarine resources, permittee-responsible mitigation may be environmentally preferable if there are no mitigation banks or in-lieu fee programs in the area that have marine or estuarine credits available for sale or transfer to the permittee. For permittee- responsible mitigation, the special conditions of the NWP verification must clearly indicate the party or parties responsible for the implementation and performance of the compensatory mitigation project, and, if required, its long-term management.

(i) Where certain functions and services of waters of the United States are permanently adversely affected by a regulated activity, such as discharges of dredged or fill material into waters of the United States that will convert a forested or scrub-shrub wetland to a herbaceous wetland in a permanently maintained utility line right-of-way, mitigation may be required to reduce the adverse environmental effects of the activity to the no more than minimal level.

24. Safety of Impoundment Structures.

To ensure that all impoundment structures are safely designed, the district engineer may require non-Federal applicants to demonstrate that the structures comply with established state dam safety criteria or have been designed by qualified persons. The district engineer may also require documentation that the design has been independently reviewed by similarly qualified persons, and appropriate modifications made to ensure safety.

25. Water Quality.

Where States and authorized Tribes, or EPA where applicable, have not previously certified compliance of an NWP with CWA section 401, individual 401 Water Quality Certification must be obtained or waived (see 33 CFR 330.4(c)). The district engineer or State or Tribe may require additional water quality management measures to ensure that the authorized activity does not result in more than minimal degradation of water quality. *Specifically for North Dakota, the North Dakota Department of Health has denied water quality certification for all projects proposed to affect Class 1 and 1A, II and Class III rivers and streams or classified lakes listed in Appendices I and II of the standards, individual certification must be obtained. For project proposed to affect any other waters, the North Dakota Department of Health has issued water quality certification provided the attached Construction and Environmental Disturbance Requirements are followed. The Standards may be found at <http://www.legis.nd.gov/information/acdata/pdf/33-16-02.1.pdf?2016031115632> On Tribal Lands, Water Quality Certification is denied for all Nationwide Permits. Applicants must work with EPA to obtain individual water quality certification. Contact: USEPA, Region 8,*

401 Certification Program – 8WP-AAP, 1595 Wynkoop Street, Denver, Colorado 80202-1129.
(303-312-6909)

26. Coastal Zone Management.

In coastal states where an NWP has not previously received a state coastal zone management consistency concurrence, an individual state coastal zone management consistency concurrence must be obtained, or a presumption of concurrence must occur (see 33 CFR 330.4(d)). The district engineer or a State may require additional measures to ensure that the authorized activity is consistent with state coastal zone management requirements.

27. Regional and Case-By-Case Conditions.

The activity must comply with any regional conditions that may have been added by the Division Engineer (see 33 CFR 330.4(e)) and with any case specific conditions added by the Corps or by the state, Indian Tribe, or U.S. EPA in its section 401 Water Quality Certification, or by the state in its Coastal Zone Management Act consistency determination.

28. Use of Multiple Nationwide Permits.

The use of more than one NWP for a single and complete project is prohibited, except when the acreage loss of waters of the United States authorized by the NWPs does not exceed the acreage limit of the NWP with the highest specified acreage limit. For example, if a road crossing over tidal waters is constructed under NWP 14, with associated bank stabilization authorized by NWP 13, the maximum acreage loss of waters of the United States for the total project cannot exceed 1/3-acre.

29. Transfer of Nationwide Permit Verifications.

If the permittee sells the property associated with a nationwide permit verification, the permittee may transfer the nationwide permit verification to the new owner by submitting a letter to the appropriate Corps district office to validate the transfer. A copy of the nationwide permit verification must be attached to the letter, and the letter must contain the following statement and signature:

When the structures or work authorized by this nationwide permit are still in existence at the time the property is transferred, the terms and conditions of this nationwide permit, including any special conditions, will continue to be binding on the new owner(s) of the property. To validate the transfer of this nationwide permit and the associated liabilities associated with compliance with its terms and conditions, have the transferee sign and date below.

_____ (Transferee) _____ (Date)

30. Compliance Certification.

Each permittee who receives an NWP verification letter from the Corps must provide a signed certification documenting completion of the authorized activity and implementation of any required compensatory mitigation. The success of any required permittee-responsible mitigation, including the achievement of ecological performance standards, will be addressed separately by the district engineer. The Corps will provide the permittee the certification document with the NWP verification letter. The certification document will include:

- (a) A statement that the authorized activity was done in accordance with the NWP authorization, including any general, regional, or activity-specific conditions;
- (b) A statement that the implementation of any required compensatory mitigation was completed in accordance with the permit conditions. If credits from a mitigation bank or in-lieu fee program are used to satisfy the compensatory mitigation requirements, the certification must include the documentation required by 33 CFR 332.3(l)(3) to confirm that the permittee secured the appropriate number and resource type of credits; and
- (c) The signature of the permittee certifying the completion of the activity and mitigation. The completed certification document must be submitted to the district engineer within 30 days of completion of the authorized activity or the implementation of any required compensatory mitigation, whichever occurs later.

31. Activities Affecting Structures or Works Built by the United States.

If an NWP activity also requires permission from the Corps pursuant to 33 U.S.C. 408 because it will alter or temporarily or permanently occupy or use a U.S. Army Corps of Engineers (USACE) federally authorized Civil Works project (a “USACE project”), the prospective permittee must submit a pre- construction notification. See paragraph (b)(10) of general condition 32. An activity that requires section 408 permission is not authorized by NWP until the appropriate Corps office issues the section 408 permission to alter, occupy, or use the USACE project, and the district engineer issues a written NWP verification.

32. Pre-Construction Notification.

(a) Timing. Where required by the terms of the NWP, the prospective permittee must notify the district engineer by submitting a pre-construction notification (PCN) as early as possible. The district engineer must determine if the PCN is complete within 30 calendar days of the date of receipt and, if the PCN is determined to be incomplete, notify the prospective permittee within that 30 day period to request the additional information necessary to make the PCN complete. The request must specify the information needed to make the PCN complete. As a general rule, district engineers will request additional information necessary to make the PCN complete only once. However, if the prospective permittee does not provide all of the requested information, then the district engineer will notify the prospective permittee that the PCN is still incomplete and the PCN review process will not commence until all of the requested information has been received by the district engineer. The prospective permittee shall not begin the activity until either:

- (1) He or she is notified in writing by the district engineer that the activity may proceed under the NWP with any special conditions imposed by the district or division engineer; or
- (2) 45 calendar days have passed from the district engineer’s receipt of the complete PCN and the prospective permittee has not received written notice from the district or division

engineer. However, if the permittee was required to notify the Corps pursuant to general condition 18 that listed species or critical habitat might be affected or are in the vicinity of the activity, or to notify the Corps pursuant to general condition 20 that the activity might have the potential to cause effects to historic properties, the permittee cannot begin the activity until receiving written notification from the Corps that there is “no effect” on listed species or “no potential to cause effects” on historic properties, or that any consultation required under Section 7 of the Endangered Species Act (see 33 CFR 330.4(f)) and/or section 106 of the National Historic Preservation Act (see 33 CFR 330.4(g)) has been completed. Also, work cannot begin under NWP 21, 49, or 50 until the permittee has received written approval from the Corps. If the proposed activity requires a written waiver to exceed specified limits of an NWP, the permittee may not begin the activity until the district engineer issues the waiver. If the district or division engineer notifies the permittee in writing that an individual permit is required within 45 calendar days of receipt of a complete PCN, the permittee cannot begin the activity until an individual permit has been obtained. Subsequently, the permittee’s right to proceed under the NWP may be modified, suspended, or revoked only in accordance with the procedure set forth in 33 CFR 330.5(d)(2).

(b) Contents of Pre-Construction Notification: The PCN must be in writing and include the following information:

- (1) Name, address and telephone numbers of the prospective permittee;
- (2) Location of the proposed activity;
- (3) Identify the specific NWP or NWP(s) the prospective permittee wants to use to authorize the proposed activity;
- (4) A description of the proposed activity; the activity’s purpose; direct and indirect adverse environmental effects the activity would cause, including the anticipated amount of loss of wetlands, other special aquatic sites, and other waters expected to result from the NWP activity, in acres, linear feet, or other appropriate unit of measure; a description of any proposed mitigation measures intended to reduce the adverse environmental effects caused by the proposed activity; and any other NWP(s), regional general permit(s), or individual permit(s) used or intended to be used to authorize any part of the proposed project or any related activity, including other separate and distant crossings for linear projects that require Department of the Army authorization but do not require pre-construction notification. The description of the proposed activity and any proposed mitigation measures should be sufficiently detailed to allow the district engineer to determine that the adverse environmental effects of the activity will be no more than minimal and to determine the need for compensatory mitigation or other mitigation measures. For single and complete linear projects, the PCN must include the quantity of anticipated losses of wetlands, other special aquatic sites, and other waters for each single and complete crossing of those wetlands, other special aquatic sites, and other waters. Sketches should be provided when necessary to show that the activity complies with the terms of the NWP. (Sketches usually clarify the activity and when provided results in a quicker decision. Sketches should contain sufficient detail to provide an illustrative description of the proposed activity (e.g., a conceptual plan), but do not need to be detailed engineering plans);
- (5) The PCN must include a delineation of wetlands, other special aquatic sites, and other waters, such as lakes and ponds, and perennial, intermittent, and ephemeral streams, on the project site. Wetland delineations must be prepared in accordance with the current method required by the Corps. The permittee may ask the Corps to delineate the special aquatic sites and other waters on the project site, but there may be a delay if the Corps does the delineation,

especially if the project site is large or contains many wetlands, other special aquatic sites, and other waters. Furthermore, the 45 day period will not start until the delineation has been submitted to or completed by the Corps, as appropriate;

(6) If the proposed activity will result in the loss of greater than 1/10-acre of wetlands and a PCN is required, the prospective permittee must submit a statement describing how the mitigation requirement will be satisfied, or explaining why the adverse environmental effects are no more than minimal and why compensatory mitigation should not be required. As an alternative, the prospective permittee may submit a conceptual or detailed mitigation plan.

(7) For non-Federal permittees, if any listed species or designated critical habitat might be affected or is in the vicinity of the activity, or if the activity is located in designated critical habitat, the PCN must include the name(s) of those endangered or threatened species that might be affected by the proposed activity or utilize the designated critical habitat that might be affected by the proposed activity. For NWP activities that require pre-construction notification, Federal permittees must provide documentation demonstrating compliance with the Endangered Species Act.

(8) For non-Federal permittees, if the NWP activity might have the potential to cause effects to a historic property listed on, determined to be eligible for listing on, or potentially eligible for listing on, the National Register of Historic Places, the PCN must state which historic property might have the potential to be affected by the proposed activity or include a vicinity map indicating the location of the historic property. For NWP activities that require pre-construction notification, Federal permittees must provide documentation demonstrating compliance with section 106 of the National Historic Preservation Act;

(9) For an activity that will occur in a component of the National Wild and Scenic River System, or in a river officially designated by Congress as a "study river" for possible inclusion in the system while the river is in an official study status, the PCN must identify the Wild and Scenic River or the "study river" (see general condition 16); and

(10) For an activity that requires permission from the Corps pursuant to 33 U.S.C. 408 because it will alter or temporarily or permanently occupy or use a U.S. Army Corps of Engineers federally authorized civil works project, the pre-construction notification must include a statement confirming that the project proponent has submitted a written request for section 408 permission from the Corps office having jurisdiction over that USACE project.

(c) Form of Pre-Construction Notification: The standard individual permit application form (Form ENG 4345) may be used, but the completed application form must clearly indicate that it is an NWP PCN and must include all of the applicable information required in paragraphs (b)(1) through (10) of this general condition. A letter containing the required information may also be used. Applicants may provide electronic files of PCNs and supporting materials if the district engineer has established tools and procedures for electronic submittals.

(d) Agency Coordination:

(1) The district engineer will consider any comments from Federal and state agencies concerning the proposed activity's compliance with the terms and conditions of the NWPs and the need for mitigation to reduce the activity's adverse environmental effects so that they are no more than minimal.

(2) Agency coordination is required for: (i) All NWP activities that require pre-construction notification and result in the loss of greater than 1/2-acre of waters of the United States; (ii) NWP 21, 29, 39, 40, 42, 43, 44, 50, 51, and 52 activities that require pre-construction notification and will result in the loss of greater than 300 linear feet of stream bed; (iii) NWP 13

activities in excess of 500 linear feet, fills greater than one cubic yard per running foot, or involve discharges of dredged or fill material into special aquatic sites; and (iv) NWP 54 activities in excess of 500 linear feet, or that extend into the waterbody more than 30 feet from the mean low water line in tidal waters or the ordinary high water mark in the Great Lakes.

(3) When agency coordination is required, the district engineer will immediately provide (e.g., via email, facsimile transmission, overnight mail, or other expeditious manner) a copy of the complete PCN to the appropriate Federal or state offices (FWS, state natural resource or water quality agency, EPA, and, if appropriate, the NMFS). With the exception of NWP 37, these agencies will have 10 calendar days from the date the material is transmitted to notify the district engineer via telephone, facsimile transmission, or email that they intend to provide substantive, site-specific comments. The comments must explain why the agency believes the adverse environmental effects will be more than minimal. If so contacted by an agency, the district engineer will wait an additional 15 calendar days before making a decision on the pre-construction notification. The district fully consider agency comments received within the specified time frame concerning the proposed activity's compliance with the terms and conditions of the NWPs, including the need for mitigation to ensure the net adverse environmental effects of the proposed activity are no more than minimal. The district engineer will provide no response to the resource agency, except as provided below. The district engineer will indicate in the administrative record associated with each pre-construction notification that the resource agencies' concerns were considered. For NWP 37, the emergency watershed protection and rehabilitation activity may proceed immediately in cases where there is an unacceptable hazard to life or a significant loss of property or economic hardship will occur. The district engineer will consider any comments received to decide whether the NWP 37 authorization should be modified, suspended, or revoked in accordance with the procedures at 33 CFR 330.5.

(4) In cases of where the prospective permittee is not a Federal agency, the district engineer will provide a response to NMFS within 30 calendar days of receipt of any Essential Fish Habitat conservation recommendations, as required by section 305(b)(4)(B) of the Magnuson-Stevens Fishery Conservation and Management Act.

5) Applicants are encouraged to provide the Corps with either electronic files or multiple copies of pre- construction notifications to expedite agency coordination.

Further Information

1. District Engineers have authority to determine if an activity complies with the terms and conditions of an NWP.
2. NWPs do not obviate the need to obtain other federal, state, or local permits, approvals, or authorizations required by law.
3. NWPs do not grant any property rights or exclusive privileges.
4. NWPs do not authorize any injury to the property or rights of others.
5. NWPs do not authorize interference with any existing or proposed Federal project (see general condition 31).

**2017 NATIONWIDE PERMITS
REGIONAL CONDITIONS
OMAHA DISTRICT
STATE OF NORTH DAKOTA**

The following Nationwide Permit Regional Conditions will be used in the State of North Dakota. Regional conditions are placed on Nationwide Permits to ensure projects result in no more than minimal adverse impacts to the aquatic environment and to address local resource concerns.

1. **Wetlands Classified as Peatlands – Revoked for use**

All Nationwide Permits, with the exception of 3, 5, 20, 32, 38 and 45, are revoked for use in peatlands. Peatlands are permanently or seasonally saturated and inundated wetlands where conditions inhibit organic matter decomposition and allow for the accumulation of peat. Under cool, anaerobic, and acidic conditions, the rate of organic matter accumulation exceeds organic decay.

2. **Wetlands Classified as Peatlands – Preconstruction Notification Requirement**

For Nationwide Permits 3, 5, 20, 32, 38 and 45 permittees must notify the Corps in accordance with General Condition 32 (Pre-Construction Notification) prior to initiating any regulated activity impacting peatlands.

3. **Waters Adjacent to Natural Springs – Preconstruction Notification Requirement**

For all Nationwide Permits permittees must notify the Corps in accordance with General Condition No. 32 (Pre-Construction Notification) for regulated activities located within 100 feet of the water source in natural spring areas. For purposes of this condition, a spring source is defined as any location where there is flow emanating from a distinct point at any time during the growing season. Springs do not include seeps and other groundwater discharge areas where there is no distinct point source.

4. **Missouri River, including Lake Sakakawea and Lake Oahe – Pre-construction Notification Requirement**

For all Nationwide Permits permittees must notify the Corps in accordance with General Condition No. 32 (Pre-Construction Notification) prior to initiating any regulated activity occurring in or under the Missouri River, including Lake Sakakawea and Lake Oahe. In addition, any activity occurring in an off channel area (marinas, bays, etc.) of any of these waterbodies, a preconstruction notification is required.

5. **Spawning Areas**

Spawning restrictions and important fish habitat areas, if applicable, can be accessed on the North Dakota Game & Fish Department's website at:

<http://gf.nd.gov/gnf/conservation/docs/spawning-restriction-exclusions.pdf>

No regulated activity within the Red River of the North shall occur between 15 April and 1 July. Spawning season restrictions do not apply to projects involving dredging or other discharges of less than 25 cubic yards of material in any jurisdictional water.

6. Counter-Sinking Culverts and Associated Riprap – All Nationwide Permits

In streams with intermittent or perennial flow and a stable stream bed, culvert stream crossings shall be installed with the culvert invert set below the natural streambed according to the table below. This regional condition does not apply in instances where the lowering of the culvert invert would allow a headcut to migrate upstream of the project into an unaffected stream reach or result in lowering the elevation of the stream reach.

Riprap inlet and outlet protection shall be placed to match the height of the culvert invert.

Culvert Type	Drainage Area	Minimum Distance Culvert Invert Shall Be Lowered Below Stream Flow Line
All culvert types	≤ 100 acres	Not required
Pipe diameter <8.0 ft	100 to 640 acres	0.5 ft
Pipe diameter <8.0 ft	>640 acres	1.0 ft
Pipe diameter ≥ 8.0 ft	All drainage sizes	1.0 ft
Box culvert	All drainage sizes	1.0 ft

REGIONAL CONDITIONS APPLICABLE TO SPECIFIC NATIONWIDE PERMITS

Nationwide Permit 7 – Outfall Structures and Associated Intake Structures and Nationwide Permit 12 – Utility Line Activities.

Intake Structures – Intake screens with a maximum mesh opening of ¼-inch must be provided, inspected annually, and maintained. Wire, Johnson-like, screens must have a maximum distance between wires of 1/8-inch. Water velocity at the intake screen shall not exceed ½-foot per second.

Pumping plant sound levels will not exceed 75 dB at 50 feet.

Intakes located in Lake Sakakawea, above river mile 1519, and on the Yellowstone River, are subject to the following conditions:

- The intakes shall be floating.
- At the beginning of the pumping season, the intake shall be placed over water with a minimum depth of 20 feet.
- If the 20-foot depth is not attainable, then the intake shall be located over the deepest water available.

- If the water depth falls below six feet, the intake shall be moved to deeper water or the maximum intake velocity shall be limited to ¼ foot per second.

Intakes located in Lake Sakakawea, below river mile 1519, and the Missouri River below Garrison Dam are subject to the following conditions:

- The intakes shall be submerged.
- At the beginning of the pumping season, the intake will be placed at least 20 vertical feet below the existing water level.
- The intake shall be elevated 2 to 4 feet off the bottom of the river or reservoir bed.
- If the 20-foot depth is not attainable, then the intake velocity shall be limited to ¼-foot per second with intake placed at the maximum practicable attainable depth.

Intakes and associated utility lines that are proposed to cross sandbars in areas designated as piping plover critical habitat are prohibited.

Utility Lines

- Any temporary open trench associated with utility lines are to be closed within 30 days of excavation. This time limit may be extended by notifying the North Dakota Regulatory Office and receiving a written response that the extension is acceptable.

Nationwide Permit 11 – Temporary Recreational Structures – Boat Docks

To ensure that the work or structure shall not cause unreasonable obstruction to the free navigation of the navigable waters, the following conditions are required:

- No boat dock shall be located on a sandbar or barren sand feature. The farthest point riverward of a dock shall not exceed a total length of 30 feet from the ordinary high watermark. Information Note: Issuance of this permit does not supersede authorization required by the North Dakota State Engineer's Office.
- Any boat dock shall be anchored to the top of the high bank.
- Any boat dock located within an excavated bay or marina that is off the main river channel may be anchored to the bay or marina bottom with spuds.

Section 10 Waters located in the State of North Dakota are:

Bois de Sioux River
James River
Missouri River
Red River of the North
Upper Des Lacs Lake
Yellowstone River

Nationwide Permit 13 – Bank Stabilization

Permittees must notify the Corps in accordance with General Condition No. 32 (Pre-Construction Notification) prior to initiating any regulated activity. The notification must also include photo evidence of erosion in the area. Prohibited materials found at

<http://www.nwo.usace.army.mil/Media/FactSheets/FactSheetArticleView/tabid/2034/Article/487696/prohibited-restricted-materials.aspx> cannot be used in waters of the United States.

Nationwide Permit 23 – Approved Categorical Exclusions

Permittees must notify the Corps in accordance with General Condition No. 32 (Pre-Construction Notification) prior to initiating any regulated activity. In addition to information required by General Condition 32 (Pre-Construction Notification), permittees must identify the approved categorical exclusion that applies and provide documentation that the project fits the categorical exclusion.

GENERAL CONDITIONS (REGIONAL ADDITIONS)

General Condition 32 Notification– Pre-construction Notification

Prospective permittees should be aware that a field aquatic resources delineation may be required for applications where notification is required in accordance with General Condition 32 (Pre-Construction Notification) and/or mitigation may be required. Specific guidelines outlining the aquatic resources delineation process in the State of North Dakota and the Corps 1987 Wetland Delineation Manual and applicable Regional supplements to the Manual can be accessed on the North Dakota Regulatory Office's website at:
<http://www.nwo.usace.army.mil/Missions/RegulatoryProgram/NorthDakota.aspx>



Construction and Environmental Disturbance Requirements

These represent the minimum requirements of the North Dakota Department of Health. They ensure that minimal environmental degradation occurs as a result of construction or related work which has the potential to affect the waters of the State of North Dakota. All projects will be designed and implemented to restrict the losses or disturbances of soil, vegetative cover, and pollutants (chemical or biological) from a site.

Soils

Prevent the erosion of exposed soil surfaces and trapping sediments being transported. Examples include, but are not restricted to, sediment dams or berms, diversion dikes, hay bales as erosion checks, riprap, mesh or burlap blankets to hold soil during construction, and immediately establishing vegetative cover on disturbed areas after construction is completed. Fragile and sensitive areas such as wetlands, riparian zones, delicate flora, or land resources will be protected against compaction, vegetation loss, and unnecessary damage.

Surface Waters

All construction which directly or indirectly impacts aquatic systems will be managed to minimize impacts. All attempts will be made to prevent the contamination of water at construction sites from fuel spillage, lubricants, and chemicals, by following safe storage and handling procedures. Stream bank and stream bed disturbances will be controlled to minimize and/or prevent silt movement, nutrient upsurges, plant dislocation, and any physical, chemical, or biological disruption. The use of pesticides or herbicides in or near these systems is forbidden without approval from this Department.

Fill Material

Any fill material placed below the high water mark must be free of top soils, decomposable materials, and persistent synthetic organic compounds (in toxic concentrations). This includes, but is not limited to, asphalt, tires, treated lumber, and construction debris. The Department may require testing of fill materials. All temporary fills must be removed. Debris and solid wastes will be removed from the site and the impacted areas restored as nearly as possible to the original condition.



REPLY TO
ATTENTION OF

DEPARTMENT OF THE ARMY
CORPS OF ENGINEERS, OMAHA DISTRICT
NORTH DAKOTA REGULATORY OFFICE
1513 SOUTH 12TH STREET
BISMARCK ND 58504-6640

January 12, 2017

North Dakota Regulatory Office

[NWO-2017-0021-BIS]

Geronimo Energy
Attn: Ms. Melissa Schmit
7650 Edinborough Way, Suite 725
Edina, Minnesota 55435

Dear Ms. Schmit:

We have reviewed your request for Department of the Army, US Army Corps of Engineers (Corps), jurisdictional determination (JD) regarding the proposed Harmony Solar ND Project near Casselton, ND. The project site is located in Sections 10, 11 & 16, Township 140 North, Range 51 West, Cass County, North Dakota.

Based on the information that you provided, we have determined that waters identified in your request are jurisdictional waters of the United States. Therefore, should the proposed project result in the placement of dredge or fill material in the identified jurisdictional waters, a Corps permit, pursuant to Section 404 of the Clean Water Act, will be required prior to construction activities.

An approved (JD) has been completed for the wetland areas identified in your request and is enclosed for your information. The JD may also be viewed at our website located at: <http://www.nwo.usace.army.mil/Missions/RegulatoryProgram/NorthDakota.aspx>. The JD will be available on the website within 30 days. You may also request copies of the supporting materials the Corps used in determining this JD. If you are not in agreement with the JD, you may request an administrative appeal under Corps regulations found at 33 CFR 331. The request for appeal (copy enclosed) must be received within 60 days from the date of this correspondence February 25, 2016. If you would like more information on the jurisdictional appeal process, contact this office. It is not necessary to submit a Request for Appeal if you do not object to the JD. The JD will be valid for a period of 5 years from the date of this letter.

This determination was conducted to identify the limits of the Corps Clean Water Act jurisdiction for the particular site identified in this request. This determination may not be valid for the wetland conservation provisions of the Food Security Act of 1985. If you or your tenants are USDA program participants, or anticipate participation in the USDA programs, you should request a certified wetland determination from the local office of the Natural Resources Conservation Service, prior to starting work.

The Omaha District, North Dakota Regulatory Branch is committed to providing quality and timely service to our customers. In an effort to improve customer service,

please take a moment to complete our Customer Service Survey found on our website at http://corpsmapu.usace.army.mil/cm_apex/f?p=regulatory_survey. If you do not have Internet access, you may call and request a paper copy of the survey that you can complete and return to us by mail or fax.

If you have any questions concerning this determination or jurisdiction, please feel free to contact Mr. Benjamin Reile of this office at (701) 255-0015, extension [2013], and reference project number **NWO-2017-0021-BIS**

Sincerely,

A handwritten signature in black ink, appearing to read "Patricia L. McQueary". The signature is fluid and cursive, with a large initial "P" and "M".

Patricia L. McQueary
Regulatory Program Manager
North Dakota

Enclosures

APPROVED JURISDICTIONAL DETERMINATION FORM
U.S. Army Corps of Engineers

This form should be completed by following the instructions provided in Section IV of the JD Form Instructional Guidebook.

SECTION I: BACKGROUND INFORMATION

A. REPORT COMPLETION DATE FOR APPROVED JURISDICTIONAL DETERMINATION (JD): January 12, 2017

B. DISTRICT OFFICE, FILE NAME, AND NUMBER: Omaha District; Geronimo Energy; Harmony Solar ND Project; NWO-2017-0021-BIS.

C. PROJECT LOCATION AND BACKGROUND INFORMATION:

State: North Dakota. County/parish/borough: Cass City: Casselton
Center coordinates of site (lat/long in degree decimal format): Lat. Long.

Site #	Latitude	Longitude	Cowardin Class	Estimated amount of aquatic resource in review area (acres)
NWO-2017-0021-BIS, Lower Branch Rush River	46.953085	-97.098964	R3	~1,000 Linear Feet

Name of nearest waterbody: Lower Branch Rush River

Name of nearest Traditional Navigable Water (TNW) into which the aquatic resource flows: Red River of the North.

Name of watershed or Hydrologic Unit Code (HUC): Souris-Red-Rainy Region - 09020204.

- Check if map/diagram of review area and/or potential jurisdictional areas is/are available upon request.
 Check if other sites (e.g., offsite mitigation sites, disposal sites, etc...) are associated with this action and are recorded on a different JD form.

D. REVIEW PERFORMED FOR SITE EVALUATION (CHECK ALL THAT APPLY):

- Office (Desk) Determination. Date: January 09, 2017
 Field Determination. Date(s):

SECTION II: SUMMARY OF FINDINGS

A. RHA SECTION 10 DETERMINATION OF JURISDICTION.

There are no "navigable waters of the U.S." within Rivers and Harbors Act (RHA) jurisdiction (as defined by 33 CFR part 329) in the review area. [Required]

- Waters subject to the ebb and flow of the tide.
 Waters are presently used, or have been used in the past, or may be susceptible for use to transport interstate or foreign commerce.
Explain:

B. CWA SECTION 404 DETERMINATION OF JURISDICTION.

There are "waters of the U.S." within Clean Water Act (CWA) jurisdiction (as defined by 33 CFR part 328) in the review area. [Required]

1. Waters of the U.S.

a. Indicate presence of waters of U.S. in review area (check all that apply):¹

- TNWs, including territorial seas
 Wetlands adjacent to TNWs
 Relatively permanent waters² (RPWs) that flow directly or indirectly into TNWs
 Non-RPWs that flow directly or indirectly into TNWs
 Wetlands directly abutting RPWs that flow directly or indirectly into TNWs
 Wetlands adjacent to but not directly abutting RPWs that flow directly or indirectly into TNWs
 Wetlands adjacent to non-RPWs that flow directly or indirectly into TNWs
 Impoundments of jurisdictional waters
 Isolated (interstate or intrastate) waters, including isolated wetland

b. Identify (estimate) size of waters of the U.S. in the review area:

Non-wetland waters: linear feet: ~1,000 lineal feet
Wetlands:

c. Limits (boundaries) of jurisdiction based on: Pick List

Elevation of established OHWM (if known):

2. Non-regulated waters/wetlands (check if applicable):³

¹ Boxes checked below shall be supported by completing the appropriate sections in Section III below.

² For purposes of this form, an RPW is defined as a tributary that is not a TNW and that typically flows year-round or has continuous flow at least "seasonally" (e.g., typically 3 months).

³ Supporting documentation is presented in Section III.F.

- Potentially jurisdictional waters and/or wetlands were assessed within the review area and determined to be not jurisdictional. Explain:

SECTION III: CWA ANALYSIS

A. TNWs AND WETLANDS ADJACENT TO TNWs

The agencies will assert jurisdiction over TNWs and wetlands adjacent to TNWs. If the aquatic resource is a TNW, complete Section III.A.1 and Section III.D.1. only; if the aquatic resource is a wetland adjacent to a TNW, complete Sections III.A.1 and 2 and Section III.D.1.; otherwise, see Section III.B below.

1. TNW

Identify TNW:

Summarize rationale supporting determination:

2. Wetland adjacent to TNW

Summarize rationale supporting conclusion that wetland is "adjacent":

B. CHARACTERISTICS OF TRIBUTARY (THAT IS NOT A TNW) AND ITS ADJACENT WETLANDS (IF ANY):

This section summarizes information regarding characteristics of the tributary and its adjacent wetlands, if any, and it helps determine whether or not the standards for jurisdiction established under *Rapanos* have been met.

The agencies will assert jurisdiction over non-navigable tributaries of TNWs where the tributaries are "relatively permanent waters" (RPWs), i.e. tributaries that typically flow year-round or have continuous flow at least seasonally (e.g., typically 3 months). A wetland that directly abuts an RPW is also jurisdictional. If the aquatic resource is not a TNW, but has year-round (perennial) flow, skip to Section III.D.2. If the aquatic resource is a wetland directly abutting a tributary with perennial flow, skip to Section III.D.4.

A wetland that is adjacent to but that does not directly abut an RPW requires a significant nexus evaluation. Corps districts and EPA regions will include in the record any available information that documents the existence of a significant nexus between a relatively permanent tributary that is not perennial (and its adjacent wetlands if any) and a traditional navigable water, even though a significant nexus finding is not required as a matter of law.

If the waterbody⁴ is not an RPW, or a wetland directly abutting an RPW, a JD will require additional data to determine if the waterbody has a significant nexus with a TNW. If the tributary has adjacent wetlands, the significant nexus evaluation must consider the tributary in combination with all of its adjacent wetlands. This significant nexus evaluation that combines, for analytical purposes, the tributary and all of its adjacent wetlands is used whether the review area identified in the JD request is the tributary, or its adjacent wetlands, or both. If the JD covers a tributary with adjacent wetlands, complete Section III.B.1 for the tributary, Section III.B.2 for any onsite wetlands, and Section III.B.3 for all wetlands adjacent to that tributary, both onsite and offsite. The determination whether a significant nexus exists is determined in Section III.C below.

1. Characteristics of non-TNWs that flow directly or indirectly into TNW

(i) General Area Conditions:

Watershed size: acres

Drainage area:

Average annual rainfall: inches

Average annual snowfall: inches

(ii) Physical Characteristics:

(a) Relationship with TNW:

Tributary flows directly into TNW.

Tributary flows through before entering TNW.

Project waters are from TNW.

Project waters are miles from RPW.

⁴ Note that the Instructional Guidebook contains additional information regarding swales, ditches, washes, and erosional features generally and in the arid West.

Project waters are aerial (straight) miles from TNW.
 Project waters are aerial (straight) miles from RPW.
 Project waters cross or serve as state boundaries. Explain:
 Identify flow route to TNW⁵:
 Tributary stream order, if known:

(b) General Tributary Characteristics (check all that apply):

Tributary is: Natural
 Artificial (man-made). Explain:
 Manipulated (man-altered). Explain

Tributary properties with respect to top of bank (estimate):

Average width: feet
 Average depth: feet
 Average side slopes:

Primary tributary substrate composition (check all that apply):

Silts Sands Concrete
 Cobbles Gravel Muck
 Bedrock Vegetation. Type/% cover:
 Other. Explain:

Tributary condition/stability [e.g., highly eroding, sloughing banks]. Explain:

Presence of run/riffle/pool complexes. Explain:

Tributary geometry:

Tributary gradient (approximate average slope): %

(c) Flow:

Tributary provides for:

Estimate average number of flow events in review area/year:

Describe flow regime:

Other information on duration and volume:

Surface flow is: Characteristics:

Subsurface flow: Explain findings: NA.

Dye (or other) test performed: NA.

Tributary has (check all that apply):

Bed and banks
 OHWM⁶ (check all indicators that apply):
 clear, natural line impressed on the bank the presence of litter and debris
 changes in the character of soil destruction of terrestrial vegetation
 shelving the presence of wrack line
 vegetation matted down, bent, or absent sediment sorting
 leaf litter disturbed or washed away scour
 sediment deposition multiple observed or predicted flow events
 water staining abrupt change in plant community
 other (list):
 Discontinuous OHWM.⁷ Explain:

If factors other than the OHWM were used to determine lateral extent of CWA jurisdiction (check all that apply):

High Tide Line indicated by: Mean High Water Mark indicated by:
 oil or scum line along shore objects survey to available datum;
 fine shell or debris deposits (foreshore) physical markings;
 physical markings/characteristics vegetation lines/changes in vegetation types.
 tidal gauges
 other (list):

⁵ Flow route can be described by identifying, e.g., tributary a, which flows through the review area, to flow into tributary b, which then flows into TNW.

⁶A natural or man-made discontinuity in the OHWM does not necessarily sever jurisdiction (e.g., where the stream temporarily flows underground, or where the OHWM has been removed by development or agricultural practices). Where there is a break in the OHWM that is unrelated to the waterbody's flow regime (e.g., flow over a rock outcrop or through a culvert), the agencies will look for indicators of flow above and below the break.

⁷Ibid.

(iii) Chemical Characteristics:

Characterize tributary (e.g., water color is clear, discolored, oily film; water quality; general watershed characteristics, etc.).
Explain:
Identify specific pollutants, if known:.

(iv) Biological Characteristics. Channel supports (check all that apply):

- Riparian corridor. Characteristics (type, average width): NA
- Wetland fringe. Characteristics:
- Habitat for: NA
 - Federally Listed species. Explain findings:
 - Fish/spawn areas. Explain findings:
 - Other environmentally-sensitive species. Explain findings:
 - Aquatic/wildlife diversity. Explain findings:

2. Characteristics of wetlands adjacent to non-TNW that flow directly or indirectly into TNW

(i) Physical Characteristics:

(a) General Wetland Characteristics:

Properties:
Wetland size:
Wetland type. Explain:
Wetland quality. Explain:
Project wetlands cross or serve as state boundaries. Explain:.

(b) General Flow Relationship with Non-TNW:

Flow is: Explain:

Surface flow is:
Characteristics:

Subsurface flow: Explain findings:
 Dye (or other) test performed:

(c) Wetland Adjacency Determination with Non-TNW:

- Directly abutting
- Not directly abutting
 - Discrete wetland hydrologic connection. Explain:
 - Ecological connection. Explain:
 - Separated by berm/barrier. Explain:

(d) Proximity (Relationship) to TNW

Project wetlands are miles from TNW.
Project waters are aerial (straight) miles from TNW.
Flow is from:
Estimate approximate location of wetland as within the floodplain.

(ii) Chemical Characteristics:

Characterize wetland system (e.g., water color is clear, brown, oil film on surface; water quality; general watershed characteristics; etc.). Explain:
Identify specific pollutants, if known:

(iii) Biological Characteristics. Wetland supports (check all that apply):

- Riparian buffer. Characteristics (type, average width):
- Vegetation type/percent cover. Explain:
- Habitat for:
 - Federally Listed species. Explain findings:
 - Fish/spawn areas. Explain findings:
 - Other environmentally-sensitive species. Explain findings:
 - Aquatic/wildlife diversity. Explain findings:

3. Characteristics of all wetlands adjacent to the tributary (if any)

All wetland(s) being considered in the cumulative analysis:
Approximately () acres in total are being considered in the cumulative analysis.

For each wetland, specify the following:

Directly abuts? (Y/N)

Size (in acres)

Directly abuts? (Y/N)

Size (in acres)

Summarize overall biological, chemical and physical functions being performed:

C. SIGNIFICANT NEXUS DETERMINATION

A significant nexus analysis will assess the flow characteristics and functions of the tributary itself and the functions performed by any wetlands adjacent to the tributary to determine if they significantly affect the chemical, physical, and biological integrity of a TNW. For each of the following situations, a significant nexus exists if the tributary, in combination with all of its adjacent wetlands, has more than a speculative or insubstantial effect on the chemical, physical and/or biological integrity of a TNW. Considerations when evaluating significant nexus include, but are not limited to the volume, duration, and frequency of the flow of water in the tributary and its proximity to a TNW, and the functions performed by the tributary and all its adjacent wetlands. It is not appropriate to determine significant nexus based solely on any specific threshold of distance (e.g. between a tributary and its adjacent wetland or between a tributary and the TNW). Similarly, the fact an adjacent wetland lies within or outside of a floodplain is not solely determinative of significant nexus.

Draw connections between the features documented and the effects on the TNW, as identified in the *Rapanos* Guidance and discussed in the Instructional Guidebook. Factors to consider include, for example:

- Does the tributary, in combination with its adjacent wetlands (if any), have the capacity to carry pollutants or flood waters to TNWs, or to reduce the amount of pollutants or flood waters reaching a TNW?
- Does the tributary, in combination with its adjacent wetlands (if any), provide habitat and lifecycle support functions for fish and other species, such as feeding, nesting, spawning, or rearing young for species that are present in the TNW?
- Does the tributary, in combination with its adjacent wetlands (if any), have the capacity to transfer nutrients and organic carbon that support downstream foodwebs?
- Does the tributary, in combination with its adjacent wetlands (if any), have other relationships to the physical, chemical, or biological integrity of the TNW?

Note: the above list of considerations is not inclusive and other functions observed or known to occur should be documented below:

1. **Significant nexus findings for non-RPW that has no adjacent wetlands and flows directly or indirectly into TNWs.** Explain findings of presence or absence of significant nexus below, based on the tributary itself, then go to Section III.D:
2. **Significant nexus findings for non-RPW and its adjacent wetlands, where the non-RPW flows directly or indirectly into TNWs.** Explain findings of presence or absence of significant nexus below, based on the tributary in combination with all of its adjacent wetlands, then go to Section III.D:
3. **Significant nexus findings for wetlands adjacent to an RPW but that do not directly abut the RPW.** Explain findings of presence or absence of significant nexus below, based on the tributary in combination with all of its adjacent wetlands, then go to Section III.D:

D. DETERMINATIONS OF JURISDICTIONAL FINDINGS. THE SUBJECT WATERS/WETLANDS ARE (CHECK ALL THAT APPLY):

1. **TNWs and Adjacent Wetlands.** Check all that apply and provide size estimates in review area:
 TNWs: linear feet width (ft), Or, acres.
 Wetlands adjacent to TNWs: acres.
2. **RPWs that flow directly or indirectly into TNWs.**
 Tributaries of TNWs where tributaries typically flow year-round are jurisdictional. Provide data and rationale indicating that tributary is perennial: South Branch Rush River (project location), a perennial stream flows Northeast into the Red River of the North, a TNW. The project location is approximately 10-miles from the TNW. This waterway does flow year-round.
 Tributaries of TNW where tributaries have continuous flow "seasonally" (e.g., typically three months each year) are jurisdictional. Data supporting this conclusion is provided at Section III.B. Provide rationale indicating that tributary flows seasonally:

Provide estimates for jurisdictional waters in the review area (check all that apply):

- Tributary waters: **1,000** linear feet. width (ft).
 - Other non-wetland waters: acres.
- Identify type(s) of waters:

3. Non-RPWs⁸ that flow directly or indirectly into TNWs.

- Waterbody that is not a TNW or an RPW, but flows directly or indirectly into a TNW, and it has a significant nexus with a TNW is jurisdictional. Data supporting this conclusion is provided at Section III.C.

Provide estimates for jurisdictional waters within the review area (check all that apply):

- Tributary waters: linear feet width (ft).
 - Other non-wetland waters: acres.
- Identify type(s) of waters:

4. Wetlands directly abutting an RPW that flow directly or indirectly into TNWs.

- Wetlands directly abut RPW and thus are jurisdictional as adjacent wetlands.
 - Wetlands directly abutting an RPW where tributaries typically flow year-round. Provide data and rationale indicating that tributary is perennial in Section III.D.2, above. Provide rationale indicating that wetland is directly abutting an RPW:
 - Wetlands directly abutting an RPW where tributaries typically flow "seasonally." Provide data indicating that tributary is seasonal in Section III.B and rationale in Section III.D.2, above. Provide rationale indicating that wetland is directly abutting an RPW:

Provide acreage estimates for jurisdictional wetlands in the review area:

5. Wetlands adjacent to but not directly abutting an RPW that flow directly or indirectly into TNWs.

- Wetlands that do not directly abut an RPW, but when considered in combination with the tributary to which they are adjacent and with similarly situated adjacent wetlands, have a significant nexus with a TNW are jurisdictional. Data supporting this conclusion is provided at Section III.C.

Provide acreage estimates for jurisdictional wetlands in the review area: acres.

6. Wetlands adjacent to non-RPWs that flow directly or indirectly into TNWs.

- Wetlands adjacent to such waters, and have when considered in combination with the tributary to which they are adjacent and with similarly situated adjacent wetlands, have a significant nexus with a TNW are jurisdictional. Data supporting this conclusion is provided at Section III.C.

Provide estimates for jurisdictional wetlands in the review area:

7. Impoundments of jurisdictional waters.⁹

As a general rule, the impoundment of a jurisdictional tributary remains jurisdictional.

- Demonstrate that impoundment was created from "waters of the U.S.," or
- Demonstrate that water meets the criteria for one of the categories presented above (1-6), or
- Demonstrate that water is isolated with a nexus to commerce (see E below).

E. ISOLATED [INTERSTATE OR INTRA-STATE] WATERS, INCLUDING ISOLATED WETLANDS, THE USE, DEGRADATION OR DESTRUCTION OF WHICH COULD AFFECT INTERSTATE COMMERCE, INCLUDING ANY SUCH WATERS (CHECK ALL THAT APPLY):¹⁰

- which are or could be used by interstate or foreign travelers for recreational or other purposes.
- from which fish or shellfish are or could be taken and sold in interstate or foreign commerce.
- which are or could be used for industrial purposes by industries in interstate commerce.
- Interstate isolated waters. Explain:
- Other factors. Explain:

Identify water body and summarize rationale supporting determination:

⁸See Footnote # 3.

⁹ To complete the analysis refer to the key in Section III.D.6 of the Instructional Guidebook.

¹⁰ Prior to asserting or declining CWA jurisdiction based solely on this category, Corps Districts will elevate the action to Corps and EPA HQ for review consistent with the process described in the Corps/EPA Memorandum Regarding CWA Act Jurisdiction Following Rapanos.

Provide estimates for jurisdictional waters in the review area (check all that apply):

- Tributary waters: linear feet width (ft).
- Other non-wetland waters: acres.
Identify type(s) of waters: .
- Wetlands: acres.

F. NON-JURISDICTIONAL WATERS, INCLUDING WETLANDS (CHECK ALL THAT APPLY):

- If potential wetlands were assessed within the review area, these areas did not meet the criteria in the 1987 Corps of Engineers Wetland Delineation Manual and/or appropriate Regional Supplements.
- Review area included isolated waters with no substantial nexus to interstate (or foreign) commerce.
 - Prior to the Jan 2001 Supreme Court decision in "SWANCC," the review area would have been regulated based solely on the "Migratory Bird Rule" (MBR).
- Waters do not meet the "Significant Nexus" standard, where such a finding is required for jurisdiction. Explain: .
- Other: (explain, if not covered above):

Provide acreage estimates for non-jurisdictional waters in the review area, where the sole potential basis of jurisdiction is the MBR factors (i.e., presence of migratory birds, presence of endangered species, use of water for irrigated agriculture), using best professional judgment (check all that apply):

- Non-wetland waters (i.e., rivers, streams): linear feet width (ft).
- Lakes/ponds: acres.
- Other non-wetland waters: acres. List type of aquatic resource: .
- Wetlands:

Provide acreage estimates for non-jurisdictional waters in the review area that do not meet the "Significant Nexus" standard, where such a finding is required for jurisdiction (check all that apply):

- Non-wetland waters (i.e., rivers, streams): linear feet, width (ft).
- Lakes/ponds: acres.
- Other non-wetland waters: acres. List type of aquatic resource: .
- Wetlands:

SECTION IV: DATA SOURCES.

A. SUPPORTING DATA. Data reviewed for JD (check all that apply - checked items shall be included in case file and, where checked and requested, appropriately reference sources below):

- Maps, plans, plots or plat submitted by or on behalf of the applicant/consultant: **Geronimo Energy**
- Data sheets prepared/submitted by or on behalf of the applicant/consultant.
 - Office concurs with data sheets/delineation report.
 - Office does not concur with data sheets/delineation report.
- Data sheets prepared by the Corps:
- Corps navigable waters' study:
- U.S. Geological Survey Hydrologic Atlas: **09020204.**
 - USGS NHD data.
 - USGS 8 and 12 digit HUC maps.
- U.S. Geological Survey map(s). Cite scale & quad name: **ND-Mapleton - 1:24,000.**
- USDA Natural Resources Conservation Service Soil Survey. Citation:
- National wetlands inventory map(s). Cite name:
- State/Local wetland inventory map(s): .
- FEMA/FIRM maps:
- 100-year Floodplain Elevation is: (National Geodetic Vertical Datum of 1929)
- Photographs: Aerial (Name & Date): **Google Earth Pro.**
or Other (Name & Date):
- Previous determination(s). File no. and date of response letter: .
- Applicable/supporting case law: .
- Applicable/supporting scientific literature: .
- Other information (please specify):

B. ADDITIONAL COMMENTS TO SUPPORT JD:

NOTIFICATION OF ADMINISTRATIVE APPEAL OPTIONS AND PROCESS AND REQUEST FOR APPEAL

Applicant: Harmony Solar ND, LLC		File Number: 2017-0021-BIS	Date: 1/12/2017
Attached is:			See Section below
	INITIAL PROFFERED PERMIT (Standard Permit or Letter of permission)		A
	PROFFERED PERMIT (Standard Permit or Letter of permission)		B
	PERMIT DENIAL		C
X	APPROVED JURISDICTIONAL DETERMINATION		D
	PRELIMINARY JURISDICTIONAL DETERMINATION		E

SECTION I - The following identifies your rights and options regarding an administrative appeal of the above decision. Additional information may be found in Corps regulations at 33 CFR Part 331, or at <http://www.usace.army.mil/Missions/CivilWorks/RegulatoryProgramandPermits/FederalRegulation.aspx>

A: INITIAL PROFFERED PERMIT: You may accept or object to the permit.

- **ACCEPT:** If you received a Standard Permit, you may sign the permit document and return it to the district engineer for final authorization. If you received a Letter of Permission (LOP), you may accept the LOP and your work is authorized. Your signature on the Standard Permit or acceptance of the LOP means that you accept the permit in its entirety, and waive all rights to appeal the permit, including its terms and conditions, and approved jurisdictional determinations associated with the permit.
- **OBJECT:** If you object to the permit (Standard or LOP) because of certain terms and conditions therein, you may request that the permit be modified accordingly. You must complete Section II of this form and return the form to the district engineer. Your objections must be received by the district engineer within 60 days of the date of this notice, or you will forfeit your right to appeal the permit in the future. Upon receipt of your letter, the district engineer will evaluate your objections and may: (a) modify the permit to address all of your concerns, (b) modify the permit to address some of your objections, or (c) not modify the permit having determined that the permit should be issued as previously written. After evaluating your objections, the district engineer will send you a proffered permit for your reconsideration, as indicated in Section B below.

B: PROFFERED PERMIT: You may accept or appeal the permit

- **ACCEPT:** If you received a Standard Permit, you may sign the permit document and return it to the district engineer for final authorization. If you received a Letter of Permission (LOP), you may accept the LOP and your work is authorized. Your signature on the Standard Permit or acceptance of the LOP means that you accept the permit in its entirety, and waive all rights to appeal the permit, including its terms and conditions, and approved jurisdictional determinations associated with the permit.
- **APPEAL:** If you choose to decline the proffered permit (Standard or LOP) because of certain terms and conditions therein, you may appeal the declined permit under the Corps of Engineers Administrative Appeal Process by completing Section II of this form and sending the form to the division engineer. This form must be received by the division engineer within 60 days of the date of this notice.

C: PERMIT DENIAL: You may appeal the denial of a permit under the Corps of Engineers Administrative Appeal Process by completing Section II of this form and sending the form to the division engineer. This form must be received by the division engineer within 60 days of the date of this notice.

D: APPROVED JURISDICTIONAL DETERMINATION: You may accept or appeal the approved JD or provide new information.

- **ACCEPT:** You do not need to notify the Corps to accept an approved JD. Failure to notify the Corps within 60 days of the date of this notice, means that you accept the approved JD in its entirety, and waive all rights to appeal the approved JD.
- **APPEAL:** If you disagree with the approved JD, you may appeal the approved JD under the Corps of Engineers Administrative Appeal Process by completing Section II of this form and sending the form to the division engineer. This form must be received by the division engineer within 60 days of the date of this notice.

E: PRELIMINARY JURISDICTIONAL DETERMINATION: You do not need to respond to the Corps regarding the preliminary JD. The Preliminary JD is not appealable. If you wish, you may request an approved JD (which may be appealed), by contacting the Corps district for further instruction. Also you may provide new information for further consideration by the Corps to reevaluate the JD.

SECTION II - REQUEST FOR APPEAL or OBJECTIONS TO AN INITIAL PROFFERED PERMIT

REASONS FOR APPEAL OR OBJECTIONS: (Describe your reasons for appealing the decision or your objections to an initial proffered permit in clear concise statements. You may attach additional information to this form to clarify where your reasons or objections are addressed in the administrative record.)

ADDITIONAL INFORMATION: The appeal is limited to a review of the administrative record, the Corps memorandum for the record of the appeal conference or meeting, and any supplemental information that the review officer has determined is needed to clarify the administrative record. Neither the appellant nor the Corps may add new information or analyses to the record. However, you may provide additional information to clarify the location of information that is already in the administrative record.

POINT OF CONTACT FOR QUESTIONS OR INFORMATION:

If you have questions regarding this decision and/or the appeal process you may contact:

US Army Corps of Engineers, Omaha District
North Dakota Regulatory Office
Attn: Ms. Patricia L. McQueary
1513 South 12th Street
Bismarck, North Dakota 58504

If you only have questions regarding the appeal process you may also contact:

US Army Corps of Engineers, Northwestern Division
Attn: Regulatory Appeals Review Officer
P.O. Box 2870
Portland, OR 97208-2870 Telephone (503) 808-3888

RIGHT OF ENTRY: Your signature below grants the right of entry to Corps of Engineers personnel, and any government consultants, to conduct investigations of the project site during the course of the appeal process. You will be provided a 15 day notice of any site investigation, and will have the opportunity to participate in all site investigations.

Signature of appellant or agent.

Date:

Telephone number:

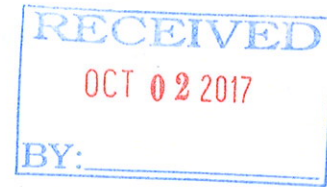

September 25, 2017

Scott Larson
U.S. Fish and Wildlife Service
3425 Miriam Avenue
Bismarck, ND 58501

RE: Requesting Comments on Harmony Solar in Cass County, North Dakota

Dear Scott Larson,

Harmony Solar ND, LLC (“Harmony”), a wholly owned subsidiary of Geronimo Energy, LLC, is gathering information and requesting agency comments for a proposed utility scale solar energy project in Cass County, North Dakota.

Harmony will be submitting an Application for a Certificate of Corridor Compatibility to the North Dakota Public Service Commission (“PSC”).

The planned output for the Project is up to 200 megawatts of nameplate solar energy capacity. The Project’s permanent facilities will include:

- Solar modules, inverters and racking;
- Fencing;
- Access roads as required;
- Operations and maintenance (O&M) building;
- Substation facility;
- On-site underground electrical collection lines; and
- Up to two weather stations (up to 20 feet tall).

Harmony will interconnect to the Bison substation located in Section 11 of Township 140, Range 51 via a 345 kV transmission line. The transmission line route has not yet been determined, however it will be under one mile in length and therefore will not be reviewed by the PSC.

The racking layout, access roads and electrical connections have not been finalized at this time. Table 1 provides the sections of land Harmony is evaluating for siting the solar energy project.

Table 1: Sections within the Harmony Project Boundary

State	County	Civil Township Name	Township	Range	Sections
ND	Cass	Harmony	140 N	51 W	10, 11, 16



To facilitate your review, we have enclosed a map of Harmony's location and the associated project boundary.

Harmony will seek a Certificate of Site Compatibility from the North Dakota Public Service Commission (PSC) pursuant to Chapter 49-22 of the North Dakota Century Code and Article 69-06 of the North Dakota Administrative Code. Construction is anticipated to begin as early as spring of 2019 with intended completion by the end of 2020.

The purpose of this letter is to inform your organization of the proposed Project, seek your input regarding any permits and approvals that may be required, and identify interests your organization may have in the Project site or associated study area. Any written agency comments provided in response to this letter will be incorporated into the PSC's review process.

If you require further information or have questions regarding this matter, please contact me at 952-988-9000 or at melissa@geronimoenergy.com.

Sincerely,

Melissa Schmit
Senior Permitting Specialist

U.S. FISH AND WILDLIFE SERVICE
ND Ecological Services Field Office

Enclosure:
Harmony Location Map

This constitutes a report of the Department of the Interior prepared in accordance with the Fish and Wildlife Coordination Act (16 U.S.C. 661 et seq). We have reviewed and have NO OBJECTION to this project.

10/31/2017
Date

North Dakota State Supervisor



October 11, 2017

Ms. Melissa Schmit
Senior Permitting Specialist
Geronimo Energy, LLC
7650 Edinborough Way, Ste 725
Edina, MN 55435

Re: Harmony Solar, Cass County, ND

Dear Ms. Schmit:

This department has reviewed the information concerning the above-referenced project submitted under date of September 25, 2017, with respect to possible environmental impacts.

This department believes that environmental impacts from the proposed construction will be minor and can be controlled by proper construction methods. With respect to construction, we have the following comments:

1. All necessary measures must be taken to minimize fugitive dust emissions created during construction activities. Any complaints that may arise are to be dealt with in an efficient and effective manner.
2. Care is to be taken during construction activity near any water of the state to minimize adverse effects on a water body. This includes minimal disturbance of stream beds and banks to prevent excess siltation, and the replacement and revegetation of any disturbed area as soon as possible after work has been completed. Caution must also be taken to prevent spills of oil and grease that may reach the receiving water from equipment maintenance, and/or the handling of fuels on the site. Guidelines for minimizing degradation to waterways during construction are attached.
3. Projects disturbing one or more acres are required to have a permit to discharge storm water runoff until the site is stabilized by the reestablishment of vegetation or other permanent cover. Further information on the storm water permit may be obtained from the Department's website or by calling the Division of Water Quality (701-328-5210). Also, cities may impose additional requirements and/or specific best management practices for construction affecting their storm drainage system. Check with the local officials to be sure any local storm water management considerations are addressed.

Ms. Melissa Schmit

2.

October 11, 2017

The department owns no land in or adjacent to the proposed improvements, nor does it have any projects scheduled in the area. In addition, we believe the proposed activities are consistent with the State Implementation Plan for the Control of Air Pollution for the State of North Dakota.

These comments are based on the information provided about the project in the above-referenced submittal. The U.S. Army Corps of Engineers may require a water quality certification from this department for the project if the project is subject to their Section 404 permitting process. Any additional information which may be required by the U.S. Army Corps of Engineers under the process will be considered by this department in our determination regarding the issuance of such a certification.

If you have any questions regarding our comments, please feel free to contact this office.

Sincerely,

A handwritten signature in blue ink, appearing to read "L. David Glatt".

L. David Glatt, P.E., Chief
Environmental Health Section

LDG:cc
Attach.



Construction and Environmental Disturbance Requirements

These represent the minimum requirements of the North Dakota Department of Health. They ensure that minimal environmental degradation occurs as a result of construction or related work which has the potential to affect the waters of the State of North Dakota. All projects will be designed and implemented to restrict the losses or disturbances of soil, vegetative cover, and pollutants (chemical or biological) from a site.

Soils

Prevent the erosion of exposed soil surfaces and trapping sediments being transported. Examples include, but are not restricted to, sediment dams or berms, diversion dikes, hay bales as erosion checks, riprap, mesh or burlap blankets to hold soil during construction, and immediately establishing vegetative cover on disturbed areas after construction is completed. Fragile and sensitive areas such as wetlands, riparian zones, delicate flora, or land resources will be protected against compaction, vegetation loss, and unnecessary damage.

Surface Waters

All construction which directly or indirectly impacts aquatic systems will be managed to minimize impacts. All attempts will be made to prevent the contamination of water at construction sites from fuel spillage, lubricants, and chemicals, by following safe storage and handling procedures. Stream bank and stream bed disturbances will be controlled to minimize and/or prevent silt movement, nutrient upsurges, plant dislocation, and any physical, chemical, or biological disruption. The use of pesticides or herbicides in or near these systems is forbidden without approval from this Department.

Fill Material

Any fill material placed below the high water mark must be free of top soils, decomposable materials, and persistent synthetic organic compounds (in toxic concentrations). This includes, but is not limited to, asphalt, tires, treated lumber, and construction debris. The Department may require testing of fill materials. All temporary fills must be removed. Debris and solid wastes will be removed from the site and the impacted areas restored as nearly as possible to the original condition.



North Dakota Department of Transportation

Thomas K. Sorel
Director

Doug Burgum
Governor

October 17, 2017

Melissa Schmit
Senior Permitting Specialist
Harmony Solar
7650 Edenborough Way, Suite 725
Edina, MN 55435

PROPOSED UTILITY SCALE SOLAR ENERGY PROJECT, CASS COUNTY, NORTH
DAKOTA

We have reviewed your September 25, 2017, letter.

This project should have no adverse effect on the North Dakota Department of Transportation highways.

However, if because of this project any work needs to be done on highway right of way, appropriate permits and risk management documents will need to be obtained from the Department of Transportation District Engineer, Robert Walton at 701-239-8903.

A handwritten signature in black ink that reads "Robert Fode".

ROBERT A. FODE, P.E., DIRECTOR – OFFICE OF PROJECT DEVELOPMENT

57/raf/js

c: Robert Walton, Fargo District Engineer



Jack Dalrymple, Governor
Mark A. Zimmerman, Director
1600 East Century Avenue, Suite 3
Bismarck, ND 58503-0649
Phone 701-328-5357
Fax 701-328-5363
E-mail parkrec@nd.gov
www.parkrec.nd.gov

August 29, 2016

Melissa Schmit
Geronimo Energy
7650 Edinborough Way, Suite 725
Edina, MN 55435

Re: Solar Development in Cass County

Dear Ms. Schmit,

The North Dakota Parks and Recreation Department has reviewed the above referenced proposed Solar Development project in Cass County.

Our agency scope of authority and expertise covers recreation and biological resources (in particular rare plants and ecological communities). The project as defined does not affect state park lands that we manage or Land and Water Conservation Fund recreation projects that we coordinate.

The North Dakota Natural Heritage biological conservation database has been reviewed to determine if any plant or animal species of concern or other significant ecological communities are known to occur within an approximate one-mile radius of the project area. Based on this review, there are no documented occurrences in our database within or adjacent to project area. Because this information is not based on a comprehensive inventory, there may be species of concern or otherwise significant ecological communities in the area that are not represented in the database. The lack of data for any project area cannot be construed to mean that no significant features are present. The absence of data may indicate that the project area has not been surveyed, rather than confirm that the area lacks natural heritage resources.

The Department recommends that the project be accomplished with minimal impacts and that all efforts be made to ensure that critical habitats not be disturbed in the project area to help secure rare species conservation in North Dakota. Regarding any reclamation efforts, we recommend that any impacted areas be revegetated with species native to the project area.

We appreciate your commitment to rare plant, animal and ecological community conservation, management and inter-agency cooperation to date. For additional information please contact me at (701-328-5370 or kgduttonhefner@nd.gov). Thank you for the opportunity to comment on this proposed project.

Sincerely,

A handwritten signature in blue ink, appearing to read "Kathy Duttonhefner", with a long horizontal flourish extending to the right.

Kathy Duttonhefner, Coordinator
Natural Resources Division

R.USNDNHI*2016_2225KD8/29/16DL8.29.2016

• • • • •
Play in our backyard!

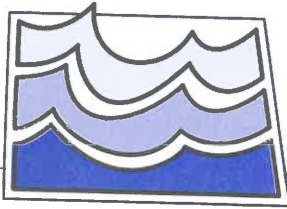

North Dakota State Water Commission

900 EAST BOULEVARD AVENUE, DEPT 770 • BISMARCK, NORTH DAKOTA 58505-0850
(701) 328-2750 • TTY 1-800-366-6888 or 711 • FAX (701) 328-3696 • <http://swc.nd.gov>

October 23, 2017

Melissa Schmit
Harmony Solar
7650 Edinborough Way, STE 725
Edina, MN 55435

Dear Ms. Schmit:

This is in response to your request for a review of the environmental impacts associated with the utility scale solar energy project in Cass County, ND.

The proposed project has been reviewed by State Water Commission staff, and the following comments are provided:

- No permits are required relative to the National Flood Insurance Program (NFIP) based on the current effective FIRM and state minimum standards.
- Initial review indicates the project does not require a conditional or temporary permit for water appropriation. However, if surface water or groundwater will be diverted for construction of the project, a water permit will be required per North Dakota Century Code (NDCC) § 61-04-02. Please consult with the Water Appropriations Division of the Office of the State Engineer (OSE) if you have any questions regarding this comment at 701-328-2754 or waterpermits@nd.gov.
- The OSE Engineering and Permitting Section reviewed the project location and determined that the project will be constructed near or in the vicinity of surface water resources. The OSE requests to be notified regarding the proposed project's impacts, if any, to water resources (i.e. streams or rivers), drains, and wetlands (i.e. ponds, sloughs, lakes, or any series thereof) as any alterations, modifications, improvements, or impacts to those water resources may require a drainage permit(s) or a construction permit(s) from the OSE. For further information on the OSE's permitting requirements, please visit the Regulation & Appropriation tab on the OSE's website (swc.nd.gov). Please contact the OSE Engineering and Permitting Section at 701-328-2752 if you have any questions regarding this comment.

Thank you for the opportunity to provide review comments. If you have any questions, please call me at 701-328-4967.

Sincerely,

Jared Huijbregtse
Water Resource Planner IV

JH:dm/1570



**STATE
HISTORICAL
SOCIETY
OF NORTH DAKOTA**

Doug Burgum
Governor of North Dakota

North Dakota
State Historical Board

Terrance Rockstad
Bismarck - President

Gereld Gerntholz
Valley City - Vice President

H. Patrick Weir
Medora - Secretary

Calvin Grinnell
New Town

Albert I. Berger
Grand Forks

Steve C. Martens
Fargo

Daniel Stenberg
Watford City

Sara Otte Coleman
*Director
Tourism Division*

Kelly Schmidt
State Treasurer

Alvin A. Jaeger
Secretary of State

Melissa Baker
*Director
Parks and Recreation Department*

Thomas Sorel
*Interim Director
Department of Transportation*

Claudia J. Berg
Director

*Accredited by the
American Alliance
of Museums since 1986*

September 28, 2017

Ms. Melissa Schmit
Senior Permitting Specialist
Harmony Solar
7650 Edinborough Way, Ste 725
Edina, MN 55435

ND SHPO Ref: 17-0373 PSC "Harmony Solar ND, LLC Class I and Class III Inventory in Cass County, North Dakota," in portions of [T140N R51W Sections 10, 11, 16]

Dear Ms. Schmit,

We reviewed ND SHPO Ref: 17-0373 PSC "Harmony Solar ND, LLC Class I and Class III Inventory in Cass County, North Dakota," and find the report acceptable. There has been a good faith effort to identify and avoid impacts to "Significant Sites," provided the project remains as described and mapped in this Area M report dated September & October 2016.

Thank you for the opportunity to review this project. If you have questions please contact either Paul Picha at ppicha@nd.gov or (701) 328-3574 or Susan Quinnell at squinnell@nd.gov or (701) 328-3576.

Sincerely,

Claudia J. Berg
Director, State Historical Society of North Dakota



Board of County Commissioners

Chad M. Peterson
Fargo, North Dakota

Rick Steen
Fargo, North Dakota

Vern Bennett
Fargo, North Dakota

Arland H. Rasmussen
West Fargo, North Dakota

Mary Scherling
Stanley Township, North Dakota

November 6, 2017

North Dakota Public Service Commission
600 East Boulevard Avenue – Dept. 408
Bismarck, ND 58505-0480

Re: Letter of Support for Harmony Solar Project in Cass County

Dear Public Service Commissioners:

The Cass County Commission is aware of and fully supports a permit application that Geronimo Energy plans to submit to the Public Service Commission for the Harmony Solar Project located in Harmony Township. Geronimo Energy has requested this letter of support, and Cass County offers its full support and endorsement of this important economic development opportunity.

Economic development of our rural communities and the responsible, well-planned growth of our tax base is of vital importance to Cass County and our local government partners. According to Geronimo Energy, the construction investment will be approximately \$294 Million. Roughly \$20 Million in local spending will occur during construction.

Once completed, twelve full-time equivalent positions will be needed to operate the project. The following taxing authorities will receive ongoing revenue that is expected to total \$500,000 annually: Central Cass and Mapleton School Districts, Cass County and Harmony Township.

The Cass County Commission supports rural economic development and encourages the North Dakota Public Service Commission to consider the significant impact this project will have on rural Cass County.

Sincerely,

A handwritten signature in black ink, appearing to read "Chad Peterson", written over a circular scribble.

Chad Peterson, Chairman
Cass County Commission

Heather Worden
Commission Assistant

PO Box 2806
211 Ninth Street South
Fargo, North Dakota 58108

701-241-5609
Fax 701-241-5728
www.casscountynd.gov

Harmony Township
Cass County, North Dakota

April 2nd, 2018

North Dakota Public Service Commission
600 East Boulevard Avenue, Department 408
Bismarck, North Dakota 58505

RE: Letter of Support for the Harmony Solar Project in Harmony Township, Cass County

Dear Commissioners,

I am the Chairman of the Harmony Township Board of Supervisors where the Harmony Solar project is being developed. This letter is to share our support for the project and to confirm that Harmony township has approved the Harmony Solar Conditional Use Permit and the project is in compliance with our zoning requirements. This project has the endorsement of the Harmony Township Zoning Board as well as the Board of Supervisors. Several public meetings have been held with Geronimo present and there was no dissention from any residents regarding this project.

I am also a farmer and resident in Harmony Township in Cass County near the proposed Geronimo Energy project referred to as the Harmony Solar Project. I would like to state that my wife Jill and I are in full support of this project in our community and endorse the efforts of Geronimo Energy regarding the solar project. We feel that the economic benefits to the Township, the communities of Mapleton and Casselton as well as Cass County are good for all the entities involved.

Having worked with Geronimo Energy for the better part of two years now, we feel that they have approached this project in a very professional manner from day one. They have been great to work with and we feel they have done their due diligence regarding this project and have answered all the questions that have arisen from residents and entities within the communities involved.

In closing, I would encourage the North Dakota Public Service Commission to approve this project as a beneficial project for the economic growth and development it provides for the betterment of rural Cass County.

Thank you for your time.

Sincerely,

A handwritten signature in black ink, appearing to read "Thomas J. Roden", with a long horizontal flourish extending to the right.

Thomas J. Roden
Chairman of the Harmony Township Board of Supervisors

Casselton Job Development Authority
Casselton, ND 58012

September 26, 2016

Geronimo Energy
7650 Edinborough Way STE 725
Edina, MN 55435

Tena Monson-

On behalf of the Casselton Job Development Authority, I would like to express our support for the Harmony Solar project set to be developed in Cass County. This project will have not only a positive economic impact in our community, but will also have a significant positive impact to the environment. We appreciate the time you have put into developing this project and look forward to working with you in the near future.

Sincerely,

A handwritten signature in black ink, appearing to read 'Jesse Hagen', with a long horizontal line extending to the right.

Jesse Hagen
JDA President

August 31, 2016

Robert and Anne Pyle
Rural Cass County, North Dakota Landowner
Harmony Solar Project Participant

RE: Support of the Harmony Solar Project and Rural Development in Eastern ND

To Whom It May Concern:

We are landowners in Rural Cass County, ND and participants in the Harmony Solar Project. We are writing this letter to show our support for this project. Geronimo has been working with landowners and regulators to ensure that personal property rights and safety of nearby residents are a priority. The economic impact speaks for itself. This project will have a positive effect on our schools, our township, our city, our county and our state.

We encourage your support for the Harmony Solar Project.

Thank you for your time and attention.

Sincerely,

Robert and Anne Pyle

A handwritten signature in blue ink, appearing to read "Robert and Anne Pyle", written over the typed name.

3389 158th Ave. SE
Casselton, ND 58012

Sinner-Bresnahan Land Partnership, LLP

August 30, 2016

Harmony Township/Cass County, North Dakota

RE: Support of the Harmony Solar farm

To whom it may concern,

We are landowners in Harmony Township in Cass County North Dakota and land participants in the Harmony Solar, LLC project. Please view this letter as evidence of our support for this project. This project is a unique opportunity for us to support the efforts to develop clean, quiet and abundant renewable energy sources such as solar. This tract of land is particularly attractive for solar development due to close proximity to the Bison Substation located in Section 11 of Harmony Township.

We feel Geronimo Energy has the capacity to successfully develop this project given their proven track record as the developers of the Courtney Wind farm near Courtney, ND and other solar and wind projects throughout the mid-west. We believe this project will stimulate meaningful economic development for our area which will lead to more opportunities for our residents.

Best Regards,



Bernie Sinner

Managing Agent, Sinner Bresnahan Land Partnership, LLP

From: Miller, Jeffrey D. - NRCS-CD, Fargo, ND
To: [Melissa Schmit](#)
Subject: RE: Harmony Solar - Seed Mixes
Date: Wednesday, May 30, 2018 10:36:58 AM
Attachments: [image001.png](#)

Hi Melissa

Those mixes look excellent. They are well thought out and will grow well in this area. I really like the idea of grazing with sheep. The native grasses evolved with ungulate grazing, and it's awesome that you are thinking about incorporating that into the management plan. Let me know if you need any more help, as I'd be more than happy to help as this project moves forward.

Jeffrey D. Miller

Operations Coordinator
Cass County Soil Conservation District
1665 43rd Street S., Suite 103
Fargo, ND 58103
[701-282-2157 extension 3](tel:701-282-2157)
<http://cassscd.org/>

Like us on Facebook!

<https://www.facebook.com/CassCountySoilConservation>

“Love the trees until their leaves fall off, then encourage them to try again next year.” Chad Sugg

“He plants trees to benefit another generation.” - Caecilius Statius

“Make yourself do a lot of things you’ll be happy to look back on. And make sure you’ve got plans for more of those things in the future.” Steven Rinella

From: Melissa Schmit [mailto:melissa@geronimoenergy.com]
Sent: Tuesday, May 29, 2018 7:09 PM
To: Miller, Jeffrey D. - NRCS-CD, Fargo, ND <Jeffrey.D.Miller@nd.nacdn.net>
Subject: Harmony Solar - Seed Mixes

Hi Jeff,

I am writing to follow up on our conversation a few weeks back regarding proposed seed mixes for the Harmony Solar Project located in Cass County. As we discussed, I have attached our ideal seed mix templates for the Project. Typically our sites have a shorter prairie mix within the panel footprint, taller prairie plantings in the open space between the fence and array, and a wet seed mix for any wetlands or areas anticipated to hold water. Our mixes are designed to be native and promote pollinator habitat - and we work with native prairie specialists to develop our seed mixes.

Their expertise helps design a mix that will achieve our goals for operating the solar facility, promote pollinator habitat, establish stable ground cover successfully, reduce erosion, reduce runoff, and improve infiltration.

Included in the template is two sets of the short, tall, and wet mix. One set reflects a management method of traditional mowing, the other reflects a management method of utilizing sheep as grazers. The main difference between the mowing and grazing is that the grazers will eat all the legumes first, so legumes are cut from the grazing mix and replaced with other species. Our maintenance method has yet to be determined for this site and will not be until closer to operation. As such we are providing mixes for both the mowing and grazing scenario. When you are able, please review the attached lists and let me know if you would recommend any changes.

Thank you,

Melissa Schmit

Senior Permitting Specialist

7650 Edinborough Way, Suite 725

Edina, MN 55435

Main: 952.988.9000

Direct: 612.259.3095

Cell: 952.237.3656

[Geronimo Energy](#)



This electronic message contains information generated by the USDA solely for the intended recipients. Any unauthorized interception of this message or the use or disclosure of the information it contains may violate the law and subject the violator to civil or criminal penalties. If you believe you have received this message in error, please notify the sender and delete the email immediately.

This email has been scanned for spam and viruses by Proofpoint Essentials. Click [here](#) to report this email as spam.

From: Mike Opat
To: [Melissa Schmit](#)
Subject: RE: Harmony Solar - Rush River Water Resource District Coordination
Date: Tuesday, February 14, 2017 2:54:51 PM
Attachments: [image001.png](#)
[8 Bk X-4 Pg 15 - WRD ROW Drawing.pdf](#)
[8 Bk X-4 Pg 15 - WRD ROW Drawing_notes.pdf](#)

Melissa,

The attached PDF includes a few scanned pieces of the overall Lower Rush River (a.k.a. Cass County Drain #2) right of way map on file at the courthouse. This is all we have on file here in our office and I don't believe the water resource district office has anything else on file. I also attached another version with some notes indicating what we believe the section numbers and quarter-quarters. I would recommend obtaining the actual right of way documents from the county recorder's office to official verify the right of widths and locations. The Book and Page information is included in the file name and that should help with the search.

Let me know if you have any questions.

Michael M. Opat, PE, CFM

Senior Project Manager

moore engineering, inc.

Phone 701.282.4692 | Fax 701.282.4530

Direct 701.499.5867 | Cell 507.251.7847

925 10th Ave E, West Fargo, ND 58078

mopat@mooreengineeringinc.com | www.mooreengineeringinc.com

From: Melissa Schmit [mailto:melissa@geronimoenergy.com]

Sent: Tuesday, February 7, 2017 11:09 AM

To: Mike Opat

Cc: (Lewisc@casscountynd.gov); Sean Fredricks (sfredricks@ohnstadlaw.com); Bill Hejl (WAHEJL@aol.com)

Subject: RE: Harmony Solar - Rush River Water Resource District Coordination

Hi Michael,

Thank you for the information pertaining to potential approvals required for the Harmony Solar Project. At this point we have a preliminary design and specific impacts are unknown. I will keep you updated as development continues and will be in touch once the array design is further along to determine what permits will be required. In the meantime, please let me know if I can provide you with information or answer questions the Rush River Water Resource District may have on the Project.

Thank you,

Melissa Schmit

Senior Permitting Specialist

7650 Edinborough Way, Suite 725
Edina, MN 55435
Main: 952.988.9000
Direct: 612.259.3095
Cell: 952.237.3656

[Geronimo Energy](#)



From: Mike Opat [<mailto:MOpat@mooreengineeringinc.com>]
Sent: Friday, January 27, 2017 1:59 PM
To: Melissa Schmit
Cc: (Lewisc@casscountynnd.gov); Sean Fredricks (sfredricks@ohnstadlaw.com); Bill Hejl (WAHEJL@aol.com)
Subject: Harmony Solar - Rush River Water Resource District Coordination

Melissa,

I serve as the engineer for the Rush River Water Resource District and Chairman Hejl passed along your correspondence pertaining to the Harmony Solar project and potential permits that may be required from the Rush River WRD. Without seeing a detailed plan of what you are planning to construct it is tough for us to say what you will need for permits. At this point we can tell you that you'll need a surface drainage permit if you construct any new drains or ditches with a contributing watershed area of 80 acres or more. Improvements (i.e. deepening or widening) of any existing drains may also require a permit. Likewise, subsurface drainage (i.e. tile) facets of your project could require a permit as well. You may also need a Utility Permit from the WRD if you add any inlets into the Rush or Lower Rush Rivers. Construction permits may be required from the Office of the State Engineer if dams, dikes or levees are constructed and they meet certain size thresholds.

Please feel free to contact me with any questions. Thank you.

Michael M. Opat, PE, CFM
Senior Project Manager
moore engineering, inc.

Phone 701.282.4692 | Fax 701.282.4530
Direct 701.499.5867 | Cell 507.251.7847
925 10th Ave E, West Fargo, ND 58078
mopat@mooreengineeringinc.com | www.mooreengineeringinc.com

D

E

F

G

Temporary Easement for
work and storage areas.



Staffs on Rush River
placed in
channel

MI 12

RUSH RIVER

shed and silo.

Perpetual Easement

R.O.W. 140' WIDE OR TO ROAD
OR WHICH EVER IS LEAST

Spoil on right
bank only

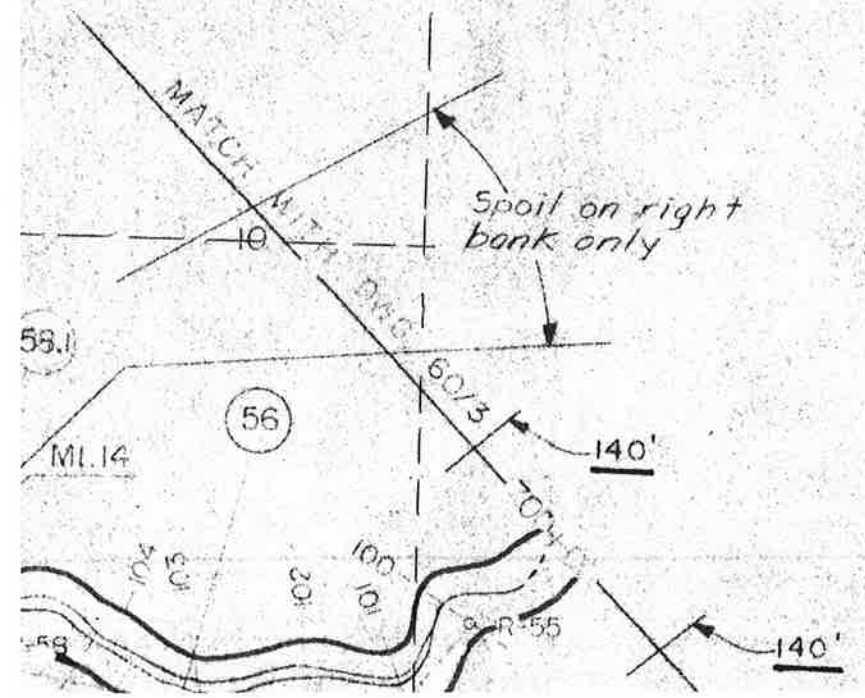

5' CHANNEL BOTTOM

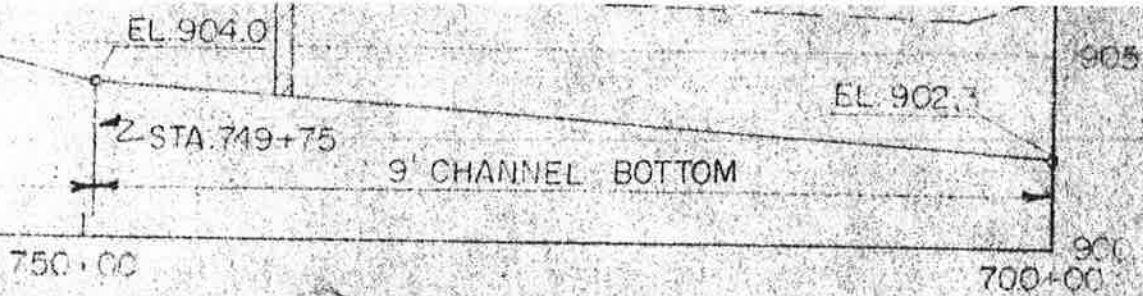

PROFILE

ALONG & OF CHANNEL IMPROVEMENT
LOWER BRANCH

CUTOFF & TRAVERSE-MAIN STEM

STATION	AZIMUTH	DISTANCE	COORDINATES	
			N	E
0+00B	54°34'	269.42	379,490.74	451,049.02
	BEGINNING		379,334.54	450,829.50
	118°27'	990.00		
9+90.00	END		379,806.17	449,959.06
FOLLOWS NATURAL CHANNEL FOR 90.0'				
0+80.00	BEGINNING		379,862.50	449,894.98
	150°03'	252.46		
3+32.46			380,081.25	449,768.95
	150°03'	193.95		
			380,249.30	449,672.13
	82°30'	193.95		
6+74.36B	END		380,223.98	449,479.84
	15°16'	931.76		
			379,325.19	449,234.50



SYMBOL	DESCRIPTION	DATE	APPROVAL
U. S. ARMY ENGINEER DISTRICT, ST. PAUL CORPS OF ENGINEERS ST. PAUL, MINNESOTA			
DESIGNED BY:	FLOOD CONTROL LOWER BRANCH RUSH RIVER, NORTH DAKOTA CHANNEL IMPROVEMENT LOWER BRANCH ALIGNMENT & PROFILE STA. 700+00 TO STA. 906+50		
DRAWN BY:			
CHECKED BY:			
SUBMITTED BY:			
CHIEF F.M.S. BRANCH			
APPROVED:	DATE:	SEPT. 1971	
CHIEF ENGR. DIVISION		SCALE:	SPEC. NO.
REAL ESTATE REQUIREMENTS		AS SHOWN	
		DRAWING NUMBER R23c-N-11/3	
		SHEET	OF

F G

D

E

F

G

Temporary Easement for
work and storage areas.

Staffs on Rush River
placed in
channel



MI 12

RUSH RIVER

shed and silo.

Perpetual Easement

R.O.W. 140' WIDE OR TO ROAD
OR WHICH EVER IS LEAST

Spoil on right
bank only

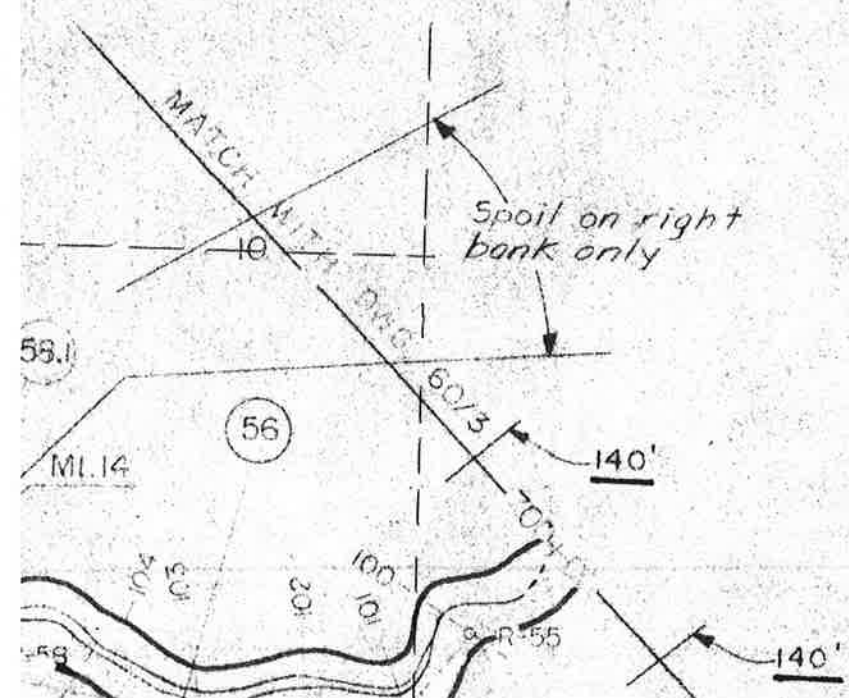

5' CHANNEL BOTTOM

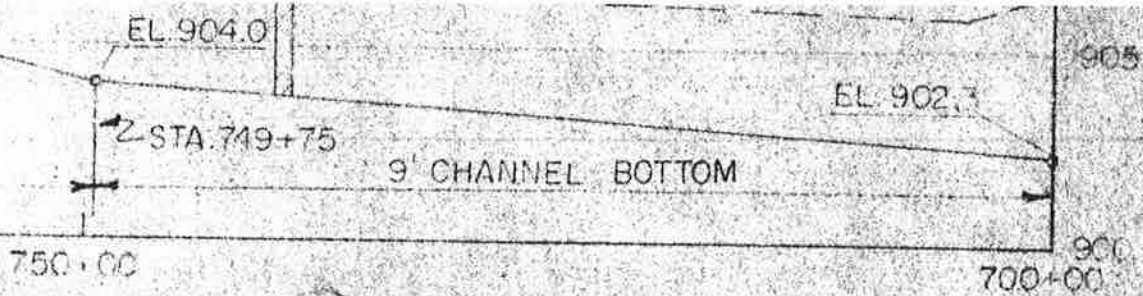

PROFILE

ALONG & OF CHANNEL IMPROVEMENT
LOWER BRANCH

CUTOFF & TRAVERSE-MAIN STEM

STATION	AZIMUTH	DISTANCE	COORDINATES	
			N	E
0+00B	54°34'	269.42	379,490.74	451,049.02
	BEGINNING		379,334.54	450,829.50
9+90.00	118°27'	990.00		
	END		379,806.17	449,959.06
FOLLOWS NATURAL CHANNEL FOR 90.0'				
0+80.00	BEGINNING		379,862.50	449,894.98
	150°03'	252.46		
3+32.46			380,081.25	449,768.95
	150°03'	193.95		
			380,249.30	449,672.13
	82°30'	193.95		
6+74.36B	END		380,223.98	449,479.84
	15°16'	931.76		
			379,325.19	449,234.50



SYMBOL	DESCRIPTION	DATE	APPROVAL
U. S. ARMY ENGINEER DISTRICT, ST. PAUL CORPS OF ENGINEERS ST. PAUL, MINNESOTA			
DESIGNED BY:	FLOOD CONTROL LOWER BRANCH RUSH RIVER, NORTH DAKOTA CHANNEL IMPROVEMENT LOWER BRANCH ALIGNMENT & PROFILE STA. 700+00 TO STA. 906+50		
DRAWN BY:			
CHECKED BY:			
SUBMITTED BY:			
CHIEF F.M.S. BRANCH			
APPROVED:	DATE:	SEPT. 1971	
CHIEF ENGR. DIVISION		SCALE:	SPEC. NO.
REAL ESTATE REQUIREMENTS		AS SHOWN	
		DRAWING NUMBER R23c-N-11/3	
		SHEET	OF

F G

Harmony Solar Project
Appendix D
Glare Analysis



FORGESOLAR GLARE ANALYSIS

Project: **Harmony Solar ND, LLC**

Harmony Solar ND, LLC

Site configuration: **Harmony Solar ND LLC**

Analysis conducted by Phil DeVita (pdevita@hmmh.com) at 18:05 on 16 Apr, 2018.

U.S. FAA 2013 Policy Adherence

The following table summarizes the policy adherence of the glare analysis based on the 2013 U.S. Federal Aviation Administration Interim Policy 78 FR 63276. This policy requires the following criteria be met for solar energy systems on airport property:

- No "yellow" glare (potential for after-image) for any flight path from threshold to 2 miles
- No glare of any kind for Air Traffic Control Tower(s) ("ATCT") at cab height.
- Default analysis and observer characteristics (see list below)

ForgeSolar does not represent or speak officially for the FAA and cannot approve or deny projects. Results are informational only.

COMPONENT	STATUS	DESCRIPTION
Analysis parameters	PASS	Analysis time interval and eye characteristics used are acceptable
Flight path(s)	PASS	Flight path receptor(s) do not receive yellow glare
ATCT(s)	N/A	No ATCT receptors designated

Default glare analysis and observer eye characteristics are as follows:

- Analysis time interval: 1 minute
- Ocular transmission coefficient: 0.5
- Pupil diameter: 0.002 meters
- Eye focal length: 0.017 meters
- Sun subtended angle: 9.3 milliradians

FAA Policy 78 FR 63276 can be read at <https://www.federalregister.gov/d/2013-24729>

SITE CONFIGURATION

Analysis Parameters

DNI: peaks at 1,000.0 W/m²
 Time interval: 1 min
 Ocular transmission coefficient: 0.5
 Pupil diameter: 0.002 m
 Eye focal length: 0.017 m
 Sun subtended angle: 9.3 mrad
 Site Config ID: 17299.2727



PV Array(s)

Name: PV array 1
Description: Tracker
Axis tracking: Single-axis rotation
Tracking axis orientation: 180.0°
Tracking axis tilt: 0.0°
Tracking axis panel offset: 0.0°
Max tracking angle: 65.0°
Resting angle: 65.0°
Rated power: -
Panel material: Smooth glass without AR coating
Reflectivity: Vary with sun
Slope error: correlate with material

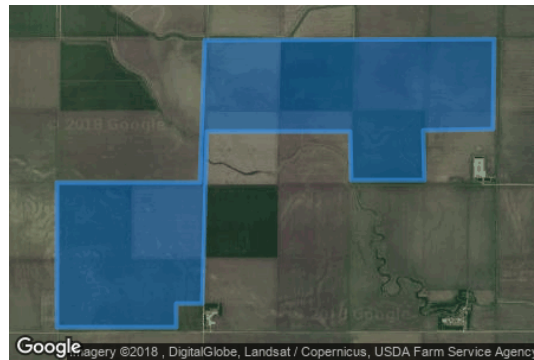

Vertex	Latitude (°)	Longitude (°)	Ground elevation (ft)	Height above ground (ft)	Total elevation (ft)
1	46.935127	-97.137343	919.55	12.00	931.55
2	46.949426	-97.137343	925.75	12.00	937.75
3	46.949426	-97.116572	915.71	12.00	927.71
4	46.963486	-97.115886	916.37	12.00	928.37
5	46.963603	-97.073829	910.52	12.00	922.53
6	46.954699	-97.074000	910.51	12.00	922.51
7	46.954582	-97.084128	914.21	12.00	926.21
8	46.949660	-97.083957	914.75	12.00	926.75
9	46.949660	-97.094600	913.51	12.00	925.51
10	46.954464	-97.094771	916.29	12.00	928.29
11	46.954464	-97.115543	917.76	12.00	929.76
12	46.937472	-97.116229	917.80	12.00	929.80
13	46.937472	-97.120006	919.91	12.00	931.91
14	46.935127	-97.120006	918.51	12.00	930.51

Flight Path Receptor(s)

Name: RWY 17

Description:

Threshold height: 50 ft

Direction: °

Glide slope: 3.0°

Pilot view restricted? Yes

Vertical view: 30.0°

Azimuthal view: 90.0°



Point	Latitude (°)	Longitude (°)	Ground elevation (ft)	Height above ground (ft)	Total elevation (ft)
Threshold	46.905566	-97.098284	911.75	50.00	961.75
Two-mile	46.934369	-97.101977	914.33	600.87	1515.21

Name: RWY 35

Description:

Threshold height: 50 ft

Direction: °

Glide slope: 3.0°

Pilot view restricted? Yes

Vertical view: 30.0°

Azimuthal view: 90.0°

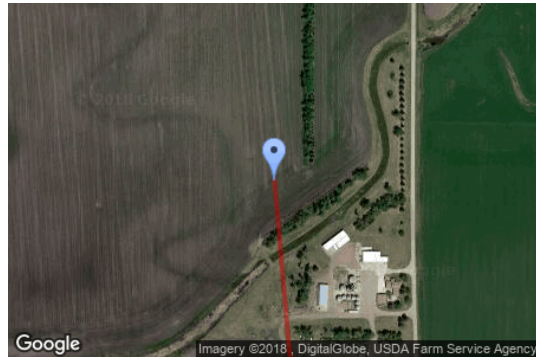

Point	Latitude (°)	Longitude (°)	Ground elevation (ft)	Height above ground (ft)	Total elevation (ft)
Threshold	46.899927	-97.097769	913.49	50.00	963.49
Two-mile	46.871124	-97.094077	900.90	616.05	1516.94

GLARE ANALYSIS RESULTS

Summary of Glare

PV Array Name	Tilt (°)	Orient (°)	"Green" Glare min	"Yellow" Glare min	Energy kWh
PV array 1	SA tracking	SA tracking	0	0	-

Total annual glare received by each receptor

Receptor	Annual Green Glare (min)	Annual Yellow Glare (min)
RWY 17	0	0
RWY 35	0	0

Results for: PV array 1

Receptor	Green Glare (min)	Yellow Glare (min)
RWY 17	0	0
RWY 35	0	0

Flight Path: RWY 17

0 minutes of yellow glare

0 minutes of green glare

Flight Path: RWY 35

0 minutes of yellow glare

0 minutes of green glare

Assumptions

"Green" glare is glare with low potential to cause an after-image (flash blindness) when observed prior to a typical blink response time.

"Yellow" glare is glare with potential to cause an after-image (flash blindness) when observed prior to a typical blink response time.

Times associated with glare are denoted in Standard time. For Daylight Savings, add one hour.

Glare analyses do not account for physical obstructions between reflectors and receptors. This includes buildings, tree cover and geographic obstructions.

The glare hazard determination relies on several approximations including observer eye characteristics, angle of view, and typical blink response time. Actual values may differ.

Hazard zone boundaries shown in the Glare Hazard plot are an approximation and visual aid based on aggregated research data. Actual ocular impact outcomes encompass a continuous, not discrete, spectrum.

2015-2017 © Sims Industries, All Rights Reserved.

Harmony Solar Project
Appendix F
Wetland Delineation Report

Wetland Delineation

Harmony Solar ND Project
Harmony Facility
Cass County, North Dakota



Prepared for:
Harmony Solar ND, LLC
7650 Edinborough Way, Suite 725
Edina, MN 55435

Prepared by:
Stantec Consulting Services Inc.
2300 Swan Lake Blvd., Suite 202
Independence, IA 50644
Phone: (319) 334-3755
Fax: (319) 334-3780

Project #193704812

May 2, 2018

WETLAND DELINEATION

Table of Contents

1.0	INTRODUCTION	1
1.1	PROJECT DESCRIPTION	1
1.2	PURPOSE OF THE PROJECT	1
2.0	METHODS.....	1
2.1	WETLANDS.....	1
2.1.1	Agricultural Land Determinations	1
2.1.2	Routine On-Site Determinations	2
2.2	WATERS OF THE U.S.	3
2.3	WOODLANDS AND NOXIOUS WEEDS.....	3
3.0	RESULTS	4
3.1	LANDSCAPE SETTING	4
3.2	POTENTIAL WETLAND SIGNATURES INVESTIGATED	4
3.2.1	Section 16.....	4
3.2.2	Section 10.....	4
3.2.3	Section 11	5
3.3	WATERS OF THE U.S.	5
3.4	WOODLANDS AND NOXIOUS WEEDS.....	5
4.0	CONCLUSIONS AND RECOMMENDATIONS.....	6
5.0	LITERATURE CITED	6

LIST OF FIGURES

- Figure 1. Project Location and Topography
- Figure 2. NRCS Soil Survey Data Hydric Ratings
- Figure 3. National Wetlands Inventory
- Figure 4. Field Collected Data

LIST OF APPENDICES

- Appendix A - Data Forms
- Appendix B - Site Photographs

WETLAND DELINEATION

1.0 INTRODUCTION

1.1 PROJECT DESCRIPTION

Stantec Consulting Services Inc. (Stantec) performed a delineation of wetland boundaries within the project boundary of the proposed Harmony Solar ND Project (Project) (Figure 1). The proposed facility is located east of Casselton, North Dakota in Sections 10, 11, and 16, Township 140 N, Range 51W in Cass County (Figure 1). The project area is approximately 1,670 acres in size and consists entirely of active agricultural fields planted in crops in 2016. The project boundary includes a proposed access corridor that extends across the Lower Branch Rush River from the NE ¼ of the NE ¼ of Section 16 to the SW ¼ of the SW ¼ of Section 10 (Figures 2 through 4).

This report presents the methodology, results and conclusions of the field investigation.

1.2 PURPOSE OF THE PROJECT

The purpose of this investigation was to determine if wetlands and other Waters of the U.S. (i.e., streams) are present within the project boundary and delineate the boundaries of any such wetlands and waterways found.

2.0 METHODS

2.1 WETLANDS

The U.S. Army Corps of Engineers (USACE) and U.S. Environmental Protection Agency define a wetland as:

“Areas that are inundated or saturated by surface or ground water at a frequency and duration sufficient to support, and under normal circumstances do support a prevalence of vegetation typically adapted for life in saturated soil conditions.”

The initial steps in the wetland determination process included a review of the following documents:

- Cass County Soil Survey (USDA 2015) (Figure 2)
- Natural Resources Conservation Service (NRCS) list of hydric soil for Cass County (USDA 2015) (Figure 2)
- U.S. Fish and Wildlife Service National Wetlands Inventory (NWI) Data (Figure 3)
- NRCS Farm Service Agency (FSA) aerial imagery

These documents provide information on where wetlands have been previously identified or areas that possess a high likelihood of wetlands occurring.

2.1.1 Agricultural Land Determinations

Wetland determinations on agricultural land were conducted using conventions developed by the USDA-NRCS and accepted by the USACE.

WETLAND DELINEATION

2.1.1.1 Off-Site Determinations

The NRCS Fargo Field Office supplied an evaluation of conditions with regard to rainfall data for the Chaffee 5 NE Weather Station (Station Number: ND1477) and all available aerial images dating back to 1980 (31 available years). A review of normal conditions in July for Weather Station ND1477 concluded 16 years met the NRCS climatic evaluation of normal (1980, 1981, 1983, 1984, 1985, 1987, 1990, 1992, 1995, 1996, 1997, 1999, 2002, 2004, 2009, and 2010).

NWI and hydric soil data were overlaid on the photo base map (NAIP 2015). Areas of potential wetland were identified within the project boundary by interpreting wetness signatures visible on aerial photographs of normal years. Wet signatures that were visible in at least 50 percent of normal year aerial photographs were marked for field investigation as discussed in Section 2.1.1.2.

A wetland signature is the suggestion of wetland hydrology as evidenced by features observable on the aerial photo such as standing water, crop stress (different color or tone), or lack of crop growth (exposed soil within partially cropped area), especially if supported by soil survey data.

Based on the field visit, it is obvious that the landscape within the survey area has been subject to agricultural practices for the production of crops (i.e., plowing, tilling, and potentially drainage practices). Therefore, hydric soil boundaries do not always compare with the boundaries of remnant wetlands. See Section 2.1.1.2 for methods regarding hydric soil verification within agricultural fields.

2.1.1.2 Hydric Soil Field Verification

Following the office determination, a site visit was made to field verify the presence of hydric soils in areas where potential wetland signatures were observed in at least 50 percent of the aerial photos examined.

Field verification consisted of sampling a minimum of one point at the lowest local topographical relief within the potential wetland boundary to confirm the presence of hydric soils. These areas were mapped using the limits of the aerial delineation at each location if applicable. It is not known at this time if NRCS has completed a Certified Wetland Determination for this property.

2.1.2 Routine On-Site Determinations

Wetland determinations were conducted using the Routine On-Site Determination Method defined in the U.S. Army Corps of Engineers Wetland Delineation Manual (Environmental Laboratory 1987), subsequent guidance documents (USACE 1991, 1992) and the Regional Supplement to the Corps of Engineers Wetland Delineation Manual: Great Plains Region (USACE 2010). According to procedures described in this Manual, areas that under normal circumstances reflect a predominance of hydrophytes (e.g., water-loving vegetation), hydric soils, and wetland hydrology (e.g., inundated or saturated soils) are considered wetlands.

Stantec completed the following at each observation point.

1. The presence or absence of normal circumstances was determined.
2. The plant community was characterized by identifying dominant plant species using the "50/20" rule and, in some cases, the FAC-neutral test. The 50/20 rule is conducted by placing plant species present (in each stratum) in a list. The plants are listed in decreasing order of abundance. The dominant plant species are identified as those plants constituting the first half of the total species present when the number of species is totaled

WETLAND DELINEATION

from the most abundant to the least abundant. Any of the remaining species that exceed 20 percent of the total are also dominant species. A wetland indicator status is determined and recorded for each dominant species. Wetland indicator status is ranked by percent probability of the species occurrence in wetlands as follows:

OBL = Obligate Wetland, occurs with an estimated 99 percent probability of occurrence in wetlands

FACW = Facultative Wetland, estimated 67 to 99 percent probability of occurrence in wetlands

FAC = Facultative equally likely to occur in wetlands and non-wetlands (34 to 66 percent probability)

FACU = Facultative upland, 67 to 99 percent probability in non-wetlands, 1 to 33 percent in wetlands

UPL = Obligate Upland, greater than 99 percent probability in non-wetlands in this region

NI = No indicator, insufficient information available to determine an indicator status

3. Soil pits were dug to a depth of at least 16 inches and the soil was evaluated for hydric soil characteristics.
4. Hydrology was assessed by observing for primary (e.g., inundation, saturation within the root zone, water marks, etc.) and secondary (e.g., oxidized pore linings, water stained leaves, etc.) indicators of wetland hydrology.

A wetland delineation was conducted by qualified Stantec biologists on October 20, 2016 within the project boundary (Figure 1). A minimum of one wetland and one non-wetland point were sampled at each wetland where applicable. Wetlands were classified using the Cowardin et al. (1979) system. Data forms are included in Appendix A. Representative site photographs are included in Appendix B.

2.2 WATERS OF THE U.S.

All “blue line” streams identified on U.S. Geological Survey (USGS) 1:24,000 Scale Topographic Maps were investigated in the field. A stream was considered to be a Waters of the U.S. if it had a defined bed and bank, an ordinary high water mark, and appeared to be actively sorting sediment.

2.3 WOODLANDS AND NOXIOUS WEEDS

On April 26, 2018, Geronimo contacted Stantec to update the original wetland delineation report dated November 16, 2016. Though natural community (non-cropped lands other than wetlands) and noxious weed surveys were not conducted during the 2016 fieldwork, the purpose of this update is to present field observations of woodlands or noxious weeds incidentally recorded during the wetland delineation.

WETLAND DELINEATION

3.0 RESULTS

3.1 LANDSCAPE SETTING

The landscape within the project boundary is described as glaciolacustrine plains with 0-2% slopes (USDA, NRCS; Soil Survey Data Cass County). Land use within the project boundary consists entirely of agricultural fields planted in corn, soybeans, and wheat in 2016. A review of aerial photographs indicates land within the project boundary has been farmed since before 1980. Due to anthropogenic modifications (i.e., tilling and drainage practices), the site is well drained in areas with hydric soil classification; therefore, field conditions observed at the site are not consistent with hydric soil boundaries shown on Figure 2.

NWI maps indicate several small wetlands within the project boundary (Figure 3). The most prominent of these features is the Lower Branch Rush River classified as R4SBcx and is discussed further in Section 3.4. Other NWI-indicated wetlands were investigated in the field (sample points u1, u2, u3, u15, u17, and u21, Figure 4; Appendix A) and none were determined to be wetland.

3.2 POTENTIAL WETLAND SIGNATURES INVESTIGATED

Twelve potential wetland signatures were visible on at least 50 percent of the aerial photographs examined within the project boundary during the desktop review. Sampling points were taken at 21 locations within the project boundary to field confirm the presence of hydric soils at these locations (Figure 4); however, no hydric soil field indicators were met. The results of the field investigation of soils are discussed in Section 3.2.1 through 3.2.3 below.

3.2.1 Section 16

Five potential wetland signatures located proximally to an apparent drainage feature were identified during the aerial review. Upon field examination, the drainage features visible on aerial imagery are indistinguishable to the eye and were successfully cropped in 2016. Six sample points (u4 – u9, Figure 4; Appendix A) were taken in these areas and no hydric soil field indicators were observed (Appendix A). These areas were determined to be non-wetland.

3.2.2 Section 10

Three potential wetland signatures were identified in Section 10 during the aerial review. The first, located in the NW $\frac{1}{4}$ of the NW $\frac{1}{4}$ of the section, is a drainage feature visible on aerial imagery. Upon field investigation, this feature is found in the vicinity of a minor swale with one percent slope differentiation from surrounding topography and was successfully cropped in 2016. Two sample points (u11 and u12, Appendix A; Figure 4) were taken in the two lowest topological points of the drainage feature; no hydric soil field indicators were documented at this locations.

A second potential wetland signature was identified in the NE $\frac{1}{4}$ of the NW $\frac{1}{4}$ near the section road. The sampling point was taken within a minor depression that was successfully cropped in 2016. Hydrology indications of salt crust and its relative geomorphic position suggest this is an area towards which water will drain and potentially pond until evaporated or drained. No hydric soil field indicators were met at this location (sample point (u13, Figure 4; Appendix A) It is assumed this area is not inundated or saturated for a long enough duration during the growing season for redoximorphic features (i.e., mottles or depletions) to develop. This area was determined to be non-wetland.

WETLAND DELINEATION

A third potential wetland signature is located in an undeveloped swale near the toe slope of 161st Avenue SE in the NE ¼ of the SE ¼. Aerial imagery suggests a drainage feature comes to an end into the roadside ditch. This area was successfully cropped in 2016 and no distinguishable topographic change was observed at this location in the field. No hydric soil field indicators were observed at sample point u14 (Figure 4; Appendix A) taken in this area; therefore, this area was determined to be non-wetland.

3.2.3 Section 11

Three potential wetland signatures were identified in Section 11 during the aerial review. In the SW ¼ of the section, a drainage feature is located within a minor swale with an approximate one percent slope differentiation from surrounding topography and was successfully cropped in 2016. No hydric soil field indicators were met at this location (sampling point u18, Figure 4; Appendix A).

Two potential wetland signatures were identified in areas successfully cropped in 2016: one, located in the NE ¼ of the SE ¼ of the section near the toe slope of 162nd Avenue SE, and the second located in the NW ¼ of the SE ¼ of this section. These areas have a less than one percent change in topography when compared to the surrounding landscape. No hydric soil field indicators were met at either location (samplings points u19 and u20, Figure 4; Appendix A); therefore, these areas were determined to be non-wetland.

3.3 WATERS OF THE U.S.

One "blue line" stream, the Lower Branch Rush River, is mapped as an intermittent waterway on USGS 1:24,000 scale topographic maps within the project boundary and was field confirmed to be present (Figure 4). This stream has a defined bed, bank and ordinary high water mark and had flowing water on the day of the fieldwork; therefore, this stream meets waters of the U.S. criteria.

Within the project boundary, the channel is deeply incised with wetland vegetation located below the ordinary high water mark on the river banks (sample points w1 and w2, Appendix A; Figure 4). Because these points were taken below the ordinary high water mark of the stream, this feature was mapped as a field identified waterway on Figure 4 and is not identified as a wetland.

3.4 WOODLANDS AND NOXIOUS WEEDS

A review of 2015 aerial photography (Figure 4) indicates land within the project boundary is entirely agricultural. No woodland communities are visible on aerial photographs, and no such communities were identified as a result of the 2016 fieldwork within the project boundary (Figure 4).

The North Dakota Department of Agriculture maintains a list of plants identified as noxious weeds (<https://www.nd.gov/ndda/plant-industries/noxious-weeds>). None of these species were recorded at any of the sampling points investigated within the project boundary in 2016 (Appendix A). Vegetation within the roadside ditches was observed to be primarily smooth brome (*Bromus inermis*) in 2016.

WETLAND DELINEATION

4.0 CONCLUSIONS AND RECOMMENDATIONS

An aerial review and field investigation identified no wetlands within the project boundary. One stream, the Lower Branch Rush River, meets Waters of the U.S. criteria and was identified within the project boundary. No woodland communities are visible on aerial photographs, and no such communities were identified as a result of the 2016 fieldwork within the project boundary (Figure 4). No noxious weeds were recorded at any of the sampling points investigated within the project boundary in 2016.

The USACE has regulatory authority over waters of the U.S. including adjacent wetlands. Prior to beginning work at this site or disturbing or altering wetlands, waterways, or adjacent lands in any way, Stantec recommends that the owner obtain the necessary permits or other agency regulatory review and concurrence with regard to the proposed work to comply with applicable regulations.

The information provided by Stantec regarding wetland boundaries and waterways is a scientific-based analysis of the wetland and upland conditions present on the site at the time of the fieldwork. The delineation was performed by experienced and qualified professionals using standard practices and sound professional judgment. The ultimate decision on wetland boundaries rests with the USACE. As a result, there may be adjustments to boundaries based upon review by a regulatory agency. An agency determination can vary from time to time depending on various factors including, but not limited to, recent precipitation patterns and season of the year. In addition, the physical characteristics of the site can change over time, depending on weather, vegetation patterns, drainage activities on adjacent parcels, or other events. These factors can change the nature and extent of wetlands on the site.

5.0 LITERATURE CITED

- Cowardin, L.M., V. Carter, F.C. Golet and E.T. LaRoe. 1979. Classification of Wetland and Deepwater Habitats of the United States. FWS/OBS-79/31. U.S. Fish and Wildlife Service, Office of Biological Services. Washington D.C.
- Environmental Laboratory. 1987. Corps of Engineers Wetland Delineation Manual. Technical Report Y-87-1. U.S. Army Corps of Engineers Waterways Experiment Station. Vicksburg, MS.
- U.S. Army Corps of Engineers. 2014. State of North Dakota 2014 Wetland Plant List. Lichvar, R.W., M. Butterwick, N.C. Melvin, and W.N. Kirchner. *The National Wetland Plant List: 2014 Update of Wetland Ratings*. Phytoneuron 2014-41: 1-42
- U.S. Army Corps of Engineers. 2010. Regional Supplement to the Corps of Engineers Wetland Delineation Manual: Great Plains Region (Version 2.0), ed. J.S. Wakeley, R.W. Lichvar, and C.V. Noble. ERDC/EL TR-10-1. Vicksburg, MS: U.S. Army Engineer Research and Development Center.
- U.S. Department of Agriculture, Natural Resources Conservation Service. 2015. Soil Survey Data from Cass County, North Dakota (Digital Format).

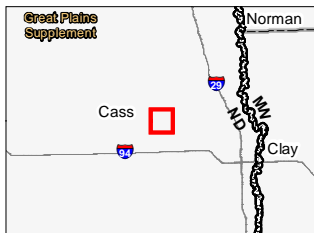
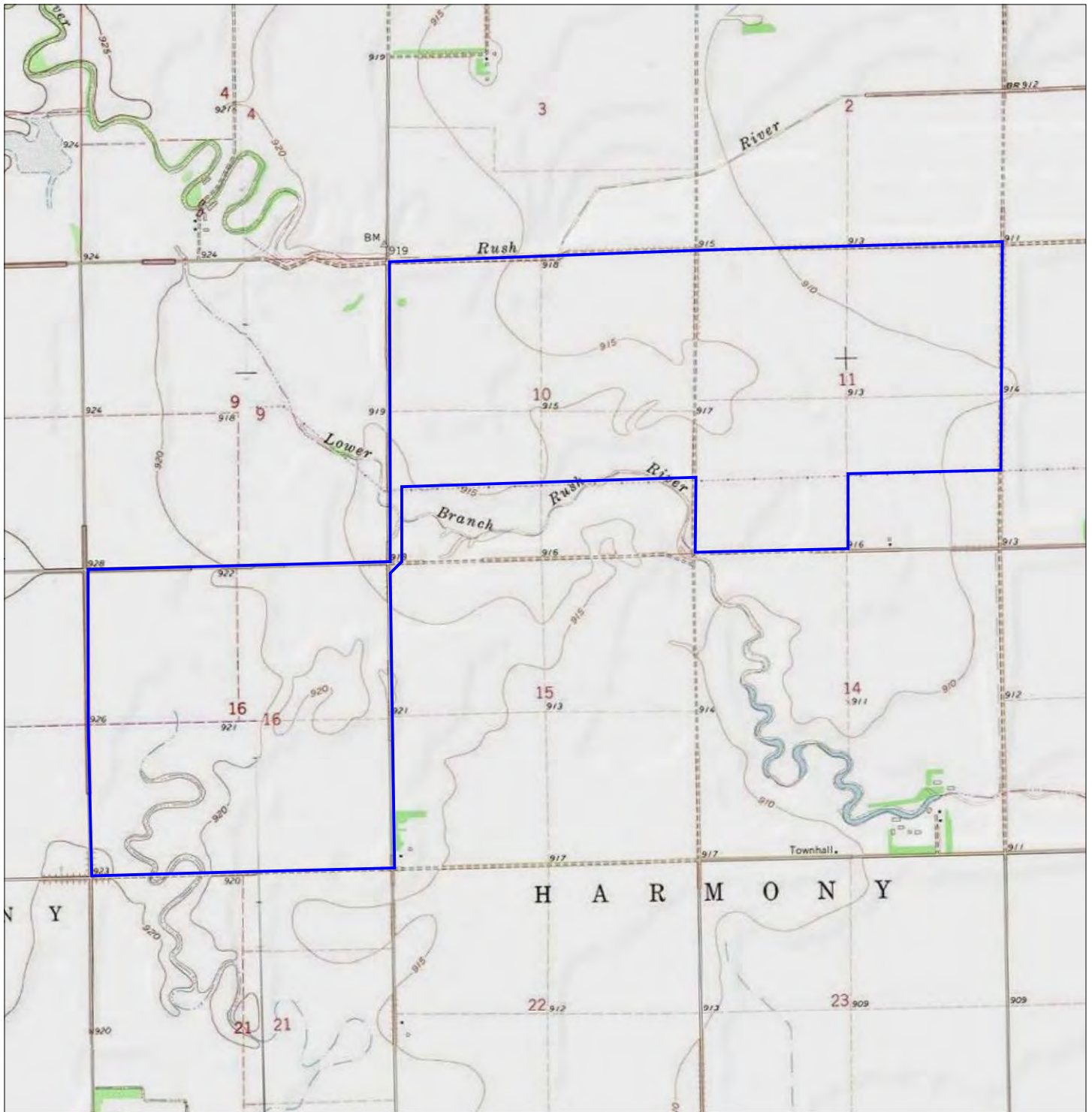

Legend
 Approximate Project Boundary

- Notes**
1. Coordinate System: NAD 1983 UTM Zone 14N
 2. Data Sources Include: Stantec, Geronimo, NADS
 3. Background: USGS 7.5' Topographic Quadrangles

Disclaimer: Stantec assumes no responsibility for data supplied in electronic format. The recipient accepts full responsibility for verifying the accuracy and completeness of the data. The recipient releases Stantec, its officers, employees, consultants and agents, from any and all claims arising in any way from the content or provision of the data.

Figure No. **1**

Title
Project Location and Topography

Client/Project
 Geronimo Wind Energy, LLC
 Harmony Solar Project

Project Location 193704812
 T140N, R51W, S10, 11, 16 Prepared by MCP on 2016-10-27
 Cass Co., ND Technical Review by MP on 2016-10-27
 Independent Review by JS on 2016-11-02

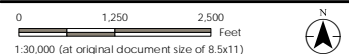

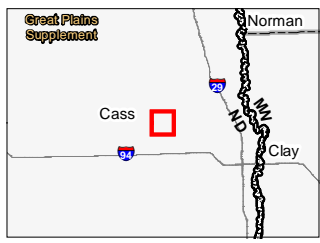
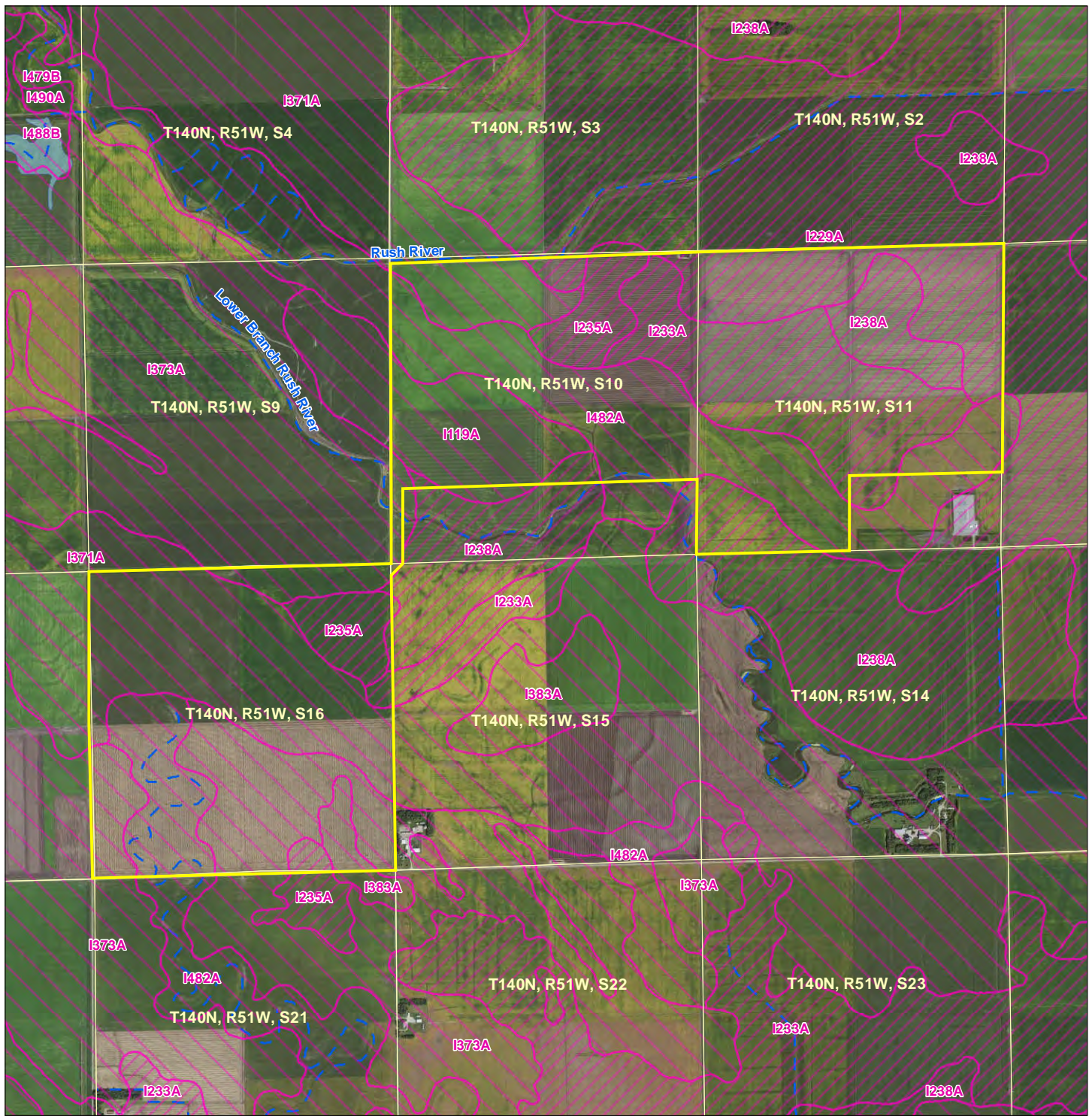

Legend

- Approximate Project Boundary
- National Hydrography Dataset
- ~ Perennial Stream
- - - Intermittent Stream
- Waterbody
- Predominantly Hydric Soils
- Partially Hydric Soils
- Non-Hydric Soils

Notes

1. Coordinate System: NAD 1983 UTM Zone 14N
2. Data Sources Include: Stantec, Geronimo, USGS, NADS, NRCS
3. Orthophotography: 2015 NAP

Disclaimer: Stantec assumes no responsibility for data supplied in electronic format. The recipient accepts full responsibility for verifying the accuracy and completeness of the data. The recipient releases Stantec, its officers, employees, consultants and agents, from any and all claims arising in any way from the content or provision of the data.

Figure No. **2**

Title
**NRCS Soil Survey Data
Hydric Ratings**

Client/Project
Geronimo Wind Energy, LLC
Harmony Solar Project

Project Location: 193704812
T140N, R51W, S10, 11, 16 Prepared by MCP on 2016-10-27
Cass Co., ND Technical Review by MP on 2016-10-27
Independent Review by JS on 2016-11-02

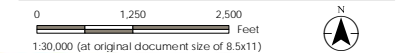

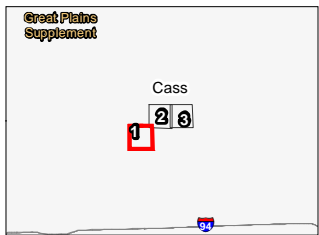
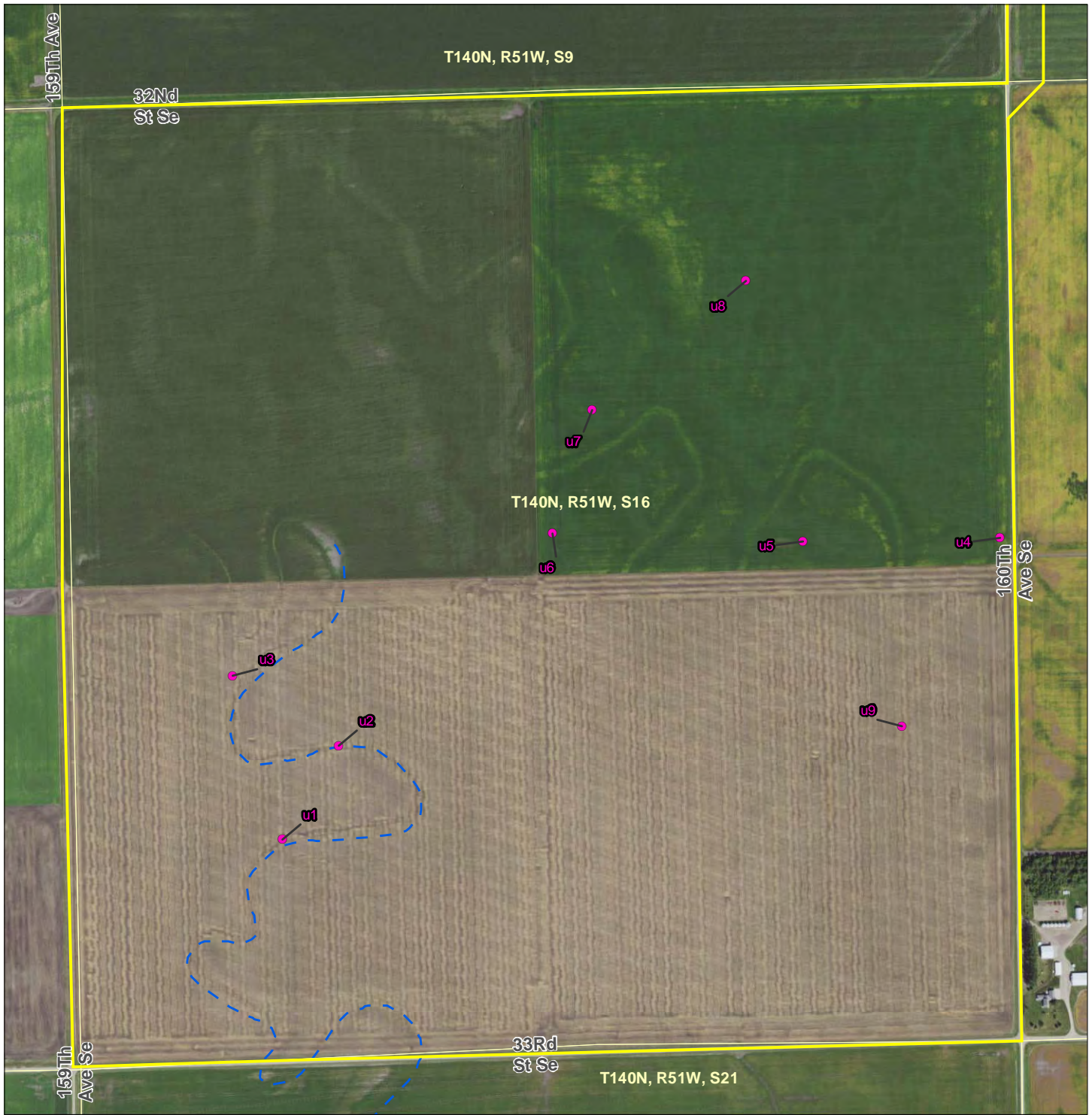

- Notes**
1. Coordinate System: NAD 1983 UTM Zone 14N
 2. Data Sources Include: Stantec, Geronimo, USGS, NADS
 3. Orthophotography: 2015 NAIIP

Disclaimer: Stantec assumes no responsibility for data supplied in electronic format. The recipient accepts full responsibility for verifying the accuracy and completeness of the data. The recipient releases Stantec, its officers, employees, consultants and agents, from any and all claims arising in any way from the content or provision of the data.

- Legend**
- Approximate Project Boundary
 - Sample Point
 - Field Identified Waterway
 - ~ National Hydrography Dataset Perennial Stream
 - - - Intermittent Stream
 - ☪ Waterbody

Figure No. **4**

Title
Field Collected Data

Client/Project
Geronimo Wind Energy, LLC
Harmony Solar Project

Project Location
T140N, R51W, S10, 11, 16
Cass Co., ND

193704812
Prepared by MCP on 2016-10-27
Technical Review by MP on 2016-10-27
Independent Review by JS on 2016-11-02





Great Plains Supplement

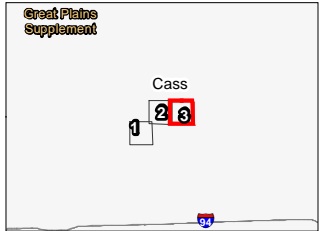

- Notes
1. Coordinate System: NAD 1983 UTM Zone 14N
 2. Data Sources Include: Stantec, Geronimo, USGS, NADS
 3. Orthophotography: 2015 NAIP

Disclaimer: Stantec assumes no responsibility for data supplied in electronic format. The recipient accepts full responsibility for verifying the accuracy and completeness of the data. The recipient releases Stantec, its officers, employees, consultants and agents, from any and all claims arising in any way from the content or provision of the data.

Legend

- Approximate Project Boundary
- Sample Point
- Field Identified Waterway
- National Hydrography Dataset Perennial Stream
- Intermittent Stream
- Waterbody

Figure No.
4

Title
Field Collected Data

Client/Project
Geronimo Wind Energy, LLC
Harmony Solar Project

Project Location 193704812
T140N, R51W, S10, 11, 16 Prepared by MCP on 2016-10-27
Cass Co., ND Technical Review by MP on 2016-10-27
Independent Review by JS on 2016-11-02

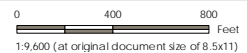

APPENDIX A

Data Forms

Project/Site: Harmony Solar Array	Stantec Project #: 193704812	Date: 10/20/16
Applicant: Harmony Solar ND LLC	Investigator #1: Joseph Sander	County: Cass
Soil Unit: I482A Overly Bearden silt loams	Investigator #2:	State: North Dakota
Landform: Flats	Local Relief: Concave	Wetland ID: N/A
Slope (%): 0-2	Latitude: --	Sample Point: U1
	Longitude: --	Community ID: Agricultural commodity
Are climatic/hydrologic conditions on the site typical for this time of year? (If no, explain in remarks) <input checked="" type="checkbox"/> Yes <input type="checkbox"/> No		Section: 16
Are Vegetation <input checked="" type="checkbox"/> , Soil <input checked="" type="checkbox"/> , or Hydrology <input checked="" type="checkbox"/> significantly disturbed?		Township: 140N
Are Vegetation <input type="checkbox"/> , Soil <input type="checkbox"/> , or Hydrology <input type="checkbox"/> naturally problematic?		Range: \$1W Dir: --
Are normal circumstances present? <input type="checkbox"/> Yes <input checked="" type="checkbox"/> No		

SUMMARY OF FINDINGS

Hydrophytic Vegetation Present? <input type="checkbox"/> Yes <input checked="" type="checkbox"/> No	Hydric Soils Present? <input type="checkbox"/> Yes <input checked="" type="checkbox"/> No
Wetland Hydrology Present? <input type="checkbox"/> Yes <input checked="" type="checkbox"/> No	Is This Sampling Point Within A Wetland? <input checked="" type="checkbox"/> Yes <input type="checkbox"/> No

Remarks: **Sample point is located in a successfully cropped area of an agricultural field subjected to frequent tilling.**

HYDROLOGY

Wetland Hydrology Indicators (Check here if indicators are not present):

<p><u>Primary:</u></p> <ul style="list-style-type: none"> <input type="checkbox"/> A1 - Surface Water <input type="checkbox"/> A2 - High Water Table <input type="checkbox"/> A3 - Saturation <input type="checkbox"/> B1 - Water Marks <input type="checkbox"/> B2 - Sediment Deposits <input type="checkbox"/> B3 - Drift Deposits <input type="checkbox"/> B4 - Algal Mat or Crust <input type="checkbox"/> B5 - Iron Deposits <input type="checkbox"/> B7 - Inundation Visible on Aerial Imagery <input type="checkbox"/> B9 - Water Stained Leaves 	<ul style="list-style-type: none"> <input type="checkbox"/> B11 - Salt Crust <input type="checkbox"/> B13 - Aquatic Invertebrates <input type="checkbox"/> C1 - Hydrogen Sulfide Odor <input type="checkbox"/> C2 - Dry-Season Water Table <input type="checkbox"/> C3 - Oxidized Rhizospheres on Living Roots (where not tilled) <input type="checkbox"/> C4 - Presence of Reduced Iron <input type="checkbox"/> C7 - Thin Muck Surface <input type="checkbox"/> Other (Explain in Remarks) 	<p><u>Secondary:</u></p> <ul style="list-style-type: none"> <input type="checkbox"/> B6 - Surface Soil Cracks <input type="checkbox"/> B8 - Sparsely Vegetated Concave Surface <input type="checkbox"/> B10 - Drainage Patterns <input type="checkbox"/> C3 - Oxidized Rhizospheres on Living Roots (where tilled) <input type="checkbox"/> C8 - Crayfish Burrows <input type="checkbox"/> C9 - Saturation Visible on Aerial Imagery <input checked="" type="checkbox"/> D2 - Geomorphic Position <input type="checkbox"/> D5 - FAC-Neutral Test <input type="checkbox"/> D7 - Frost-Heave Hummocks (LRR F)
---	--	--

Field Observations: Surface Water Present? <input type="checkbox"/> Yes <input checked="" type="checkbox"/> No Depth: 0 (in.) Water Table Present? <input type="checkbox"/> Yes <input checked="" type="checkbox"/> No Depth: >24 (in.) Saturation Present? <input type="checkbox"/> Yes <input checked="" type="checkbox"/> No Depth: >24 (in.)	Wetland Hydrology Present? <input type="checkbox"/> Yes <input checked="" type="checkbox"/> No
--	---

Describe Recorded Data (stream gauge, monitoring well, aerial photos, previous inspections), if available: **N/A**

Remarks: **Sample point is within a minor swale (4 ft wide) with 1% slope differentiation from topographical surroundings**

SOILS

Map Unit Name: **I482A Overly Bearden silt loams** Series Drainage Class: **Moderately Well Drained**

Taxonomy (Subgroup):

Profile Description (Describe to the depth needed to document the indicator or confirm the absence of indicators.) (Type: C=Concentration, D=Depletion, RM=Reduced Matrix, CS=Covered/Coated Sand Grains, Location: PL=Pore Lining, M=Matrix)

Top Depth	Bottom Depth	Horizon	Matrix			Redox Features				Texture (e.g. clay, sand, loam)	
			Color (Moist)	%		Color (Moist)	%	Type	Location		
0	8	Ap	10YR	2/1	100	--	None	--	--	--	silt loam
8	24	A	10YR	2/1	100	--	None	--	--	--	silt loam
--	--	--	--	--	--	--	--	--	--	--	--
--	--	--	--	--	--	--	--	--	--	--	--
--	--	--	--	--	--	--	--	--	--	--	--
--	--	--	--	--	--	--	--	--	--	--	--
--	--	--	--	--	--	--	--	--	--	--	--

NRCS Hydric Soil Field Indicators (check here if indicators are not present):

<ul style="list-style-type: none"> <input type="checkbox"/> A1 - Histosol <input type="checkbox"/> A2 - Histic Epipedon <input type="checkbox"/> A3 - Black Histic <input type="checkbox"/> A4 - Hydrogen Sulfide <input type="checkbox"/> A5 - Stratified Layers (LRR F) <input type="checkbox"/> A9 - 1 cm Muck (LRR F, G, H) <input type="checkbox"/> A11 - Depleted Below Dark Surface <input type="checkbox"/> A12 - Thick Dark Surface <input type="checkbox"/> S1 - Sandy Muck Mineral <input type="checkbox"/> S2 - 2.5 cm Mucky Peat or Peat (LRR G, H) 	<ul style="list-style-type: none"> <input type="checkbox"/> S3 - 5cm Mucky Peat or Peat (LRR F) <input type="checkbox"/> S4 - Sandy Gleyed Matrix <input type="checkbox"/> S5 - Sandy Redox <input type="checkbox"/> S6 - Stripped Matrix <input type="checkbox"/> F1 - Loamy Mucky Mineral <input type="checkbox"/> F2 Loamy Gleyed Matrix <input type="checkbox"/> F3 - Depleted Matrix <input type="checkbox"/> F6 - Redox Dark Surface <input type="checkbox"/> F7 - Depleted Dark Surface <input type="checkbox"/> F8 - Redox Depressions 	<ul style="list-style-type: none"> <input type="checkbox"/> F16 - High Plains Depressions (MLRA 72, 73 of LRR H) <input type="checkbox"/> A9 - 1cm Muck (LRR I, J) <input type="checkbox"/> A16 - Coast Prairie Redox (LRR F, G, H) <input type="checkbox"/> S7 - Dark Surface (LRR G) <input type="checkbox"/> F16 - High Plains Depressions (LRR H outside MLRA 72, 73) <input type="checkbox"/> F18 - Reduced Vertic <input type="checkbox"/> TF2 - Red Parent Material <input type="checkbox"/> TF12 - Very Shallow Dark Surface <input type="checkbox"/> Other (Explain in Remarks)
--	--	---

¹ Indicators of hydrophytic vegetation and wetland hydrology must be present, unless disturbed or problematic.

Restrictive Layer (If Observed)	Type: N/A	Depth: N/A	Hydric Soil Present? <input type="checkbox"/> Yes <input checked="" type="checkbox"/> No
---------------------------------	------------------	-------------------	---

Remarks: **The only applicable hydric soil indicator beyond 12" is "Thick Dark Surface (A12)," for which this sample point does not meet the requirements.**

Project/Site: **Harmony Solar Array** Wetland ID: **N/A** Sample Point **U1**
VEGETATION (Species identified in all uppercase are non-native species.)

Tree Stratum (Plot size: 30 ft radius)				
	Species Name	% Cover	Dominant	Ind. Status
1.	--	--	--	--
2.	--	--	--	--
3.	--	--	--	--
4.	--	--	--	--
5.	--	--	--	--
6.	--	--	--	--
7.	--	--	--	--
8.	--	--	--	--
9.	--	--	--	--
10.	--	--	--	--
Total Cover =		0		

Dominance Test Worksheet	
Number of Dominant Species that are OBL, FACW, or FAC:	<u>0</u> (A)
Total Number of Dominant Species Across All Strata:	<u>1</u> (B)
Percent of Dominant Species That Are OBL, FACW, or FAC:	<u>0.0%</u> (A/B)

Sapling/Shrub Stratum (Plot size: 15 ft radius)				
	Species Name	% Cover	Dominant	Ind. Status
1.	--	--	--	--
2.	--	--	--	--
3.	--	--	--	--
4.	--	--	--	--
5.	--	--	--	--
6.	--	--	--	--
7.	--	--	--	--
8.	--	--	--	--
9.	--	--	--	--
10.	--	--	--	--
Total Cover =		0		

Prevalence Index Worksheet	
Total % Cover of:	Multiply by:
OBL spp. <u>0</u>	x 1 = <u>0</u>
FACW spp. <u>0</u>	x 2 = <u>0</u>
FAC spp. <u>0</u>	x 3 = <u>0</u>
FACU spp. <u>0</u>	x 4 = <u>0</u>
UPL spp. <u>5</u>	x 5 = <u>25</u>
Total <u>5</u> (A)	<u>25</u> (B)
Prevalence Index = B/A = <u>5.000</u>	

Herb Stratum (Plot size: 5 ft radius)				
	Species Name	% Cover	Dominant	Ind. Status
1.	GLYCINE MAX	5	Y	UPL
2.	--	--	--	--
3.	--	--	--	--
4.	--	--	--	--
5.	--	--	--	--
6.	--	--	--	--
7.	--	--	--	--
8.	--	--	--	--
9.	--	--	--	--
10.	--	--	--	--
11.	--	--	--	--
12.	--	--	--	--
13.	--	--	--	--
14.	--	--	--	--
15.	--	--	--	--
Total Cover =		5		

Hydrophytic Vegetation Indicators:		
<input type="checkbox"/> Yes	<input checked="" type="checkbox"/> No	Rapid Test for Hydrophytic Vegetation
<input type="checkbox"/> Yes	<input checked="" type="checkbox"/> No	Dominance Test is > 50%
<input type="checkbox"/> Yes	<input checked="" type="checkbox"/> No	Prevalence Index is ≤ 3.0 *
<input type="checkbox"/> Yes	<input type="checkbox"/> No	Morphological Adaptations (Explain) *
<input type="checkbox"/> Yes	<input type="checkbox"/> No	Problem Hydrophytic Vegetation (Explain) *

* Indicators of hydric soil and wetland hydrology must be present, unless disturbed or problematic.

Woody Vine Stratum (Plot size: 30 ft radius)				
	Species Name	% Cover	Dominant	Ind. Status
1.	--	--	--	--
2.	--	--	--	--
3.	--	--	--	--
4.	--	--	--	--
5.	--	--	--	--
Total Cover =		0		

Definitions of Vegetation Strata:	
Tree	- Woody plants 3 in. (7.6cm) or more in diameter at breast height (DBH), regardless of height.
Sapling/Shrub	- Woody plants less than 3 in. DBH and greater than 3.28 ft. tall.
Herb	- All herbaceous (non-woody) plants, regardless of size, and woody plants less than 3.28 ft. tall.
Woody Vines	- All woody vines greater than 3.28 ft. in height.

 Remarks: **Agricultural soybean commodity successfully harvested.**

Hydrophytic Vegetation Present	<input type="checkbox"/> Yes	<input checked="" type="checkbox"/> No
---------------------------------------	------------------------------	--

Additional Remarks:

Sample point located in the lowest local topographic relief of a feature identified as a riverine NWI. The feature is a minor swale through a successfully cropped field, lacking hydrophytic, hydrologic, and hydric soil indicators. The sample point is not a wetland feature.

Project/Site: Harmony Solar Array		Stantec Project #: 193704812	Date: 10/20/16
Applicant: Harmony Solar ND LLC			County: Cass
Investigator #1: Joseph Sander		Investigator #2:	State: North Dakota
Soil Unit: I482A Overly Bearden silt loams	NWI Classification: R4SBC	Local Relief: Concave	Wetland ID: N/A
Landform: Flats	Latitude: --	Longitude: --	Sample Point: U2
Slope (%): 0-2	Datum: NAD 83		Community ID: Agricultural commodity
Are climatic/hydrologic conditions on the site typical for this time of year? (If no, explain in remarks) <input checked="" type="checkbox"/> Yes <input type="checkbox"/> No			Section: 16
Are Vegetation <input checked="" type="checkbox"/> , Soil <input checked="" type="checkbox"/> , or Hydrology <input checked="" type="checkbox"/> significantly disturbed?		Are normal circumstances present? <input type="checkbox"/> Yes <input checked="" type="checkbox"/> No	
Are Vegetation <input type="checkbox"/> , Soil <input type="checkbox"/> , or Hydrology <input type="checkbox"/> naturally problematic? <input type="checkbox"/> Yes <input checked="" type="checkbox"/> No		Township: 140N	
		Range: \$1W Dir: --	

SUMMARY OF FINDINGS

Hydrophytic Vegetation Present? <input type="checkbox"/> Yes <input checked="" type="checkbox"/> No	Hydric Soils Present? <input type="checkbox"/> Yes <input checked="" type="checkbox"/> No
Wetland Hydrology Present? <input type="checkbox"/> Yes <input checked="" type="checkbox"/> No	Is This Sampling Point Within A Wetland? <input checked="" type="checkbox"/> Yes <input type="checkbox"/> No

Remarks: **Sample point is located in a successfully cropped area of an agricultural field subjected to frequent tilling.**

HYDROLOGY

Wetland Hydrology Indicators (Check here if indicators are not present):

<p><u>Primary:</u></p> <ul style="list-style-type: none"> <input type="checkbox"/> A1 - Surface Water <input type="checkbox"/> A2 - High Water Table <input type="checkbox"/> A3 - Saturation <input type="checkbox"/> B1 - Water Marks <input type="checkbox"/> B2 - Sediment Deposits <input type="checkbox"/> B3 - Drift Deposits <input type="checkbox"/> B4 - Algal Mat or Crust <input type="checkbox"/> B5 - Iron Deposits <input type="checkbox"/> B7 - Inundation Visible on Aerial Imagery <input type="checkbox"/> B9 - Water Stained Leaves 	<ul style="list-style-type: none"> <input type="checkbox"/> B11 - Salt Crust <input type="checkbox"/> B13 - Aquatic Invertebrates <input type="checkbox"/> C1 - Hydrogen Sulfide Odor <input type="checkbox"/> C2 - Dry-Season Water Table <input type="checkbox"/> C3 - Oxidized Rhizospheres on Living Roots (where not tilled) <input type="checkbox"/> C4 - Presence of Reduced Iron <input type="checkbox"/> C7 - Thin Muck Surface <input type="checkbox"/> Other (Explain in Remarks) 	<p><u>Secondary:</u></p> <ul style="list-style-type: none"> <input type="checkbox"/> B6 - Surface Soil Cracks <input type="checkbox"/> B8 - Sparsely Vegetated Concave Surface <input type="checkbox"/> B10 - Drainage Patterns <input type="checkbox"/> C3 - Oxidized Rhizospheres on Living Roots (where tilled) <input type="checkbox"/> C8 - Crayfish Burrows <input type="checkbox"/> C9 - Saturation Visible on Aerial Imagery <input checked="" type="checkbox"/> D2 - Geomorphic Position <input type="checkbox"/> D5 - FAC-Neutral Test <input type="checkbox"/> D7 - Frost-Heave Hummocks (LRR F)
---	--	--

Field Observations:

Surface Water Present? <input type="checkbox"/> Yes <input checked="" type="checkbox"/> No	Depth: 0 (in.)	Wetland Hydrology Present? <input type="checkbox"/> Yes <input checked="" type="checkbox"/> No
Water Table Present? <input type="checkbox"/> Yes <input checked="" type="checkbox"/> No	Depth: >24 (in.)	
Saturation Present? <input type="checkbox"/> Yes <input checked="" type="checkbox"/> No	Depth: >24 (in.)	

Describe Recorded Data (stream gauge, monitoring well, aerial photos, previous inspections), if available: **N/A**

Remarks: **Sample point is within a minor swale (4 ft wide) with 1% slope differentiation from topographical surroundings**

SOILS

Map Unit Name: **I482A Overly Bearden silt loams** Series Drainage Class: **Moderately Well Drained**

Taxonomy (Subgroup):

Profile Description (Describe to the depth needed to document the indicator or confirm the absence of indicators.) (Type: C=Concentration, D=Depletion, RM=Reduced Matrix, CS=Covered/Coated Sand Grains, Location: PL=Pore Lining, M=Matrix)

Top Depth	Bottom Depth	Horizon	Matrix			Redox Features				Texture (e.g. clay, sand, loam)	
			Color (Moist)	%		Color (Moist)	%	Type	Location		
0	8	Ap	10YR	2/1	100	--	None	--	--	--	silt loam
8	24	A	10YR	2/1	100	--	None	--	--	--	silt loam
--	--	--	--	--	--	--	--	--	--	--	--
--	--	--	--	--	--	--	--	--	--	--	--
--	--	--	--	--	--	--	--	--	--	--	--
--	--	--	--	--	--	--	--	--	--	--	--
--	--	--	--	--	--	--	--	--	--	--	--

NRCS Hydric Soil Field Indicators (check here if indicators are not present):

<ul style="list-style-type: none"> <input type="checkbox"/> A1 - Histosol <input type="checkbox"/> A2 - Histic Epipedon <input type="checkbox"/> A3 - Black Histic <input type="checkbox"/> A4 - Hydrogen Sulfide <input type="checkbox"/> A5 - Stratified Layers (LRR F) <input type="checkbox"/> A9 - 1 cm Muck (LRR F, G, H) <input type="checkbox"/> A11 - Depleted Below Dark Surface <input type="checkbox"/> A12 - Thick Dark Surface <input type="checkbox"/> S1 - Sandy Muck Mineral <input type="checkbox"/> S2 - 2.5 cm Mucky Peat or Peat (LRR G, H) 	<ul style="list-style-type: none"> <input type="checkbox"/> S3 - 5cm Mucky Peat or Peat (LRR F) <input type="checkbox"/> S4 - Sandy Gleyed Matrix <input type="checkbox"/> S5 - Sandy Redox <input type="checkbox"/> S6 - Stripped Matrix <input type="checkbox"/> F1 - Loamy Mucky Mineral <input type="checkbox"/> F2 Loamy Gleyed Matrix <input type="checkbox"/> F3 - Depleted Matrix <input type="checkbox"/> F6 - Redox Dark Surface <input type="checkbox"/> F7 - Depleted Dark Surface <input type="checkbox"/> F8 - Redox Depressions 	<ul style="list-style-type: none"> <input type="checkbox"/> F16 - High Plains Depressions (MLRA 72, 73 of LRR H) <input type="checkbox"/> A9 - 1cm Muck (LRR I, J) <input type="checkbox"/> A16 - Coast Prairie Redox (LRR F, G, H) <input type="checkbox"/> S7 - Dark Surface (LRR G) <input type="checkbox"/> F16 - High Plains Depressions (LRR H outside MLRA 72, 73) <input type="checkbox"/> F18 - Reduced Vertic <input type="checkbox"/> TF2 - Red Parent Material <input type="checkbox"/> TF12 - Very Shallow Dark Surface <input type="checkbox"/> Other (Explain in Remarks)
--	--	---

¹ Indicators of hydrophytic vegetation and wetland hydrology must be present, unless disturbed or problematic.

Restrictive Layer (If Observed) Type: **N/A** Depth: **N/A** **Hydric Soil Present?** Yes No

Remarks: **The only applicable hydric soil indicator beyond 12" is "Thick Dark Surface (A12)," for which this sample point does not meet the requirements.**

Project/Site: **Harmony Solar Array** Wetland ID: **N/A** Sample Point **U2**
VEGETATION (Species identified in all uppercase are non-native species.)

Tree Stratum (Plot size: 30 ft radius)				
	Species Name	% Cover	Dominant	Ind. Status
1.	--	--	--	--
2.	--	--	--	--
3.	--	--	--	--
4.	--	--	--	--
5.	--	--	--	--
6.	--	--	--	--
7.	--	--	--	--
8.	--	--	--	--
9.	--	--	--	--
10.	--	--	--	--
Total Cover =		0		

Dominance Test Worksheet

 Number of Dominant Species that are OBL, FACW, or FAC: 0 (A)
 Total Number of Dominant Species Across All Strata: 1 (B)
 Percent of Dominant Species That Are OBL, FACW, or FAC: 0.0% (A/B)

Prevalence Index Worksheet

Total % Cover of:		Multiply by:	
OBL spp.	<u>0</u>	x 1 =	<u>0</u>
FACW spp.	<u>0</u>	x 2 =	<u>0</u>
FAC spp.	<u>0</u>	x 3 =	<u>0</u>
FACU spp.	<u>0</u>	x 4 =	<u>0</u>
UPL spp.	<u>5</u>	x 5 =	<u>25</u>
Total		<u>5</u> (A)	<u>25</u> (B)
Prevalence Index = B/A =		<u>5.000</u>	

Sapling/Shrub Stratum (Plot size: 15 ft radius)				
	Species Name	% Cover	Dominant	Ind. Status
1.	--	--	--	--
2.	--	--	--	--
3.	--	--	--	--
4.	--	--	--	--
5.	--	--	--	--
6.	--	--	--	--
7.	--	--	--	--
8.	--	--	--	--
9.	--	--	--	--
10.	--	--	--	--
Total Cover =		0		

Hydrophytic Vegetation Indicators:

- | | | |
|------------------------------|--|--|
| <input type="checkbox"/> Yes | <input checked="" type="checkbox"/> No | Rapid Test for Hydrophytic Vegetation |
| <input type="checkbox"/> Yes | <input checked="" type="checkbox"/> No | Dominance Test is > 50% |
| <input type="checkbox"/> Yes | <input checked="" type="checkbox"/> No | Prevalence Index is ≤ 3.0 * |
| <input type="checkbox"/> Yes | <input type="checkbox"/> No | Morphological Adaptations (Explain) * |
| <input type="checkbox"/> Yes | <input type="checkbox"/> No | Problem Hydrophytic Vegetation (Explain) * |

* Indicators of hydric soil and wetland hydrology must be present, unless disturbed or problematic.

Herb Stratum (Plot size: 5 ft radius)				
	Species Name	% Cover	Dominant	Ind. Status
1.	GLYCINE MAX	5	Y	UPL
2.	--	--	--	--
3.	--	--	--	--
4.	--	--	--	--
5.	--	--	--	--
6.	--	--	--	--
7.	--	--	--	--
8.	--	--	--	--
9.	--	--	--	--
10.	--	--	--	--
11.	--	--	--	--
12.	--	--	--	--
13.	--	--	--	--
14.	--	--	--	--
15.	--	--	--	--
Total Cover =		5		

Definitions of Vegetation Strata:

- Tree** - Woody plants 3 in. (7.6cm) or more in diameter at breast height (DBH), regardless of height.
- Sapling/Shrub** - Woody plants less than 3 in. DBH and greater than 3.28 ft. tall.
- Herb** - All herbaceous (non-woody) plants, regardless of size, and woody plants less than 3.28 ft. tall.
- Woody Vines** - All woody vines greater than 3.28 ft. in height.

Woody Vine Stratum (Plot size: 30 ft radius)				
	Species Name	% Cover	Dominant	Ind. Status
1.	--	--	--	--
2.	--	--	--	--
3.	--	--	--	--
4.	--	--	--	--
5.	--	--	--	--
Total Cover =		0		

Hydrophytic Vegetation Present Yes No

 Remarks: **Agricultural soybean commodity successfully harvested.**
Additional Remarks:

Sample point located in the lowest local topographic relief of a feature identified as a riverine NWI. The feature is a minor swale through a successfully cropped field, lacking hydrophytic, hydrologic, and hydric soil indicators. The sample point is not a wetland feature.

Project/Site: Harmony Solar Array		Stantec Project #: 193704812	Date: 10/20/16
Applicant: Harmony Solar ND LLC			County: Cass
Investigator #1: Joseph Sander		Investigator #2:	State: North Dakota
Soil Unit: I482A Overly Bearden silt loams	NWI Classification: R4SBC	Wetland ID: N/A	Sample Point: U3
Landform: Flats	Local Relief: Concave	Community ID: Agricultural commodity	Section: 16
Slope (%): 0-2	Latitude: --	Longitude: --	Datum: NAD 83
Are climatic/hydrologic conditions on the site typical for this time of year? (If no, explain in remarks) <input checked="" type="checkbox"/> Yes <input type="checkbox"/> No			Township: 140N
Are Vegetation <input checked="" type="checkbox"/> , Soil <input checked="" type="checkbox"/> , or Hydrology <input checked="" type="checkbox"/> significantly disturbed?		Are normal circumstances present? <input type="checkbox"/> Yes <input checked="" type="checkbox"/> No	
Are Vegetation <input type="checkbox"/> , Soil <input type="checkbox"/> , or Hydrology <input type="checkbox"/> naturally problematic?		<input type="checkbox"/> Yes <input checked="" type="checkbox"/> No	
Remarks: Sample point is located in a successfully cropped area of an agricultural field subjected to frequent tilling.		Range: \$1W Dir: --	

SUMMARY OF FINDINGS

Hydrophytic Vegetation Present? <input type="checkbox"/> Yes <input checked="" type="checkbox"/> No	Hydric Soils Present? <input type="checkbox"/> Yes <input checked="" type="checkbox"/> No
Wetland Hydrology Present? <input type="checkbox"/> Yes <input checked="" type="checkbox"/> No	Is This Sampling Point Within A Wetland? <input checked="" type="checkbox"/> Yes <input type="checkbox"/> No

HYDROLOGY

Wetland Hydrology Indicators (Check here if indicators are not present):

<p><u>Primary:</u></p> <ul style="list-style-type: none"> <input type="checkbox"/> A1 - Surface Water <input type="checkbox"/> A2 - High Water Table <input type="checkbox"/> A3 - Saturation <input type="checkbox"/> B1 - Water Marks <input type="checkbox"/> B2 - Sediment Deposits <input type="checkbox"/> B3 - Drift Deposits <input type="checkbox"/> B4 - Algal Mat or Crust <input type="checkbox"/> B5 - Iron Deposits <input type="checkbox"/> B7 - Inundation Visible on Aerial Imagery <input type="checkbox"/> B9 - Water Stained Leaves 	<ul style="list-style-type: none"> <input checked="" type="checkbox"/> B11 - Salt Crust <input type="checkbox"/> B13 - Aquatic Invertebrates <input type="checkbox"/> C1 - Hydrogen Sulfide Odor <input type="checkbox"/> C2 - Dry-Season Water Table <input type="checkbox"/> C3 - Oxidized Rhizospheres on Living Roots (where not tilled) <input type="checkbox"/> C4 - Presence of Reduced Iron <input type="checkbox"/> C7 - Thin Muck Surface <input type="checkbox"/> Other (Explain in Remarks) 	<p><u>Secondary:</u></p> <ul style="list-style-type: none"> <input checked="" type="checkbox"/> B6 - Surface Soil Cracks <input type="checkbox"/> B8 - Sparsely Vegetated Concave Surface <input type="checkbox"/> B10 - Drainage Patterns <input type="checkbox"/> C3 - Oxidized Rhizospheres on Living Roots (where tilled) <input type="checkbox"/> C8 - Crayfish Burrows <input type="checkbox"/> C9 - Saturation Visible on Aerial Imagery <input checked="" type="checkbox"/> D2 - Geomorphic Position <input type="checkbox"/> D5 - FAC-Neutral Test <input type="checkbox"/> D7 - Frost-Heave Hummocks (LRR F)
---	---	---

Field Observations:

Surface Water Present? <input type="checkbox"/> Yes <input checked="" type="checkbox"/> No	Depth: 0 (in.)	Wetland Hydrology Present? <input type="checkbox"/> Yes <input checked="" type="checkbox"/> No
Water Table Present? <input type="checkbox"/> Yes <input checked="" type="checkbox"/> No	Depth: >24 (in.)	
Saturation Present? <input type="checkbox"/> Yes <input checked="" type="checkbox"/> No	Depth: >24 (in.)	

Describe Recorded Data (stream gauge, monitoring well, aerial photos, previous inspections), if available: **N/A**

Remarks: **Sample point is within a minor swale (4 ft wide) with 1% slope differentiation from topographical surroundings. Water may pond and evaporate from this location but does not hold water for significant periods of time.**

SOILS

Map Unit Name: **I482A Overly Bearden silt loams** Series Drainage Class: **Moderately Well Drained**

Taxonomy (Subgroup):

Profile Description (Describe to the depth needed to document the indicator or confirm the absence of indicators.) (Type: C=Concentration, D=Depletion, RM=Reduced Matrix, CS=Covered/Coated Sand Grains, Location: PL=Pore Lining, M=Matrix)

Top Depth	Bottom Depth	Horizon	Matrix			Redox Features				Texture (e.g. clay, sand, loam)	
			Color (Moist)	%		Color (Moist)	%	Type	Location		
0	1	Ap	10YR	6/4	100	--	None	--	--	--	silt loam
1	8	Ap	10YR	4/4	100	--	None	--	--	--	silt loam
8	18	A	10YR	4/4	100	--	None	--	--	--	silt loam
18	24	A	10YR	4/3	100	--	None	--	--	--	silt loam
--	--	--	--	--	--	--	--	--	--	--	--
--	--	--	--	--	--	--	--	--	--	--	--
--	--	--	--	--	--	--	--	--	--	--	--
--	--	--	--	--	--	--	--	--	--	--	--

NRCS Hydric Soil Field Indicators (check here if indicators are not present):

<ul style="list-style-type: none"> <input type="checkbox"/> A1 - Histosol <input type="checkbox"/> A2 - Histic Epipedon <input type="checkbox"/> A3 - Black Histic <input type="checkbox"/> A4 - Hydrogen Sulfide <input type="checkbox"/> A5 - Stratified Layers (LRR F) <input type="checkbox"/> A9 - 1 cm Muck (LRR F, G, H) <input type="checkbox"/> A11 - Depleted Below Dark Surface <input type="checkbox"/> A12 - Thick Dark Surface <input type="checkbox"/> S1 - Sandy Muck Mineral <input type="checkbox"/> S2 - 2.5 cm Mucky Peat or Peat (LRR G, H) 	<ul style="list-style-type: none"> <input type="checkbox"/> S3 - 5cm Mucky Peat or Peat (LRR F) <input type="checkbox"/> S4 - Sandy Gleyed Matrix <input type="checkbox"/> S5 - Sandy Redox <input type="checkbox"/> S6 - Stripped Matrix <input type="checkbox"/> F1 - Loamy Mucky Mineral <input type="checkbox"/> F2 Loamy Gleyed Matrix <input type="checkbox"/> F3 - Depleted Matrix <input type="checkbox"/> F6 - Redox Dark Surface <input type="checkbox"/> F7 - Depleted Dark Surface <input type="checkbox"/> F8 - Redox Depressions 	<ul style="list-style-type: none"> <input type="checkbox"/> F16 - High Plains Depressions (MLRA 72, 73 of LRR H) <input type="checkbox"/> A9 - 1cm Muck (LRR I, J) <input type="checkbox"/> A16 - Coast Prairie Redox (LRR F, G, H) <input type="checkbox"/> S7 - Dark Surface (LRR G) <input type="checkbox"/> F16 - High Plains Depressions (LRR H outside MLRA 72, 73) <input type="checkbox"/> F18 - Reduced Vertic <input type="checkbox"/> TF2 - Red Parent Material <input type="checkbox"/> TF12 - Very Shallow Dark Surface <input type="checkbox"/> Other (Explain in Remarks)
--	--	---

¹ Indicators of hydrophytic vegetation and wetland hydrology must be present, unless disturbed or problematic.

Restrictive Layer (If Observed) Type: N/A Depth: N/A	Hydric Soil Present? <input type="checkbox"/> Yes <input checked="" type="checkbox"/> No
--	---

Remarks: **The only applicable hydric soil indicator beyond 12" is "Thick Dark Surface (A12)," for which this sample point does not meet the requirements.**

Project/Site: **Harmony Solar Array** Wetland ID: **N/A** Sample Point **U3**
VEGETATION (Species identified in all uppercase are non-native species.)

Tree Stratum (Plot size: 30 ft radius)				
	Species Name	% Cover	Dominant	Ind. Status
1.	--	--	--	--
2.	--	--	--	--
3.	--	--	--	--
4.	--	--	--	--
5.	--	--	--	--
6.	--	--	--	--
7.	--	--	--	--
8.	--	--	--	--
9.	--	--	--	--
10.	--	--	--	--
Total Cover =		0		

Dominance Test Worksheet	
Number of Dominant Species that are OBL, FACW, or FAC:	<u>0</u> (A)
Total Number of Dominant Species Across All Strata:	<u>1</u> (B)
Percent of Dominant Species That Are OBL, FACW, or FAC:	<u>0.0%</u> (A/B)

Sapling/Shrub Stratum (Plot size: 15 ft radius)				
	Species Name	% Cover	Dominant	Ind. Status
1.	--	--	--	--
2.	--	--	--	--
3.	--	--	--	--
4.	--	--	--	--
5.	--	--	--	--
6.	--	--	--	--
7.	--	--	--	--
8.	--	--	--	--
9.	--	--	--	--
10.	--	--	--	--
Total Cover =		0		

Prevalence Index Worksheet	
Total % Cover of:	Multiply by:
OBL spp. <u>0</u>	x 1 = <u>0</u>
FACW spp. <u>0</u>	x 2 = <u>0</u>
FAC spp. <u>0</u>	x 3 = <u>0</u>
FACU spp. <u>0</u>	x 4 = <u>0</u>
UPL spp. <u>5</u>	x 5 = <u>25</u>
Total <u>5</u> (A)	<u>25</u> (B)
Prevalence Index = B/A = <u>5.000</u>	

Herb Stratum (Plot size: 5 ft radius)				
	Species Name	% Cover	Dominant	Ind. Status
1.	GLYCINE MAX	5	Y	UPL
2.	--	--	--	--
3.	--	--	--	--
4.	--	--	--	--
5.	--	--	--	--
6.	--	--	--	--
7.	--	--	--	--
8.	--	--	--	--
9.	--	--	--	--
10.	--	--	--	--
11.	--	--	--	--
12.	--	--	--	--
13.	--	--	--	--
14.	--	--	--	--
15.	--	--	--	--
Total Cover =		5		

Hydrophytic Vegetation Indicators:		
<input type="checkbox"/> Yes	<input checked="" type="checkbox"/> No	Rapid Test for Hydrophytic Vegetation
<input type="checkbox"/> Yes	<input checked="" type="checkbox"/> No	Dominance Test is > 50%
<input type="checkbox"/> Yes	<input checked="" type="checkbox"/> No	Prevalence Index is ≤ 3.0 *
<input type="checkbox"/> Yes	<input type="checkbox"/> No	Morphological Adaptations (Explain) *
<input type="checkbox"/> Yes	<input type="checkbox"/> No	Problem Hydrophytic Vegetation (Explain) *

* Indicators of hydric soil and wetland hydrology must be present, unless disturbed or problematic.

Woody Vine Stratum (Plot size: 30 ft radius)				
	Species Name	% Cover	Dominant	Ind. Status
1.	--	--	--	--
2.	--	--	--	--
3.	--	--	--	--
4.	--	--	--	--
5.	--	--	--	--
Total Cover =		0		

Definitions of Vegetation Strata:	
Tree	Woody plants 3 in. (7.6cm) or more in diameter at breast height (DBH), regardless of height.
Sapling/Shrub	Woody plants less than 3 in. DBH and greater than 3.28 ft. tall.
Herb	All herbaceous (non-woody) plants, regardless of size, and woody plants less than 3.28 ft. tall.
Woody Vines	All woody vines greater than 3.28 ft. in height.

 Remarks: **Agricultural soybean commodity successfully harvested.**

Hydrophytic Vegetation Present	<input type="checkbox"/> Yes	<input checked="" type="checkbox"/> No
---------------------------------------	------------------------------	--

Additional Remarks:

Sample point located in the lowest local topographic relief of a feature identified as a riverine NWI. The feature is a minor swale through a successfully cropped field, lacking hydrophytic and hydric soil indicators. Apparent salt crusts and surface soil cracks suggest the area ponds water, but does not inundate long enough to produce hydric soils. The sample point is not a wetland feature.

Project/Site: Harmony Solar Array		Stantec Project #: 193704812	Date: 10/20/16
Applicant: Harmony Solar ND LLC			County: Cass
Investigator #1: Joseph Sander		Investigator #2:	State: North Dakota
Soil Unit: I371A Bearden-Kindred silty clay loams	NWI Classification: None	Wetland ID: N/A	Sample Point: U4
Landform: Swailes, Flats	Local Relief: Concave	Community ID: Agricultural commodity	Section: 16
Slope (%): 0-2	Latitude: --	Longitude: --	Datum: NAD 83
Are climatic/hydrologic conditions on the site typical for this time of year? (If no, explain in remarks) <input checked="" type="checkbox"/> Yes <input type="checkbox"/> No		Township: 140N	
Are Vegetation <input checked="" type="checkbox"/> , Soil <input checked="" type="checkbox"/> , or Hydrology <input checked="" type="checkbox"/> significantly disturbed?		Range: \$1W Dir: --	
Are Vegetation <input type="checkbox"/> , Soil <input type="checkbox"/> , or Hydrology <input type="checkbox"/> naturally problematic?		Are normal circumstances present? <input type="checkbox"/> Yes <input checked="" type="checkbox"/> No	

SUMMARY OF FINDINGS

Hydrophytic Vegetation Present? <input type="checkbox"/> Yes <input checked="" type="checkbox"/> No	Hydric Soils Present? <input type="checkbox"/> Yes <input checked="" type="checkbox"/> No
Wetland Hydrology Present? <input type="checkbox"/> Yes <input checked="" type="checkbox"/> No	Is This Sampling Point Within A Wetland? <input checked="" type="checkbox"/> Yes <input type="checkbox"/> No

Remarks: **Sample point is located in a successfully cropped area of an agricultural field subjected to frequent tilling.**

HYDROLOGY

Wetland Hydrology Indicators (Check here if indicators are not present):

<p><u>Primary:</u></p> <ul style="list-style-type: none"> <input type="checkbox"/> A1 - Surface Water <input type="checkbox"/> A2 - High Water Table <input type="checkbox"/> A3 - Saturation <input type="checkbox"/> B1 - Water Marks <input type="checkbox"/> B2 - Sediment Deposits <input type="checkbox"/> B3 - Drift Deposits <input type="checkbox"/> B4 - Algal Mat or Crust <input type="checkbox"/> B5 - Iron Deposits <input type="checkbox"/> B7 - Inundation Visible on Aerial Imagery <input type="checkbox"/> B9 - Water Stained Leaves 	<ul style="list-style-type: none"> <input type="checkbox"/> B11 - Salt Crust <input type="checkbox"/> B13 - Aquatic Invertebrates <input type="checkbox"/> C1 - Hydrogen Sulfide Odor <input type="checkbox"/> C2 - Dry-Season Water Table <input type="checkbox"/> C3 - Oxidized Rhizospheres on Living Roots (where not tilled) <input type="checkbox"/> C4 - Presence of Reduced Iron <input type="checkbox"/> C7 - Thin Muck Surface <input type="checkbox"/> Other (Explain in Remarks) 	<p><u>Secondary:</u></p> <ul style="list-style-type: none"> <input type="checkbox"/> B6 - Surface Soil Cracks <input type="checkbox"/> B8 - Sparsely Vegetated Concave Surface <input type="checkbox"/> B10 - Drainage Patterns <input type="checkbox"/> C3 - Oxidized Rhizospheres on Living Roots (where tilled) <input type="checkbox"/> C8 - Crayfish Burrows <input type="checkbox"/> C9 - Saturation Visible on Aerial Imagery <input checked="" type="checkbox"/> D2 - Geomorphic Position <input type="checkbox"/> D5 - FAC-Neutral Test <input type="checkbox"/> D7 - Frost-Heave Hummocks (LRR F)
---	--	--

Field Observations:

Surface Water Present? <input type="checkbox"/> Yes <input checked="" type="checkbox"/> No	Depth: 0 (in.)	Wetland Hydrology Present? <input type="checkbox"/> Yes <input checked="" type="checkbox"/> No
Water Table Present? <input type="checkbox"/> Yes <input checked="" type="checkbox"/> No	Depth: 0 (in.)	
Saturation Present? <input type="checkbox"/> Yes <input checked="" type="checkbox"/> No	Depth: 0 (in.)	

Describe Recorded Data (stream gauge, monitoring well, aerial photos, previous inspections), if available: **N/A**

Remarks: **Sample point is located near a ditch along a section road with 1% slope differentiation from topographical surroundings**

SOILS

Map Unit Name: **I371A Bearden-Kindred silty clay loams** Series Drainage Class: **Somewhat poorly drained**

Taxonomy (Subgroup):

Profile Description (Describe to the depth needed to document the indicator or confirm the absence of indicators.) (Type: C=Concentration, D=Depletion, RM=Reduced Matrix, CS=Covered/Coated Sand Grains, Location: PL=Pore Lining, M=Matrix)

Top Depth	Bottom Depth	Horizon	Matrix			Redox Features				Texture (e.g. clay, sand, loam)	
			Color (Moist)	%		Color (Moist)	%	Type	Location		
0	8	Ap	10YR	2/1	100	--	None	--	--	--	silty clay loam
8	20	A	10YR	2/1	100	--	None	--	--	--	silty clay loam
20	24	B	2.5Y	5/3	100	--	None	--	--	--	silty clay loam
--	--	--	--	--	--	--	--	--	--	--	--
--	--	--	--	--	--	--	--	--	--	--	--
--	--	--	--	--	--	--	--	--	--	--	--
--	--	--	--	--	--	--	--	--	--	--	--

NRCS Hydric Soil Field Indicators (check here if indicators are not present):

<ul style="list-style-type: none"> <input type="checkbox"/> A1 - Histosol <input type="checkbox"/> A2 - Histic Epipedon <input type="checkbox"/> A3 - Black Histic <input type="checkbox"/> A4 - Hydrogen Sulfide <input type="checkbox"/> A5 - Stratified Layers (LRR F) <input type="checkbox"/> A9 - 1 cm Muck (LRR F, G, H) <input type="checkbox"/> A11 - Depleted Below Dark Surface <input type="checkbox"/> A12 - Thick Dark Surface <input type="checkbox"/> S1 - Sandy Muck Mineral <input type="checkbox"/> S2 - 2.5 cm Mucky Peat or Peat (LRR G, H) 	<ul style="list-style-type: none"> <input type="checkbox"/> S3 - 5cm Mucky Peat or Peat (LRR F) <input type="checkbox"/> S4 - Sandy Gleyed Matrix <input type="checkbox"/> S5 - Sandy Redox <input type="checkbox"/> S6 - Stripped Matrix <input type="checkbox"/> F1 - Loamy Mucky Mineral <input type="checkbox"/> F2 Loamy Gleyed Matrix <input type="checkbox"/> F3 - Depleted Matrix <input type="checkbox"/> F6 - Redox Dark Surface <input type="checkbox"/> F7 - Depleted Dark Surface <input type="checkbox"/> F8 - Redox Depressions 	<ul style="list-style-type: none"> <input type="checkbox"/> F16 - High Plains Depressions (MLRA 72, 73 of LRR H) <input type="checkbox"/> A9 - 1cm Muck (LRR I, J) <input type="checkbox"/> A16 - Coast Prairie Redox (LRR F, G, H) <input type="checkbox"/> S7 - Dark Surface (LRR G) <input type="checkbox"/> F16 - High Plains Depressions (LRR H outside MLRA 72, 73) <input type="checkbox"/> F18 - Reduced Vertic <input type="checkbox"/> TF2 - Red Parent Material <input type="checkbox"/> TF12 - Very Shallow Dark Surface <input type="checkbox"/> Other (Explain in Remarks)
--	--	---

Restrictive Layer (If Observed) Type: **N/A** Depth: **N/A** **Hydric Soil Present?** Yes No

Remarks: **The only applicable hydric soil indicator beyond 12" is "Thick Dark Surface (A12)," for which this sample point does not meet the requirements.**

¹ Indicators of hydrophytic vegetation and wetland hydrology must be present, unless disturbed or problematic.

Project/Site: **Harmony Solar Array** Wetland ID: **N/A** Sample Point **U4**

VEGETATION (Species identified in all uppercase are non-native species.)				
Tree Stratum (Plot size: 30 ft radius)				
	<i>Species Name</i>	% Cover	Dominant	Ind. Status
1.	--	--	--	--
2.	--	--	--	--
3.	--	--	--	--
4.	--	--	--	--
5.	--	--	--	--
6.	--	--	--	--
7.	--	--	--	--
8.	--	--	--	--
9.	--	--	--	--
10.	--	--	--	--
Total Cover =		0		
Sapling/Shrub Stratum (Plot size: 15 ft radius)				
1.	--	--	--	--
2.	--	--	--	--
3.	--	--	--	--
4.	--	--	--	--
5.	--	--	--	--
6.	--	--	--	--
7.	--	--	--	--
8.	--	--	--	--
9.	--	--	--	--
10.	--	--	--	--
Total Cover =		0		
Herb Stratum (Plot size: 5 ft radius)				
1.	TRITICUM spp.	20	Y	UPL
2.	--	--	--	--
3.	--	--	--	--
4.	--	--	--	--
5.	--	--	--	--
6.	--	--	--	--
7.	--	--	--	--
8.	--	--	--	--
9.	--	--	--	--
10.	--	--	--	--
11.	--	--	--	--
12.	--	--	--	--
13.	--	--	--	--
14.	--	--	--	--
15.	--	--	--	--
Total Cover =		20		
Woody Vine Stratum (Plot size: 30 ft radius)				
1.	--	--	--	--
2.	--	--	--	--
3.	--	--	--	--
4.	--	--	--	--
5.	--	--	--	--
Total Cover =		0		
Dominance Test Worksheet				
Number of Dominant Species that are OBL, FACW, or FAC: <u>0</u> (A)				
Total Number of Dominant Species Across All Strata: <u>1</u> (B)				
Percent of Dominant Species That Are OBL, FACW, or FAC: <u>0.0%</u> (A/B)				
Prevalence Index Worksheet				
Total % Cover of:				
OBL spp.	<u>0</u>	x 1 =	<u>0</u>	
FACW spp.	<u>0</u>	x 2 =	<u>0</u>	
FAC spp.	<u>0</u>	x 3 =	<u>0</u>	
FACU spp.	<u>0</u>	x 4 =	<u>0</u>	
UPL spp.	<u>20</u>	x 5 =	<u>100</u>	
Total		<u>20</u> (A)	<u>100</u> (B)	
Prevalence Index = B/A = <u>5.000</u>				
Hydrophytic Vegetation Indicators:				
<input type="checkbox"/> Yes	<input checked="" type="checkbox"/> No	Rapid Test for Hydrophytic Vegetation		
<input type="checkbox"/> Yes	<input checked="" type="checkbox"/> No	Dominance Test is > 50%		
<input type="checkbox"/> Yes	<input checked="" type="checkbox"/> No	Prevalence Index is ≤ 3.0 *		
<input type="checkbox"/> Yes	<input type="checkbox"/> No	Morphological Adaptations (Explain) *		
<input type="checkbox"/> Yes	<input type="checkbox"/> No	Problem Hydrophytic Vegetation (Explain) *		
* Indicators of hydric soil and wetland hydrology must be present, unless disturbed or problematic.				
Definitions of Vegetation Strata:				
Tree - Woody plants 3 in. (7.6cm) or more in diameter at breast height (DBH), regardless of height.				
Sapling/Shrub - Woody plants less than 3 in. DBH and greater than 3.28 ft. tall.				
Herb - All herbaceous (non-woody) plants, regardless of size, and woody plants less than 3.28 ft. tall.				
Woody Vines - All woody vines greater than 3.28 ft. in height.				
Hydrophytic Vegetation Present <input type="checkbox"/> Yes <input checked="" type="checkbox"/> No				
Remarks: Agricultural wheat commodity successfully harvested.				

Additional Remarks:

Sample point located in the lowest local topographic relief of a wet signature identified from FSA slides. The sample point is in a successfully cropped field, lacking hydrophytic, hydrologic, and hydric soil indicators. The sample point is not a wetland feature.

Project/Site: Harmony Solar Array		Stantec Project #: 193704812	Date: 10/20/16
Applicant: Harmony Solar ND LLC			County: Cass
Investigator #1: Joseph Sander		Investigator #2:	State: North Dakota
Soil Unit: I371A Bearden-Kindred silty clay loams	NWI Classification: None	Wetland ID: N/A	Sample Point: U5
Landform: Swailes, Flats	Local Relief: None	Community ID: Agricultural commodity	Section: 16
Slope (%): 0-2	Latitude: --	Longitude: --	Datum: NAD 83
Are climatic/hydrologic conditions on the site typical for this time of year? (If no, explain in remarks) <input checked="" type="checkbox"/> Yes <input type="checkbox"/> No		Are normal circumstances present? <input type="checkbox"/> Yes <input checked="" type="checkbox"/> No	
Are Vegetation <input checked="" type="checkbox"/> , Soil <input checked="" type="checkbox"/> , or Hydrology <input checked="" type="checkbox"/> significantly disturbed?		Are Vegetation <input type="checkbox"/> , Soil <input type="checkbox"/> , or Hydrology <input type="checkbox"/> naturally problematic? <input type="checkbox"/> Yes <input checked="" type="checkbox"/> No	
Township: 140N		Range: 51W Dir: --	

SUMMARY OF FINDINGS

Hydrophytic Vegetation Present? <input type="checkbox"/> Yes <input checked="" type="checkbox"/> No	Hydric Soils Present? <input type="checkbox"/> Yes <input checked="" type="checkbox"/> No
Wetland Hydrology Present? <input type="checkbox"/> Yes <input checked="" type="checkbox"/> No	Is This Sampling Point Within A Wetland? <input checked="" type="checkbox"/> Yes <input type="checkbox"/> No

Remarks: **Sample point is located in a successfully cropped area of an agricultural field subjected to frequent tilling.**

HYDROLOGY

Wetland Hydrology Indicators (Check here if indicators are not present):

<p><u>Primary:</u></p> <ul style="list-style-type: none"> <input type="checkbox"/> A1 - Surface Water <input type="checkbox"/> A2 - High Water Table <input type="checkbox"/> A3 - Saturation <input type="checkbox"/> B1 - Water Marks <input type="checkbox"/> B2 - Sediment Deposits <input type="checkbox"/> B3 - Drift Deposits <input type="checkbox"/> B4 - Algal Mat or Crust <input type="checkbox"/> B5 - Iron Deposits <input type="checkbox"/> B7 - Inundation Visible on Aerial Imagery <input type="checkbox"/> B9 - Water Stained Leaves 	<ul style="list-style-type: none"> <input type="checkbox"/> B11 - Salt Crust <input type="checkbox"/> B13 - Aquatic Invertebrates <input type="checkbox"/> C1 - Hydrogen Sulfide Odor <input type="checkbox"/> C2 - Dry-Season Water Table <input type="checkbox"/> C3 - Oxidized Rhizospheres on Living Roots (where not tilled) <input type="checkbox"/> C4 - Presence of Reduced Iron <input type="checkbox"/> C7 - Thin Muck Surface <input type="checkbox"/> Other (Explain in Remarks) 	<p><u>Secondary:</u></p> <ul style="list-style-type: none"> <input type="checkbox"/> B6 - Surface Soil Cracks <input type="checkbox"/> B8 - Sparsely Vegetated Concave Surface <input type="checkbox"/> B10 - Drainage Patterns <input type="checkbox"/> C3 - Oxidized Rhizospheres on Living Roots (where tilled) <input type="checkbox"/> C8 - Crayfish Burrows <input type="checkbox"/> C9 - Saturation Visible on Aerial Imagery <input type="checkbox"/> D2 - Geomorphic Position <input type="checkbox"/> D5 - FAC-Neutral Test <input type="checkbox"/> D7 - Frost-Heave Hummocks (LRR F)
---	--	---

Field Observations:

Surface Water Present? <input type="checkbox"/> Yes <input checked="" type="checkbox"/> No	Depth: 0 (in.)	Wetland Hydrology Present? <input type="checkbox"/> Yes <input checked="" type="checkbox"/> No
Water Table Present? <input type="checkbox"/> Yes <input checked="" type="checkbox"/> No	Depth: >24 (in.)	
Saturation Present? <input type="checkbox"/> Yes <input checked="" type="checkbox"/> No	Depth: >24 (in.)	

Describe Recorded Data (stream gauge, monitoring well, aerial photos, previous inspections), if available: **N/A**

Remarks: **Sample point is located in a flat area without discernable slope differentiation from topographical surroundings.**

SOILS

Map Unit Name: **I371A Bearden-Kindred silty clay loams** Series Drainage Class: **Somewhat poorly drained**

Taxonomy (Subgroup):

Profile Description (Describe to the depth needed to document the indicator or confirm the absence of indicators.) (Type: C=Concentration, D=Depletion, RM=Reduced Matrix, CS=Covered/Coated Sand Grains, Location: PL=Pore Lining, M=Matrix)

Top Depth	Bottom Depth	Horizon	Matrix			Redox Features				Texture (e.g. clay, sand, loam)	
			Color (Moist)	%		Color (Moist)	%	Type	Location		
0	8	Ap	10YR	2/1	100	--	None	--	--	--	silty clay loam
8	16	A	10YR	2/1	100	--	None	--	--	--	silty clay loam
16	24	B	2.5Y	5/3	100	--	None	--	--	--	silty clay loam
--	--	--	--	--	--	--	--	--	--	--	--
--	--	--	--	--	--	--	--	--	--	--	--
--	--	--	--	--	--	--	--	--	--	--	--
--	--	--	--	--	--	--	--	--	--	--	--

NRCS Hydric Soil Field Indicators (check here if indicators are not present):

<ul style="list-style-type: none"> <input type="checkbox"/> A1 - Histosol <input type="checkbox"/> A2 - Histic Epipedon <input type="checkbox"/> A3 - Black Histic <input type="checkbox"/> A4 - Hydrogen Sulfide <input type="checkbox"/> A5 - Stratified Layers (LRR F) <input type="checkbox"/> A9 - 1 cm Muck (LRR F, G, H) <input type="checkbox"/> A11 - Depleted Below Dark Surface <input type="checkbox"/> A12 - Thick Dark Surface <input type="checkbox"/> S1 - Sandy Muck Mineral <input type="checkbox"/> S2 - 2.5 cm Mucky Peat or Peat (LRR G, H) 	<ul style="list-style-type: none"> <input type="checkbox"/> S3 - 5cm Mucky Peat or Peat (LRR F) <input type="checkbox"/> S4 - Sandy Gleyed Matrix <input type="checkbox"/> S5 - Sandy Redox <input type="checkbox"/> S6 - Stripped Matrix <input type="checkbox"/> F1 - Loamy Mucky Mineral <input type="checkbox"/> F2 Loamy Gleyed Matrix <input type="checkbox"/> F3 - Depleted Matrix <input type="checkbox"/> F6 - Redox Dark Surface <input type="checkbox"/> F7 - Depleted Dark Surface <input type="checkbox"/> F8 - Redox Depressions 	<ul style="list-style-type: none"> <input type="checkbox"/> F16 - High Plains Depressions (MLRA 72, 73 of LRR H) <input type="checkbox"/> A9 - 1cm Muck (LRR I, J) <input type="checkbox"/> A16 - Coast Prairie Redox (LRR F, G, H) <input type="checkbox"/> S7 - Dark Surface (LRR G) <input type="checkbox"/> F16 - High Plains Depressions (LRR H outside MLRA 72, 73) <input type="checkbox"/> F18 - Reduced Vertic <input type="checkbox"/> TF2 - Red Parent Material <input type="checkbox"/> TF12 - Very Shallow Dark Surface <input type="checkbox"/> Other (Explain in Remarks)
--	--	---

Restrictive Layer (If Observed) Type: **N/A** Depth: **N/A** **Hydric Soil Present?** Yes No

Remarks: **The only applicable hydric soil indicator beyond 12" is "Thick Dark Surface (A12)," for which this sample point does not meet the requirements.**

¹ Indicators of hydrophytic vegetation and wetland hydrology must be present, unless disturbed or problematic.

Project/Site: **Harmony Solar Array** Wetland ID: **N/A** Sample Point **U5**
VEGETATION (Species identified in all uppercase are non-native species.)

Tree Stratum (Plot size: 30 ft radius)					Dominance Test Worksheet Number of Dominant Species that are OBL, FACW, or FAC: <u>0</u> (A) Total Number of Dominant Species Across All Strata: <u>1</u> (B) Percent of Dominant Species That Are OBL, FACW, or FAC: <u>0.0%</u> (A/B)																												
1.	Species Name	% Cover	Dominant	Ind. Status																													
2.	--	--	--	--																													
3.	--	--	--	--																													
4.	--	--	--	--																													
5.	--	--	--	--																													
6.	--	--	--	--																													
7.	--	--	--	--																													
8.	--	--	--	--																													
9.	--	--	--	--																													
Total Cover =		0																															
Sapling/Shrub Stratum (Plot size: 15 ft radius)					Prevalence Index Worksheet Total % Cover of: <table style="margin-left: 20px; border-collapse: collapse;"> <tr> <td>OBL spp.</td><td><u>0</u></td><td>x 1 =</td><td><u>0</u></td> </tr> <tr> <td>FACW spp.</td><td><u>0</u></td><td>x 2 =</td><td><u>0</u></td> </tr> <tr> <td>FAC spp.</td><td><u>0</u></td><td>x 3 =</td><td><u>0</u></td> </tr> <tr> <td>FACU spp.</td><td><u>0</u></td><td>x 4 =</td><td><u>0</u></td> </tr> <tr> <td>UPL spp.</td><td><u>20</u></td><td>x 5 =</td><td><u>100</u></td> </tr> <tr> <td colspan="2" style="text-align: right;">Total</td> <td><u>20</u> (A)</td> <td><u>100</u> (B)</td> </tr> <tr> <td colspan="4" style="text-align: right;">Prevalence Index = B/A = <u>5.000</u></td> </tr> </table>	OBL spp.	<u>0</u>	x 1 =	<u>0</u>	FACW spp.	<u>0</u>	x 2 =	<u>0</u>	FAC spp.	<u>0</u>	x 3 =	<u>0</u>	FACU spp.	<u>0</u>	x 4 =	<u>0</u>	UPL spp.	<u>20</u>	x 5 =	<u>100</u>	Total		<u>20</u> (A)	<u>100</u> (B)	Prevalence Index = B/A = <u>5.000</u>			
OBL spp.	<u>0</u>	x 1 =	<u>0</u>																														
FACW spp.	<u>0</u>	x 2 =	<u>0</u>																														
FAC spp.	<u>0</u>	x 3 =	<u>0</u>																														
FACU spp.	<u>0</u>	x 4 =	<u>0</u>																														
UPL spp.	<u>20</u>	x 5 =	<u>100</u>																														
Total		<u>20</u> (A)	<u>100</u> (B)																														
Prevalence Index = B/A = <u>5.000</u>																																	
1.	--	--	--	--																													
2.	--	--	--	--																													
3.	--	--	--	--																													
4.	--	--	--	--																													
5.	--	--	--	--																													
6.	--	--	--	--																													
7.	--	--	--	--																													
8.	--	--	--	--																													
9.	--	--	--	--																													
10.	--	--	--	--																													
Total Cover =		0																															
Herb Stratum (Plot size: 5 ft radius)					Hydrophytic Vegetation Indicators: <input type="checkbox"/> Yes <input checked="" type="checkbox"/> No Rapid Test for Hydrophytic Vegetation <input type="checkbox"/> Yes <input checked="" type="checkbox"/> No Dominance Test is > 50% <input type="checkbox"/> Yes <input checked="" type="checkbox"/> No Prevalence Index is ≤ 3.0 * <input type="checkbox"/> Yes <input type="checkbox"/> No Morphological Adaptations (Explain) * <input type="checkbox"/> Yes <input type="checkbox"/> No Problem Hydrophytic Vegetation (Explain) * * Indicators of hydric soil and wetland hydrology must be present, unless disturbed or problematic.																												
1.	<i>TRITICUM spp.</i>	20	Y	UPL																													
2.	--	--	--	--																													
3.	--	--	--	--																													
4.	--	--	--	--																													
5.	--	--	--	--																													
6.	--	--	--	--																													
7.	--	--	--	--																													
8.	--	--	--	--																													
9.	--	--	--	--																													
10.	--	--	--	--																													
11.	--	--	--	--																													
12.	--	--	--	--																													
13.	--	--	--	--																													
14.	--	--	--	--																													
15.	--	--	--	--																													
Total Cover =		20																															
Woody Vine Stratum (Plot size: 30 ft radius)					Definitions of Vegetation Strata: <p style="margin-left: 40px;">Tree - Woody plants 3 in. (7.6cm) or more in diameter at breast height (DBH), regardless of height.</p> <p style="margin-left: 40px;">Sapling/Shrub - Woody plants less than 3 in. DBH and greater than 3.28 ft. tall.</p> <p style="margin-left: 40px;">Herb - All herbaceous (non-woody) plants, regardless of size, and woody plants less than 3.28 ft. tall.</p> <p style="margin-left: 40px;">Woody Vines - All woody vines greater than 3.28 ft. in height.</p>																												
1.	--	--	--	--																													
2.	--	--	--	--																													
3.	--	--	--	--																													
4.	--	--	--	--																													
5.	--	--	--	--																													
Total Cover =		0																															
Remarks: Agricultural wheat commodity successfully harvested.																																	

Additional Remarks:
Sample point located in the area of a wet signature identified from FSA slides. The sample point is in a successfully cropped field, lacking hydrophytic, hydrologic, and hydric soil indicators. The sample point is not a wetland feature.

Project/Site: Harmony Solar Array		Stantec Project #: 193704812	Date: 10/20/16
Applicant: Harmony Solar ND LLC			County: Cass
Investigator #1: Joseph Sander		Investigator #2:	State: North Dakota
Soil Unit: I371A Bearden-Kindred silty clay loams	NWI Classification: None	Wetland ID: N/A	Sample Point: U6
Landform: Swailes, Flats	Local Relief: None	Community ID: Agricultural commodity	Section: 16
Slope (%): 0-2	Latitude: --	Longitude: --	Datum: NAD 83
Are climatic/hydrologic conditions on the site typical for this time of year? (If no, explain in remarks) <input checked="" type="checkbox"/> Yes <input type="checkbox"/> No			Township: 140N
Are Vegetation <input checked="" type="checkbox"/> , Soil <input checked="" type="checkbox"/> , or Hydrology <input checked="" type="checkbox"/> significantly disturbed?		Are normal circumstances present? <input type="checkbox"/> Yes <input checked="" type="checkbox"/> No	
Are Vegetation <input type="checkbox"/> , Soil <input type="checkbox"/> , or Hydrology <input type="checkbox"/> naturally problematic?		<input type="checkbox"/> Yes <input checked="" type="checkbox"/> No	
Remarks: Sample point is located in a successfully cropped area of an agricultural field subjected to frequent tilling.		Range: \$1W Dir: --	

SUMMARY OF FINDINGS

Hydrophytic Vegetation Present? <input type="checkbox"/> Yes <input checked="" type="checkbox"/> No	Hydric Soils Present? <input type="checkbox"/> Yes <input checked="" type="checkbox"/> No
Wetland Hydrology Present? <input type="checkbox"/> Yes <input checked="" type="checkbox"/> No	Is This Sampling Point Within A Wetland? <input checked="" type="checkbox"/> Yes <input type="checkbox"/> No

Remarks: **Sample point is located in a successfully cropped area of an agricultural field subjected to frequent tilling.**

HYDROLOGY

Wetland Hydrology Indicators (Check here if indicators are not present):

<p><u>Primary:</u></p> <ul style="list-style-type: none"> <input type="checkbox"/> A1 - Surface Water <input type="checkbox"/> A2 - High Water Table <input type="checkbox"/> A3 - Saturation <input type="checkbox"/> B1 - Water Marks <input type="checkbox"/> B2 - Sediment Deposits <input type="checkbox"/> B3 - Drift Deposits <input type="checkbox"/> B4 - Algal Mat or Crust <input type="checkbox"/> B5 - Iron Deposits <input type="checkbox"/> B7 - Inundation Visible on Aerial Imagery <input type="checkbox"/> B9 - Water Stained Leaves 	<ul style="list-style-type: none"> <input type="checkbox"/> B11 - Salt Crust <input type="checkbox"/> B13 - Aquatic Invertebrates <input type="checkbox"/> C1 - Hydrogen Sulfide Odor <input type="checkbox"/> C2 - Dry-Season Water Table <input type="checkbox"/> C3 - Oxidized Rhizospheres on Living Roots (where not tilled) <input type="checkbox"/> C4 - Presence of Reduced Iron <input type="checkbox"/> C7 - Thin Muck Surface <input type="checkbox"/> Other (Explain in Remarks) 	<p><u>Secondary:</u></p> <ul style="list-style-type: none"> <input type="checkbox"/> B6 - Surface Soil Cracks <input type="checkbox"/> B8 - Sparsely Vegetated Concave Surface <input type="checkbox"/> B10 - Drainage Patterns <input type="checkbox"/> C3 - Oxidized Rhizospheres on Living Roots (where tilled) <input type="checkbox"/> C8 - Crayfish Burrows <input type="checkbox"/> C9 - Saturation Visible on Aerial Imagery <input type="checkbox"/> D2 - Geomorphic Position <input type="checkbox"/> D5 - FAC-Neutral Test <input type="checkbox"/> D7 - Frost-Heave Hummocks (LRR F)
---	--	---

Field Observations:

Surface Water Present? <input type="checkbox"/> Yes <input checked="" type="checkbox"/> No	Depth: 0 (in.)	Wetland Hydrology Present? <input type="checkbox"/> Yes <input checked="" type="checkbox"/> No
Water Table Present? <input type="checkbox"/> Yes <input checked="" type="checkbox"/> No	Depth: >24 (in.)	
Saturation Present? <input type="checkbox"/> Yes <input checked="" type="checkbox"/> No	Depth: >24 (in.)	

Describe Recorded Data (stream gauge, monitoring well, aerial photos, previous inspections), if available: **N/A**

Remarks: **Sample point is located in a flat area without discernable slope differentiation from topographical surroundings.**

SOILS

Map Unit Name: **I371A Bearden-Kindred silty clay loams** Series Drainage Class: **Somewhat poorly drained**

Taxonomy (Subgroup):

Profile Description (Describe to the depth needed to document the indicator or confirm the absence of indicators.) (Type: C=Concentration, D=Depletion, RM=Reduced Matrix, CS=Covered/Coated Sand Grains, Location: PL=Pore Lining, M=Matrix)

Top Depth	Bottom Depth	Horizon	Matrix			Redox Features				Texture (e.g. clay, sand, loam)	
			Color (Moist)	%		Color (Moist)	%	Type	Location		
0	8	Ap	10YR	2/1	100	--	None	--	--	--	silty clay loam
8	20	A	10YR	2/1	100	--	None	--	--	--	silty clay loam
20	24	B	10YR	4/2	100	--	None	--	--	--	silty clay loam
--	--	--	--	--	--	--	--	--	--	--	--
--	--	--	--	--	--	--	--	--	--	--	--
--	--	--	--	--	--	--	--	--	--	--	--
--	--	--	--	--	--	--	--	--	--	--	--

NRCS Hydric Soil Field Indicators (check here if indicators are not present):

<ul style="list-style-type: none"> <input type="checkbox"/> A1 - Histosol <input type="checkbox"/> A2 - Histic Epipedon <input type="checkbox"/> A3 - Black Histic <input type="checkbox"/> A4 - Hydrogen Sulfide <input type="checkbox"/> A5 - Stratified Layers (LRR F) <input type="checkbox"/> A9 - 1 cm Muck (LRR F, G, H) <input type="checkbox"/> A11 - Depleted Below Dark Surface <input type="checkbox"/> A12 - Thick Dark Surface <input type="checkbox"/> S1 - Sandy Muck Mineral <input type="checkbox"/> S2 - 2.5 cm Mucky Peat or Peat (LRR G, H) 	<ul style="list-style-type: none"> <input type="checkbox"/> S3 - 5cm Mucky Peat or Peat (LRR F) <input type="checkbox"/> S4 - Sandy Gleyed Matrix <input type="checkbox"/> S5 - Sandy Redox <input type="checkbox"/> S6 - Stripped Matrix <input type="checkbox"/> F1 - Loamy Mucky Mineral <input type="checkbox"/> F2 Loamy Gleyed Matrix <input type="checkbox"/> F3 - Depleted Matrix <input type="checkbox"/> F6 - Redox Dark Surface <input type="checkbox"/> F7 - Depleted Dark Surface <input type="checkbox"/> F8 - Redox Depressions 	<ul style="list-style-type: none"> <input type="checkbox"/> F16 - High Plains Depressions (MLRA 72, 73 of LRR H) <input type="checkbox"/> A9 - 1cm Muck (LRR I, J) <input type="checkbox"/> A16 - Coast Prairie Redox (LRR F, G, H) <input type="checkbox"/> S7 - Dark Surface (LRR G) <input type="checkbox"/> F16 - High Plains Depressions (LRR H outside MLRA 72, 73) <input type="checkbox"/> F18 - Reduced Vertic <input type="checkbox"/> TF2 - Red Parent Material <input type="checkbox"/> TF12 - Very Shallow Dark Surface <input type="checkbox"/> Other (Explain in Remarks)
--	--	---

¹ Indicators of hydrophytic vegetation and wetland hydrology must be present, unless disturbed or problematic.

Restrictive Layer (If Observed) Type: N/A	Depth: N/A	Hydric Soil Present? <input type="checkbox"/> Yes <input checked="" type="checkbox"/> No
--	-------------------	---

Remarks: **The only applicable hydric soil indicator beyond 12" is "Thick Dark Surface (A12)," for which this sample point does not meet the requirements.**

Project/Site: **Harmony Solar Array** Wetland ID: **N/A** Sample Point **U6**
VEGETATION (Species identified in all uppercase are non-native species.)

Tree Stratum (Plot size: 30 ft radius)					Dominance Test Worksheet Number of Dominant Species that are OBL, FACW, or FAC: <u>0</u> (A) Total Number of Dominant Species Across All Strata: <u>1</u> (B) Percent of Dominant Species That Are OBL, FACW, or FAC: <u>0.0%</u> (A/B)																												
1.	Species Name	% Cover	Dominant	Ind. Status																													
2.	--	--	--	--																													
3.	--	--	--	--																													
4.	--	--	--	--																													
5.	--	--	--	--																													
6.	--	--	--	--																													
7.	--	--	--	--																													
8.	--	--	--	--																													
9.	--	--	--	--																													
Total Cover =		0																															
Sapling/Shrub Stratum (Plot size: 15 ft radius)					Prevalence Index Worksheet Total % Cover of: <table style="margin-left: 20px; border-collapse: collapse;"> <tr> <td>OBL spp.</td><td><u>0</u></td><td>x 1 =</td><td><u>0</u></td> </tr> <tr> <td>FACW spp.</td><td><u>0</u></td><td>x 2 =</td><td><u>0</u></td> </tr> <tr> <td>FAC spp.</td><td><u>0</u></td><td>x 3 =</td><td><u>0</u></td> </tr> <tr> <td>FACU spp.</td><td><u>0</u></td><td>x 4 =</td><td><u>0</u></td> </tr> <tr> <td>UPL spp.</td><td><u>20</u></td><td>x 5 =</td><td><u>100</u></td> </tr> <tr> <td colspan="2" style="text-align: right;">Total</td> <td><u>20</u> (A)</td> <td><u>100</u> (B)</td> </tr> <tr> <td colspan="2" style="text-align: right;">Prevalence Index = B/A =</td> <td colspan="2"><u>5.000</u></td> </tr> </table>	OBL spp.	<u>0</u>	x 1 =	<u>0</u>	FACW spp.	<u>0</u>	x 2 =	<u>0</u>	FAC spp.	<u>0</u>	x 3 =	<u>0</u>	FACU spp.	<u>0</u>	x 4 =	<u>0</u>	UPL spp.	<u>20</u>	x 5 =	<u>100</u>	Total		<u>20</u> (A)	<u>100</u> (B)	Prevalence Index = B/A =		<u>5.000</u>	
OBL spp.	<u>0</u>	x 1 =	<u>0</u>																														
FACW spp.	<u>0</u>	x 2 =	<u>0</u>																														
FAC spp.	<u>0</u>	x 3 =	<u>0</u>																														
FACU spp.	<u>0</u>	x 4 =	<u>0</u>																														
UPL spp.	<u>20</u>	x 5 =	<u>100</u>																														
Total		<u>20</u> (A)	<u>100</u> (B)																														
Prevalence Index = B/A =		<u>5.000</u>																															
1.	--	--	--	--																													
2.	--	--	--	--																													
3.	--	--	--	--																													
4.	--	--	--	--																													
5.	--	--	--	--																													
6.	--	--	--	--																													
7.	--	--	--	--																													
8.	--	--	--	--																													
9.	--	--	--	--																													
10.	--	--	--	--																													
Total Cover =		0																															
Herb Stratum (Plot size: 5 ft radius)					Hydrophytic Vegetation Indicators: <input type="checkbox"/> Yes <input checked="" type="checkbox"/> No Rapid Test for Hydrophytic Vegetation <input type="checkbox"/> Yes <input checked="" type="checkbox"/> No Dominance Test is > 50% <input type="checkbox"/> Yes <input checked="" type="checkbox"/> No Prevalence Index is ≤ 3.0 * <input type="checkbox"/> Yes <input type="checkbox"/> No Morphological Adaptations (Explain) * <input type="checkbox"/> Yes <input type="checkbox"/> No Problem Hydrophytic Vegetation (Explain) * * Indicators of hydric soil and wetland hydrology must be present, unless disturbed or problematic.																												
1.	<i>TRITICUM spp.</i>	20	Y	UPL																													
2.	--	--	--	--																													
3.	--	--	--	--																													
4.	--	--	--	--																													
5.	--	--	--	--																													
6.	--	--	--	--																													
7.	--	--	--	--																													
8.	--	--	--	--																													
9.	--	--	--	--																													
10.	--	--	--	--																													
11.	--	--	--	--																													
12.	--	--	--	--																													
13.	--	--	--	--																													
14.	--	--	--	--																													
15.	--	--	--	--																													
Total Cover =		20																															
Woody Vine Stratum (Plot size: 30 ft radius)					Definitions of Vegetation Strata: <p style="margin-left: 40px;">Tree - Woody plants 3 in. (7.6cm) or more in diameter at breast height (DBH), regardless of height.</p> <p style="margin-left: 40px;">Sapling/Shrub - Woody plants less than 3 in. DBH and greater than 3.28 ft. tall.</p> <p style="margin-left: 40px;">Herb - All herbaceous (non-woody) plants, regardless of size, and woody plants less than 3.28 ft. tall.</p> <p style="margin-left: 40px;">Woody Vines - All woody vines greater than 3.28 ft. in height.</p>																												
1.	--	--	--	--																													
2.	--	--	--	--																													
3.	--	--	--	--																													
4.	--	--	--	--																													
5.	--	--	--	--																													
Total Cover =		0																															
Remarks: Agricultural wheat commodity successfully harvested.																																	

Additional Remarks:
Sample point located in the area of a wet signature identified from FSA slides. The sample point is in a successfully cropped field, lacking hydrophytic, hydrologic, and hydric soil indicators. The sample point is not a wetland feature.

Project/Site: Harmony Solar Array		Stantec Project #: 193704812		Date: 10/20/16
Applicant: Harmony Solar ND LLC		Investigator #1: Joseph Sander		County: Cass
Soil Unit: I371A Bearden-Kindred silty clay loams		Investigator #2:		State: North Dakota
Landform: Swailes, Flats		Local Relief: None		Wetland ID: N/A
Slope (%): 0-2		Latitude: --		Sample Point: U7
		Longitude: --		Community ID: Agricultural commodity
		Datum: NAD 83		Section: 16
Are climatic/hydrologic conditions on the site typical for this time of year? <input checked="" type="checkbox"/> Yes <input type="checkbox"/> No		Are normal circumstances present? <input type="checkbox"/> Yes <input checked="" type="checkbox"/> No		Township: 140N
Are Vegetation <input checked="" type="checkbox"/> , Soil <input checked="" type="checkbox"/> , or Hydrology <input checked="" type="checkbox"/> significantly disturbed?				Range: \$1W Dir: --
Are Vegetation <input type="checkbox"/> , Soil <input type="checkbox"/> , or Hydrology <input type="checkbox"/> naturally problematic?				

SUMMARY OF FINDINGS

Hydrophytic Vegetation Present? <input type="checkbox"/> Yes <input checked="" type="checkbox"/> No	Hydric Soils Present? <input type="checkbox"/> Yes <input checked="" type="checkbox"/> No
Wetland Hydrology Present? <input type="checkbox"/> Yes <input checked="" type="checkbox"/> No	Is This Sampling Point Within A Wetland? <input checked="" type="checkbox"/> Yes <input type="checkbox"/> No

Remarks: **Sample point is located in a successfully cropped area of an agricultural field subjected to frequent tilling.**

HYDROLOGY

Wetland Hydrology Indicators (Check here if indicators are not present):

<p><u>Primary:</u></p> <ul style="list-style-type: none"> <input type="checkbox"/> A1 - Surface Water <input type="checkbox"/> A2 - High Water Table <input type="checkbox"/> A3 - Saturation <input type="checkbox"/> B1 - Water Marks <input type="checkbox"/> B2 - Sediment Deposits <input type="checkbox"/> B3 - Drift Deposits <input type="checkbox"/> B4 - Algal Mat or Crust <input type="checkbox"/> B5 - Iron Deposits <input type="checkbox"/> B7 - Inundation Visible on Aerial Imagery <input type="checkbox"/> B9 - Water Stained Leaves 	<ul style="list-style-type: none"> <input type="checkbox"/> B11 - Salt Crust <input type="checkbox"/> B13 - Aquatic Invertebrates <input type="checkbox"/> C1 - Hydrogen Sulfide Odor <input type="checkbox"/> C2 - Dry-Season Water Table <input type="checkbox"/> C3 - Oxidized Rhizospheres on Living Roots (where not tilled) <input type="checkbox"/> C4 - Presence of Reduced Iron <input type="checkbox"/> C7 - Thin Muck Surface <input type="checkbox"/> Other (Explain in Remarks) 	<p><u>Secondary:</u></p> <ul style="list-style-type: none"> <input type="checkbox"/> B6 - Surface Soil Cracks <input type="checkbox"/> B8 - Sparsely Vegetated Concave Surface <input type="checkbox"/> B10 - Drainage Patterns <input type="checkbox"/> C3 - Oxidized Rhizospheres on Living Roots (where tilled) <input type="checkbox"/> C8 - Crayfish Burrows <input type="checkbox"/> C9 - Saturation Visible on Aerial Imagery <input type="checkbox"/> D2 - Geomorphic Position <input type="checkbox"/> D5 - FAC-Neutral Test <input type="checkbox"/> D7 - Frost-Heave Hummocks (LRR F)
---	--	---

Field Observations:

Surface Water Present? <input type="checkbox"/> Yes <input checked="" type="checkbox"/> No	Depth: 0 (in.)	Wetland Hydrology Present? <input type="checkbox"/> Yes <input checked="" type="checkbox"/> No
Water Table Present? <input type="checkbox"/> Yes <input checked="" type="checkbox"/> No	Depth: >24 (in.)	
Saturation Present? <input type="checkbox"/> Yes <input checked="" type="checkbox"/> No	Depth: >24 (in.)	

Describe Recorded Data (stream gauge, monitoring well, aerial photos, previous inspections), if available: **N/A**

Remarks: **Sample point is located in a flat area without discernable slope differentiation from topographical surroundings.**

SOILS

Map Unit Name: **I371A Bearden-Kindred silty clay loams** Series Drainage Class: **Somewhat poorly drained**

Taxonomy (Subgroup):

Profile Description (Describe to the depth needed to document the indicator or confirm the absence of indicators.) (Type: C=Concentration, D=Depletion, RM=Reduced Matrix, CS=Covered/Coated Sand Grains, Location: PL=Pore Lining, M=Matrix)

Top Depth	Bottom Depth	Horizon	Matrix			Redox Features				Texture (e.g. clay, sand, loam)	
			Color (Moist)	%		Color (Moist)	%	Type	Location		
0	8	Ap	10YR	2/1	100	--	None	--	--	--	silty clay loam
8	20	A	10YR	2/1	100	--	None	--	--	--	silty clay loam
20	24	B	10YR	4/2	100	--	None	--	--	--	silty clay loam
--	--	--	--	--	--	--	--	--	--	--	--
--	--	--	--	--	--	--	--	--	--	--	--
--	--	--	--	--	--	--	--	--	--	--	--
--	--	--	--	--	--	--	--	--	--	--	--

NRCS Hydric Soil Field Indicators (check here if indicators are not present):

<ul style="list-style-type: none"> <input type="checkbox"/> A1 - Histosol <input type="checkbox"/> A2 - Histic Epipedon <input type="checkbox"/> A3 - Black Histic <input type="checkbox"/> A4 - Hydrogen Sulfide <input type="checkbox"/> A5 - Stratified Layers (LRR F) <input type="checkbox"/> A9 - 1 cm Muck (LRR F, G, H) <input type="checkbox"/> A11 - Depleted Below Dark Surface <input type="checkbox"/> A12 - Thick Dark Surface <input type="checkbox"/> S1 - Sandy Muck Mineral <input type="checkbox"/> S2 - 2.5 cm Mucky Peat or Peat (LRR G, H) 	<ul style="list-style-type: none"> <input type="checkbox"/> S3 - 5cm Mucky Peat or Peat (LRR F) <input type="checkbox"/> S4 - Sandy Gleyed Matrix <input type="checkbox"/> S5 - Sandy Redox <input type="checkbox"/> S6 - Stripped Matrix <input type="checkbox"/> F1 - Loamy Mucky Mineral <input type="checkbox"/> F2 Loamy Gleyed Matrix <input type="checkbox"/> F3 - Depleted Matrix <input type="checkbox"/> F6 - Redox Dark Surface <input type="checkbox"/> F7 - Depleted Dark Surface <input type="checkbox"/> F8 - Redox Depressions 	<ul style="list-style-type: none"> <input type="checkbox"/> F16 - High Plains Depressions (MLRA 72, 73 of LRR H) <input type="checkbox"/> A9 - 1cm Muck (LRR I, J) <input type="checkbox"/> A16 - Coast Prairie Redox (LRR F, G, H) <input type="checkbox"/> S7 - Dark Surface (LRR G) <input type="checkbox"/> F16 - High Plains Depressions (LRR H outside MLRA 72, 73) <input type="checkbox"/> F18 - Reduced Vertic <input type="checkbox"/> TF2 - Red Parent Material <input type="checkbox"/> TF12 - Very Shallow Dark Surface <input type="checkbox"/> Other (Explain in Remarks)
--	--	---

¹ Indicators of hydrophytic vegetation and wetland hydrology must be present, unless disturbed or problematic.

Restrictive Layer (If Observed) Type: N/A	Depth: N/A	Hydric Soil Present? <input type="checkbox"/> Yes <input checked="" type="checkbox"/> No
--	-------------------	---

Remarks: **The only applicable hydric soil indicator beyond 12" is "Thick Dark Surface (A12)," for which this sample point does not meet the requirements.**

Project/Site: **Harmony Solar Array** Wetland ID: **N/A** Sample Point **U7**
VEGETATION (Species identified in all uppercase are non-native species.)

Tree Stratum (Plot size: 30 ft radius)				
	Species Name	% Cover	Dominant	Ind. Status
1.	--	--	--	--
2.	--	--	--	--
3.	--	--	--	--
4.	--	--	--	--
5.	--	--	--	--
6.	--	--	--	--
7.	--	--	--	--
8.	--	--	--	--
9.	--	--	--	--
10.	--	--	--	--
Total Cover =		0		

Dominance Test Worksheet	
Number of Dominant Species that are OBL, FACW, or FAC:	<u>0</u> (A)
Total Number of Dominant Species Across All Strata:	<u>1</u> (B)
Percent of Dominant Species That Are OBL, FACW, or FAC:	<u>0.0%</u> (A/B)

Sapling/Shrub Stratum (Plot size: 15 ft radius)				
	Species Name	% Cover	Dominant	Ind. Status
1.	--	--	--	--
2.	--	--	--	--
3.	--	--	--	--
4.	--	--	--	--
5.	--	--	--	--
6.	--	--	--	--
7.	--	--	--	--
8.	--	--	--	--
9.	--	--	--	--
10.	--	--	--	--
Total Cover =		0		

Prevalence Index Worksheet	
Total % Cover of:	Multiply by:
OBL spp. <u>0</u>	x 1 = <u>0</u>
FACW spp. <u>0</u>	x 2 = <u>0</u>
FAC spp. <u>0</u>	x 3 = <u>0</u>
FACU spp. <u>0</u>	x 4 = <u>0</u>
UPL spp. <u>20</u>	x 5 = <u>100</u>
Total <u>20</u> (A)	<u>100</u> (B)
Prevalence Index = B/A = <u>5.000</u>	

Herb Stratum (Plot size: 5 ft radius)				
	Species Name	% Cover	Dominant	Ind. Status
1.	<i>TRITICUM spp.</i>	20	Y	UPL
2.	--	--	--	--
3.	--	--	--	--
4.	--	--	--	--
5.	--	--	--	--
6.	--	--	--	--
7.	--	--	--	--
8.	--	--	--	--
9.	--	--	--	--
10.	--	--	--	--
11.	--	--	--	--
12.	--	--	--	--
13.	--	--	--	--
14.	--	--	--	--
15.	--	--	--	--
Total Cover =		20		

Hydrophytic Vegetation Indicators:		
<input type="checkbox"/> Yes	<input checked="" type="checkbox"/> No	Rapid Test for Hydrophytic Vegetation
<input type="checkbox"/> Yes	<input checked="" type="checkbox"/> No	Dominance Test is > 50%
<input type="checkbox"/> Yes	<input checked="" type="checkbox"/> No	Prevalence Index is ≤ 3.0 *
<input type="checkbox"/> Yes	<input type="checkbox"/> No	Morphological Adaptations (Explain) *
<input type="checkbox"/> Yes	<input type="checkbox"/> No	Problem Hydrophytic Vegetation (Explain) *

* Indicators of hydric soil and wetland hydrology must be present, unless disturbed or problematic.

Woody Vine Stratum (Plot size: 30 ft radius)				
	Species Name	% Cover	Dominant	Ind. Status
1.	--	--	--	--
2.	--	--	--	--
3.	--	--	--	--
4.	--	--	--	--
5.	--	--	--	--
Total Cover =		0		

Definitions of Vegetation Strata:	
Tree	Woody plants 3 in. (7.6cm) or more in diameter at breast height (DBH), regardless of height.
Sapling/Shrub	Woody plants less than 3 in. DBH and greater than 3.28 ft. tall.
Herb	All herbaceous (non-woody) plants, regardless of size, and woody plants less than 3.28 ft. tall.
Woody Vines	All woody vines greater than 3.28 ft. in height.

 Remarks: **Agricultural wheat commodity successfully harvested.**

Hydrophytic Vegetation Present	<input type="checkbox"/> Yes	<input checked="" type="checkbox"/> No
---------------------------------------	------------------------------	--

Additional Remarks:

Sample point located in the area of a wet signature identified from FSA slides. The sample point is in a successfully cropped field, lacking hydrophytic, hydrologic, and hydric soil indicators. The sample point is not a wetland feature.

Project/Site: Harmony Solar Array		Stantec Project #: 193704812	Date: 10/20/16
Applicant: Harmony Solar ND LLC			County: Cass
Investigator #1: Joseph Sander		Investigator #2:	State: North Dakota
Soil Unit: I235A Fargo silty clay, depressional	NWI Classification: None		Wetland ID: N/A
Landform: Depression	Local Relief: None		Sample Point: U8
Slope (%): 0-1	Latitude: --	Longitude: --	Datum: NAD 83
Are climatic/hydrologic conditions on the site typical for this time of year? (If no, explain in remarks) <input checked="" type="checkbox"/> Yes <input type="checkbox"/> No			Community ID: Agricultural commodity
Are Vegetation <input checked="" type="checkbox"/> , Soil <input checked="" type="checkbox"/> , or Hydrology <input checked="" type="checkbox"/> significantly disturbed?		Are normal circumstances present? <input type="checkbox"/> Yes <input checked="" type="checkbox"/> No	
Are Vegetation <input type="checkbox"/> , Soil <input type="checkbox"/> , or Hydrology <input type="checkbox"/> naturally problematic? <input type="checkbox"/> Yes <input checked="" type="checkbox"/> No		Township: 140N	
		Range: \$1W Dir: --	

SUMMARY OF FINDINGS

Hydrophytic Vegetation Present? <input type="checkbox"/> Yes <input checked="" type="checkbox"/> No	Hydric Soils Present? <input type="checkbox"/> Yes <input checked="" type="checkbox"/> No
Wetland Hydrology Present? <input type="checkbox"/> Yes <input checked="" type="checkbox"/> No	Is This Sampling Point Within A Wetland? <input checked="" type="checkbox"/> Yes <input type="checkbox"/> No

Remarks: **Sample point is located in a successfully cropped area of an agricultural field subjected to frequent tilling.**

HYDROLOGY

Wetland Hydrology Indicators (Check here if indicators are not present):

<p><u>Primary:</u></p> <ul style="list-style-type: none"> <input type="checkbox"/> A1 - Surface Water <input type="checkbox"/> A2 - High Water Table <input type="checkbox"/> A3 - Saturation <input type="checkbox"/> B1 - Water Marks <input type="checkbox"/> B2 - Sediment Deposits <input type="checkbox"/> B3 - Drift Deposits <input type="checkbox"/> B4 - Algal Mat or Crust <input type="checkbox"/> B5 - Iron Deposits <input type="checkbox"/> B7 - Inundation Visible on Aerial Imagery <input type="checkbox"/> B9 - Water Stained Leaves 	<ul style="list-style-type: none"> <input type="checkbox"/> B11 - Salt Crust <input type="checkbox"/> B13 - Aquatic Invertebrates <input type="checkbox"/> C1 - Hydrogen Sulfide Odor <input type="checkbox"/> C2 - Dry-Season Water Table <input type="checkbox"/> C3 - Oxidized Rhizospheres on Living Roots (where not tilled) <input type="checkbox"/> C4 - Presence of Reduced Iron <input type="checkbox"/> C7 - Thin Muck Surface <input type="checkbox"/> Other (Explain in Remarks) 	<p><u>Secondary:</u></p> <ul style="list-style-type: none"> <input type="checkbox"/> B6 - Surface Soil Cracks <input type="checkbox"/> B8 - Sparsely Vegetated Concave Surface <input type="checkbox"/> B10 - Drainage Patterns <input type="checkbox"/> C3 - Oxidized Rhizospheres on Living Roots (where tilled) <input type="checkbox"/> C8 - Crayfish Burrows <input type="checkbox"/> C9 - Saturation Visible on Aerial Imagery <input type="checkbox"/> D2 - Geomorphic Position <input type="checkbox"/> D5 - FAC-Neutral Test <input type="checkbox"/> D7 - Frost-Heave Hummocks (LRR F)
---	--	---

Field Observations:

Surface Water Present? <input type="checkbox"/> Yes <input checked="" type="checkbox"/> No	Depth: 0 (in.)	Wetland Hydrology Present? <input type="checkbox"/> Yes <input checked="" type="checkbox"/> No
Water Table Present? <input type="checkbox"/> Yes <input checked="" type="checkbox"/> No	Depth: >24 (in.)	
Saturation Present? <input type="checkbox"/> Yes <input checked="" type="checkbox"/> No	Depth: >24 (in.)	

Describe Recorded Data (stream gauge, monitoring well, aerial photos, previous inspections), if available: **N/A**

Remarks: **Sample point is located in a flat area without discernable slope differentiation from topographical surroundings.**

SOILS

Map Unit Name: **I235A Fargo silty clay, depressional** Series Drainage Class: **Poorly drained**

Taxonomy (Subgroup):

Profile Description (Describe to the depth needed to document the indicator or confirm the absence of indicators.) (Type: C=Concentration, D=Depletion, RM=Reduced Matrix, CS=Covered/Coated Sand Grains, Location: PL=Pore Lining, M=Matrix)

Top Depth	Bottom Depth	Horizon	Matrix			Redox Features				Texture (e.g. clay, sand, loam)	
			Color (Moist)	%		Color (Moist)	%	Type	Location		
0	8	Ap	10YR	2/1	100	--	None	--	--	--	silty clay
8	20	A	10YR	2/1	100	--	None	--	--	--	silty clay
20	24	B	10YR	4/2	100	--	None	--	--	--	silty clay
--	--	--	--	--	--	--	--	--	--	--	--
--	--	--	--	--	--	--	--	--	--	--	--
--	--	--	--	--	--	--	--	--	--	--	--
--	--	--	--	--	--	--	--	--	--	--	--

NRCS Hydric Soil Field Indicators (check here if indicators are not present):

<ul style="list-style-type: none"> <input type="checkbox"/> A1 - Histosol <input type="checkbox"/> A2 - Histic Epipedon <input type="checkbox"/> A3 - Black Histic <input type="checkbox"/> A4 - Hydrogen Sulfide <input type="checkbox"/> A5 - Stratified Layers (LRR F) <input type="checkbox"/> A9 - 1 cm Muck (LRR F, G, H) <input type="checkbox"/> A11 - Depleted Below Dark Surface <input type="checkbox"/> A12 - Thick Dark Surface <input type="checkbox"/> S1 - Sandy Muck Mineral <input type="checkbox"/> S2 - 2.5 cm Mucky Peat or Peat (LRR G, H) 	<ul style="list-style-type: none"> <input type="checkbox"/> S3 - 5cm Mucky Peat or Peat (LRR F) <input type="checkbox"/> S4 - Sandy Gleyed Matrix <input type="checkbox"/> S5 - Sandy Redox <input type="checkbox"/> S6 - Stripped Matrix <input type="checkbox"/> F1 - Loamy Mucky Mineral <input type="checkbox"/> F2 Loamy Gleyed Matrix <input type="checkbox"/> F3 - Depleted Matrix <input type="checkbox"/> F6 - Redox Dark Surface <input type="checkbox"/> F7 - Depleted Dark Surface <input type="checkbox"/> F8 - Redox Depressions 	<ul style="list-style-type: none"> <input type="checkbox"/> F16 - High Plains Depressions (MLRA 72, 73 of LRR H) <input type="checkbox"/> A9 - 1cm Muck (LRR I, J) <input type="checkbox"/> A16 - Coast Prairie Redox (LRR F, G, H) <input type="checkbox"/> S7 - Dark Surface (LRR G) <input type="checkbox"/> F16 - High Plains Depressions (LRR H outside MLRA 72, 73) <input type="checkbox"/> F18 - Reduced Vertic <input type="checkbox"/> TF2 - Red Parent Material <input type="checkbox"/> TF12 - Very Shallow Dark Surface <input type="checkbox"/> Other (Explain in Remarks)
--	--	---

¹ Indicators of hydrophytic vegetation and wetland hydrology must be present, unless disturbed or problematic.

Restrictive Layer (If Observed) Type: **N/A** Depth: **N/A** **Hydric Soil Present?** Yes No

Remarks: **The only applicable hydric soil indicator beyond 12" is "Thick Dark Surface (A12)," for which this sample point does not meet the requirements.**

Project/Site: **Harmony Solar Array** Wetland ID: **N/A** Sample Point **U8**
VEGETATION (Species identified in all uppercase are non-native species.)

Tree Stratum (Plot size: 30 ft radius)				
	Species Name	% Cover	Dominant	Ind. Status
1.	--	--	--	--
2.	--	--	--	--
3.	--	--	--	--
4.	--	--	--	--
5.	--	--	--	--
6.	--	--	--	--
7.	--	--	--	--
8.	--	--	--	--
9.	--	--	--	--
10.	--	--	--	--
Total Cover =		0		

Dominance Test Worksheet	
Number of Dominant Species that are OBL, FACW, or FAC:	<u>0</u> (A)
Total Number of Dominant Species Across All Strata:	<u>1</u> (B)
Percent of Dominant Species That Are OBL, FACW, or FAC:	<u>0.0%</u> (A/B)

Sapling/Shrub Stratum (Plot size: 15 ft radius)				
	Species Name	% Cover	Dominant	Ind. Status
1.	--	--	--	--
2.	--	--	--	--
3.	--	--	--	--
4.	--	--	--	--
5.	--	--	--	--
6.	--	--	--	--
7.	--	--	--	--
8.	--	--	--	--
9.	--	--	--	--
10.	--	--	--	--
Total Cover =		0		

Prevalence Index Worksheet	
Total % Cover of:	Multiply by:
OBL spp. <u>0</u>	x 1 = <u>0</u>
FACW spp. <u>0</u>	x 2 = <u>0</u>
FAC spp. <u>0</u>	x 3 = <u>0</u>
FACU spp. <u>0</u>	x 4 = <u>0</u>
UPL spp. <u>40</u>	x 5 = <u>200</u>
Total <u>40</u> (A)	<u>200</u> (B)
Prevalence Index = B/A = <u>5.000</u>	

Herb Stratum (Plot size: 5 ft radius)				
	Species Name	% Cover	Dominant	Ind. Status
1.	<i>TRITICUM spp.</i>	40	Y	UPL
2.	--	--	--	--
3.	--	--	--	--
4.	--	--	--	--
5.	--	--	--	--
6.	--	--	--	--
7.	--	--	--	--
8.	--	--	--	--
9.	--	--	--	--
10.	--	--	--	--
11.	--	--	--	--
12.	--	--	--	--
13.	--	--	--	--
14.	--	--	--	--
15.	--	--	--	--
Total Cover =		40		

Hydrophytic Vegetation Indicators:		
<input type="checkbox"/> Yes	<input checked="" type="checkbox"/> No	Rapid Test for Hydrophytic Vegetation
<input type="checkbox"/> Yes	<input checked="" type="checkbox"/> No	Dominance Test is > 50%
<input type="checkbox"/> Yes	<input checked="" type="checkbox"/> No	Prevalence Index is ≤ 3.0 *
<input type="checkbox"/> Yes	<input type="checkbox"/> No	Morphological Adaptations (Explain) *
<input type="checkbox"/> Yes	<input type="checkbox"/> No	Problem Hydrophytic Vegetation (Explain) *

* Indicators of hydric soil and wetland hydrology must be present, unless disturbed or problematic.

Woody Vine Stratum (Plot size: 30 ft radius)				
	Species Name	% Cover	Dominant	Ind. Status
1.	--	--	--	--
2.	--	--	--	--
3.	--	--	--	--
4.	--	--	--	--
5.	--	--	--	--
Total Cover =		0		

Definitions of Vegetation Strata:	
Tree	Woody plants 3 in. (7.6cm) or more in diameter at breast height (DBH), regardless of height.
Sapling/Shrub	Woody plants less than 3 in. DBH and greater than 3.28 ft. tall.
Herb	All herbaceous (non-woody) plants, regardless of size, and woody plants less than 3.28 ft. tall.
Woody Vines	All woody vines greater than 3.28 ft. in height.

 Remarks: **Agricultural wheat commodity successfully harvested.**

Hydrophytic Vegetation Present <input type="checkbox"/> Yes <input checked="" type="checkbox"/> No

Additional Remarks:

Sample point located in the area of a wet signature identified from FSA slides. The sample point is in a successfully cropped field, lacking hydrophytic, hydrologic, and hydric soil indicators. The sample point is not a wetland feature.

Project/Site: Harmony Solar Array		Stantec Project #: 193704812	Date: 10/20/16
Applicant: Harmony Solar ND LLC			County: Cass
Investigator #1: Joseph Sander		Investigator #2:	State: North Dakota
Soil Unit: I373A Kindred-Bearden silty clay loams	NWI Classification: None	Wetland ID: N/A	Sample Point: U9
Landform: Swales, Flats	Local Relief: Concave	Community ID: Agricultural commodity	Section: 16
Slope (%): 0-2	Latitude: --	Longitude: --	Datum: NAD 83
Are climatic/hydrologic conditions on the site typical for this time of year? (If no, explain in remarks) <input checked="" type="checkbox"/> Yes <input type="checkbox"/> No		Are normal circumstances present? <input type="checkbox"/> Yes <input checked="" type="checkbox"/> No	
Are Vegetation <input checked="" type="checkbox"/> , Soil <input checked="" type="checkbox"/> , or Hydrology <input checked="" type="checkbox"/> significantly disturbed?		Are Vegetation <input type="checkbox"/> , Soil <input type="checkbox"/> , or Hydrology <input type="checkbox"/> naturally problematic? <input type="checkbox"/> Yes <input checked="" type="checkbox"/> No	
Township: 140N		Range: 51W Dir: --	

SUMMARY OF FINDINGS

Hydrophytic Vegetation Present? <input type="checkbox"/> Yes <input checked="" type="checkbox"/> No	Hydric Soils Present? <input type="checkbox"/> Yes <input checked="" type="checkbox"/> No
Wetland Hydrology Present? <input type="checkbox"/> Yes <input checked="" type="checkbox"/> No	Is This Sampling Point Within A Wetland? <input checked="" type="checkbox"/> Yes <input type="checkbox"/> No

Remarks: **Sample point is located in a successfully cropped area of an agricultural field subjected to frequent tilling.**

HYDROLOGY

Wetland Hydrology Indicators (Check here if indicators are not present):

<p><u>Primary:</u></p> <ul style="list-style-type: none"> <input type="checkbox"/> A1 - Surface Water <input type="checkbox"/> A2 - High Water Table <input type="checkbox"/> A3 - Saturation <input type="checkbox"/> B1 - Water Marks <input type="checkbox"/> B2 - Sediment Deposits <input type="checkbox"/> B3 - Drift Deposits <input type="checkbox"/> B4 - Algal Mat or Crust <input type="checkbox"/> B5 - Iron Deposits <input type="checkbox"/> B7 - Inundation Visible on Aerial Imagery <input type="checkbox"/> B9 - Water Stained Leaves 	<ul style="list-style-type: none"> <input type="checkbox"/> B11 - Salt Crust <input type="checkbox"/> B13 - Aquatic Invertebrates <input type="checkbox"/> C1 - Hydrogen Sulfide Odor <input type="checkbox"/> C2 - Dry-Season Water Table <input type="checkbox"/> C3 - Oxidized Rhizospheres on Living Roots (where not tilled) <input type="checkbox"/> C4 - Presence of Reduced Iron <input type="checkbox"/> C7 - Thin Muck Surface <input type="checkbox"/> Other (Explain in Remarks) 	<p><u>Secondary:</u></p> <ul style="list-style-type: none"> <input type="checkbox"/> B6 - Surface Soil Cracks <input type="checkbox"/> B8 - Sparsely Vegetated Concave Surface <input type="checkbox"/> B10 - Drainage Patterns <input type="checkbox"/> C3 - Oxidized Rhizospheres on Living Roots (where tilled) <input type="checkbox"/> C8 - Crayfish Burrows <input type="checkbox"/> C9 - Saturation Visible on Aerial Imagery <input checked="" type="checkbox"/> D2 - Geomorphic Position <input type="checkbox"/> D5 - FAC-Neutral Test <input type="checkbox"/> D7 - Frost-Heave Hummocks (LRR F)
---	--	--

Field Observations:

Surface Water Present? <input type="checkbox"/> Yes <input checked="" type="checkbox"/> No	Depth: 0 (in.)	Wetland Hydrology Present? <input type="checkbox"/> Yes <input checked="" type="checkbox"/> No
Water Table Present? <input type="checkbox"/> Yes <input checked="" type="checkbox"/> No	Depth: >24 (in.)	
Saturation Present? <input type="checkbox"/> Yes <input checked="" type="checkbox"/> No	Depth: >24 (in.)	

Describe Recorded Data (stream gauge, monitoring well, aerial photos, previous inspections), if available: **N/A**

Remarks: **Sample point is located in a minor swale with 1% slope differentiation from topographical surroundings.**

SOILS

Map Unit Name: **I373A Kindred-Bearden silty clay loams** Series Drainage Class: **Somewhat poorly drained**

Taxonomy (Subgroup):

Profile Description (Describe to the depth needed to document the indicator or confirm the absence of indicators.) (Type: C=Concentration, D=Depletion, RM=Reduced Matrix, CS=Covered/Coated Sand Grains, Location: PL=Pore Lining, M=Matrix)

Top Depth	Bottom Depth	Horizon	Matrix			Redox Features				Texture (e.g. clay, sand, loam)	
			Color (Moist)	%		Color (Moist)	%	Type	Location		
0	8	Ap	10YR	2/1	100	--	None	--	--	--	silty clay loam
8	24	A	10YR	2/1	100	--	None	--	--	--	silty clay loam
--	--	--	--	--	--	--	--	--	--	--	--
--	--	--	--	--	--	--	--	--	--	--	--
--	--	--	--	--	--	--	--	--	--	--	--
--	--	--	--	--	--	--	--	--	--	--	--
--	--	--	--	--	--	--	--	--	--	--	--

NRCS Hydric Soil Field Indicators (check here if indicators are not present):

<ul style="list-style-type: none"> <input type="checkbox"/> A1 - Histosol <input type="checkbox"/> A2 - Histic Epipedon <input type="checkbox"/> A3 - Black Histic <input type="checkbox"/> A4 - Hydrogen Sulfide <input type="checkbox"/> A5 - Stratified Layers (LRR F) <input type="checkbox"/> A9 - 1 cm Muck (LRR F, G, H) <input type="checkbox"/> A11 - Depleted Below Dark Surface <input type="checkbox"/> A12 - Thick Dark Surface <input type="checkbox"/> S1 - Sandy Muck Mineral <input type="checkbox"/> S2 - 2.5 cm Mucky Peat or Peat (LRR G, H) 	<ul style="list-style-type: none"> <input type="checkbox"/> S3 - 5cm Mucky Peat or Peat (LRR F) <input type="checkbox"/> S4 - Sandy Gleyed Matrix <input type="checkbox"/> S5 - Sandy Redox <input type="checkbox"/> S6 - Stripped Matrix <input type="checkbox"/> F1 - Loamy Mucky Mineral <input type="checkbox"/> F2 Loamy Gleyed Matrix <input type="checkbox"/> F3 - Depleted Matrix <input type="checkbox"/> F6 - Redox Dark Surface <input type="checkbox"/> F7 - Depleted Dark Surface <input type="checkbox"/> F8 - Redox Depressions 	<ul style="list-style-type: none"> <input type="checkbox"/> F16 - High Plains Depressions (MLRA 72, 73 of LRR H) <input type="checkbox"/> A9 - 1cm Muck (LRR I, J) <input type="checkbox"/> A16 - Coast Prairie Redox (LRR F, G, H) <input type="checkbox"/> S7 - Dark Surface (LRR G) <input type="checkbox"/> F16 - High Plains Depressions (LRR H outside MLRA 72, 73) <input type="checkbox"/> F18 - Reduced Vertic <input type="checkbox"/> TF2 - Red Parent Material <input type="checkbox"/> TF12 - Very Shallow Dark Surface <input type="checkbox"/> Other (Explain in Remarks)
--	--	---

¹ Indicators of hydrophytic vegetation and wetland hydrology must be present, unless disturbed or problematic.

Restrictive Layer (If Observed) Type: N/A	Depth: N/A	Hydric Soil Present? <input type="checkbox"/> Yes <input checked="" type="checkbox"/> No
--	-------------------	---

Remarks: **The only applicable hydric soil indicator beyond 12" is "Thick Dark Surface (A12)," for which this sample point does not meet the requirements.**

Project/Site: **Harmony Solar Array** Wetland ID: **N/A** Sample Point **U9**
VEGETATION (Species identified in all uppercase are non-native species.)

Tree Stratum (Plot size: 30 ft radius)				
	Species Name	% Cover	Dominant	Ind. Status
1.	--	--	--	--
2.	--	--	--	--
3.	--	--	--	--
4.	--	--	--	--
5.	--	--	--	--
6.	--	--	--	--
7.	--	--	--	--
8.	--	--	--	--
9.	--	--	--	--
10.	--	--	--	--
Total Cover =		0		

Dominance Test Worksheet	
Number of Dominant Species that are OBL, FACW, or FAC:	<u>0</u> (A)
Total Number of Dominant Species Across All Strata:	<u>1</u> (B)
Percent of Dominant Species That Are OBL, FACW, or FAC:	<u>0.0%</u> (A/B)

Sapling/Shrub Stratum (Plot size: 15 ft radius)				
	Species Name	% Cover	Dominant	Ind. Status
1.	--	--	--	--
2.	--	--	--	--
3.	--	--	--	--
4.	--	--	--	--
5.	--	--	--	--
6.	--	--	--	--
7.	--	--	--	--
8.	--	--	--	--
9.	--	--	--	--
10.	--	--	--	--
Total Cover =		0		

Prevalence Index Worksheet	
Total % Cover of:	Multiply by:
OBL spp. <u>0</u>	x 1 = <u>0</u>
FACW spp. <u>0</u>	x 2 = <u>0</u>
FAC spp. <u>0</u>	x 3 = <u>0</u>
FACU spp. <u>0</u>	x 4 = <u>0</u>
UPL spp. <u>10</u>	x 5 = <u>50</u>
Total <u>10</u> (A)	<u>50</u> (B)
Prevalence Index = B/A = <u>5.000</u>	

Herb Stratum (Plot size: 5 ft radius)				
	Species Name	% Cover	Dominant	Ind. Status
1.	GLYCINE MAX	10	Y	UPL
2.	--	--	--	--
3.	--	--	--	--
4.	--	--	--	--
5.	--	--	--	--
6.	--	--	--	--
7.	--	--	--	--
8.	--	--	--	--
9.	--	--	--	--
10.	--	--	--	--
11.	--	--	--	--
12.	--	--	--	--
13.	--	--	--	--
14.	--	--	--	--
15.	--	--	--	--
Total Cover =		10		

Hydrophytic Vegetation Indicators:		
<input type="checkbox"/> Yes	<input checked="" type="checkbox"/> No	Rapid Test for Hydrophytic Vegetation
<input type="checkbox"/> Yes	<input checked="" type="checkbox"/> No	Dominance Test is > 50%
<input type="checkbox"/> Yes	<input checked="" type="checkbox"/> No	Prevalence Index is ≤ 3.0 *
<input type="checkbox"/> Yes	<input type="checkbox"/> No	Morphological Adaptations (Explain) *
<input type="checkbox"/> Yes	<input type="checkbox"/> No	Problem Hydrophytic Vegetation (Explain) *

* Indicators of hydric soil and wetland hydrology must be present, unless disturbed or problematic.

Woody Vine Stratum (Plot size: 30 ft radius)				
	Species Name	% Cover	Dominant	Ind. Status
1.	--	--	--	--
2.	--	--	--	--
3.	--	--	--	--
4.	--	--	--	--
5.	--	--	--	--
Total Cover =		0		

Definitions of Vegetation Strata:	
Tree	- Woody plants 3 in. (7.6cm) or more in diameter at breast height (DBH), regardless of height.
Sapling/Shrub	- Woody plants less than 3 in. DBH and greater than 3.28 ft. tall.
Herb	- All herbaceous (non-woody) plants, regardless of size, and woody plants less than 3.28 ft. tall.
Woody Vines	- All woody vines greater than 3.28 ft. in height.

 Remarks: **Agricultural soybean commodity successfully harvested.**

Hydrophytic Vegetation Present	<input type="checkbox"/> Yes	<input checked="" type="checkbox"/> No
---------------------------------------	------------------------------	--

Additional Remarks:

Sample point located in minor swale identified from aerial images and is part of the drainage feature crossing the section. The sample point is in a successfully cropped field, lacking hydrophytic, hydrologic, and hydric soil indicators. The sample point is not a wetland feature.

Project/Site: Harmony Solar Array		Stantec Project #: 193704812	Date: 10/20/16
Applicant: Harmony Solar ND LLC			County: Cass
Investigator #1: Joseph Sander		Investigator #2:	State: North Dakota
Soil Unit: I373A Kindred-Bearden silty clay loams	NWI Classification: None	Wetland ID: N/A	Sample Point: U10
Landform: Swailes, Flats	Local Relief: None	Community ID: Agricultural commodity	Section: 10
Slope (%): 0-2	Latitude: --	Longitude: --	Datum: NAD 83
Are climatic/hydrologic conditions on the site typical for this time of year? (If no, explain in remarks) <input checked="" type="checkbox"/> Yes <input type="checkbox"/> No		Are normal circumstances present? <input type="checkbox"/> Yes <input checked="" type="checkbox"/> No	
Are Vegetation <input checked="" type="checkbox"/> , Soil <input checked="" type="checkbox"/> , or Hydrology <input checked="" type="checkbox"/> significantly disturbed?		Are Vegetation <input type="checkbox"/> , Soil <input type="checkbox"/> , or Hydrology <input type="checkbox"/> naturally problematic? <input type="checkbox"/> Yes <input checked="" type="checkbox"/> No	
Township: 140N		Range: 51W Dir: --	

SUMMARY OF FINDINGS

Hydrophytic Vegetation Present? <input type="checkbox"/> Yes <input checked="" type="checkbox"/> No	Hydric Soils Present? <input type="checkbox"/> Yes <input checked="" type="checkbox"/> No
Wetland Hydrology Present? <input type="checkbox"/> Yes <input checked="" type="checkbox"/> No	Is This Sampling Point Within A Wetland? <input checked="" type="checkbox"/> Yes <input type="checkbox"/> No

Remarks: **Sample point is located in a successfully cropped area of an agricultural field subjected to frequent tilling.**

HYDROLOGY

Wetland Hydrology Indicators (Check here if indicators are not present):

<p><u>Primary:</u></p> <ul style="list-style-type: none"> <input type="checkbox"/> A1 - Surface Water <input type="checkbox"/> A2 - High Water Table <input type="checkbox"/> A3 - Saturation <input type="checkbox"/> B1 - Water Marks <input type="checkbox"/> B2 - Sediment Deposits <input type="checkbox"/> B3 - Drift Deposits <input type="checkbox"/> B4 - Algal Mat or Crust <input type="checkbox"/> B5 - Iron Deposits <input type="checkbox"/> B7 - Inundation Visible on Aerial Imagery <input type="checkbox"/> B9 - Water Stained Leaves 	<ul style="list-style-type: none"> <input type="checkbox"/> B11 - Salt Crust <input type="checkbox"/> B13 - Aquatic Invertebrates <input type="checkbox"/> C1 - Hydrogen Sulfide Odor <input type="checkbox"/> C2 - Dry-Season Water Table <input type="checkbox"/> C3 - Oxidized Rhizospheres on Living Roots (where not tilled) <input type="checkbox"/> C4 - Presence of Reduced Iron <input type="checkbox"/> C7 - Thin Muck Surface <input type="checkbox"/> Other (Explain in Remarks) 	<p><u>Secondary:</u></p> <ul style="list-style-type: none"> <input type="checkbox"/> B6 - Surface Soil Cracks <input type="checkbox"/> B8 - Sparsely Vegetated Concave Surface <input type="checkbox"/> B10 - Drainage Patterns <input type="checkbox"/> C3 - Oxidized Rhizospheres on Living Roots (where tilled) <input type="checkbox"/> C8 - Crayfish Burrows <input type="checkbox"/> C9 - Saturation Visible on Aerial Imagery <input type="checkbox"/> D2 - Geomorphic Position <input type="checkbox"/> D5 - FAC-Neutral Test <input type="checkbox"/> D7 - Frost-Heave Hummocks (LRR F)
---	--	---

Field Observations:

Surface Water Present? <input type="checkbox"/> Yes <input checked="" type="checkbox"/> No	Depth: 0 (in.)	Wetland Hydrology Present? <input type="checkbox"/> Yes <input checked="" type="checkbox"/> No
Water Table Present? <input type="checkbox"/> Yes <input checked="" type="checkbox"/> No	Depth: >24 (in.)	
Saturation Present? <input type="checkbox"/> Yes <input checked="" type="checkbox"/> No	Depth: >24 (in.)	

Describe Recorded Data (stream gauge, monitoring well, aerial photos, previous inspections), if available: **N/A**

Remarks: **Sample point is located near a stream bank with no relief in topography.**

SOILS

Map Unit Name: **I373A Kindred-Bearden silty clay loams** Series Drainage Class: **Somewhat poorly drained**

Taxonomy (Subgroup):

Profile Description (Describe to the depth needed to document the indicator or confirm the absence of indicators.) (Type: C=Concentration, D=Depletion, RM=Reduced Matrix, CS=Covered/Coated Sand Grains, Location: PL=Pore Lining, M=Matrix)

Top Depth	Bottom Depth	Horizon	Matrix			Redox Features				Texture (e.g. clay, sand, loam)	
			Color (Moist)	%		Color (Moist)	%	Type	Location		
0	8	Ap	10YR	2/1	100	--	None	--	--	--	silty clay loam
8	24	A	10YR	2/1	100	--	None	--	--	--	silty clay loam
--	--	--	--	--	--	--	--	--	--	--	--
--	--	--	--	--	--	--	--	--	--	--	--
--	--	--	--	--	--	--	--	--	--	--	--
--	--	--	--	--	--	--	--	--	--	--	--
--	--	--	--	--	--	--	--	--	--	--	--

NRCS Hydric Soil Field Indicators (check here if indicators are not present):

<ul style="list-style-type: none"> <input type="checkbox"/> A1 - Histosol <input type="checkbox"/> A2 - Histic Epipedon <input type="checkbox"/> A3 - Black Histic <input type="checkbox"/> A4 - Hydrogen Sulfide <input type="checkbox"/> A5 - Stratified Layers (LRR F) <input type="checkbox"/> A9 - 1 cm Muck (LRR F, G, H) <input type="checkbox"/> A11 - Depleted Below Dark Surface <input type="checkbox"/> A12 - Thick Dark Surface <input type="checkbox"/> S1 - Sandy Muck Mineral <input type="checkbox"/> S2 - 2.5 cm Mucky Peat or Peat (LRR G, H) 	<ul style="list-style-type: none"> <input type="checkbox"/> S3 - 5cm Mucky Peat or Peat (LRR F) <input type="checkbox"/> S4 - Sandy Gleyed Matrix <input type="checkbox"/> S5 - Sandy Redox <input type="checkbox"/> S6 - Stripped Matrix <input type="checkbox"/> F1 - Loamy Mucky Mineral <input type="checkbox"/> F2 Loamy Gleyed Matrix <input type="checkbox"/> F3 - Depleted Matrix <input type="checkbox"/> F6 - Redox Dark Surface <input type="checkbox"/> F7 - Depleted Dark Surface <input type="checkbox"/> F8 - Redox Depressions 	<ul style="list-style-type: none"> <input type="checkbox"/> F16 - High Plains Depressions (MLRA 72, 73 of LRR H) <input type="checkbox"/> A9 - 1cm Muck (LRR I, J) <input type="checkbox"/> A16 - Coast Prairie Redox (LRR F, G, H) <input type="checkbox"/> S7 - Dark Surface (LRR G) <input type="checkbox"/> F16 - High Plains Depressions (LRR H outside MLRA 72, 73) <input type="checkbox"/> F18 - Reduced Vertic <input type="checkbox"/> TF2 - Red Parent Material <input type="checkbox"/> TF12 - Very Shallow Dark Surface <input type="checkbox"/> Other (Explain in Remarks)
--	--	---

Restrictive Layer (If Observed) Type: **N/A** Depth: **N/A** **Hydric Soil Present?** Yes No

Remarks: **The only applicable hydric soil indicator beyond 12" is "Thick Dark Surface (A12), for which the sample point does not meet the requirements.**

¹ Indicators of hydrophytic vegetation and wetland hydrology must be present, unless disturbed or problematic.

Project/Site: **Harmony Solar Array** Wetland ID: **N/A** Sample Point **U10**
VEGETATION (Species identified in all uppercase are non-native species.)

Tree Stratum (Plot size: 30 ft radius)					Dominance Test Worksheet Number of Dominant Species that are OBL, FACW, or FAC: <u>0</u> (A) Total Number of Dominant Species Across All Strata: <u>1</u> (B) Percent of Dominant Species That Are OBL, FACW, or FAC: <u>0.0%</u> (A/B)																												
1.	Species Name	% Cover	Dominant	Ind. Status																													
2.	--	--	--	--																													
3.	--	--	--	--																													
4.	--	--	--	--																													
5.	--	--	--	--																													
6.	--	--	--	--																													
7.	--	--	--	--																													
8.	--	--	--	--																													
9.	--	--	--	--																													
Total Cover =		0																															
Sapling/Shrub Stratum (Plot size: 15 ft radius)					Prevalence Index Worksheet Total % Cover of: <table style="margin-left: 20px; border-collapse: collapse;"> <tr> <td>OBL spp.</td><td><u>0</u></td><td>x 1 =</td><td><u>0</u></td> </tr> <tr> <td>FACW spp.</td><td><u>0</u></td><td>x 2 =</td><td><u>0</u></td> </tr> <tr> <td>FAC spp.</td><td><u>0</u></td><td>x 3 =</td><td><u>0</u></td> </tr> <tr> <td>FACU spp.</td><td><u>0</u></td><td>x 4 =</td><td><u>0</u></td> </tr> <tr> <td>UPL spp.</td><td><u>20</u></td><td>x 5 =</td><td><u>100</u></td> </tr> <tr> <td colspan="2" style="text-align: right;">Total</td> <td><u>20</u> (A)</td> <td><u>100</u> (B)</td> </tr> <tr> <td colspan="4" style="text-align: right;">Prevalence Index = B/A = <u>5.000</u></td> </tr> </table>	OBL spp.	<u>0</u>	x 1 =	<u>0</u>	FACW spp.	<u>0</u>	x 2 =	<u>0</u>	FAC spp.	<u>0</u>	x 3 =	<u>0</u>	FACU spp.	<u>0</u>	x 4 =	<u>0</u>	UPL spp.	<u>20</u>	x 5 =	<u>100</u>	Total		<u>20</u> (A)	<u>100</u> (B)	Prevalence Index = B/A = <u>5.000</u>			
OBL spp.	<u>0</u>	x 1 =	<u>0</u>																														
FACW spp.	<u>0</u>	x 2 =	<u>0</u>																														
FAC spp.	<u>0</u>	x 3 =	<u>0</u>																														
FACU spp.	<u>0</u>	x 4 =	<u>0</u>																														
UPL spp.	<u>20</u>	x 5 =	<u>100</u>																														
Total		<u>20</u> (A)	<u>100</u> (B)																														
Prevalence Index = B/A = <u>5.000</u>																																	
1.	--	--	--	--																													
2.	--	--	--	--																													
3.	--	--	--	--																													
4.	--	--	--	--																													
5.	--	--	--	--																													
6.	--	--	--	--																													
7.	--	--	--	--																													
8.	--	--	--	--																													
9.	--	--	--	--																													
10.	--	--	--	--																													
Total Cover =		0																															
Herb Stratum (Plot size: 5 ft radius)					Hydrophytic Vegetation Indicators: <input type="checkbox"/> Yes <input checked="" type="checkbox"/> No Rapid Test for Hydrophytic Vegetation <input type="checkbox"/> Yes <input checked="" type="checkbox"/> No Dominance Test is > 50% <input type="checkbox"/> Yes <input checked="" type="checkbox"/> No Prevalence Index is ≤ 3.0 * <input type="checkbox"/> Yes <input type="checkbox"/> No Morphological Adaptations (Explain) * <input type="checkbox"/> Yes <input type="checkbox"/> No Problem Hydrophytic Vegetation (Explain) * * Indicators of hydric soil and wetland hydrology must be present, unless disturbed or problematic.																												
1.	ZEA MAYS	20	Y	UPL																													
2.	--	--	--	--																													
3.	--	--	--	--																													
4.	--	--	--	--																													
5.	--	--	--	--																													
6.	--	--	--	--																													
7.	--	--	--	--																													
8.	--	--	--	--																													
9.	--	--	--	--																													
10.	--	--	--	--																													
11.	--	--	--	--																													
12.	--	--	--	--																													
13.	--	--	--	--																													
14.	--	--	--	--																													
15.	--	--	--	--																													
Total Cover =		20																															
Woody Vine Stratum (Plot size: 30 ft radius)					Definitions of Vegetation Strata: <p style="margin-left: 40px;">Tree - Woody plants 3 in. (7.6cm) or more in diameter at breast height (DBH), regardless of height.</p> <p style="margin-left: 40px;">Sapling/Shrub - Woody plants less than 3 in. DBH and greater than 3.28 ft. tall.</p> <p style="margin-left: 40px;">Herb - All herbaceous (non-woody) plants, regardless of size, and woody plants less than 3.28 ft. tall.</p> <p style="margin-left: 40px;">Woody Vines - All woody vines greater than 3.28 ft. in height.</p>																												
1.	--	--	--	--																													
2.	--	--	--	--																													
3.	--	--	--	--																													
4.	--	--	--	--																													
Total Cover =		0																															
Remarks: Agricultural corn commodity successfully harvested.																																	

Additional Remarks:

Sample point located in an area just outside of a stream bank incision. The sample point is in a successfully cropped field, lacking hydrophytic, hydrologic, and hydric soil indicators. The sample point is not a wetland feature.

Project/Site: Harmony Solar Array		Stantec Project #: 193704812	Date: 10/20/16
Applicant: Harmony Solar ND LLC			County: Cass
Investigator #1: Joseph Sander		Investigator #2:	State: North Dakota
Soil Unit: I482A Overly-Bearden silt loams	NW1 Classification: None		Wetland ID: N/A
Landform: Flats	Local Relief: Concave		Sample Point: U11
Slope (%): 0-2	Latitude: --	Longitude: --	Datum: NAD 83
Are climatic/hydrologic conditions on the site typical for this time of year? (If no, explain in remarks) <input checked="" type="checkbox"/> Yes <input type="checkbox"/> No			Community ID: Agricultural commodity
Are Vegetation <input checked="" type="checkbox"/> , Soil <input checked="" type="checkbox"/> , or Hydrology <input checked="" type="checkbox"/> significantly disturbed?		Are normal circumstances present? <input type="checkbox"/> Yes <input checked="" type="checkbox"/> No	
Are Vegetation <input type="checkbox"/> , Soil <input type="checkbox"/> , or Hydrology <input type="checkbox"/> naturally problematic? <input type="checkbox"/> Yes <input checked="" type="checkbox"/> No		Township: 140N	
		Range: \$1W Dir: --	

SUMMARY OF FINDINGS

Hydrophytic Vegetation Present? <input type="checkbox"/> Yes <input checked="" type="checkbox"/> No	Hydric Soils Present? <input type="checkbox"/> Yes <input checked="" type="checkbox"/> No
Wetland Hydrology Present? <input type="checkbox"/> Yes <input checked="" type="checkbox"/> No	Is This Sampling Point Within A Wetland? <input checked="" type="checkbox"/> Yes <input type="checkbox"/> No

Remarks: **Sample point is located in a successfully cropped area of an agricultural field subjected to frequent tilling.**

HYDROLOGY

Wetland Hydrology Indicators (Check here if indicators are not present):

<p><u>Primary:</u></p> <ul style="list-style-type: none"> <input type="checkbox"/> A1 - Surface Water <input type="checkbox"/> A2 - High Water Table <input type="checkbox"/> A3 - Saturation <input type="checkbox"/> B1 - Water Marks <input type="checkbox"/> B2 - Sediment Deposits <input type="checkbox"/> B3 - Drift Deposits <input type="checkbox"/> B4 - Algal Mat or Crust <input type="checkbox"/> B5 - Iron Deposits <input type="checkbox"/> B7 - Inundation Visible on Aerial Imagery <input type="checkbox"/> B9 - Water Stained Leaves 	<ul style="list-style-type: none"> <input type="checkbox"/> B11 - Salt Crust <input type="checkbox"/> B13 - Aquatic Invertebrates <input type="checkbox"/> C1 - Hydrogen Sulfide Odor <input type="checkbox"/> C2 - Dry-Season Water Table <input type="checkbox"/> C3 - Oxidized Rhizospheres on Living Roots (where not tilled) <input type="checkbox"/> C4 - Presence of Reduced Iron <input type="checkbox"/> C7 - Thin Muck Surface <input type="checkbox"/> Other (Explain in Remarks) 	<p><u>Secondary:</u></p> <ul style="list-style-type: none"> <input type="checkbox"/> B6 - Surface Soil Cracks <input type="checkbox"/> B8 - Sparsely Vegetated Concave Surface <input type="checkbox"/> B10 - Drainage Patterns <input type="checkbox"/> C3 - Oxidized Rhizospheres on Living Roots (where tilled) <input type="checkbox"/> C8 - Crayfish Burrows <input type="checkbox"/> C9 - Saturation Visible on Aerial Imagery <input checked="" type="checkbox"/> D2 - Geomorphic Position <input type="checkbox"/> D5 - FAC-Neutral Test <input type="checkbox"/> D7 - Frost-Heave Hummocks (LRR F)
---	--	--

Field Observations:

Surface Water Present? <input type="checkbox"/> Yes <input checked="" type="checkbox"/> No	Depth: 0 (in.)	Wetland Hydrology Present? <input type="checkbox"/> Yes <input checked="" type="checkbox"/> No
Water Table Present? <input type="checkbox"/> Yes <input checked="" type="checkbox"/> No	Depth: >24 (in.)	
Saturation Present? <input type="checkbox"/> Yes <input checked="" type="checkbox"/> No	Depth: >24 (in.)	

Describe Recorded Data (stream gauge, monitoring well, aerial photos, previous inspections), if available: **N/A**

Remarks: **Sample point is located in a minor swale with 1% slope differentiation from surrounding topography.**

SOILS

Map Unit Name: **I482A Overly-Bearden silt loams** Series Drainage Class: **Moderately well drained**

Taxonomy (Subgroup):

Profile Description (Describe to the depth needed to document the indicator or confirm the absence of indicators.) (Type: C=Concentration, D=Depletion, RM=Reduced Matrix, CS=Covered/Coated Sand Grains, Location: PL=Pore Lining, M=Matrix)

Top Depth	Bottom Depth	Horizon	Matrix			Redox Features				Texture (e.g. clay, sand, loam)	
			Color (Moist)	%		Color (Moist)	%	Type	Location		
0	8	Ap	10YR	2/1	100	--	None	--	--	--	silt loam
8	24	A	10YR	2/1	100	--	None	--	--	--	silt loam
--	--	--	--	--	--	--	--	--	--	--	--
--	--	--	--	--	--	--	--	--	--	--	--
--	--	--	--	--	--	--	--	--	--	--	--
--	--	--	--	--	--	--	--	--	--	--	--
--	--	--	--	--	--	--	--	--	--	--	--

NRCS Hydric Soil Field Indicators (check here if indicators are not present):

<ul style="list-style-type: none"> <input type="checkbox"/> A1 - Histosol <input type="checkbox"/> A2 - Histic Epipedon <input type="checkbox"/> A3 - Black Histic <input type="checkbox"/> A4 - Hydrogen Sulfide <input type="checkbox"/> A5 - Stratified Layers (LRR F) <input type="checkbox"/> A9 - 1 cm Muck (LRR F, G, H) <input type="checkbox"/> A11 - Depleted Below Dark Surface <input type="checkbox"/> A12 - Thick Dark Surface <input type="checkbox"/> S1 - Sandy Muck Mineral <input type="checkbox"/> S2 - 2.5 cm Mucky Peat or Peat (LRR G, H) 	<ul style="list-style-type: none"> <input type="checkbox"/> S3 - 5cm Mucky Peat or Peat (LRR F) <input type="checkbox"/> S4 - Sandy Gleyed Matrix <input type="checkbox"/> S5 - Sandy Redox <input type="checkbox"/> S6 - Stripped Matrix <input type="checkbox"/> F1 - Loamy Mucky Mineral <input type="checkbox"/> F2 Loamy Gleyed Matrix <input type="checkbox"/> F3 - Depleted Matrix <input type="checkbox"/> F6 - Redox Dark Surface <input type="checkbox"/> F7 - Depleted Dark Surface <input type="checkbox"/> F8 - Redox Depressions 	<p>Indicators for Problematic Soils¹</p> <ul style="list-style-type: none"> <input type="checkbox"/> F16 - High Plains Depressions (MLRA 72, 73 of LRR H) <input type="checkbox"/> A9 - 1cm Muck (LRR I, J) <input type="checkbox"/> A16 - Coast Prairie Redox (LRR F, G, H) <input type="checkbox"/> S7 - Dark Surface (LRR G) <input type="checkbox"/> F16 - High Plains Depressions (LRR H outside MLRA 72, 73) <input type="checkbox"/> F18 - Reduced Vertic <input type="checkbox"/> TF2 - Red Parent Material <input type="checkbox"/> TF12 - Very Shallow Dark Surface <input type="checkbox"/> Other (Explain in Remarks)
--	--	--

Restrictive Layer (If Observed) Type: **N/A** Depth: **N/A** **Hydric Soil Present?** Yes No

Remarks: **The only applicable hydric soil indicator beyond 12" is "Thick Dark Surface (A12), for which the sample point does not meet the requirements.**

¹ Indicators of hydrophytic vegetation and wetland hydrology must be present, unless disturbed or problematic.

Project/Site: **Harmony Solar Array** Wetland ID: **N/A** Sample Point **U11**

VEGETATION (Species identified in all uppercase are non-native species.)				
Tree Stratum (Plot size: 30 ft radius)				
	<u>Species Name</u>	% Cover	Dominant	Ind. Status
1.	--	--	--	--
2.	--	--	--	--
3.	--	--	--	--
4.	--	--	--	--
5.	--	--	--	--
6.	--	--	--	--
7.	--	--	--	--
8.	--	--	--	--
9.	--	--	--	--
10.	--	--	--	--
Total Cover =		0		
Sapling/Shrub Stratum (Plot size: 15 ft radius)				
1.	--	--	--	--
2.	--	--	--	--
3.	--	--	--	--
4.	--	--	--	--
5.	--	--	--	--
6.	--	--	--	--
7.	--	--	--	--
8.	--	--	--	--
9.	--	--	--	--
10.	--	--	--	--
Total Cover =		0		
Herb Stratum (Plot size: 5 ft radius)				
1.	ZEA MAYS	10	Y	UPL
2.	--	--	--	--
3.	--	--	--	--
4.	--	--	--	--
5.	--	--	--	--
6.	--	--	--	--
7.	--	--	--	--
8.	--	--	--	--
9.	--	--	--	--
10.	--	--	--	--
11.	--	--	--	--
12.	--	--	--	--
13.	--	--	--	--
14.	--	--	--	--
15.	--	--	--	--
Total Cover =		10		
Woody Vine Stratum (Plot size: 30 ft radius)				
1.	--	--	--	--
2.	--	--	--	--
3.	--	--	--	--
4.	--	--	--	--
5.	--	--	--	--
Total Cover =		0		
Dominance Test Worksheet				
Number of Dominant Species that are OBL, FACW, or FAC: <u>0</u> (A)				
Total Number of Dominant Species Across All Strata: <u>1</u> (B)				
Percent of Dominant Species That Are OBL, FACW, or FAC: <u>0.0%</u> (A/B)				
Prevalence Index Worksheet				
Total % Cover of:		Multiply by:		
OBL spp.	<u>0</u>	x 1 =	<u>0</u>	
FACW spp.	<u>0</u>	x 2 =	<u>0</u>	
FAC spp.	<u>0</u>	x 3 =	<u>0</u>	
FACU spp.	<u>0</u>	x 4 =	<u>0</u>	
UPL spp.	<u>10</u>	x 5 =	<u>50</u>	
Total		<u>10</u> (A)	<u>50</u> (B)	
Prevalence Index = B/A = <u>5.000</u>				
Hydrophytic Vegetation Indicators:				
<input type="checkbox"/> Yes	<input checked="" type="checkbox"/> No	Rapid Test for Hydrophytic Vegetation		
<input type="checkbox"/> Yes	<input checked="" type="checkbox"/> No	Dominance Test is > 50%		
<input type="checkbox"/> Yes	<input checked="" type="checkbox"/> No	Prevalence Index is ≤ 3.0 *		
<input type="checkbox"/> Yes	<input type="checkbox"/> No	Morphological Adaptations (Explain) *		
<input type="checkbox"/> Yes	<input type="checkbox"/> No	Problem Hydrophytic Vegetation (Explain) *		
* Indicators of hydric soil and wetland hydrology must be present, unless disturbed or problematic.				
Definitions of Vegetation Strata:				
Tree - Woody plants 3 in. (7.6cm) or more in diameter at breast height (DBH), regardless of height.				
Sapling/Shrub - Woody plants less than 3 in. DBH and greater than 3.28 ft. tall.				
Herb - All herbaceous (non-woody) plants, regardless of size, and woody plants less than 3.28 ft. tall.				
Woody Vines - All woody vines greater than 3.28 ft. in height.				
Hydrophytic Vegetation Present <input type="checkbox"/> Yes <input checked="" type="checkbox"/> No				
Remarks: Agricultural corn commodity successfully harvested.				

Additional Remarks:

Sample point located in an area identified as a wet signature from aerial imagery. The sample point is in a successfully cropped field, lacking hydrophytic, hydrologic, and hydric soil indicators. The sample point is not a wetland feature.

Project/Site: Harmony Solar Array		Stantec Project #: 193704812	Date: 10/20/16
Applicant: Harmony Solar ND LLC			County: Cass
Investigator #1: Joseph Sander		Investigator #2:	State: North Dakota
Soil Unit: 1371A Bearden-Kindred silty clay loams	NWI Classification: None	Wetland ID: N/A	Sample Point: U12
Landform: Flats	Local Relief: Concave	Community ID: Agricultural commodity	Section: 10
Slope (%): 0-2	Latitude: --	Longitude: --	Datum: NAD 83
Are climatic/hydrologic conditions on the site typical for this time of year? (If no, explain in remarks) <input checked="" type="checkbox"/> Yes <input type="checkbox"/> No		Are normal circumstances present? <input type="checkbox"/> Yes <input checked="" type="checkbox"/> No	
Are Vegetation <input checked="" type="checkbox"/> , Soil <input checked="" type="checkbox"/> , or Hydrology <input checked="" type="checkbox"/> significantly disturbed?		Are Vegetation <input type="checkbox"/> , Soil <input type="checkbox"/> , or Hydrology <input type="checkbox"/> naturally problematic? <input type="checkbox"/> Yes <input checked="" type="checkbox"/> No	
Township: 140N		Range: 51W Dir: --	

SUMMARY OF FINDINGS

Hydrophytic Vegetation Present? <input type="checkbox"/> Yes <input checked="" type="checkbox"/> No	Hydric Soils Present? <input type="checkbox"/> Yes <input checked="" type="checkbox"/> No
Wetland Hydrology Present? <input type="checkbox"/> Yes <input checked="" type="checkbox"/> No	Is This Sampling Point Within A Wetland? <input checked="" type="checkbox"/> Yes <input type="checkbox"/> No

Remarks: **Sample point is located in a successfully cropped area of an agricultural field subjected to frequent tilling.**

HYDROLOGY

Wetland Hydrology Indicators (Check here if indicators are not present):

<p><u>Primary:</u></p> <ul style="list-style-type: none"> <input type="checkbox"/> A1 - Surface Water <input type="checkbox"/> A2 - High Water Table <input type="checkbox"/> A3 - Saturation <input type="checkbox"/> B1 - Water Marks <input type="checkbox"/> B2 - Sediment Deposits <input type="checkbox"/> B3 - Drift Deposits <input type="checkbox"/> B4 - Algal Mat or Crust <input type="checkbox"/> B5 - Iron Deposits <input type="checkbox"/> B7 - Inundation Visible on Aerial Imagery <input type="checkbox"/> B9 - Water Stained Leaves 	<ul style="list-style-type: none"> <input type="checkbox"/> B11 - Salt Crust <input type="checkbox"/> B13 - Aquatic Invertebrates <input type="checkbox"/> C1 - Hydrogen Sulfide Odor <input type="checkbox"/> C2 - Dry-Season Water Table <input type="checkbox"/> C3 - Oxidized Rhizospheres on Living Roots (where not tilled) <input type="checkbox"/> C4 - Presence of Reduced Iron <input type="checkbox"/> C7 - Thin Muck Surface <input type="checkbox"/> Other (Explain in Remarks) 	<p><u>Secondary:</u></p> <ul style="list-style-type: none"> <input type="checkbox"/> B6 - Surface Soil Cracks <input type="checkbox"/> B8 - Sparsely Vegetated Concave Surface <input type="checkbox"/> B10 - Drainage Patterns <input type="checkbox"/> C3 - Oxidized Rhizospheres on Living Roots (where tilled) <input type="checkbox"/> C8 - Crayfish Burrows <input type="checkbox"/> C9 - Saturation Visible on Aerial Imagery <input checked="" type="checkbox"/> D2 - Geomorphic Position <input type="checkbox"/> D5 - FAC-Neutral Test <input type="checkbox"/> D7 - Frost-Heave Hummocks (LRR F)
---	--	--

Field Observations:

Surface Water Present? <input type="checkbox"/> Yes <input checked="" type="checkbox"/> No	Depth: 0 (in.)	Wetland Hydrology Present? <input type="checkbox"/> Yes <input checked="" type="checkbox"/> No
Water Table Present? <input type="checkbox"/> Yes <input checked="" type="checkbox"/> No	Depth: >24 (in.)	
Saturation Present? <input type="checkbox"/> Yes <input checked="" type="checkbox"/> No	Depth: >24 (in.)	

Describe Recorded Data (stream gauge, monitoring well, aerial photos, previous inspections), if available: **N/A**

Remarks: **Sample point is located in a minor swale with 1% slope differentiation from surrounding topography.**

SOILS

Map Unit Name: **1371A Bearden-Kindred silty clay loams** Series Drainage Class: **Somewhat poorly drained**

Taxonomy (Subgroup):

Profile Description (Describe to the depth needed to document the indicator or confirm the absence of indicators.) (Type: C=Concentration, D=Depletion, RM=Reduced Matrix, CS=Covered/Coated Sand Grains, Location: PL=Pore Lining, M=Matrix)

Top Depth	Bottom Depth	Horizon	Matrix			Redox Features				Texture (e.g. clay, sand, loam)	
			Color (Moist)	%		Color (Moist)	%	Type	Location		
0	8	Ap	10YR	2/1	100	--	None	--	--	--	silty clay loam
8	24	A	10YR	2/1	100	--	None	--	--	--	silty clay loam
--	--	--	--	--	--	--	--	--	--	--	--
--	--	--	--	--	--	--	--	--	--	--	--
--	--	--	--	--	--	--	--	--	--	--	--
--	--	--	--	--	--	--	--	--	--	--	--
--	--	--	--	--	--	--	--	--	--	--	--

NRCS Hydric Soil Field Indicators (check here if indicators are not present):

<ul style="list-style-type: none"> <input type="checkbox"/> A1 - Histosol <input type="checkbox"/> A2 - Histic Epipedon <input type="checkbox"/> A3 - Black Histic <input type="checkbox"/> A4 - Hydrogen Sulfide <input type="checkbox"/> A5 - Stratified Layers (LRR F) <input type="checkbox"/> A9 - 1 cm Muck (LRR F, G, H) <input type="checkbox"/> A11 - Depleted Below Dark Surface <input type="checkbox"/> A12 - Thick Dark Surface <input type="checkbox"/> S1 - Sandy Muck Mineral <input type="checkbox"/> S2 - 2.5 cm Mucky Peat or Peat (LRR G, H) 	<ul style="list-style-type: none"> <input type="checkbox"/> S3 - 5cm Mucky Peat or Peat (LRR F) <input type="checkbox"/> S4 - Sandy Gleyed Matrix <input type="checkbox"/> S5 - Sandy Redox <input type="checkbox"/> S6 - Stripped Matrix <input type="checkbox"/> F1 - Loamy Mucky Mineral <input type="checkbox"/> F2 Loamy Gleyed Matrix <input type="checkbox"/> F3 - Depleted Matrix <input type="checkbox"/> F6 - Redox Dark Surface <input type="checkbox"/> F7 - Depleted Dark Surface <input type="checkbox"/> F8 - Redox Depressions 	<ul style="list-style-type: none"> <input type="checkbox"/> F16 - High Plains Depressions (MLRA 72, 73 of LRR H) <input type="checkbox"/> A9 - 1cm Muck (LRR I, J) <input type="checkbox"/> A16 - Coast Prairie Redox (LRR F, G, H) <input type="checkbox"/> S7 - Dark Surface (LRR G) <input type="checkbox"/> F16 - High Plains Depressions (LRR H outside MLRA 72, 73) <input type="checkbox"/> F18 - Reduced Vertic <input type="checkbox"/> TF2 - Red Parent Material <input type="checkbox"/> TF12 - Very Shallow Dark Surface <input type="checkbox"/> Other (Explain in Remarks)
--	--	---

¹ Indicators of hydrophytic vegetation and wetland hydrology must be present, unless disturbed or problematic.

Restrictive Layer (If Observed) Type: N/A	Depth: N/A	Hydric Soil Present? <input type="checkbox"/> Yes <input checked="" type="checkbox"/> No
--	-------------------	---

Remarks: **The only applicable hydric soil indicator beyond 12" is "Thick Dark Surface (A12), for which the sample point does not meet the requirements.**

Project/Site: **Harmony Solar Array** Wetland ID: **N/A** Sample Point **U12**
VEGETATION (Species identified in all uppercase are non-native species.)

Tree Stratum (Plot size: 30 ft radius)				
	Species Name	% Cover	Dominant	Ind. Status
1.	--	--	--	--
2.	--	--	--	--
3.	--	--	--	--
4.	--	--	--	--
5.	--	--	--	--
6.	--	--	--	--
7.	--	--	--	--
8.	--	--	--	--
9.	--	--	--	--
10.	--	--	--	--
Total Cover =		0		

Dominance Test Worksheet	
Number of Dominant Species that are OBL, FACW, or FAC:	<u>0</u> (A)
Total Number of Dominant Species Across All Strata:	<u>1</u> (B)
Percent of Dominant Species That Are OBL, FACW, or FAC:	<u>0.0%</u> (A/B)

Sapling/Shrub Stratum (Plot size: 15 ft radius)				
	Species Name	% Cover	Dominant	Ind. Status
1.	--	--	--	--
2.	--	--	--	--
3.	--	--	--	--
4.	--	--	--	--
5.	--	--	--	--
6.	--	--	--	--
7.	--	--	--	--
8.	--	--	--	--
9.	--	--	--	--
10.	--	--	--	--
Total Cover =		0		

Prevalence Index Worksheet	
Total % Cover of:	Multiply by:
OBL spp. <u>0</u>	x 1 = <u>0</u>
FACW spp. <u>0</u>	x 2 = <u>0</u>
FAC spp. <u>0</u>	x 3 = <u>0</u>
FACU spp. <u>0</u>	x 4 = <u>0</u>
UPL spp. <u>20</u>	x 5 = <u>100</u>
Total <u>20</u> (A)	<u>100</u> (B)
Prevalence Index = B/A = <u>5.000</u>	

Herb Stratum (Plot size: 5 ft radius)				
	Species Name	% Cover	Dominant	Ind. Status
1.	ZEA MAYS	20	Y	UPL
2.	--	--	--	--
3.	--	--	--	--
4.	--	--	--	--
5.	--	--	--	--
6.	--	--	--	--
7.	--	--	--	--
8.	--	--	--	--
9.	--	--	--	--
10.	--	--	--	--
11.	--	--	--	--
12.	--	--	--	--
13.	--	--	--	--
14.	--	--	--	--
15.	--	--	--	--
Total Cover =		20		

Hydrophytic Vegetation Indicators:		
<input type="checkbox"/> Yes	<input checked="" type="checkbox"/> No	Rapid Test for Hydrophytic Vegetation
<input type="checkbox"/> Yes	<input checked="" type="checkbox"/> No	Dominance Test is > 50%
<input type="checkbox"/> Yes	<input checked="" type="checkbox"/> No	Prevalence Index is ≤ 3.0 *
<input type="checkbox"/> Yes	<input type="checkbox"/> No	Morphological Adaptations (Explain) *
<input type="checkbox"/> Yes	<input type="checkbox"/> No	Problem Hydrophytic Vegetation (Explain) *

* Indicators of hydric soil and wetland hydrology must be present, unless disturbed or problematic.

Woody Vine Stratum (Plot size: 30 ft radius)				
	Species Name	% Cover	Dominant	Ind. Status
1.	--	--	--	--
2.	--	--	--	--
3.	--	--	--	--
4.	--	--	--	--
5.	--	--	--	--
Total Cover =		0		

Definitions of Vegetation Strata:	
Tree	Woody plants 3 in. (7.6cm) or more in diameter at breast height (DBH), regardless of height.
Sapling/Shrub	Woody plants less than 3 in. DBH and greater than 3.28 ft. tall.
Herb	All herbaceous (non-woody) plants, regardless of size, and woody plants less than 3.28 ft. tall.
Woody Vines	All woody vines greater than 3.28 ft. in height.

 Remarks: **Agricultural corn commodity successfully harvested.**

Hydrophytic Vegetation Present	<input type="checkbox"/> Yes	<input checked="" type="checkbox"/> No
---------------------------------------	------------------------------	--

Additional Remarks:

Sample point located in an area identified as a wet signature from aerial imagery. The sample point is in a successfully cropped field, lacking hydrophytic, hydrologic, and hydric soil indicators. The sample point is not a wetland feature.

Project/Site: Harmony Solar Array		Stantec Project #: 193704812	Date: 10/20/16
Applicant: Harmony Solar ND LLC			County: Cass
Investigator #1: Joseph Sander		Investigator #2:	State: North Dakota
Soil Unit: I229A Fargo silty clay	NW1 Classification: None		Wetland ID: N/A
Landform: Flats	Local Relief: Concave		Sample Point: U13
Slope (%): 0-1	Latitude: --	Longitude: --	Datum: NAD 83
Are climatic/hydrologic conditions on the site typical for this time of year? (If no, explain in remarks) <input checked="" type="checkbox"/> Yes <input type="checkbox"/> No			Community ID: Agricultural commodity
Are Vegetation <input checked="" type="checkbox"/> , Soil <input checked="" type="checkbox"/> , or Hydrology <input checked="" type="checkbox"/> significantly disturbed?		Are normal circumstances present? <input type="checkbox"/> Yes <input checked="" type="checkbox"/> No	
Are Vegetation <input type="checkbox"/> , Soil <input type="checkbox"/> , or Hydrology <input type="checkbox"/> naturally problematic? <input type="checkbox"/> Yes <input checked="" type="checkbox"/> No		Township: 140N	
		Range: 51W Dir: --	

SUMMARY OF FINDINGS

Hydrophytic Vegetation Present? <input type="checkbox"/> Yes <input checked="" type="checkbox"/> No	Hydric Soils Present? <input type="checkbox"/> Yes <input checked="" type="checkbox"/> No
Wetland Hydrology Present? <input type="checkbox"/> Yes <input checked="" type="checkbox"/> No	Is This Sampling Point Within A Wetland? <input checked="" type="checkbox"/> Yes <input type="checkbox"/> No

Remarks: **Sample point is located in a successfully cropped area of an agricultural field subjected to frequent tilling.**

HYDROLOGY

Wetland Hydrology Indicators (Check here if indicators are not present):

<p><u>Primary:</u></p> <ul style="list-style-type: none"> <input type="checkbox"/> A1 - Surface Water <input type="checkbox"/> A2 - High Water Table <input type="checkbox"/> A3 - Saturation <input type="checkbox"/> B1 - Water Marks <input type="checkbox"/> B2 - Sediment Deposits <input type="checkbox"/> B3 - Drift Deposits <input type="checkbox"/> B4 - Algal Mat or Crust <input type="checkbox"/> B5 - Iron Deposits <input type="checkbox"/> B7 - Inundation Visible on Aerial Imagery <input type="checkbox"/> B9 - Water Stained Leaves 	<ul style="list-style-type: none"> <input checked="" type="checkbox"/> B11 - Salt Crust <input type="checkbox"/> B13 - Aquatic Invertebrates <input type="checkbox"/> C1 - Hydrogen Sulfide Odor <input type="checkbox"/> C2 - Dry-Season Water Table <input type="checkbox"/> C3 - Oxidized Rhizospheres on Living Roots (where not tilled) <input type="checkbox"/> C4 - Presence of Reduced Iron <input type="checkbox"/> C7 - Thin Muck Surface <input type="checkbox"/> Other (Explain in Remarks) 	<p><u>Secondary:</u></p> <ul style="list-style-type: none"> <input type="checkbox"/> B6 - Surface Soil Cracks <input type="checkbox"/> B8 - Sparsely Vegetated Concave Surface <input type="checkbox"/> B10 - Drainage Patterns <input type="checkbox"/> C3 - Oxidized Rhizospheres on Living Roots (where tilled) <input type="checkbox"/> C8 - Crayfish Burrows <input type="checkbox"/> C9 - Saturation Visible on Aerial Imagery <input checked="" type="checkbox"/> D2 - Geomorphic Position <input type="checkbox"/> D5 - FAC-Neutral Test <input type="checkbox"/> D7 - Frost-Heave Hummocks (LRR F)
---	---	--

Field Observations:

Surface Water Present? <input type="checkbox"/> Yes <input checked="" type="checkbox"/> No	Depth: 0 (in.)	Wetland Hydrology Present? <input type="checkbox"/> Yes <input checked="" type="checkbox"/> No
Water Table Present? <input type="checkbox"/> Yes <input checked="" type="checkbox"/> No	Depth: >24 (in.)	
Saturation Present? <input type="checkbox"/> Yes <input checked="" type="checkbox"/> No	Depth: >24 (in.)	

Describe Recorded Data (stream gauge, monitoring well, aerial photos, previous inspections), if available: **N/A**

Remarks: **Sample point is located in a minor depression with 1% slope differentiation from surrounding topography. Salt crust suggests water ponding and evaporation occurs in the area, however; not long enough to create hydric conditions.**

SOILS

Map Unit Name: **I229A Fargo silty clay** Series Drainage Class: **Poorly drained**

Taxonomy (Subgroup):

Profile Description (Describe to the depth needed to document the indicator or confirm the absence of indicators.) (Type: C=Concentration, D=Depletion, RM=Reduced Matrix, CS=Covered/Coated Sand Grains, Location: PL=Pore Lining, M=Matrix)

Top Depth	Bottom Depth	Horizon	Matrix			Redox Features				Texture (e.g. clay, sand, loam)	
			Color (Moist)	%		Color (Moist)	%	Type	Location		
0	8	Ap	10YR	2/1	100	--	None	--	--	--	silty clay
8	20	A	10YR	3/1	100	--	None	--	--	--	silty clay
20	24	B	10YR	3/1	100	--	None	--	--	--	silty clay
--	--	--	--	--	--	--	--	--	--	--	--
--	--	--	--	--	--	--	--	--	--	--	--
--	--	--	--	--	--	--	--	--	--	--	--
--	--	--	--	--	--	--	--	--	--	--	--

NRCS Hydric Soil Field Indicators (check here if indicators are not present):

<ul style="list-style-type: none"> <input type="checkbox"/> A1 - Histosol <input type="checkbox"/> A2 - Histic Epipedon <input type="checkbox"/> A3 - Black Histic <input type="checkbox"/> A4 - Hydrogen Sulfide <input type="checkbox"/> A5 - Stratified Layers (LRR F) <input type="checkbox"/> A9 - 1 cm Muck (LRR F, G, H) <input type="checkbox"/> A11 - Depleted Below Dark Surface <input type="checkbox"/> A12 - Thick Dark Surface <input type="checkbox"/> S1 - Sandy Muck Mineral <input type="checkbox"/> S2 - 2.5 cm Mucky Peat or Peat (LRR G, H) 	<ul style="list-style-type: none"> <input type="checkbox"/> S3 - 5cm Mucky Peat or Peat (LRR F) <input type="checkbox"/> S4 - Sandy Gleyed Matrix <input type="checkbox"/> S5 - Sandy Redox <input type="checkbox"/> S6 - Stripped Matrix <input type="checkbox"/> F1 - Loamy Mucky Mineral <input type="checkbox"/> F2 Loamy Gleyed Matrix <input type="checkbox"/> F3 - Depleted Matrix <input type="checkbox"/> F6 - Redox Dark Surface <input type="checkbox"/> F7 - Depleted Dark Surface <input type="checkbox"/> F8 - Redox Depressions 	<ul style="list-style-type: none"> <input type="checkbox"/> F16 - High Plains Depressions (MLRA 72, 73 of LRR H) <input type="checkbox"/> A9 - 1cm Muck (LRR I, J) <input type="checkbox"/> A16 - Coast Prairie Redox (LRR F, G, H) <input type="checkbox"/> S7 - Dark Surface (LRR G) <input type="checkbox"/> F16 - High Plains Depressions (LRR H outside MLRA 72, 73) <input type="checkbox"/> F18 - Reduced Vertic <input type="checkbox"/> TF2 - Red Parent Material <input type="checkbox"/> TF12 - Very Shallow Dark Surface <input type="checkbox"/> Other (Explain in Remarks)
--	--	---

¹ Indicators of hydrophytic vegetation and wetland hydrology must be present, unless disturbed or problematic.

Restrictive Layer (If Observed) Type: **N/A** Depth: **N/A** **Hydric Soil Present?** Yes No

Remarks: **The only applicable hydric soil indicator beyond 12" is "Thick Dark Surface (A12), for which the sample point does not meet the requirements.**

Project/Site: **Harmony Solar Array** Wetland ID: **N/A** Sample Point **U13**
VEGETATION (Species identified in all uppercase are non-native species.)

Tree Stratum (Plot size: 30 ft radius)					Dominance Test Worksheet Number of Dominant Species that are OBL, FACW, or FAC: <u>0</u> (A) Total Number of Dominant Species Across All Strata: <u>1</u> (B) Percent of Dominant Species That Are OBL, FACW, or FAC: <u>0.0%</u> (A/B)																												
1.	Species Name	% Cover	Dominant	Ind. Status																													
2.	--	--	--	--																													
3.	--	--	--	--																													
4.	--	--	--	--																													
5.	--	--	--	--																													
6.	--	--	--	--																													
7.	--	--	--	--																													
8.	--	--	--	--																													
9.	--	--	--	--																													
Total Cover =		0																															
Sapling/Shrub Stratum (Plot size: 15 ft radius)					Prevalence Index Worksheet Total % Cover of: <table style="margin-left: 20px; border-collapse: collapse;"> <tr> <td>OBL spp.</td><td><u>0</u></td><td>x 1 =</td><td><u>0</u></td> </tr> <tr> <td>FACW spp.</td><td><u>0</u></td><td>x 2 =</td><td><u>0</u></td> </tr> <tr> <td>FAC spp.</td><td><u>0</u></td><td>x 3 =</td><td><u>0</u></td> </tr> <tr> <td>FACU spp.</td><td><u>0</u></td><td>x 4 =</td><td><u>0</u></td> </tr> <tr> <td>UPL spp.</td><td><u>15</u></td><td>x 5 =</td><td><u>75</u></td> </tr> <tr> <td colspan="2" style="text-align: right;">Total</td> <td><u>15</u> (A)</td> <td><u>75</u> (B)</td> </tr> <tr> <td colspan="4" style="text-align: right;">Prevalence Index = B/A = <u>5.000</u></td> </tr> </table>	OBL spp.	<u>0</u>	x 1 =	<u>0</u>	FACW spp.	<u>0</u>	x 2 =	<u>0</u>	FAC spp.	<u>0</u>	x 3 =	<u>0</u>	FACU spp.	<u>0</u>	x 4 =	<u>0</u>	UPL spp.	<u>15</u>	x 5 =	<u>75</u>	Total		<u>15</u> (A)	<u>75</u> (B)	Prevalence Index = B/A = <u>5.000</u>			
OBL spp.	<u>0</u>	x 1 =	<u>0</u>																														
FACW spp.	<u>0</u>	x 2 =	<u>0</u>																														
FAC spp.	<u>0</u>	x 3 =	<u>0</u>																														
FACU spp.	<u>0</u>	x 4 =	<u>0</u>																														
UPL spp.	<u>15</u>	x 5 =	<u>75</u>																														
Total		<u>15</u> (A)	<u>75</u> (B)																														
Prevalence Index = B/A = <u>5.000</u>																																	
1.	Species Name	% Cover	Dominant	Ind. Status																													
2.	--	--	--	--																													
3.	--	--	--	--																													
4.	--	--	--	--																													
5.	--	--	--	--																													
6.	--	--	--	--																													
7.	--	--	--	--																													
8.	--	--	--	--																													
9.	--	--	--	--																													
10.	--	--	--	--																													
Total Cover =		0																															
Herb Stratum (Plot size: 5 ft radius)					Hydrophytic Vegetation Indicators: <input type="checkbox"/> Yes <input checked="" type="checkbox"/> No Rapid Test for Hydrophytic Vegetation <input type="checkbox"/> Yes <input checked="" type="checkbox"/> No Dominance Test is > 50% <input type="checkbox"/> Yes <input checked="" type="checkbox"/> No Prevalence Index is ≤ 3.0 * <input type="checkbox"/> Yes <input type="checkbox"/> No Morphological Adaptations (Explain) * <input type="checkbox"/> Yes <input type="checkbox"/> No Problem Hydrophytic Vegetation (Explain) * * Indicators of hydric soil and wetland hydrology must be present, unless disturbed or problematic.																												
1.	Species Name	% Cover	Dominant	Ind. Status																													
2.	ZEA MAYS	15	Y	UPL																													
3.	--	--	--	--																													
4.	--	--	--	--																													
5.	--	--	--	--																													
6.	--	--	--	--																													
7.	--	--	--	--																													
8.	--	--	--	--																													
9.	--	--	--	--																													
10.	--	--	--	--																													
11.	--	--	--	--																													
12.	--	--	--	--																													
13.	--	--	--	--																													
14.	--	--	--	--																													
15.	--	--	--	--																													
Total Cover =		15																															
Woody Vine Stratum (Plot size: 30 ft radius)					Definitions of Vegetation Strata: <p>Tree - Woody plants 3 in. (7.6cm) or more in diameter at breast height (DBH), regardless of height.</p> <p>Sapling/Shrub - Woody plants less than 3 in. DBH and greater than 3.28 ft. tall.</p> <p>Herb - All herbaceous (non-woody) plants, regardless of size, and woody plants less than 3.28 ft. tall.</p> <p>Woody Vines - All woody vines greater than 3.28 ft. in height.</p>																												
1.	Species Name	% Cover	Dominant	Ind. Status																													
2.	--	--	--	--																													
3.	--	--	--	--																													
4.	--	--	--	--																													
5.	--	--	--	--																													
Total Cover =		0																															
Remarks: Agricultural corn commodity successfully harvested.																																	

Additional Remarks:

Sample point located in an area identified as a wet signature from aerial imagery. The sample point is in a successfully cropped field, lacking hydrophytic and hydric soil indicators. Hydrologic indications of ponding water exist, however; not long enough to create hydric soils. The sample point is not a wetland feature.

Project/Site: Harmony Solar Array		Stantec Project #: 193704812	Date: 10/20/16
Applicant: Harmony Solar ND LLC			County: Cass
Investigator #1: Joseph Sander		Investigator #2:	State: North Dakota
Soil Unit: I482A Overly-Bearden silt loams	NW1 Classification: None		Wetland ID: N/A
Landform: Flats	Local Relief: Concave		Sample Point: U14
Slope (%): 0-2	Latitude: --	Longitude: --	Datum: NAD 83
Are climatic/hydrologic conditions on the site typical for this time of year? (If no, explain in remarks) <input checked="" type="checkbox"/> Yes <input type="checkbox"/> No			Community ID: Agricultural commodity
Are Vegetation <input checked="" type="checkbox"/> , Soil <input checked="" type="checkbox"/> , or Hydrology <input checked="" type="checkbox"/> significantly disturbed?		Are normal circumstances present? <input type="checkbox"/> Yes <input checked="" type="checkbox"/> No	
Are Vegetation <input type="checkbox"/> , Soil <input type="checkbox"/> , or Hydrology <input type="checkbox"/> naturally problematic? <input type="checkbox"/> Yes <input checked="" type="checkbox"/> No		Township: 140N	
		Range: \$1W Dir: --	

SUMMARY OF FINDINGS

Hydrophytic Vegetation Present? <input type="checkbox"/> Yes <input checked="" type="checkbox"/> No	Hydric Soils Present? <input type="checkbox"/> Yes <input checked="" type="checkbox"/> No
Wetland Hydrology Present? <input type="checkbox"/> Yes <input checked="" type="checkbox"/> No	Is This Sampling Point Within A Wetland? <input checked="" type="checkbox"/> Yes <input type="checkbox"/> No

Remarks: **Sample point is located in a successfully cropped area of an agricultural field subjected to frequent tilling.**

HYDROLOGY

Wetland Hydrology Indicators (Check here if indicators are not present):

<p><u>Primary:</u></p> <ul style="list-style-type: none"> <input type="checkbox"/> A1 - Surface Water <input type="checkbox"/> A2 - High Water Table <input type="checkbox"/> A3 - Saturation <input type="checkbox"/> B1 - Water Marks <input type="checkbox"/> B2 - Sediment Deposits <input type="checkbox"/> B3 - Drift Deposits <input type="checkbox"/> B4 - Algal Mat or Crust <input type="checkbox"/> B5 - Iron Deposits <input type="checkbox"/> B7 - Inundation Visible on Aerial Imagery <input type="checkbox"/> B9 - Water Stained Leaves 	<ul style="list-style-type: none"> <input type="checkbox"/> B11 - Salt Crust <input type="checkbox"/> B13 - Aquatic Invertebrates <input type="checkbox"/> C1 - Hydrogen Sulfide Odor <input type="checkbox"/> C2 - Dry-Season Water Table <input type="checkbox"/> C3 - Oxidized Rhizospheres on Living Roots (where not tilled) <input type="checkbox"/> C4 - Presence of Reduced Iron <input type="checkbox"/> C7 - Thin Muck Surface <input type="checkbox"/> Other (Explain in Remarks) 	<p><u>Secondary:</u></p> <ul style="list-style-type: none"> <input type="checkbox"/> B6 - Surface Soil Cracks <input type="checkbox"/> B8 - Sparsely Vegetated Concave Surface <input type="checkbox"/> B10 - Drainage Patterns <input type="checkbox"/> C3 - Oxidized Rhizospheres on Living Roots (where tilled) <input type="checkbox"/> C8 - Crayfish Burrows <input type="checkbox"/> C9 - Saturation Visible on Aerial Imagery <input checked="" type="checkbox"/> D2 - Geomorphic Position <input type="checkbox"/> D5 - FAC-Neutral Test <input type="checkbox"/> D7 - Frost-Heave Hummocks (LRR F)
---	--	--

<p>Field Observations:</p> <p>Surface Water Present? <input type="checkbox"/> Yes <input checked="" type="checkbox"/> No Depth: 0 (in.)</p> <p>Water Table Present? <input type="checkbox"/> Yes <input checked="" type="checkbox"/> No Depth: >24 (in.)</p> <p>Saturation Present? <input type="checkbox"/> Yes <input checked="" type="checkbox"/> No Depth: >24 (in.)</p>	<p>Wetland Hydrology Present? <input type="checkbox"/> Yes <input checked="" type="checkbox"/> No</p>
---	--

Describe Recorded Data (stream gauge, monitoring well, aerial photos, previous inspections), if available: **N/A**

Remarks: **Sample point is located near a toe slope of a section road with 1% slope differentiation from surrounding topography.**

SOILS

Map Unit Name: **I482A Overly-Bearden silt loams** Series Drainage Class: **Moderately well drained**

Taxonomy (Subgroup):

Profile Description (Describe to the depth needed to document the indicator or confirm the absence of indicators.) (Type: C=Concentration, D=Depletion, RM=Reduced Matrix, CS=Covered/Coated Sand Grains, Location: PL=Pore Lining, M=Matrix)

Top Depth	Bottom Depth	Horizon	Matrix			Redox Features				Texture (e.g. clay, sand, loam)	
			Color (Moist)	%		Color (Moist)	%	Type	Location		
0	8	Ap	10YR	2/1	100	--	None	--	--	--	silt loam
8	24	A	10YR	2/1	100	--	None	--	--	--	silt loam
--	--	--	--	--	--	--	--	--	--	--	--
--	--	--	--	--	--	--	--	--	--	--	--
--	--	--	--	--	--	--	--	--	--	--	--
--	--	--	--	--	--	--	--	--	--	--	--
--	--	--	--	--	--	--	--	--	--	--	--

NRCS Hydric Soil Field Indicators (check here if indicators are not present):

<ul style="list-style-type: none"> <input type="checkbox"/> A1 - Histosol <input type="checkbox"/> A2 - Histic Epipedon <input type="checkbox"/> A3 - Black Histic <input type="checkbox"/> A4 - Hydrogen Sulfide <input type="checkbox"/> A5 - Stratified Layers (LRR F) <input type="checkbox"/> A9 - 1 cm Muck (LRR F, G, H) <input type="checkbox"/> A11 - Depleted Below Dark Surface <input type="checkbox"/> A12 - Thick Dark Surface <input type="checkbox"/> S1 - Sandy Muck Mineral <input type="checkbox"/> S2 - 2.5 cm Mucky Peat or Peat (LRR G, H) 	<ul style="list-style-type: none"> <input type="checkbox"/> S3 - 5cm Mucky Peat or Peat (LRR F) <input type="checkbox"/> S4 - Sandy Gleyed Matrix <input type="checkbox"/> S5 - Sandy Redox <input type="checkbox"/> S6 - Stripped Matrix <input type="checkbox"/> F1 - Loamy Mucky Mineral <input type="checkbox"/> F2 Loamy Gleyed Matrix <input type="checkbox"/> F3 - Depleted Matrix <input type="checkbox"/> F6 - Redox Dark Surface <input type="checkbox"/> F7 - Depleted Dark Surface <input type="checkbox"/> F8 - Redox Depressions 	<ul style="list-style-type: none"> <input type="checkbox"/> F16 - High Plains Depressions (MLRA 72, 73 of LRR H) <input type="checkbox"/> A9 - 1cm Muck (LRR I, J) <input type="checkbox"/> A16 - Coast Prairie Redox (LRR F, G, H) <input type="checkbox"/> S7 - Dark Surface (LRR G) <input type="checkbox"/> F16 - High Plains Depressions (LRR H outside MLRA 72, 73) <input type="checkbox"/> F18 - Reduced Vertic <input type="checkbox"/> TF2 - Red Parent Material <input type="checkbox"/> TF12 - Very Shallow Dark Surface <input type="checkbox"/> Other (Explain in Remarks)
--	--	---

¹ Indicators of hydrophytic vegetation and wetland hydrology must be present, unless disturbed or problematic.

Restrictive Layer (If Observed)	Type: N/A	Depth: N/A	Hydric Soil Present? <input type="checkbox"/> Yes <input checked="" type="checkbox"/> No
---------------------------------	------------------	-------------------	---

Remarks: **The only applicable hydric soil indicator beyond 12" is "Thick Dark Surface (A12), for which the sample point does not meet the requirements.**

Project/Site: **Harmony Solar Array** Wetland ID: **N/A** Sample Point **U14**
VEGETATION (Species identified in all uppercase are non-native species.)

Tree Stratum (Plot size: 30 ft radius)					Dominance Test Worksheet Number of Dominant Species that are OBL, FACW, or FAC: <u>0</u> (A) Total Number of Dominant Species Across All Strata: <u>1</u> (B) Percent of Dominant Species That Are OBL, FACW, or FAC: <u>0.0%</u> (A/B)																																										
1.	Species Name	% Cover	Dominant	Ind. Status																																											
2.	--	--	--	--																																											
3.	--	--	--	--																																											
4.	--	--	--	--																																											
5.	--	--	--	--																																											
6.	--	--	--	--																																											
7.	--	--	--	--																																											
8.	--	--	--	--																																											
9.	--	--	--	--																																											
Total Cover =		0																																													
Sapling/Shrub Stratum (Plot size: 15 ft radius)					Prevalence Index Worksheet Total % Cover of: <table style="margin-left: 20px; border-collapse: collapse;"> <tr> <td style="padding-right: 10px;">OBL spp.</td> <td style="border-bottom: 1px solid black; width: 50px; text-align: center;">0</td> <td style="padding: 0 10px;">x</td> <td style="border-bottom: 1px solid black; width: 50px; text-align: center;">1</td> <td style="padding: 0 10px;">=</td> <td style="border-bottom: 1px solid black; width: 50px; text-align: center;">0</td> </tr> <tr> <td>FACW spp.</td> <td style="border-bottom: 1px solid black; text-align: center;">0</td> <td>x</td> <td style="border-bottom: 1px solid black; text-align: center;">2</td> <td>=</td> <td style="border-bottom: 1px solid black; text-align: center;">0</td> </tr> <tr> <td>FAC spp.</td> <td style="border-bottom: 1px solid black; text-align: center;">0</td> <td>x</td> <td style="border-bottom: 1px solid black; text-align: center;">3</td> <td>=</td> <td style="border-bottom: 1px solid black; text-align: center;">0</td> </tr> <tr> <td>FACU spp.</td> <td style="border-bottom: 1px solid black; text-align: center;">0</td> <td>x</td> <td style="border-bottom: 1px solid black; text-align: center;">4</td> <td>=</td> <td style="border-bottom: 1px solid black; text-align: center;">0</td> </tr> <tr> <td>UPL spp.</td> <td style="border-bottom: 1px solid black; text-align: center;">20</td> <td>x</td> <td style="border-bottom: 1px solid black; text-align: center;">5</td> <td>=</td> <td style="border-bottom: 1px solid black; text-align: center;">100</td> </tr> <tr> <td colspan="2" style="padding-top: 10px;">Total</td> <td style="padding-top: 10px;">20</td> <td style="padding-top: 10px;">(A)</td> <td></td> <td style="padding-top: 10px;">100</td> </tr> <tr> <td colspan="2"></td> <td colspan="2"></td> <td style="padding-top: 10px;">Prevalence Index = B/A =</td> <td style="padding-top: 10px;">5.000</td> </tr> </table>	OBL spp.	0	x	1	=	0	FACW spp.	0	x	2	=	0	FAC spp.	0	x	3	=	0	FACU spp.	0	x	4	=	0	UPL spp.	20	x	5	=	100	Total		20	(A)		100					Prevalence Index = B/A =	5.000
OBL spp.	0	x	1	=		0																																									
FACW spp.	0	x	2	=		0																																									
FAC spp.	0	x	3	=		0																																									
FACU spp.	0	x	4	=		0																																									
UPL spp.	20	x	5	=		100																																									
Total		20	(A)			100																																									
				Prevalence Index = B/A =		5.000																																									
1.	--	--	--	--																																											
2.	--	--	--	--																																											
3.	--	--	--	--																																											
4.	--	--	--	--																																											
5.	--	--	--	--																																											
6.	--	--	--	--																																											
7.	--	--	--	--																																											
8.	--	--	--	--																																											
9.	--	--	--	--																																											
10.	--	--	--	--																																											
Total Cover =		0																																													
Herb Stratum (Plot size: 5 ft radius)					Hydrophytic Vegetation Indicators: <input type="checkbox"/> Yes <input checked="" type="checkbox"/> No Rapid Test for Hydrophytic Vegetation <input type="checkbox"/> Yes <input checked="" type="checkbox"/> No Dominance Test is > 50% <input type="checkbox"/> Yes <input checked="" type="checkbox"/> No Prevalence Index is ≤ 3.0 * <input type="checkbox"/> Yes <input type="checkbox"/> No Morphological Adaptations (Explain) * <input type="checkbox"/> Yes <input type="checkbox"/> No Problem Hydrophytic Vegetation (Explain) * * Indicators of hydric soil and wetland hydrology must be present, unless disturbed or problematic.																																										
1.	ZEA MAYS	20	Y	UPL																																											
2.	--	--	--	--																																											
3.	--	--	--	--																																											
4.	--	--	--	--																																											
5.	--	--	--	--																																											
6.	--	--	--	--																																											
7.	--	--	--	--																																											
8.	--	--	--	--																																											
9.	--	--	--	--																																											
10.	--	--	--	--																																											
11.	--	--	--	--																																											
12.	--	--	--	--																																											
13.	--	--	--	--																																											
14.	--	--	--	--																																											
15.	--	--	--	--																																											
Total Cover =		20																																													
Woody Vine Stratum (Plot size: 30 ft radius)					Definitions of Vegetation Strata: <p style="margin-left: 40px;">Tree - Woody plants 3 in. (7.6cm) or more in diameter at breast height (DBH), regardless of height.</p> <p style="margin-left: 40px;">Sapling/Shrub - Woody plants less than 3 in. DBH and greater than 3.28 ft. tall.</p> <p style="margin-left: 40px;">Herb - All herbaceous (non-woody) plants, regardless of size, and woody plants less than 3.28 ft. tall.</p> <p style="margin-left: 40px;">Woody Vines - All woody vines greater than 3.28 ft. in height.</p>																																										
1.	--	--	--	--																																											
2.	--	--	--	--																																											
3.	--	--	--	--																																											
4.	--	--	--	--																																											
5.	--	--	--	--																																											
Total Cover =		0																																													
Remarks: Agricultural corn commodity successfully harvested.																																															

Additional Remarks:

Sample point located in an area identified as a wet signature from aerial imagery. The sample point is in a successfully cropped field, lacking hydrophytic, hydrologic, and hydric soil indicators. The sample point is not a wetland feature.

Project/Site: Harmony Solar Array		Stantec Project #: 193704812	Date: 10/20/16
Applicant: Harmony Solar ND LLC			County: Cass
Investigator #1: Joseph Sander		Investigator #2:	State: North Dakota
Soil Unit: I119A Bearden silty clay loam		NWI Classification: PEM1A	Wetland ID: N/A
Landform: Flats	Local Relief: None		Sample Point: U15
Slope (%): 0-2	Latitude: --	Longitude: --	Datum: NAD 83
Are climatic/hydrologic conditions on the site typical for this time of year? (If no, explain in remarks) <input checked="" type="checkbox"/> Yes <input type="checkbox"/> No			Community ID: Agricultural commodity
Are Vegetation <input checked="" type="checkbox"/> , Soil <input checked="" type="checkbox"/> , or Hydrology <input checked="" type="checkbox"/> significantly disturbed?		Are normal circumstances present? <input type="checkbox"/> Yes <input checked="" type="checkbox"/> No	
Are Vegetation <input type="checkbox"/> , Soil <input type="checkbox"/> , or Hydrology <input type="checkbox"/> naturally problematic? <input type="checkbox"/> Yes <input checked="" type="checkbox"/> No		Township: 140N	
		Range: 51W Dir: --	

SUMMARY OF FINDINGS

Hydrophytic Vegetation Present? <input type="checkbox"/> Yes <input checked="" type="checkbox"/> No	Hydric Soils Present? <input type="checkbox"/> Yes <input checked="" type="checkbox"/> No
Wetland Hydrology Present? <input type="checkbox"/> Yes <input checked="" type="checkbox"/> No	Is This Sampling Point Within A Wetland? <input checked="" type="checkbox"/> Yes <input type="checkbox"/> No

Remarks: **Sample point is located in a successfully cropped area of an agricultural field subjected to frequent tilling.**

HYDROLOGY

Wetland Hydrology Indicators (Check here if indicators are not present):

<p><u>Primary:</u></p> <ul style="list-style-type: none"> <input type="checkbox"/> A1 - Surface Water <input type="checkbox"/> A2 - High Water Table <input type="checkbox"/> A3 - Saturation <input type="checkbox"/> B1 - Water Marks <input type="checkbox"/> B2 - Sediment Deposits <input type="checkbox"/> B3 - Drift Deposits <input type="checkbox"/> B4 - Algal Mat or Crust <input type="checkbox"/> B5 - Iron Deposits <input type="checkbox"/> B7 - Inundation Visible on Aerial Imagery <input type="checkbox"/> B9 - Water Stained Leaves 	<ul style="list-style-type: none"> <input type="checkbox"/> B11 - Salt Crust <input type="checkbox"/> B13 - Aquatic Invertebrates <input type="checkbox"/> C1 - Hydrogen Sulfide Odor <input type="checkbox"/> C2 - Dry-Season Water Table <input type="checkbox"/> C3 - Oxidized Rhizospheres on Living Roots (where not tilled) <input type="checkbox"/> C4 - Presence of Reduced Iron <input type="checkbox"/> C7 - Thin Muck Surface <input type="checkbox"/> Other (Explain in Remarks) 	<p><u>Secondary:</u></p> <ul style="list-style-type: none"> <input type="checkbox"/> B6 - Surface Soil Cracks <input type="checkbox"/> B8 - Sparsely Vegetated Concave Surface <input type="checkbox"/> B10 - Drainage Patterns <input type="checkbox"/> C3 - Oxidized Rhizospheres on Living Roots (where tilled) <input type="checkbox"/> C8 - Crayfish Burrows <input type="checkbox"/> C9 - Saturation Visible on Aerial Imagery <input type="checkbox"/> D2 - Geomorphic Position <input type="checkbox"/> D5 - FAC-Neutral Test <input type="checkbox"/> D7 - Frost-Heave Hummocks (LRR F)
---	--	---

Field Observations:

Surface Water Present? <input type="checkbox"/> Yes <input checked="" type="checkbox"/> No	Depth: 0 (in.)	Wetland Hydrology Present? <input type="checkbox"/> Yes <input checked="" type="checkbox"/> No
Water Table Present? <input type="checkbox"/> Yes <input checked="" type="checkbox"/> No	Depth: >24 (in.)	
Saturation Present? <input type="checkbox"/> Yes <input checked="" type="checkbox"/> No	Depth: >24 (in.)	

Describe Recorded Data (stream gauge, monitoring well, aerial photos, previous inspections), if available: **N/A**

Remarks: **Sample point is located in an area without topological relief.**

SOILS

Map Unit Name: **I119A Bearden silty clay loam** Series Drainage Class: **Somewhat poorly drained**

Taxonomy (Subgroup):

Profile Description (Describe to the depth needed to document the indicator or confirm the absence of indicators.) (Type: C=Concentration, D=Depletion, RM=Reduced Matrix, CS=Covered/Coated Sand Grains, Location: PL=Pore Lining, M=Matrix)

Top Depth	Bottom Depth	Horizon	Matrix			Redox Features				Texture (e.g. clay, sand, loam)	
			Color (Moist)	%		Color (Moist)	%	Type	Location		
0	8	Ap	10YR	2/1	100	--	None	--	--	--	silty clay loam
8	17	A	10YR	2/1	100	--	None	--	--	--	silty clay loam
17	21	E	10YR	5/2	100	--	None	--	--	--	silty clay loam
21	24	B	10YR	2/1	100	--	None	--	--	--	silty clay loam
--	--	--	--	--	--	--	--	--	--	--	--
--	--	--	--	--	--	--	--	--	--	--	--
--	--	--	--	--	--	--	--	--	--	--	--
--	--	--	--	--	--	--	--	--	--	--	--

NRCS Hydric Soil Field Indicators (check here if indicators are not present):

<ul style="list-style-type: none"> <input type="checkbox"/> A1 - Histosol <input type="checkbox"/> A2 - Histic Epipedon <input type="checkbox"/> A3 - Black Histic <input type="checkbox"/> A4 - Hydrogen Sulfide <input type="checkbox"/> A5 - Stratified Layers (LRR F) <input type="checkbox"/> A9 - 1 cm Muck (LRR F, G, H) <input type="checkbox"/> A11 - Depleted Below Dark Surface <input type="checkbox"/> A12 - Thick Dark Surface <input type="checkbox"/> S1 - Sandy Muck Mineral <input type="checkbox"/> S2 - 2.5 cm Mucky Peat or Peat (LRR G, H) 	<ul style="list-style-type: none"> <input type="checkbox"/> S3 - 5cm Mucky Peat or Peat (LRR F) <input type="checkbox"/> S4 - Sandy Gleyed Matrix <input type="checkbox"/> S5 - Sandy Redox <input type="checkbox"/> S6 - Stripped Matrix <input type="checkbox"/> F1 - Loamy Mucky Mineral <input type="checkbox"/> F2 Loamy Gleyed Matrix <input type="checkbox"/> F3 - Depleted Matrix <input type="checkbox"/> F6 - Redox Dark Surface <input type="checkbox"/> F7 - Depleted Dark Surface <input type="checkbox"/> F8 - Redox Depressions 	<ul style="list-style-type: none"> <input type="checkbox"/> F16 - High Plains Depressions (MLRA 72, 73 of LRR H) <input type="checkbox"/> A9 - 1cm Muck (LRR I, J) <input type="checkbox"/> A16 - Coast Prairie Redox (LRR F, G, H) <input type="checkbox"/> S7 - Dark Surface (LRR G) <input type="checkbox"/> F16 - High Plains Depressions (LRR H outside MLRA 72, 73) <input type="checkbox"/> F18 - Reduced Vertic <input type="checkbox"/> TF2 - Red Parent Material <input type="checkbox"/> TF12 - Very Shallow Dark Surface <input type="checkbox"/> Other (Explain in Remarks)
--	--	---

¹ Indicators of hydrophytic vegetation and wetland hydrology must be present, unless disturbed or problematic.

Restrictive Layer (If Observed) Type: N/A	Depth: N/A	Hydric Soil Present? <input type="checkbox"/> Yes <input checked="" type="checkbox"/> No
--	-------------------	---

Remarks: **The only applicable hydric soil indicator beyond 12" is "Thick Dark Surface (A12), for which the sample point does not meet the requirements. Horizon E is not at least 6" thick.**

Project/Site: **Harmony Solar Array** Wetland ID: **N/A** Sample Point **U15**
VEGETATION (Species identified in all uppercase are non-native species.)

Tree Stratum (Plot size: 30 ft radius)				
	Species Name	% Cover	Dominant	Ind. Status
1.	--	--	--	--
2.	--	--	--	--
3.	--	--	--	--
4.	--	--	--	--
5.	--	--	--	--
6.	--	--	--	--
7.	--	--	--	--
8.	--	--	--	--
9.	--	--	--	--
10.	--	--	--	--
Total Cover =		0		

Dominance Test Worksheet	
Number of Dominant Species that are OBL, FACW, or FAC:	<u>0</u> (A)
Total Number of Dominant Species Across All Strata:	<u>1</u> (B)
Percent of Dominant Species That Are OBL, FACW, or FAC:	<u>0.0%</u> (A/B)

Sapling/Shrub Stratum (Plot size: 15 ft radius)				
	Species Name	% Cover	Dominant	Ind. Status
1.	--	--	--	--
2.	--	--	--	--
3.	--	--	--	--
4.	--	--	--	--
5.	--	--	--	--
6.	--	--	--	--
7.	--	--	--	--
8.	--	--	--	--
9.	--	--	--	--
10.	--	--	--	--
Total Cover =		0		

Prevalence Index Worksheet	
Total % Cover of:	Multiply by:
OBL spp. <u>0</u>	x 1 = <u>0</u>
FACW spp. <u>0</u>	x 2 = <u>0</u>
FAC spp. <u>0</u>	x 3 = <u>0</u>
FACU spp. <u>0</u>	x 4 = <u>0</u>
UPL spp. <u>70</u>	x 5 = <u>350</u>
Total <u>70</u> (A)	<u>350</u> (B)
Prevalence Index = B/A = <u>5.000</u>	

Herb Stratum (Plot size: 5 ft radius)				
	Species Name	% Cover	Dominant	Ind. Status
1.	GLYCINE MAX	70	Y	UPL
2.	--	--	--	--
3.	--	--	--	--
4.	--	--	--	--
5.	--	--	--	--
6.	--	--	--	--
7.	--	--	--	--
8.	--	--	--	--
9.	--	--	--	--
10.	--	--	--	--
11.	--	--	--	--
12.	--	--	--	--
13.	--	--	--	--
14.	--	--	--	--
15.	--	--	--	--
Total Cover =		70		

Hydrophytic Vegetation Indicators:		
<input type="checkbox"/> Yes	<input checked="" type="checkbox"/> No	Rapid Test for Hydrophytic Vegetation
<input type="checkbox"/> Yes	<input checked="" type="checkbox"/> No	Dominance Test is > 50%
<input type="checkbox"/> Yes	<input checked="" type="checkbox"/> No	Prevalence Index is ≤ 3.0 *
<input type="checkbox"/> Yes	<input type="checkbox"/> No	Morphological Adaptations (Explain) *
<input type="checkbox"/> Yes	<input type="checkbox"/> No	Problem Hydrophytic Vegetation (Explain) *

* Indicators of hydric soil and wetland hydrology must be present, unless disturbed or problematic.

Woody Vine Stratum (Plot size: 30 ft radius)				
	Species Name	% Cover	Dominant	Ind. Status
1.	--	--	--	--
2.	--	--	--	--
3.	--	--	--	--
4.	--	--	--	--
5.	--	--	--	--
Total Cover =		0		

Definitions of Vegetation Strata:	
Tree	Woody plants 3 in. (7.6cm) or more in diameter at breast height (DBH), regardless of height.
Sapling/Shrub	Woody plants less than 3 in. DBH and greater than 3.28 ft. tall.
Herb	All herbaceous (non-woody) plants, regardless of size, and woody plants less than 3.28 ft. tall.
Woody Vines	All woody vines greater than 3.28 ft. in height.

 Remarks: **Agricultural soybean commodity successfully harvested.**

Hydrophytic Vegetation Present	<input type="checkbox"/> Yes	<input checked="" type="checkbox"/> No
---------------------------------------	------------------------------	--

Additional Remarks:

Sample point located in an area identified as a NWI feature. The sample point is in a successfully cropped field, lacking hydrophytic, hydrologic, and hydric soil indicators. The sample point is not a wetland feature.

Project/Site: Harmony Solar Array		Stantec Project #: 193704812	Date: 10/20/16
Applicant: Harmony Solar ND LLC			County: Cass
Investigator #1: Joseph Sander		Investigator #2:	State: North Dakota
Soil Unit: I373A Kindred-Bearden silty clay loams	NWI Classification: None	Wetland ID: N/A	Sample Point: U16
Landform: Swailes, Flats	Local Relief: None	Community ID: Agricultural commodity	Section: 10
Slope (%): 0-2	Latitude: --	Longitude: --	Datum: NAD 83
Are climatic/hydrologic conditions on the site typical for this time of year? (If no, explain in remarks) <input checked="" type="checkbox"/> Yes <input type="checkbox"/> No		Are normal circumstances present? <input type="checkbox"/> Yes <input checked="" type="checkbox"/> No	
Are Vegetation <input checked="" type="checkbox"/> , Soil <input checked="" type="checkbox"/> , or Hydrology <input checked="" type="checkbox"/> significantly disturbed?		Are Vegetation <input type="checkbox"/> , Soil <input type="checkbox"/> , or Hydrology <input type="checkbox"/> naturally problematic? <input type="checkbox"/> Yes <input checked="" type="checkbox"/> No	
Township: 140N		Range: 51W Dir: --	

SUMMARY OF FINDINGS

Hydrophytic Vegetation Present? <input type="checkbox"/> Yes <input checked="" type="checkbox"/> No	Hydric Soils Present? <input type="checkbox"/> Yes <input checked="" type="checkbox"/> No
Wetland Hydrology Present? <input type="checkbox"/> Yes <input checked="" type="checkbox"/> No	Is This Sampling Point Within A Wetland? <input checked="" type="checkbox"/> Yes <input type="checkbox"/> No

Remarks: **Sample point is located in a successfully cropped area of an agricultural field subjected to frequent tilling.**

HYDROLOGY

Wetland Hydrology Indicators (Check here if indicators are not present):

<p><u>Primary:</u></p> <ul style="list-style-type: none"> <input type="checkbox"/> A1 - Surface Water <input type="checkbox"/> A2 - High Water Table <input type="checkbox"/> A3 - Saturation <input type="checkbox"/> B1 - Water Marks <input type="checkbox"/> B2 - Sediment Deposits <input type="checkbox"/> B3 - Drift Deposits <input type="checkbox"/> B4 - Algal Mat or Crust <input type="checkbox"/> B5 - Iron Deposits <input type="checkbox"/> B7 - Inundation Visible on Aerial Imagery <input type="checkbox"/> B9 - Water Stained Leaves 	<ul style="list-style-type: none"> <input type="checkbox"/> B11 - Salt Crust <input type="checkbox"/> B13 - Aquatic Invertebrates <input type="checkbox"/> C1 - Hydrogen Sulfide Odor <input type="checkbox"/> C2 - Dry-Season Water Table <input type="checkbox"/> C3 - Oxidized Rhizospheres on Living Roots (where not tilled) <input type="checkbox"/> C4 - Presence of Reduced Iron <input type="checkbox"/> C7 - Thin Muck Surface <input type="checkbox"/> Other (Explain in Remarks) 	<p><u>Secondary:</u></p> <ul style="list-style-type: none"> <input type="checkbox"/> B6 - Surface Soil Cracks <input type="checkbox"/> B8 - Sparsely Vegetated Concave Surface <input type="checkbox"/> B10 - Drainage Patterns <input type="checkbox"/> C3 - Oxidized Rhizospheres on Living Roots (where tilled) <input type="checkbox"/> C8 - Crayfish Burrows <input type="checkbox"/> C9 - Saturation Visible on Aerial Imagery <input type="checkbox"/> D2 - Geomorphic Position <input type="checkbox"/> D5 - FAC-Neutral Test <input type="checkbox"/> D7 - Frost-Heave Hummocks (LRR F)
---	--	---

Field Observations: Surface Water Present? <input type="checkbox"/> Yes <input checked="" type="checkbox"/> No Depth: 0 (in.) Water Table Present? <input type="checkbox"/> Yes <input checked="" type="checkbox"/> No Depth: >24 (in.) Saturation Present? <input type="checkbox"/> Yes <input checked="" type="checkbox"/> No Depth: >24 (in.)	Wetland Hydrology Present? <input type="checkbox"/> Yes <input checked="" type="checkbox"/> No
--	---

Describe Recorded Data (stream gauge, monitoring well, aerial photos, previous inspections), if available: **N/A**

Remarks: **Sample point is located near a stream bank with no relief in topography.**

SOILS

Map Unit Name: **I373A Kindred-Bearden silty clay loams** Series Drainage Class: **Somewhat poorly drained**

Taxonomy (Subgroup):

Profile Description (Describe to the depth needed to document the indicator or confirm the absence of indicators.) (Type: C=Concentration, D=Depletion, RM=Reduced Matrix, CS=Covered/Coated Sand Grains, Location: PL=Pore Lining, M=Matrix)

Top Depth	Bottom Depth	Horizon	Matrix			Redox Features				Texture (e.g. clay, sand, loam)	
			Color (Moist)	%		Color (Moist)	%	Type	Location		
0	8	Ap	10YR	2/1	100	--	None	--	--	--	silty clay loam
8	24	A	10YR	2/1	100	--	None	--	--	--	silty clay loam
--	--	--	--	--	--	--	--	--	--	--	--
--	--	--	--	--	--	--	--	--	--	--	--
--	--	--	--	--	--	--	--	--	--	--	--
--	--	--	--	--	--	--	--	--	--	--	--
--	--	--	--	--	--	--	--	--	--	--	--

NRCS Hydric Soil Field Indicators (check here if indicators are not present):

<ul style="list-style-type: none"> <input type="checkbox"/> A1 - Histosol <input type="checkbox"/> A2 - Histic Epipedon <input type="checkbox"/> A3 - Black Histic <input type="checkbox"/> A4 - Hydrogen Sulfide <input type="checkbox"/> A5 - Stratified Layers (LRR F) <input type="checkbox"/> A9 - 1 cm Muck (LRR F, G, H) <input type="checkbox"/> A11 - Depleted Below Dark Surface <input type="checkbox"/> A12 - Thick Dark Surface <input type="checkbox"/> S1 - Sandy Muck Mineral <input type="checkbox"/> S2 - 2.5 cm Mucky Peat or Peat (LRR G, H) 	<ul style="list-style-type: none"> <input type="checkbox"/> S3 - 5cm Mucky Peat or Peat (LRR F) <input type="checkbox"/> S4 - Sandy Gleyed Matrix <input type="checkbox"/> S5 - Sandy Redox <input type="checkbox"/> S6 - Stripped Matrix <input type="checkbox"/> F1 - Loamy Mucky Mineral <input type="checkbox"/> F2 Loamy Gleyed Matrix <input type="checkbox"/> F3 - Depleted Matrix <input type="checkbox"/> F6 - Redox Dark Surface <input type="checkbox"/> F7 - Depleted Dark Surface <input type="checkbox"/> F8 - Redox Depressions 	<ul style="list-style-type: none"> <input type="checkbox"/> F16 - High Plains Depressions (MLRA 72, 73 of LRR H) <input type="checkbox"/> A9 - 1cm Muck (LRR I, J) <input type="checkbox"/> A16 - Coast Prairie Redox (LRR F, G, H) <input type="checkbox"/> S7 - Dark Surface (LRR G) <input type="checkbox"/> F16 - High Plains Depressions (LRR H outside MLRA 72, 73) <input type="checkbox"/> F18 - Reduced Vertic <input type="checkbox"/> TF2 - Red Parent Material <input type="checkbox"/> TF12 - Very Shallow Dark Surface <input type="checkbox"/> Other (Explain in Remarks)
--	--	---

¹ Indicators of hydrophytic vegetation and wetland hydrology must be present, unless disturbed or problematic.

Restrictive Layer (If Observed) Type: N/A	Depth: N/A	Hydric Soil Present? <input type="checkbox"/> Yes <input checked="" type="checkbox"/> No
--	-------------------	---

Remarks: **The only applicable hydric soil indicator beyond 12" is "Thick Dark Surface (A12), for which the sample point does not meet the requirements.**

Project/Site: **Harmony Solar Array** Wetland ID: **N/A** Sample Point **U16**
VEGETATION (Species identified in all uppercase are non-native species.)

Tree Stratum (Plot size: 30 ft radius)				
	Species Name	% Cover	Dominant	Ind. Status
1.	--	--	--	--
2.	--	--	--	--
3.	--	--	--	--
4.	--	--	--	--
5.	--	--	--	--
6.	--	--	--	--
7.	--	--	--	--
8.	--	--	--	--
9.	--	--	--	--
10.	--	--	--	--
Total Cover =		0		

Dominance Test Worksheet	
Number of Dominant Species that are OBL, FACW, or FAC:	<u>0</u> (A)
Total Number of Dominant Species Across All Strata:	<u>1</u> (B)
Percent of Dominant Species That Are OBL, FACW, or FAC:	<u>0.0%</u> (A/B)

Sapling/Shrub Stratum (Plot size: 15 ft radius)				
	Species Name	% Cover	Dominant	Ind. Status
1.	--	--	--	--
2.	--	--	--	--
3.	--	--	--	--
4.	--	--	--	--
5.	--	--	--	--
6.	--	--	--	--
7.	--	--	--	--
8.	--	--	--	--
9.	--	--	--	--
10.	--	--	--	--
Total Cover =		0		

Prevalence Index Worksheet	
Total % Cover of:	Multiply by:
OBL spp. <u>0</u>	x 1 = <u>0</u>
FACW spp. <u>0</u>	x 2 = <u>0</u>
FAC spp. <u>0</u>	x 3 = <u>0</u>
FACU spp. <u>0</u>	x 4 = <u>0</u>
UPL spp. <u>20</u>	x 5 = <u>100</u>
Total <u>20</u> (A)	<u>100</u> (B)
Prevalence Index = B/A = <u>5.000</u>	

Herb Stratum (Plot size: 5 ft radius)				
	Species Name	% Cover	Dominant	Ind. Status
1.	ZEA MAYS	20	Y	UPL
2.	--	--	--	--
3.	--	--	--	--
4.	--	--	--	--
5.	--	--	--	--
6.	--	--	--	--
7.	--	--	--	--
8.	--	--	--	--
9.	--	--	--	--
10.	--	--	--	--
11.	--	--	--	--
12.	--	--	--	--
13.	--	--	--	--
14.	--	--	--	--
15.	--	--	--	--
Total Cover =		20		

Hydrophytic Vegetation Indicators:		
<input type="checkbox"/> Yes	<input checked="" type="checkbox"/> No	Rapid Test for Hydrophytic Vegetation
<input type="checkbox"/> Yes	<input checked="" type="checkbox"/> No	Dominance Test is > 50%
<input type="checkbox"/> Yes	<input checked="" type="checkbox"/> No	Prevalence Index is ≤ 3.0 *
<input type="checkbox"/> Yes	<input type="checkbox"/> No	Morphological Adaptations (Explain) *
<input type="checkbox"/> Yes	<input type="checkbox"/> No	Problem Hydrophytic Vegetation (Explain) *

* Indicators of hydric soil and wetland hydrology must be present, unless disturbed or problematic.

Woody Vine Stratum (Plot size: 30 ft radius)				
	Species Name	% Cover	Dominant	Ind. Status
1.	--	--	--	--
2.	--	--	--	--
3.	--	--	--	--
4.	--	--	--	--
5.	--	--	--	--
Total Cover =		0		

Definitions of Vegetation Strata:	
Tree	- Woody plants 3 in. (7.6cm) or more in diameter at breast height (DBH), regardless of height.
Sapling/Shrub	- Woody plants less than 3 in. DBH and greater than 3.28 ft. tall.
Herb	- All herbaceous (non-woody) plants, regardless of size, and woody plants less than 3.28 ft. tall.
Woody Vines	- All woody vines greater than 3.28 ft. in height.

 Remarks: **Agricultural corn commodity successfully harvested.**

Hydrophytic Vegetation Present	<input type="checkbox"/> Yes	<input checked="" type="checkbox"/> No
---------------------------------------	------------------------------	--

Additional Remarks:

Sample point located in an area just outside of a stream bank incision. The sample point is in a successfully cropped field, lacking hydrophytic, hydrologic, and hydric soil indicators. The sample point is not a wetland feature.

Project/Site: Harmony Solar Array		Stantec Project #: 193704812	Date: 10/20/16
Applicant: Harmony Solar ND LLC			County: Cass
Investigator #1: Joseph Sander		Investigator #2:	State: North Dakota
Soil Unit: I229A Fargo silty clay	NWI Classification: PEM1ax	Local Relief: Concave	Wetland ID: N/A
Landform: Flats	Latitude: --	Longitude: --	Sample Point: U17
Slope (%): 0-1	Datum: NAD 83	Community ID: Agricultural commodity	
Are climatic/hydrologic conditions on the site typical for this time of year? (If no, explain in remarks) <input checked="" type="checkbox"/> Yes <input type="checkbox"/> No			Section: 11
Are Vegetation <input checked="" type="checkbox"/> , Soil <input checked="" type="checkbox"/> , or Hydrology <input checked="" type="checkbox"/> significantly disturbed?		Are normal circumstances present? <input type="checkbox"/> Yes <input checked="" type="checkbox"/> No	
Are Vegetation <input type="checkbox"/> , Soil <input type="checkbox"/> , or Hydrology <input type="checkbox"/> naturally problematic? <input type="checkbox"/> Yes <input checked="" type="checkbox"/> No		Township: 140N	
		Range: \$1W Dir: --	

SUMMARY OF FINDINGS

Hydrophytic Vegetation Present? <input type="checkbox"/> Yes <input checked="" type="checkbox"/> No	Hydric Soils Present? <input type="checkbox"/> Yes <input checked="" type="checkbox"/> No
Wetland Hydrology Present? <input type="checkbox"/> Yes <input checked="" type="checkbox"/> No	Is This Sampling Point Within A Wetland? <input checked="" type="checkbox"/> Yes <input type="checkbox"/> No

Remarks: **Sample point is located in a successfully cropped area of an agricultural field subjected to frequent tilling.**

HYDROLOGY

Wetland Hydrology Indicators (Check here if indicators are not present):

<p><u>Primary:</u></p> <ul style="list-style-type: none"> <input type="checkbox"/> A1 - Surface Water <input type="checkbox"/> A2 - High Water Table <input type="checkbox"/> A3 - Saturation <input type="checkbox"/> B1 - Water Marks <input type="checkbox"/> B2 - Sediment Deposits <input type="checkbox"/> B3 - Drift Deposits <input type="checkbox"/> B4 - Algal Mat or Crust <input type="checkbox"/> B5 - Iron Deposits <input type="checkbox"/> B7 - Inundation Visible on Aerial Imagery <input type="checkbox"/> B9 - Water Stained Leaves 	<ul style="list-style-type: none"> <input type="checkbox"/> B11 - Salt Crust <input type="checkbox"/> B13 - Aquatic Invertebrates <input type="checkbox"/> C1 - Hydrogen Sulfide Odor <input type="checkbox"/> C2 - Dry-Season Water Table <input type="checkbox"/> C3 - Oxidized Rhizospheres on Living Roots (where not tilled) <input type="checkbox"/> C4 - Presence of Reduced Iron <input type="checkbox"/> C7 - Thin Muck Surface <input type="checkbox"/> Other (Explain in Remarks) 	<p><u>Secondary:</u></p> <ul style="list-style-type: none"> <input checked="" type="checkbox"/> B6 - Surface Soil Cracks <input checked="" type="checkbox"/> B8 - Sparsely Vegetated Concave Surface <input type="checkbox"/> B10 - Drainage Patterns <input type="checkbox"/> C3 - Oxidized Rhizospheres on Living Roots (where tilled) <input type="checkbox"/> C8 - Crayfish Burrows <input type="checkbox"/> C9 - Saturation Visible on Aerial Imagery <input checked="" type="checkbox"/> D2 - Geomorphic Position <input type="checkbox"/> D5 - FAC-Neutral Test <input type="checkbox"/> D7 - Frost-Heave Hummocks (LRR F)
---	--	--

Field Observations:

Surface Water Present? <input type="checkbox"/> Yes <input checked="" type="checkbox"/> No	Depth: 0 (in.)	Wetland Hydrology Present? <input type="checkbox"/> Yes <input checked="" type="checkbox"/> No
Water Table Present? <input type="checkbox"/> Yes <input checked="" type="checkbox"/> No	Depth: >24 (in.)	
Saturation Present? <input type="checkbox"/> Yes <input checked="" type="checkbox"/> No	Depth: >24 (in.)	

Describe Recorded Data (stream gauge, monitoring well, aerial photos, previous inspections), if available: **N/A**

Remarks: **Sample point is located in a minor depression with 1% slope differentiation from topographical surroundings. The depression receives run-off from the surrounding area but does not appear to hold water long enough to create hydric soils.**

SOILS

Map Unit Name: **I229A Fargo silty clay** Series Drainage Class: **Poorly drained**

Taxonomy (Subgroup):

Profile Description (Describe to the depth needed to document the indicator or confirm the absence of indicators.) (Type: C=Concentration, D=Depletion, RM=Reduced Matrix, CS=Covered/Coated Sand Grains, Location: PL=Pore Lining, M=Matrix)

Top Depth	Bottom Depth	Horizon	Matrix			Redox Features				Texture (e.g. clay, sand, loam)	
			Color (Moist)	%		Color (Moist)	%	Type	Location		
0	8	Ap	10YR	2/1	100	--	None	--	--	--	silty clay
8	24	A	10YR	2/1	100	--	None	--	--	--	silty clay
--	--	--	--	--	--	--	--	--	--	--	--
--	--	--	--	--	--	--	--	--	--	--	--
--	--	--	--	--	--	--	--	--	--	--	--
--	--	--	--	--	--	--	--	--	--	--	--
--	--	--	--	--	--	--	--	--	--	--	--

NRCS Hydric Soil Field Indicators (check here if indicators are not present):

<ul style="list-style-type: none"> <input type="checkbox"/> A1 - Histosol <input type="checkbox"/> A2 - Histic Epipedon <input type="checkbox"/> A3 - Black Histic <input type="checkbox"/> A4 - Hydrogen Sulfide <input type="checkbox"/> A5 - Stratified Layers (LRR F) <input type="checkbox"/> A9 - 1 cm Muck (LRR F, G, H) <input type="checkbox"/> A11 - Depleted Below Dark Surface <input type="checkbox"/> A12 - Thick Dark Surface <input type="checkbox"/> S1 - Sandy Muck Mineral <input type="checkbox"/> S2 - 2.5 cm Mucky Peat or Peat (LRR G, H) 	<ul style="list-style-type: none"> <input type="checkbox"/> S3 - 5cm Mucky Peat or Peat (LRR F) <input type="checkbox"/> S4 - Sandy Gleyed Matrix <input type="checkbox"/> S5 - Sandy Redox <input type="checkbox"/> S6 - Stripped Matrix <input type="checkbox"/> F1 - Loamy Mucky Mineral <input type="checkbox"/> F2 Loamy Gleyed Matrix <input type="checkbox"/> F3 - Depleted Matrix <input type="checkbox"/> F6 - Redox Dark Surface <input type="checkbox"/> F7 - Depleted Dark Surface <input type="checkbox"/> F8 - Redox Depressions 	<ul style="list-style-type: none"> <input type="checkbox"/> F16 - High Plains Depressions (MLRA 72, 73 of LRR H) <input type="checkbox"/> A9 - 1cm Muck (LRR I, J) <input type="checkbox"/> A16 - Coast Prairie Redox (LRR F, G, H) <input type="checkbox"/> S7 - Dark Surface (LRR G) <input type="checkbox"/> F16 - High Plains Depressions (LRR H outside MLRA 72, 73) <input type="checkbox"/> F18 - Reduced Vertic <input type="checkbox"/> TF2 - Red Parent Material <input type="checkbox"/> TF12 - Very Shallow Dark Surface <input type="checkbox"/> Other (Explain in Remarks)
--	--	---

¹ Indicators of hydrophytic vegetation and wetland hydrology must be present, unless disturbed or problematic.

Restrictive Layer (If Observed) Type: **N/A** Depth: **N/A** **Hydric Soil Present?** Yes No

Remarks: **The only applicable hydric soil indicator beyond 12" is "Thick Dark Surface (A12)," for which this sample point does not meet the requirements.**

Project/Site: **Harmony Solar Array** Wetland ID: **N/A** Sample Point **U17**
VEGETATION (Species identified in all uppercase are non-native species.)

Tree Stratum (Plot size: 30 ft radius)					Dominance Test Worksheet Number of Dominant Species that are OBL, FACW, or FAC: <u>0</u> (A) Total Number of Dominant Species Across All Strata: <u>2</u> (B) Percent of Dominant Species That Are OBL, FACW, or FAC: <u>0.0%</u> (A/B)																																										
1.	Species Name	% Cover	Dominant	Ind. Status																																											
1.	--	--	--	--																																											
2.	--	--	--	--																																											
3.	--	--	--	--																																											
4.	--	--	--	--																																											
5.	--	--	--	--																																											
6.	--	--	--	--																																											
7.	--	--	--	--																																											
8.	--	--	--	--																																											
9.	--	--	--	--																																											
10.	--	--	--	--																																											
Total Cover =		0																																													
Sapling/Shrub Stratum (Plot size: 15 ft radius)					Prevalence Index Worksheet Total % Cover of: <table style="margin-left: 20px; border-collapse: collapse;"> <tr> <td style="padding-right: 10px;">OBL spp.</td> <td style="border-bottom: 1px solid black; width: 50px; text-align: center;">0</td> <td style="padding: 0 10px;">x</td> <td style="border-bottom: 1px solid black; width: 50px; text-align: center;">1</td> <td style="padding: 0 10px;">=</td> <td style="border-bottom: 1px solid black; width: 50px; text-align: center;">0</td> </tr> <tr> <td>FACW spp.</td> <td style="border-bottom: 1px solid black; text-align: center;">0</td> <td>x</td> <td style="border-bottom: 1px solid black; text-align: center;">2</td> <td>=</td> <td style="border-bottom: 1px solid black; text-align: center;">0</td> </tr> <tr> <td>FAC spp.</td> <td style="border-bottom: 1px solid black; text-align: center;">0</td> <td>x</td> <td style="border-bottom: 1px solid black; text-align: center;">3</td> <td>=</td> <td style="border-bottom: 1px solid black; text-align: center;">0</td> </tr> <tr> <td>FACU spp.</td> <td style="border-bottom: 1px solid black; text-align: center;">5</td> <td>x</td> <td style="border-bottom: 1px solid black; text-align: center;">4</td> <td>=</td> <td style="border-bottom: 1px solid black; text-align: center;">20</td> </tr> <tr> <td>UPL spp.</td> <td style="border-bottom: 1px solid black; text-align: center;">5</td> <td>x</td> <td style="border-bottom: 1px solid black; text-align: center;">5</td> <td>=</td> <td style="border-bottom: 1px solid black; text-align: center;">25</td> </tr> <tr> <td colspan="2" style="padding-top: 10px;">Total</td> <td style="padding-top: 10px;">10</td> <td style="padding-top: 10px;">(A)</td> <td></td> <td style="padding-top: 10px;">45</td> </tr> <tr> <td colspan="2"></td> <td colspan="2"></td> <td style="padding-top: 10px;">Prevalence Index = B/A =</td> <td style="padding-top: 10px;"><u>4.500</u></td> </tr> </table>	OBL spp.	0	x	1	=	0	FACW spp.	0	x	2	=	0	FAC spp.	0	x	3	=	0	FACU spp.	5	x	4	=	20	UPL spp.	5	x	5	=	25	Total		10	(A)		45					Prevalence Index = B/A =	<u>4.500</u>
OBL spp.	0	x	1	=		0																																									
FACW spp.	0	x	2	=		0																																									
FAC spp.	0	x	3	=		0																																									
FACU spp.	5	x	4	=		20																																									
UPL spp.	5	x	5	=		25																																									
Total		10	(A)			45																																									
				Prevalence Index = B/A =		<u>4.500</u>																																									
1.	--	--	--	--																																											
2.	--	--	--	--																																											
3.	--	--	--	--																																											
4.	--	--	--	--																																											
5.	--	--	--	--																																											
6.	--	--	--	--																																											
7.	--	--	--	--																																											
8.	--	--	--	--																																											
9.	--	--	--	--																																											
10.	--	--	--	--																																											
Total Cover =		0																																													
Herb Stratum (Plot size: 5 ft radius)					Hydrophytic Vegetation Indicators: <input type="checkbox"/> Yes <input checked="" type="checkbox"/> No Rapid Test for Hydrophytic Vegetation <input type="checkbox"/> Yes <input checked="" type="checkbox"/> No Dominance Test is > 50% <input type="checkbox"/> Yes <input checked="" type="checkbox"/> No Prevalence Index is ≤ 3.0 * <input type="checkbox"/> Yes <input type="checkbox"/> No Morphological Adaptations (Explain) * <input type="checkbox"/> Yes <input type="checkbox"/> No Problem Hydrophytic Vegetation (Explain) * * Indicators of hydric soil and wetland hydrology must be present, unless disturbed or problematic.																																										
1.	MALVA NEGLECTA	5	Y	UPL																																											
2.	Elymus repens	5	Y	FACU																																											
3.	--	--	--	--																																											
4.	--	--	--	--																																											
5.	--	--	--	--																																											
6.	--	--	--	--																																											
7.	--	--	--	--																																											
8.	--	--	--	--																																											
9.	--	--	--	--																																											
10.	--	--	--	--																																											
11.	--	--	--	--																																											
12.	--	--	--	--																																											
13.	--	--	--	--																																											
14.	--	--	--	--																																											
15.	--	--	--	--																																											
Total Cover =		10																																													
Woody Vine Stratum (Plot size: 30 ft radius)					Definitions of Vegetation Strata: <p style="margin-left: 40px;">Tree - Woody plants 3 in. (7.6cm) or more in diameter at breast height (DBH), regardless of height.</p> <p style="margin-left: 40px;">Sapling/Shrub - Woody plants less than 3 in. DBH and greater than 3.28 ft. tall.</p> <p style="margin-left: 40px;">Herb - All herbaceous (non-woody) plants, regardless of size, and woody plants less than 3.28 ft. tall.</p> <p style="margin-left: 40px;">Woody Vines - All woody vines greater than 3.28 ft. in height.</p>																																										
1.	--	--	--	--																																											
2.	--	--	--	--																																											
3.	--	--	--	--																																											
4.	--	--	--	--																																											
5.	--	--	--	--																																											
Total Cover =		0																																													
Remarks: Agricultural soybean commodity successfully harvested.																																															

Additional Remarks:

Sample point located in minor depression, identified as an NWI. The sample point is in a successfully cropped field, lacking hydrophytic and hydric soil indicators. Secondary hydrologic indicators suggest the area does pond with water, however; not long enough to create wetland conditions. The sample point is not a wetland feature.

Project/Site: Harmony Solar Array		Stantec Project #: 193704812	Date: 10/20/16
Applicant: Harmony Solar ND LLC			County: Cass
Investigator #1: Joseph Sander		Investigator #2:	State: North Dakota
Soil Unit: I482A Overly-Bearden silt loams	NW1 Classification: None		Wetland ID: N/A
Landform: Flats	Local Relief: Concave		Sample Point: U18
Slope (%): 0-2	Latitude: --	Longitude: --	Datum: NAD 83
Are climatic/hydrologic conditions on the site typical for this time of year? (If no, explain in remarks) <input checked="" type="checkbox"/> Yes <input type="checkbox"/> No			Community ID: Agricultural commodity
Are Vegetation <input checked="" type="checkbox"/> , Soil <input checked="" type="checkbox"/> , or Hydrology <input checked="" type="checkbox"/> significantly disturbed?		Are normal circumstances present? <input type="checkbox"/> Yes <input checked="" type="checkbox"/> No	
Are Vegetation <input type="checkbox"/> , Soil <input type="checkbox"/> , or Hydrology <input type="checkbox"/> naturally problematic? <input type="checkbox"/> Yes <input checked="" type="checkbox"/> No		Township: 140N	
		Range: \$1W Dir: --	

SUMMARY OF FINDINGS

Hydrophytic Vegetation Present? <input type="checkbox"/> Yes <input checked="" type="checkbox"/> No	Hydric Soils Present? <input type="checkbox"/> Yes <input checked="" type="checkbox"/> No
Wetland Hydrology Present? <input type="checkbox"/> Yes <input checked="" type="checkbox"/> No	Is This Sampling Point Within A Wetland? <input checked="" type="checkbox"/> Yes <input type="checkbox"/> No

Remarks: **Sample point is located in a successfully cropped area of an agricultural field subjected to frequent tilling.**

HYDROLOGY

Wetland Hydrology Indicators (Check here if indicators are not present):

<p><u>Primary:</u></p> <ul style="list-style-type: none"> <input type="checkbox"/> A1 - Surface Water <input type="checkbox"/> A2 - High Water Table <input type="checkbox"/> A3 - Saturation <input type="checkbox"/> B1 - Water Marks <input type="checkbox"/> B2 - Sediment Deposits <input type="checkbox"/> B3 - Drift Deposits <input type="checkbox"/> B4 - Algal Mat or Crust <input type="checkbox"/> B5 - Iron Deposits <input type="checkbox"/> B7 - Inundation Visible on Aerial Imagery <input type="checkbox"/> B9 - Water Stained Leaves 	<ul style="list-style-type: none"> <input type="checkbox"/> B11 - Salt Crust <input type="checkbox"/> B13 - Aquatic Invertebrates <input type="checkbox"/> C1 - Hydrogen Sulfide Odor <input type="checkbox"/> C2 - Dry-Season Water Table <input type="checkbox"/> C3 - Oxidized Rhizospheres on Living Roots (where not tilled) <input type="checkbox"/> C4 - Presence of Reduced Iron <input type="checkbox"/> C7 - Thin Muck Surface <input type="checkbox"/> Other (Explain in Remarks) 	<p><u>Secondary:</u></p> <ul style="list-style-type: none"> <input type="checkbox"/> B6 - Surface Soil Cracks <input type="checkbox"/> B8 - Sparsely Vegetated Concave Surface <input type="checkbox"/> B10 - Drainage Patterns <input type="checkbox"/> C3 - Oxidized Rhizospheres on Living Roots (where tilled) <input type="checkbox"/> C8 - Crayfish Burrows <input type="checkbox"/> C9 - Saturation Visible on Aerial Imagery <input checked="" type="checkbox"/> D2 - Geomorphic Position <input type="checkbox"/> D5 - FAC-Neutral Test <input type="checkbox"/> D7 - Frost-Heave Hummocks (LRR F)
---	--	--

Field Observations:

Surface Water Present? <input type="checkbox"/> Yes <input checked="" type="checkbox"/> No	Depth: 0 (in.)	Wetland Hydrology Present? <input type="checkbox"/> Yes <input checked="" type="checkbox"/> No
Water Table Present? <input type="checkbox"/> Yes <input checked="" type="checkbox"/> No	Depth: >24 (in.)	
Saturation Present? <input type="checkbox"/> Yes <input checked="" type="checkbox"/> No	Depth: >24 (in.)	

Describe Recorded Data (stream gauge, monitoring well, aerial photos, previous inspections), if available: **N/A**

Remarks: **Sample point is located in a minor swale with 1% slope differentiation from topographical surroundings.**

SOILS

Map Unit Name: **I482A Overly-Bearden silt loams** Series Drainage Class: **Moderately well drained**

Taxonomy (Subgroup):

Profile Description (Describe to the depth needed to document the indicator or confirm the absence of indicators.) (Type: C=Concentration, D=Depletion, RM=Reduced Matrix, CS=Covered/Coated Sand Grains, Location: PL=Pore Lining, M=Matrix)

Top Depth	Bottom Depth	Horizon	Matrix			Redox Features				Texture (e.g. clay, sand, loam)	
			Color (Moist)	%		Color (Moist)	%	Type	Location		
0	8	Ap	10YR	2/1	100	--	None	--	--	--	silt loam
8	24	A	10YR	2/1	100	--	None	--	--	--	silt loam
--	--	--	--	--	--	--	--	--	--	--	--
--	--	--	--	--	--	--	--	--	--	--	--
--	--	--	--	--	--	--	--	--	--	--	--
--	--	--	--	--	--	--	--	--	--	--	--
--	--	--	--	--	--	--	--	--	--	--	--

NRCS Hydric Soil Field Indicators (check here if indicators are not present):

<ul style="list-style-type: none"> <input type="checkbox"/> A1 - Histosol <input type="checkbox"/> A2 - Histic Epipedon <input type="checkbox"/> A3 - Black Histic <input type="checkbox"/> A4 - Hydrogen Sulfide <input type="checkbox"/> A5 - Stratified Layers (LRR F) <input type="checkbox"/> A9 - 1 cm Muck (LRR F, G, H) <input type="checkbox"/> A11 - Depleted Below Dark Surface <input type="checkbox"/> A12 - Thick Dark Surface <input type="checkbox"/> S1 - Sandy Muck Mineral <input type="checkbox"/> S2 - 2.5 cm Mucky Peat or Peat (LRR G, H) 	<ul style="list-style-type: none"> <input type="checkbox"/> S3 - 5cm Mucky Peat or Peat (LRR F) <input type="checkbox"/> S4 - Sandy Gleyed Matrix <input type="checkbox"/> S5 - Sandy Redox <input type="checkbox"/> S6 - Stripped Matrix <input type="checkbox"/> F1 - Loamy Mucky Mineral <input type="checkbox"/> F2 Loamy Gleyed Matrix <input type="checkbox"/> F3 - Depleted Matrix <input type="checkbox"/> F6 - Redox Dark Surface <input type="checkbox"/> F7 - Depleted Dark Surface <input type="checkbox"/> F8 - Redox Depressions 	<ul style="list-style-type: none"> <input type="checkbox"/> F16 - High Plains Depressions (MLRA 72, 73 of LRR H) <input type="checkbox"/> A9 - 1cm Muck (LRR I, J) <input type="checkbox"/> A16 - Coast Prairie Redox (LRR F, G, H) <input type="checkbox"/> S7 - Dark Surface (LRR G) <input type="checkbox"/> F16 - High Plains Depressions (LRR H outside MLRA 72, 73) <input type="checkbox"/> F18 - Reduced Vertic <input type="checkbox"/> TF2 - Red Parent Material <input type="checkbox"/> TF12 - Very Shallow Dark Surface <input type="checkbox"/> Other (Explain in Remarks)
--	--	---

Restrictive Layer (If Observed) Type: **N/A** Depth: **N/A** **Hydric Soil Present?** Yes No

Remarks: **The only applicable hydric soil indicator beyond 12" is "Thick Dark Surface (A12)," for which this sample point does not meet the requirements.**

¹ Indicators of hydrophytic vegetation and wetland hydrology must be present, unless disturbed or problematic.

Project/Site: **Harmony Solar Array** Wetland ID: **N/A** Sample Point **U18**
VEGETATION (Species identified in all uppercase are non-native species.)

Tree Stratum (Plot size: 30 ft radius)					Dominance Test Worksheet Number of Dominant Species that are OBL, FACW, or FAC: <u>0</u> (A) Total Number of Dominant Species Across All Strata: <u>1</u> (B) Percent of Dominant Species That Are OBL, FACW, or FAC: <u>0.0%</u> (A/B)																																										
1.	Species Name	% Cover	Dominant	Ind. Status																																											
2.	--	--	--	--																																											
3.	--	--	--	--																																											
4.	--	--	--	--																																											
5.	--	--	--	--																																											
6.	--	--	--	--																																											
7.	--	--	--	--																																											
8.	--	--	--	--																																											
9.	--	--	--	--																																											
Total Cover =		0																																													
Sapling/Shrub Stratum (Plot size: 15 ft radius)					Prevalence Index Worksheet Total % Cover of: <table style="margin-left: 20px; border-collapse: collapse;"> <tr> <td style="padding-right: 10px;">OBL spp.</td> <td style="border-bottom: 1px solid black; width: 50px; text-align: center;">0</td> <td style="padding: 0 10px;">x</td> <td style="border-bottom: 1px solid black; width: 50px; text-align: center;">1</td> <td style="padding: 0 10px;">=</td> <td style="border-bottom: 1px solid black; width: 50px; text-align: center;">0</td> </tr> <tr> <td>FACW spp.</td> <td style="border-bottom: 1px solid black; text-align: center;">0</td> <td>x</td> <td style="border-bottom: 1px solid black; text-align: center;">2</td> <td>=</td> <td style="border-bottom: 1px solid black; text-align: center;">0</td> </tr> <tr> <td>FAC spp.</td> <td style="border-bottom: 1px solid black; text-align: center;">0</td> <td>x</td> <td style="border-bottom: 1px solid black; text-align: center;">3</td> <td>=</td> <td style="border-bottom: 1px solid black; text-align: center;">0</td> </tr> <tr> <td>FACU spp.</td> <td style="border-bottom: 1px solid black; text-align: center;">0</td> <td>x</td> <td style="border-bottom: 1px solid black; text-align: center;">4</td> <td>=</td> <td style="border-bottom: 1px solid black; text-align: center;">0</td> </tr> <tr> <td>UPL spp.</td> <td style="border-bottom: 1px solid black; text-align: center;">10</td> <td>x</td> <td style="border-bottom: 1px solid black; text-align: center;">5</td> <td>=</td> <td style="border-bottom: 1px solid black; text-align: center;">50</td> </tr> <tr> <td colspan="2" style="padding-top: 10px;">Total</td> <td style="padding-top: 10px;">10</td> <td style="padding-top: 10px;">(A)</td> <td></td> <td style="padding-top: 10px;">50</td> </tr> <tr> <td colspan="2"></td> <td colspan="2"></td> <td style="padding-top: 10px;">Prevalence Index = B/A =</td> <td style="padding-top: 10px;"><u>5.000</u></td> </tr> </table>	OBL spp.	0	x	1	=	0	FACW spp.	0	x	2	=	0	FAC spp.	0	x	3	=	0	FACU spp.	0	x	4	=	0	UPL spp.	10	x	5	=	50	Total		10	(A)		50					Prevalence Index = B/A =	<u>5.000</u>
OBL spp.	0	x	1	=		0																																									
FACW spp.	0	x	2	=		0																																									
FAC spp.	0	x	3	=		0																																									
FACU spp.	0	x	4	=		0																																									
UPL spp.	10	x	5	=		50																																									
Total		10	(A)			50																																									
				Prevalence Index = B/A =		<u>5.000</u>																																									
1.	--	--	--	--																																											
2.	--	--	--	--																																											
3.	--	--	--	--																																											
4.	--	--	--	--																																											
5.	--	--	--	--																																											
6.	--	--	--	--																																											
7.	--	--	--	--																																											
8.	--	--	--	--																																											
9.	--	--	--	--																																											
10.	--	--	--	--																																											
Total Cover =		0																																													
Herb Stratum (Plot size: 5 ft radius)					Hydrophytic Vegetation Indicators: <input type="checkbox"/> Yes <input checked="" type="checkbox"/> No Rapid Test for Hydrophytic Vegetation <input type="checkbox"/> Yes <input checked="" type="checkbox"/> No Dominance Test is > 50% <input type="checkbox"/> Yes <input checked="" type="checkbox"/> No Prevalence Index is ≤ 3.0 * <input type="checkbox"/> Yes <input type="checkbox"/> No Morphological Adaptations (Explain) * <input type="checkbox"/> Yes <input type="checkbox"/> No Problem Hydrophytic Vegetation (Explain) * * Indicators of hydric soil and wetland hydrology must be present, unless disturbed or problematic.																																										
1.	ZEA MAYS	10	Y	UPL																																											
2.	--	--	--	--																																											
3.	--	--	--	--																																											
4.	--	--	--	--																																											
5.	--	--	--	--																																											
6.	--	--	--	--																																											
7.	--	--	--	--																																											
8.	--	--	--	--																																											
9.	--	--	--	--																																											
10.	--	--	--	--																																											
11.	--	--	--	--																																											
12.	--	--	--	--																																											
13.	--	--	--	--																																											
14.	--	--	--	--																																											
15.	--	--	--	--																																											
Total Cover =		10																																													
Woody Vine Stratum (Plot size: 30 ft radius)					Definitions of Vegetation Strata: <p style="margin-left: 40px;">Tree - Woody plants 3 in. (7.6cm) or more in diameter at breast height (DBH), regardless of height.</p> <p style="margin-left: 40px;">Sapling/Shrub - Woody plants less than 3 in. DBH and greater than 3.28 ft. tall.</p> <p style="margin-left: 40px;">Herb - All herbaceous (non-woody) plants, regardless of size, and woody plants less than 3.28 ft. tall.</p> <p style="margin-left: 40px;">Woody Vines - All woody vines greater than 3.28 ft. in height.</p>																																										
1.	--	--	--	--																																											
2.	--	--	--	--																																											
3.	--	--	--	--																																											
4.	--	--	--	--																																											
5.	--	--	--	--																																											
Total Cover =		0																																													
Remarks: Agricultural corn commodity successfully harvested.																																															

Additional Remarks:

Sample point located in a minor swale identified as a wet signature from aerial imagery. The sample point is in a successfully cropped field, lacking hydrophytic, hydrologic, and hydric soil indicators. The sample point is not a wetland feature.

Project/Site: Harmony Solar Array	Stantec Project #: 193704812	Date: 10/20/16
Applicant: Harmony Solar ND LLC		County: Cass
Investigator #1: Joseph Sander	Investigator #2:	State: North Dakota
Soil Unit: 1482A Overly-Bearden silt loams	NWI Classification: None	Wetland ID: N/A
Landform: Flats	Local Relief: Concave	Sample Point: U19
Slope (%): 0-2	Latitude: --	Longitude: --
		Datum: NAD 83
Are climatic/hydrologic conditions on the site typical for this time of year? (If no, explain in remarks) <input checked="" type="checkbox"/> Yes <input type="checkbox"/> No		Community ID: Agricultural commodity
Are Vegetation <input checked="" type="checkbox"/> , Soil <input checked="" type="checkbox"/> , or Hydrology <input checked="" type="checkbox"/> significantly disturbed?	Are normal circumstances present?	Section: 11
Are Vegetation <input type="checkbox"/> , Soil <input type="checkbox"/> , or Hydrology <input type="checkbox"/> naturally problematic?	<input type="checkbox"/> Yes <input checked="" type="checkbox"/> No	Township: 140N
		Range: \$1W Dir: --

SUMMARY OF FINDINGS

Hydrophytic Vegetation Present? <input type="checkbox"/> Yes <input checked="" type="checkbox"/> No	Hydric Soils Present? <input type="checkbox"/> Yes <input checked="" type="checkbox"/> No
Wetland Hydrology Present? <input type="checkbox"/> Yes <input checked="" type="checkbox"/> No	Is This Sampling Point Within A Wetland? <input checked="" type="checkbox"/> Yes <input type="checkbox"/> No

Remarks: **Sample point is located in a successfully cropped area of an agricultural field subjected to frequent tilling.**

HYDROLOGY

Wetland Hydrology Indicators (Check here if indicators are not present):

<p><u>Primary:</u></p> <ul style="list-style-type: none"> <input type="checkbox"/> A1 - Surface Water <input type="checkbox"/> A2 - High Water Table <input type="checkbox"/> A3 - Saturation <input type="checkbox"/> B1 - Water Marks <input type="checkbox"/> B2 - Sediment Deposits <input type="checkbox"/> B3 - Drift Deposits <input type="checkbox"/> B4 - Algal Mat or Crust <input type="checkbox"/> B5 - Iron Deposits <input type="checkbox"/> B7 - Inundation Visible on Aerial Imagery <input type="checkbox"/> B9 - Water Stained Leaves 	<ul style="list-style-type: none"> <input type="checkbox"/> B11 - Salt Crust <input type="checkbox"/> B13 - Aquatic Invertebrates <input type="checkbox"/> C1 - Hydrogen Sulfide Odor <input type="checkbox"/> C2 - Dry-Season Water Table <input type="checkbox"/> C3 - Oxidized Rhizospheres on Living Roots (where not tilled) <input type="checkbox"/> C4 - Presence of Reduced Iron <input type="checkbox"/> C7 - Thin Muck Surface <input type="checkbox"/> Other (Explain in Remarks) 	<p><u>Secondary:</u></p> <ul style="list-style-type: none"> <input type="checkbox"/> B6 - Surface Soil Cracks <input type="checkbox"/> B8 - Sparsely Vegetated Concave Surface <input type="checkbox"/> B10 - Drainage Patterns <input type="checkbox"/> C3 - Oxidized Rhizospheres on Living Roots (where tilled) <input type="checkbox"/> C8 - Crayfish Burrows <input type="checkbox"/> C9 - Saturation Visible on Aerial Imagery <input checked="" type="checkbox"/> D2 - Geomorphic Position <input type="checkbox"/> D5 - FAC-Neutral Test <input type="checkbox"/> D7 - Frost-Heave Hummocks (LRR F)
---	--	--

Field Observations:

Surface Water Present? <input type="checkbox"/> Yes <input checked="" type="checkbox"/> No	Depth: 0 (in.)	Wetland Hydrology Present? <input type="checkbox"/> Yes <input checked="" type="checkbox"/> No
Water Table Present? <input type="checkbox"/> Yes <input checked="" type="checkbox"/> No	Depth: >24 (in.)	
Saturation Present? <input type="checkbox"/> Yes <input checked="" type="checkbox"/> No	Depth: >24 (in.)	

Describe Recorded Data (stream gauge, monitoring well, aerial photos, previous inspections), if available: **N/A**

Remarks: **Sample point is located near a toe slope of a section road.**

SOILS

Map Unit Name: **1482A Overly-Bearden silt loams** Series Drainage Class: **Moderately well drained**

Taxonomy (Subgroup):

Profile Description (Describe to the depth needed to document the indicator or confirm the absence of indicators.) (Type: C=Concentration, D=Depletion, RM=Reduced Matrix, CS=Covered/Coated Sand Grains, Location: PL=Pore Lining, M=Matrix)

Top Depth	Bottom Depth	Horizon	Matrix			Redox Features				Texture (e.g. clay, sand, loam)	
			Color (Moist)	%		Color (Moist)	%	Type	Location		
0	8	Ap	10YR	2/1	100	--	None	--	--	--	silt loam
8	20	A	10YR	2/1	100	--	None	--	--	--	silt loam
20	24	B	10YR	5/3	85	2.5YR	5/8	>2	C	PL	silt loam
--	--	--	--	--	--	--	--	--	--	--	--
--	--	--	--	--	--	--	--	--	--	--	--
--	--	--	--	--	--	--	--	--	--	--	--
--	--	--	--	--	--	--	--	--	--	--	--

NRCS Hydric Soil Field Indicators (check here if indicators are not present):

<ul style="list-style-type: none"> <input type="checkbox"/> A1 - Histosol <input type="checkbox"/> A2 - Histic Epipedon <input type="checkbox"/> A3 - Black Histic <input type="checkbox"/> A4 - Hydrogen Sulfide <input type="checkbox"/> A5 - Stratified Layers (LRR F) <input type="checkbox"/> A9 - 1 cm Muck (LRR F, G, H) <input type="checkbox"/> A11 - Depleted Below Dark Surface <input type="checkbox"/> A12 - Thick Dark Surface <input type="checkbox"/> S1 - Sandy Muck Mineral <input type="checkbox"/> S2 - 2.5 cm Mucky Peat or Peat (LRR G, H) 	<ul style="list-style-type: none"> <input type="checkbox"/> S3 - 5cm Mucky Peat or Peat (LRR F) <input type="checkbox"/> S4 - Sandy Gleyed Matrix <input type="checkbox"/> S5 - Sandy Redox <input type="checkbox"/> S6 - Stripped Matrix <input type="checkbox"/> F1 - Loamy Mucky Mineral <input type="checkbox"/> F2 Loamy Gleyed Matrix <input type="checkbox"/> F3 - Depleted Matrix <input type="checkbox"/> F6 - Redox Dark Surface <input type="checkbox"/> F7 - Depleted Dark Surface <input type="checkbox"/> F8 - Redox Depressions 	<ul style="list-style-type: none"> <input type="checkbox"/> F16 - High Plains Depressions (MLRA 72, 73 of LRR H) <input type="checkbox"/> A9 - 1cm Muck (LRR I, J) <input type="checkbox"/> A16 - Coast Prairie Redox (LRR F, G, H) <input type="checkbox"/> S7 - Dark Surface (LRR G) <input type="checkbox"/> F16 - High Plains Depressions (LRR H outside MLRA 72, 73) <input type="checkbox"/> F18 - Reduced Vertic <input type="checkbox"/> TF2 - Red Parent Material <input type="checkbox"/> TF12 - Very Shallow Dark Surface <input type="checkbox"/> Other (Explain in Remarks)
--	--	---

Restrictive Layer (If Observed) Type: **N/A** Depth: **N/A** **Hydric Soil Present?** Yes No

Remarks: **The only applicable hydric soil indicator beyond 12" is "Thick Dark Surface (A12), for which the sample point does not meet the requirements. Matrix chroma is too high while redox concentrations are few.**

¹ Indicators of hydrophytic vegetation and wetland hydrology must be present, unless disturbed or problematic.

Project/Site: **Harmony Solar Array** Wetland ID: **N/A** Sample Point **U19**
VEGETATION (Species identified in all uppercase are non-native species.)

Tree Stratum (Plot size: 30 ft radius)					Dominance Test Worksheet Number of Dominant Species that are OBL, FACW, or FAC: <u>0</u> (A) Total Number of Dominant Species Across All Strata: <u>2</u> (B) Percent of Dominant Species That Are OBL, FACW, or FAC: <u>0.0%</u> (A/B)																																										
1.	Species Name	% Cover	Dominant	Ind. Status																																											
2.	--	--	--	--																																											
3.	--	--	--	--																																											
4.	--	--	--	--																																											
5.	--	--	--	--																																											
6.	--	--	--	--																																											
7.	--	--	--	--																																											
8.	--	--	--	--																																											
9.	--	--	--	--																																											
Total Cover =		0																																													
Sapling/Shrub Stratum (Plot size: 15 ft radius)					Prevalence Index Worksheet Total % Cover of: <table style="margin-left: 20px; border-collapse: collapse;"> <tr> <td style="padding-right: 10px;">OBL spp.</td> <td style="border-bottom: 1px solid black; width: 50px; text-align: center;">0</td> <td style="padding: 0 10px;">x</td> <td style="border-bottom: 1px solid black; width: 50px; text-align: center;">1</td> <td style="padding: 0 10px;">=</td> <td style="border-bottom: 1px solid black; width: 50px; text-align: center;">0</td> </tr> <tr> <td>FACW spp.</td> <td style="border-bottom: 1px solid black; text-align: center;">0</td> <td>x</td> <td style="border-bottom: 1px solid black; text-align: center;">2</td> <td>=</td> <td style="border-bottom: 1px solid black; text-align: center;">0</td> </tr> <tr> <td>FAC spp.</td> <td style="border-bottom: 1px solid black; text-align: center;">0</td> <td>x</td> <td style="border-bottom: 1px solid black; text-align: center;">3</td> <td>=</td> <td style="border-bottom: 1px solid black; text-align: center;">0</td> </tr> <tr> <td>FACU spp.</td> <td style="border-bottom: 1px solid black; text-align: center;">0</td> <td>x</td> <td style="border-bottom: 1px solid black; text-align: center;">4</td> <td>=</td> <td style="border-bottom: 1px solid black; text-align: center;">0</td> </tr> <tr> <td>UPL spp.</td> <td style="border-bottom: 1px solid black; text-align: center;">10</td> <td>x</td> <td style="border-bottom: 1px solid black; text-align: center;">5</td> <td>=</td> <td style="border-bottom: 1px solid black; text-align: center;">50</td> </tr> <tr> <td colspan="2" style="padding-top: 10px;">Total</td> <td style="padding-top: 10px;">10</td> <td style="padding-top: 10px;">(A)</td> <td></td> <td style="padding-top: 10px;">50</td> </tr> <tr> <td colspan="2"></td> <td colspan="2"></td> <td style="padding-top: 10px;">Prevalence Index = B/A =</td> <td style="padding-top: 10px;"><u>5.000</u></td> </tr> </table>	OBL spp.	0	x	1	=	0	FACW spp.	0	x	2	=	0	FAC spp.	0	x	3	=	0	FACU spp.	0	x	4	=	0	UPL spp.	10	x	5	=	50	Total		10	(A)		50					Prevalence Index = B/A =	<u>5.000</u>
OBL spp.	0	x	1	=		0																																									
FACW spp.	0	x	2	=		0																																									
FAC spp.	0	x	3	=		0																																									
FACU spp.	0	x	4	=		0																																									
UPL spp.	10	x	5	=		50																																									
Total		10	(A)			50																																									
				Prevalence Index = B/A =		<u>5.000</u>																																									
1.	--	--	--	--																																											
2.	--	--	--	--																																											
3.	--	--	--	--																																											
4.	--	--	--	--																																											
5.	--	--	--	--																																											
6.	--	--	--	--																																											
7.	--	--	--	--																																											
8.	--	--	--	--																																											
9.	--	--	--	--																																											
10.	--	--	--	--																																											
Total Cover =		0																																													
Herb Stratum (Plot size: 5 ft radius)					Hydrophytic Vegetation Indicators: <input type="checkbox"/> Yes <input checked="" type="checkbox"/> No Rapid Test for Hydrophytic Vegetation <input type="checkbox"/> Yes <input checked="" type="checkbox"/> No Dominance Test is > 50% <input type="checkbox"/> Yes <input checked="" type="checkbox"/> No Prevalence Index is ≤ 3.0 * <input type="checkbox"/> Yes <input type="checkbox"/> No Morphological Adaptations (Explain) * <input type="checkbox"/> Yes <input type="checkbox"/> No Problem Hydrophytic Vegetation (Explain) * * Indicators of hydric soil and wetland hydrology must be present, unless disturbed or problematic.																																										
1.	<i>Triticum spp.</i>	5	Y	UPL																																											
2.	<i>Bromus inermis</i>	5	Y	UPL																																											
3.	--	--	--	--																																											
4.	--	--	--	--																																											
5.	--	--	--	--																																											
6.	--	--	--	--																																											
7.	--	--	--	--																																											
8.	--	--	--	--																																											
9.	--	--	--	--																																											
10.	--	--	--	--																																											
11.	--	--	--	--																																											
12.	--	--	--	--																																											
13.	--	--	--	--																																											
14.	--	--	--	--																																											
15.	--	--	--	--																																											
Total Cover =		10																																													
Woody Vine Stratum (Plot size: 30 ft radius)					Definitions of Vegetation Strata: <p style="margin-left: 40px;">Tree - Woody plants 3 in. (7.6cm) or more in diameter at breast height (DBH), regardless of height.</p> <p style="margin-left: 40px;">Sapling/Shrub - Woody plants less than 3 in. DBH and greater than 3.28 ft. tall.</p> <p style="margin-left: 40px;">Herb - All herbaceous (non-woody) plants, regardless of size, and woody plants less than 3.28 ft. tall.</p> <p style="margin-left: 40px;">Woody Vines - All woody vines greater than 3.28 ft. in height.</p>																																										
1.	--	--	--	--																																											
2.	--	--	--	--																																											
3.	--	--	--	--																																											
4.	--	--	--	--																																											
5.	--	--	--	--																																											
Total Cover =		0																																													
Remarks: Agricultural wheat commodity successfully harvested.																																															

Additional Remarks:
Sample point located near toe slope of a section road identified as a wet signature from aerial imagery. The sample point is in a successfully cropped field, lacking hydrophytic, hydrologic, and hydric soil indicators. The sample point is not a wetland feature.

Project/Site: Harmony Solar Array		Stantec Project #: 193704812	Date: 10/20/16
Applicant: Harmony Solar ND LLC			County: Cass
Investigator #1: Joseph Sander		Investigator #2:	State: North Dakota
Soil Unit: I233A Fargo silty clay loam	NWI Classification: None	Wetland ID: N/A	Sample Point: U20
Landform: Flats	Local Relief: None	Community ID: Agricultural commodity	Section: 11
Slope (%): 0-1	Latitude: --	Longitude: --	Datum: NAD 83
Are climatic/hydrologic conditions on the site typical for this time of year? (If no, explain in remarks) <input checked="" type="checkbox"/> Yes <input type="checkbox"/> No		Are normal circumstances present? <input type="checkbox"/> Yes <input checked="" type="checkbox"/> No	
Are Vegetation <input checked="" type="checkbox"/> , Soil <input checked="" type="checkbox"/> , or Hydrology <input checked="" type="checkbox"/> significantly disturbed?		Are Vegetation <input type="checkbox"/> , Soil <input type="checkbox"/> , or Hydrology <input type="checkbox"/> naturally problematic? <input type="checkbox"/> Yes <input checked="" type="checkbox"/> No	
Township: 140N		Range: 51W Dir: --	

SUMMARY OF FINDINGS

Hydrophytic Vegetation Present? <input type="checkbox"/> Yes <input checked="" type="checkbox"/> No	Hydric Soils Present? <input type="checkbox"/> Yes <input checked="" type="checkbox"/> No
Wetland Hydrology Present? <input type="checkbox"/> Yes <input checked="" type="checkbox"/> No	Is This Sampling Point Within A Wetland? <input checked="" type="checkbox"/> Yes <input type="checkbox"/> No

Remarks: **Sample point is located in a successfully cropped area of an agricultural field subjected to frequent tilling.**

HYDROLOGY

Wetland Hydrology Indicators (Check here if indicators are not present):

<p><u>Primary:</u></p> <ul style="list-style-type: none"> <input type="checkbox"/> A1 - Surface Water <input type="checkbox"/> A2 - High Water Table <input type="checkbox"/> A3 - Saturation <input type="checkbox"/> B1 - Water Marks <input type="checkbox"/> B2 - Sediment Deposits <input type="checkbox"/> B3 - Drift Deposits <input type="checkbox"/> B4 - Algal Mat or Crust <input type="checkbox"/> B5 - Iron Deposits <input type="checkbox"/> B7 - Inundation Visible on Aerial Imagery <input type="checkbox"/> B9 - Water Stained Leaves 	<ul style="list-style-type: none"> <input type="checkbox"/> B11 - Salt Crust <input type="checkbox"/> B13 - Aquatic Invertebrates <input type="checkbox"/> C1 - Hydrogen Sulfide Odor <input type="checkbox"/> C2 - Dry-Season Water Table <input type="checkbox"/> C3 - Oxidized Rhizospheres on Living Roots (where not tilled) <input type="checkbox"/> C4 - Presence of Reduced Iron <input type="checkbox"/> C7 - Thin Muck Surface <input type="checkbox"/> Other (Explain in Remarks) 	<p><u>Secondary:</u></p> <ul style="list-style-type: none"> <input type="checkbox"/> B6 - Surface Soil Cracks <input type="checkbox"/> B8 - Sparsely Vegetated Concave Surface <input type="checkbox"/> B10 - Drainage Patterns <input type="checkbox"/> C3 - Oxidized Rhizospheres on Living Roots (where tilled) <input type="checkbox"/> C8 - Crayfish Burrows <input type="checkbox"/> C9 - Saturation Visible on Aerial Imagery <input type="checkbox"/> D2 - Geomorphic Position <input type="checkbox"/> D5 - FAC-Neutral Test <input type="checkbox"/> D7 - Frost-Heave Hummocks (LRR F)
---	--	---

Field Observations:

Surface Water Present? <input type="checkbox"/> Yes <input checked="" type="checkbox"/> No	Depth: 0 (in.)	Wetland Hydrology Present? <input type="checkbox"/> Yes <input checked="" type="checkbox"/> No
Water Table Present? <input type="checkbox"/> Yes <input checked="" type="checkbox"/> No	Depth: >24 (in.)	
Saturation Present? <input type="checkbox"/> Yes <input checked="" type="checkbox"/> No	Depth: >24 (in.)	

Describe Recorded Data (stream gauge, monitoring well, aerial photos, previous inspections), if available: **N/A**

Remarks: **Sample point is located in an area with no topological relief.**

SOILS

Map Unit Name: **I233A Fargo silty clay loam** Series Drainage Class: **Poorly drained**

Taxonomy (Subgroup):

Profile Description (Describe to the depth needed to document the indicator or confirm the absence of indicators.) (Type: C=Concentration, D=Depletion, RM=Reduced Matrix, CS=Covered/Coated Sand Grains, Location: PL=Pore Lining, M=Matrix)

Top Depth	Bottom Depth	Horizon	Matrix			Redox Features				Texture (e.g. clay, sand, loam)	
			Color (Moist)	%		Color (Moist)	%	Type	Location		
0	8	Ap	10YR	2/1	100	--	None	--	--	--	silty clay loam
8	24	A	10YR	2/1	100	--	None	--	--	--	silty clay loam
--	--	--	--	--	--	--	--	--	--	--	--
--	--	--	--	--	--	--	--	--	--	--	--
--	--	--	--	--	--	--	--	--	--	--	--
--	--	--	--	--	--	--	--	--	--	--	--
--	--	--	--	--	--	--	--	--	--	--	--

NRCS Hydric Soil Field Indicators (check here if indicators are not present):

<ul style="list-style-type: none"> <input type="checkbox"/> A1 - Histosol <input type="checkbox"/> A2 - Histic Epipedon <input type="checkbox"/> A3 - Black Histic <input type="checkbox"/> A4 - Hydrogen Sulfide <input type="checkbox"/> A5 - Stratified Layers (LRR F) <input type="checkbox"/> A9 - 1 cm Muck (LRR F, G, H) <input type="checkbox"/> A11 - Depleted Below Dark Surface <input type="checkbox"/> A12 - Thick Dark Surface <input type="checkbox"/> S1 - Sandy Muck Mineral <input type="checkbox"/> S2 - 2.5 cm Mucky Peat or Peat (LRR G, H) 	<ul style="list-style-type: none"> <input type="checkbox"/> S3 - 5cm Mucky Peat or Peat (LRR F) <input type="checkbox"/> S4 - Sandy Gleyed Matrix <input type="checkbox"/> S5 - Sandy Redox <input type="checkbox"/> S6 - Stripped Matrix <input type="checkbox"/> F1 - Loamy Mucky Mineral <input type="checkbox"/> F2 Loamy Gleyed Matrix <input type="checkbox"/> F3 - Depleted Matrix <input type="checkbox"/> F6 - Redox Dark Surface <input type="checkbox"/> F7 - Depleted Dark Surface <input type="checkbox"/> F8 - Redox Depressions 	<ul style="list-style-type: none"> <input type="checkbox"/> F16 - High Plains Depressions (MLRA 72, 73 of LRR H) <input type="checkbox"/> A9 - 1cm Muck (LRR I, J) <input type="checkbox"/> A16 - Coast Prairie Redox (LRR F, G, H) <input type="checkbox"/> S7 - Dark Surface (LRR G) <input type="checkbox"/> F16 - High Plains Depressions (LRR H outside MLRA 72, 73) <input type="checkbox"/> F18 - Reduced Vertic <input type="checkbox"/> TF2 - Red Parent Material <input type="checkbox"/> TF12 - Very Shallow Dark Surface <input type="checkbox"/> Other (Explain in Remarks)
--	--	---

¹ Indicators of hydrophytic vegetation and wetland hydrology must be present, unless disturbed or problematic.

Restrictive Layer (If Observed) Type: **N/A** Depth: **N/A** **Hydric Soil Present?** Yes No

Remarks: **The only applicable hydric soil indicator beyond 12" is "Thick Dark Surface (A12), for which the sample point does not meet the requirements.**

Project/Site: **Harmony Solar Array** Wetland ID: **N/A** Sample Point **U20**
VEGETATION (Species identified in all uppercase are non-native species.)

Tree Stratum (Plot size: 30 ft radius)					Dominance Test Worksheet Number of Dominant Species that are OBL, FACW, or FAC: <u>0</u> (A) Total Number of Dominant Species Across All Strata: <u>2</u> (B) Percent of Dominant Species That Are OBL, FACW, or FAC: <u>0.0%</u> (A/B)																												
1.	Species Name	% Cover	Dominant	Ind. Status																													
2.	--	--	--	--																													
3.	--	--	--	--																													
4.	--	--	--	--																													
5.	--	--	--	--																													
6.	--	--	--	--																													
7.	--	--	--	--																													
8.	--	--	--	--																													
9.	--	--	--	--																													
Total Cover =		0																															
Sapling/Shrub Stratum (Plot size: 15 ft radius)					Prevalence Index Worksheet Total % Cover of: <table style="margin-left: 20px; border-collapse: collapse;"> <tr> <td>OBL spp.</td><td><u>0</u></td><td>x 1 =</td><td><u>0</u></td> </tr> <tr> <td>FACW spp.</td><td><u>0</u></td><td>x 2 =</td><td><u>0</u></td> </tr> <tr> <td>FAC spp.</td><td><u>0</u></td><td>x 3 =</td><td><u>0</u></td> </tr> <tr> <td>FACU spp.</td><td><u>0</u></td><td>x 4 =</td><td><u>0</u></td> </tr> <tr> <td>UPL spp.</td><td><u>10</u></td><td>x 5 =</td><td><u>50</u></td> </tr> <tr> <td colspan="2" style="text-align: right;">Total</td> <td><u>10</u> (A)</td> <td><u>50</u> (B)</td> </tr> <tr> <td colspan="4" style="text-align: right;">Prevalence Index = B/A = <u>5.000</u></td> </tr> </table>	OBL spp.	<u>0</u>	x 1 =	<u>0</u>	FACW spp.	<u>0</u>	x 2 =	<u>0</u>	FAC spp.	<u>0</u>	x 3 =	<u>0</u>	FACU spp.	<u>0</u>	x 4 =	<u>0</u>	UPL spp.	<u>10</u>	x 5 =	<u>50</u>	Total		<u>10</u> (A)	<u>50</u> (B)	Prevalence Index = B/A = <u>5.000</u>			
OBL spp.	<u>0</u>	x 1 =	<u>0</u>																														
FACW spp.	<u>0</u>	x 2 =	<u>0</u>																														
FAC spp.	<u>0</u>	x 3 =	<u>0</u>																														
FACU spp.	<u>0</u>	x 4 =	<u>0</u>																														
UPL spp.	<u>10</u>	x 5 =	<u>50</u>																														
Total		<u>10</u> (A)	<u>50</u> (B)																														
Prevalence Index = B/A = <u>5.000</u>																																	
1.	--	--	--	--																													
2.	--	--	--	--																													
3.	--	--	--	--																													
4.	--	--	--	--																													
5.	--	--	--	--																													
6.	--	--	--	--																													
7.	--	--	--	--																													
8.	--	--	--	--																													
9.	--	--	--	--																													
10.	--	--	--	--																													
Total Cover =		0																															
Herb Stratum (Plot size: 5 ft radius)					Hydrophytic Vegetation Indicators: <input type="checkbox"/> Yes <input checked="" type="checkbox"/> No Rapid Test for Hydrophytic Vegetation <input type="checkbox"/> Yes <input checked="" type="checkbox"/> No Dominance Test is > 50% <input type="checkbox"/> Yes <input checked="" type="checkbox"/> No Prevalence Index is ≤ 3.0 * <input type="checkbox"/> Yes <input type="checkbox"/> No Morphological Adaptations (Explain) * <input type="checkbox"/> Yes <input type="checkbox"/> No Problem Hydrophytic Vegetation (Explain) * * Indicators of hydric soil and wetland hydrology must be present, unless disturbed or problematic.																												
1.	<i>Triticum spp.</i>	5	Y	UPL																													
2.	<i>Bromus inermis</i>	5	Y	UPL																													
3.	--	--	--	--																													
4.	--	--	--	--																													
5.	--	--	--	--																													
6.	--	--	--	--																													
7.	--	--	--	--																													
8.	--	--	--	--																													
9.	--	--	--	--																													
10.	--	--	--	--																													
11.	--	--	--	--																													
12.	--	--	--	--																													
13.	--	--	--	--																													
14.	--	--	--	--																													
15.	--	--	--	--																													
Total Cover =		10																															
Woody Vine Stratum (Plot size: 30 ft radius)					Definitions of Vegetation Strata: <p>Tree - Woody plants 3 in. (7.6cm) or more in diameter at breast height (DBH), regardless of height.</p> <p>Sapling/Shrub - Woody plants less than 3 in. DBH and greater than 3.28 ft. tall.</p> <p>Herb - All herbaceous (non-woody) plants, regardless of size, and woody plants less than 3.28 ft. tall.</p> <p>Woody Vines - All woody vines greater than 3.28 ft. in height.</p>																												
1.	--	--	--	--																													
2.	--	--	--	--																													
3.	--	--	--	--																													
4.	--	--	--	--																													
5.	--	--	--	--																													
Total Cover =		0																															
Remarks: Agricultural wheat commodity successfully harvested.																																	

Additional Remarks:
Sample point located in an area identified as a wet signature from aerial imagery. The sample point is in a successfully cropped field, lacking hydrophytic, hydrologic, and hydric soil indicators. The sample point is not a wetland feature.

Project/Site: Harmony Solar Array		Stantec Project #: 193704812	Date: 10/20/16
Applicant: Harmony Solar ND LLC			County: Cass
Investigator #1: Joseph Sander		Investigator #2:	State: North Dakota
Soil Unit: I233A Fargo silty clay loam	NWI Classification: PEM1A	Wetland ID: N/A	Sample Point: U21
Landform: Flats	Local Relief: None	Community ID: Agricultural commodity	Section: 11
Slope (%): 0-1	Latitude: --	Longitude: --	Datum: NAD 83
Are climatic/hydrologic conditions on the site typical for this time of year? <input checked="" type="checkbox"/> Yes <input type="checkbox"/> No		Are normal circumstances present? <input type="checkbox"/> Yes <input checked="" type="checkbox"/> No	
Are Vegetation <input checked="" type="checkbox"/> , Soil <input checked="" type="checkbox"/> , or Hydrology <input checked="" type="checkbox"/> significantly disturbed?		Are Vegetation <input type="checkbox"/> , Soil <input type="checkbox"/> , or Hydrology <input type="checkbox"/> naturally problematic? <input type="checkbox"/> Yes <input checked="" type="checkbox"/> No	
Township: 140N		Range: 51W Dir: --	

SUMMARY OF FINDINGS

Hydrophytic Vegetation Present? <input type="checkbox"/> Yes <input checked="" type="checkbox"/> No	Hydric Soils Present? <input type="checkbox"/> Yes <input checked="" type="checkbox"/> No
Wetland Hydrology Present? <input type="checkbox"/> Yes <input checked="" type="checkbox"/> No	Is This Sampling Point Within A Wetland? <input checked="" type="checkbox"/> Yes <input type="checkbox"/> No

Remarks: **Sample point is located in a successfully cropped area of an agricultural field subjected to frequent tilling.**

HYDROLOGY

Wetland Hydrology Indicators (Check here if indicators are not present):

<p><u>Primary:</u></p> <ul style="list-style-type: none"> <input type="checkbox"/> A1 - Surface Water <input type="checkbox"/> A2 - High Water Table <input type="checkbox"/> A3 - Saturation <input type="checkbox"/> B1 - Water Marks <input type="checkbox"/> B2 - Sediment Deposits <input type="checkbox"/> B3 - Drift Deposits <input type="checkbox"/> B4 - Algal Mat or Crust <input type="checkbox"/> B5 - Iron Deposits <input type="checkbox"/> B7 - Inundation Visible on Aerial Imagery <input type="checkbox"/> B9 - Water Stained Leaves 	<ul style="list-style-type: none"> <input type="checkbox"/> B11 - Salt Crust <input type="checkbox"/> B13 - Aquatic Invertebrates <input type="checkbox"/> C1 - Hydrogen Sulfide Odor <input type="checkbox"/> C2 - Dry-Season Water Table <input type="checkbox"/> C3 - Oxidized Rhizospheres on Living Roots (where not tilled) <input type="checkbox"/> C4 - Presence of Reduced Iron <input type="checkbox"/> C7 - Thin Muck Surface <input type="checkbox"/> Other (Explain in Remarks) 	<p><u>Secondary:</u></p> <ul style="list-style-type: none"> <input type="checkbox"/> B6 - Surface Soil Cracks <input type="checkbox"/> B8 - Sparsely Vegetated Concave Surface <input type="checkbox"/> B10 - Drainage Patterns <input type="checkbox"/> C3 - Oxidized Rhizospheres on Living Roots (where tilled) <input type="checkbox"/> C8 - Crayfish Burrows <input type="checkbox"/> C9 - Saturation Visible on Aerial Imagery <input type="checkbox"/> D2 - Geomorphic Position <input type="checkbox"/> D5 - FAC-Neutral Test <input type="checkbox"/> D7 - Frost-Heave Hummocks (LRR F)
---	--	---

Field Observations:

Surface Water Present? <input type="checkbox"/> Yes <input checked="" type="checkbox"/> No	Depth: 0 (in.)	Wetland Hydrology Present? <input type="checkbox"/> Yes <input checked="" type="checkbox"/> No
Water Table Present? <input type="checkbox"/> Yes <input checked="" type="checkbox"/> No	Depth: >24 (in.)	
Saturation Present? <input type="checkbox"/> Yes <input checked="" type="checkbox"/> No	Depth: >24 (in.)	

Describe Recorded Data (stream gauge, monitoring well, aerial photos, previous inspections), if available: **N/A**

Remarks: **Sample point is located in an area with no topological relief.**

SOILS

Map Unit Name: **I233A Fargo silty clay loam** Series Drainage Class: **Poorly drained**

Taxonomy (Subgroup):

Profile Description (Describe to the depth needed to document the indicator or confirm the absence of indicators.) (Type: C=Concentration, D=Depletion, RM=Reduced Matrix, CS=Covered/Coated Sand Grains, Location: PL=Pore Lining, M=Matrix)

Top Depth	Bottom Depth	Horizon	Matrix			Redox Features				Texture (e.g. clay, sand, loam)	
			Color (Moist)	%		Color (Moist)	%	Type	Location		
0	8	Ap	10YR	2/1	100	--	None	--	--	--	silty clay loam
8	17	A	10YR	2/1	100	--	None	--	--	--	silty clay loam
17	24	B	10YR	4/1	90	--	None	--	--	--	silty clay loam
--	--	--	--	--	--	--	--	--	--	--	--
--	--	--	--	--	--	--	--	--	--	--	--
--	--	--	--	--	--	--	--	--	--	--	--
--	--	--	--	--	--	--	--	--	--	--	--

NRCS Hydric Soil Field Indicators (check here if indicators are not present):

<ul style="list-style-type: none"> <input type="checkbox"/> A1 - Histosol <input type="checkbox"/> A2 - Histic Epipedon <input type="checkbox"/> A3 - Black Histic <input type="checkbox"/> A4 - Hydrogen Sulfide <input type="checkbox"/> A5 - Stratified Layers (LRR F) <input type="checkbox"/> A9 - 1 cm Muck (LRR F, G, H) <input type="checkbox"/> A11 - Depleted Below Dark Surface <input type="checkbox"/> A12 - Thick Dark Surface <input type="checkbox"/> S1 - Sandy Muck Mineral <input type="checkbox"/> S2 - 2.5 cm Mucky Peat or Peat (LRR G, H) 	<ul style="list-style-type: none"> <input type="checkbox"/> S3 - 5cm Mucky Peat or Peat (LRR F) <input type="checkbox"/> S4 - Sandy Gleyed Matrix <input type="checkbox"/> S5 - Sandy Redox <input type="checkbox"/> S6 - Stripped Matrix <input type="checkbox"/> F1 - Loamy Mucky Mineral <input type="checkbox"/> F2 Loamy Gleyed Matrix <input type="checkbox"/> F3 - Depleted Matrix <input type="checkbox"/> F6 - Redox Dark Surface <input type="checkbox"/> F7 - Depleted Dark Surface <input type="checkbox"/> F8 - Redox Depressions 	<ul style="list-style-type: none"> <input type="checkbox"/> F16 - High Plains Depressions (MLRA 72, 73 of LRR H) <input type="checkbox"/> A9 - 1cm Muck (LRR I, J) <input type="checkbox"/> A16 - Coast Prairie Redox (LRR F, G, H) <input type="checkbox"/> S7 - Dark Surface (LRR G) <input type="checkbox"/> F16 - High Plains Depressions (LRR H outside MLRA 72, 73) <input type="checkbox"/> F18 - Reduced Vertic <input type="checkbox"/> TF2 - Red Parent Material <input type="checkbox"/> TF12 - Very Shallow Dark Surface <input type="checkbox"/> Other (Explain in Remarks)
--	--	---

Restrictive Layer (If Observed) Type: **N/A** Depth: **N/A** **Hydric Soil Present?** Yes No

Remarks: **The only applicable hydric soil indicator beyond 12" is "Thick Dark Surface (A12), for which the sample point does not meet the requirements. There are no redox concentrations associated with horizon B.**

¹ Indicators of hydrophytic vegetation and wetland hydrology must be present, unless disturbed or problematic.

Project/Site: **Harmony Solar Array** Wetland ID: **N/A** Sample Point **U21**
VEGETATION (Species identified in all uppercase are non-native species.)

Tree Stratum (Plot size: 30 ft radius)				
	Species Name	% Cover	Dominant	Ind. Status
1.	--	--	--	--
2.	--	--	--	--
3.	--	--	--	--
4.	--	--	--	--
5.	--	--	--	--
6.	--	--	--	--
7.	--	--	--	--
8.	--	--	--	--
9.	--	--	--	--
10.	--	--	--	--
Total Cover =		0		

Dominance Test Worksheet	
Number of Dominant Species that are OBL, FACW, or FAC:	<u>0</u> (A)
Total Number of Dominant Species Across All Strata:	<u>1</u> (B)
Percent of Dominant Species That Are OBL, FACW, or FAC:	<u>0.0%</u> (A/B)

Sapling/Shrub Stratum (Plot size: 15 ft radius)				
	Species Name	% Cover	Dominant	Ind. Status
1.	--	--	--	--
2.	--	--	--	--
3.	--	--	--	--
4.	--	--	--	--
5.	--	--	--	--
6.	--	--	--	--
7.	--	--	--	--
8.	--	--	--	--
9.	--	--	--	--
10.	--	--	--	--
Total Cover =		0		

Prevalence Index Worksheet	
Total % Cover of:	Multiply by:
OBL spp. <u>0</u>	x 1 = <u>0</u>
FACW spp. <u>0</u>	x 2 = <u>0</u>
FAC spp. <u>0</u>	x 3 = <u>0</u>
FACU spp. <u>0</u>	x 4 = <u>0</u>
UPL spp. <u>5</u>	x 5 = <u>25</u>
Total <u>5</u> (A)	<u>25</u> (B)
Prevalence Index = B/A = <u>5.000</u>	

Herb Stratum (Plot size: 5 ft radius)				
	Species Name	% Cover	Dominant	Ind. Status
1.	GLYCINE MAX	5	Y	UPL
2.	--	--	--	--
3.	--	--	--	--
4.	--	--	--	--
5.	--	--	--	--
6.	--	--	--	--
7.	--	--	--	--
8.	--	--	--	--
9.	--	--	--	--
10.	--	--	--	--
11.	--	--	--	--
12.	--	--	--	--
13.	--	--	--	--
14.	--	--	--	--
15.	--	--	--	--
Total Cover =		5		

Hydrophytic Vegetation Indicators:		
<input type="checkbox"/> Yes	<input checked="" type="checkbox"/> No	Rapid Test for Hydrophytic Vegetation
<input type="checkbox"/> Yes	<input checked="" type="checkbox"/> No	Dominance Test is > 50%
<input type="checkbox"/> Yes	<input checked="" type="checkbox"/> No	Prevalence Index is ≤ 3.0 *
<input type="checkbox"/> Yes	<input type="checkbox"/> No	Morphological Adaptations (Explain) *
<input type="checkbox"/> Yes	<input type="checkbox"/> No	Problem Hydrophytic Vegetation (Explain) *

* Indicators of hydric soil and wetland hydrology must be present, unless disturbed or problematic.

Woody Vine Stratum (Plot size: 30 ft radius)				
	Species Name	% Cover	Dominant	Ind. Status
1.	--	--	--	--
2.	--	--	--	--
3.	--	--	--	--
4.	--	--	--	--
5.	--	--	--	--
Total Cover =		0		

Definitions of Vegetation Strata:	
Tree	- Woody plants 3 in. (7.6cm) or more in diameter at breast height (DBH), regardless of height.
Sapling/Shrub	- Woody plants less than 3 in. DBH and greater than 3.28 ft. tall.
Herb	- All herbaceous (non-woody) plants, regardless of size, and woody plants less than 3.28 ft. tall.
Woody Vines	- All woody vines greater than 3.28 ft. in height.

 Remarks: **Agricultural soybean commodity successfully harvested.**

Hydrophytic Vegetation Present	<input type="checkbox"/> Yes	<input checked="" type="checkbox"/> No
---------------------------------------	------------------------------	--

Additional Remarks:

Sample point located in an area identified as a NWI feature. The sample point is in a successfully cropped field, lacking hydrophytic, hydrologic, and hydric soil indicators. The sample point is not a wetland feature.

Project/Site: Harmony Solar Array		Stantec Project #: 193704812	Date: 10/20/16
Applicant: Harmony Solar ND LLC			County: Cass
Investigator #1: Joseph Sander		Investigator #2:	State: North Dakota
Soil Unit: I373A Kindred-Bearden silty clay loams	NWI Classification: R4SBCx	Local Relief: Concave	Wetland ID: N/A
Landform: Swailes, Flats	Latitude: --	Longitude: --	Sample Point: W1
Slope (%): 0-2	Datum: NAD 83		Community ID:
Are climatic/hydrologic conditions on the site typical for this time of year? (If no, explain in remarks) <input checked="" type="checkbox"/> Yes <input type="checkbox"/> No			Section: 11
Are Vegetation <input type="checkbox"/> , Soil <input type="checkbox"/> , or Hydrology <input type="checkbox"/> significantly disturbed?		Are normal circumstances present? <input checked="" type="checkbox"/> Yes <input type="checkbox"/> No	
Are Vegetation <input type="checkbox"/> , Soil <input type="checkbox"/> , or Hydrology <input type="checkbox"/> naturally problematic? <input type="checkbox"/> Yes <input type="checkbox"/> No		Township: 140N	
		Range: \$1W Dir: --	

SUMMARY OF FINDINGS

Hydrophytic Vegetation Present? <input checked="" type="checkbox"/> Yes <input type="checkbox"/> No	Hydric Soils Present? <input checked="" type="checkbox"/> Yes <input type="checkbox"/> No
Wetland Hydrology Present? <input checked="" type="checkbox"/> Yes <input type="checkbox"/> No	Is This Sampling Point Within A Wetland? <input checked="" type="checkbox"/> Yes <input type="checkbox"/> No

Remarks: **Sample point is located on the stream bank of the Lower Branch Rush River.**

HYDROLOGY

Wetland Hydrology Indicators (Check here if indicators are not present):

<p><u>Primary:</u></p> <input type="checkbox"/> A1 - Surface Water <input type="checkbox"/> A2 - High Water Table <input checked="" type="checkbox"/> A3 - Saturation <input checked="" type="checkbox"/> B1 - Water Marks <input checked="" type="checkbox"/> B2 - Sediment Deposits <input checked="" type="checkbox"/> B3 - Drift Deposits <input type="checkbox"/> B4 - Algal Mat or Crust <input type="checkbox"/> B5 - Iron Deposits <input checked="" type="checkbox"/> B7 - Inundation Visible on Aerial Imagery <input checked="" type="checkbox"/> B9 - Water Stained Leaves	<input type="checkbox"/> B11 - Salt Crust <input type="checkbox"/> B13 - Aquatic Invertebrates <input checked="" type="checkbox"/> C1 - Hydrogen Sulfide Odor <input type="checkbox"/> C2 - Dry-Season Water Table <input type="checkbox"/> C3 - Oxidized Rhizospheres on Living Roots (where not tilled) <input type="checkbox"/> C4 - Presence of Reduced Iron <input checked="" type="checkbox"/> C7 - Thin Muck Surface <input type="checkbox"/> Other (Explain in Remarks)	<p><u>Secondary:</u></p> <input type="checkbox"/> B6 - Surface Soil Cracks <input checked="" type="checkbox"/> B8 - Sparsely Vegetated Concave Surface <input checked="" type="checkbox"/> B10 - Drainage Patterns <input type="checkbox"/> C3 - Oxidized Rhizospheres on Living Roots (where tilled) <input type="checkbox"/> C8 - Crayfish Burrows <input checked="" type="checkbox"/> C9 - Saturation Visible on Aerial Imagery <input checked="" type="checkbox"/> D2 - Geomorphic Position <input type="checkbox"/> D5 - FAC-Neutral Test <input type="checkbox"/> D7 - Frost-Heave Hummocks (LRR F)
---	--	---

Field Observations:

Surface Water Present? <input type="checkbox"/> Yes <input checked="" type="checkbox"/> No	Depth: 0 (in.)	Wetland Hydrology Present? <input checked="" type="checkbox"/> Yes <input type="checkbox"/> No
Water Table Present? <input type="checkbox"/> Yes <input checked="" type="checkbox"/> No	Depth: >12 (in.)	
Saturation Present? <input checked="" type="checkbox"/> Yes <input type="checkbox"/> No	Depth: 0 (in.)	

Describe Recorded Data (stream gauge, monitoring well, aerial photos, previous inspections), if available: **N/A**

Remarks: **Sample point is located on a stream terrace within the banks of the Lower Branch Rush River.**

SOILS

Map Unit Name: **I373A Kindred-Bearden silty clay loams** Series Drainage Class: **Moderately well drained**

Taxonomy (Subgroup):

Profile Description (Describe to the depth needed to document the indicator or confirm the absence of indicators.) (Type: C=Concentration, D=Depletion, RM=Reduced Matrix, CS=Covered/Coated Sand Grains, Location: PL=Pore Lining, M=Matrix)

Top Depth	Bottom Depth	Horizon	Matrix			Redox Features				Texture (e.g. clay, sand, loam)	
			Color (Moist)	%		Color (Moist)	%	Type	Location		
0	12	A	5GY	3/5GY	100	--	None	--	--	--	mucky loam
--	--	--	--	--	--	--	--	--	--	--	--
--	--	--	--	--	--	--	--	--	--	--	--
--	--	--	--	--	--	--	--	--	--	--	--
--	--	--	--	--	--	--	--	--	--	--	--
--	--	--	--	--	--	--	--	--	--	--	--
--	--	--	--	--	--	--	--	--	--	--	--

NRCS Hydric Soil Field Indicators (check here if indicators are not present):

<input type="checkbox"/> A1 - Histosol <input type="checkbox"/> A2 - Histic Epipedon <input type="checkbox"/> A3 - Black Histic <input checked="" type="checkbox"/> A4 - Hydrogen Sulfide <input type="checkbox"/> A5 - Stratified Layers (LRR F) <input checked="" type="checkbox"/> A9 - 1 cm Muck (LRR F, G, H) <input type="checkbox"/> A11 - Depleted Below Dark Surface <input type="checkbox"/> A12 - Thick Dark Surface <input type="checkbox"/> S1 - Sandy Muck Mineral <input type="checkbox"/> S2 - 2.5 cm Mucky Peat or Peat (LRR G, H)	<input type="checkbox"/> S3 - 5cm Mucky Peat or Peat (LRR F) <input type="checkbox"/> S4 - Sandy Gleyed Matrix <input type="checkbox"/> S5 - Sandy Redox <input type="checkbox"/> S6 - Stripped Matrix <input checked="" type="checkbox"/> F1 - Loamy Mucky Mineral <input checked="" type="checkbox"/> F2 Loamy Gleyed Matrix <input type="checkbox"/> F3 - Depleted Matrix <input type="checkbox"/> F6 - Redox Dark Surface <input type="checkbox"/> F7 - Depleted Dark Surface <input type="checkbox"/> F8 - Redox Depressions	<input type="checkbox"/> F16 - High Plains Depressions (MLRA 72, 73 of LRR H) <input type="checkbox"/> A9 - 1cm Muck (LRR I, J) <input type="checkbox"/> A16 - Coast Prairie Redox (LRR F, G, H) <input type="checkbox"/> S7 - Dark Surface (LRR G) <input type="checkbox"/> F16 - High Plains Depressions (LRR H outside MLRA 72, 73) <input type="checkbox"/> F18 - Reduced Vertic <input type="checkbox"/> TF2 - Red Parent Material <input type="checkbox"/> TF12 - Very Shallow Dark Surface <input type="checkbox"/> Other (Explain in Remarks)
--	--	---

¹ Indicators of hydrophytic vegetation and wetland hydrology must be present, unless disturbed or problematic.

Restrictive Layer (If Observed) Type: N/A	Depth: N/A	Hydric Soil Present? <input checked="" type="checkbox"/> Yes <input type="checkbox"/> No
--	-------------------	---

Remarks: **Sample point in an area frequently inundated for long periods of time and subjected to high organic matter decomposition.**

Project/Site: **Harmony Solar Array** Wetland ID: **N/A** Sample Point **W1**

VEGETATION (Species identified in all uppercase are non-native species.)

Tree Stratum (Plot size: 30 ft radius)			
	Species Name	% Cover	Ind. Status
1.	--	--	--
2.	--	--	--
3.	--	--	--
4.	--	--	--
5.	--	--	--
6.	--	--	--
7.	--	--	--
8.	--	--	--
9.	--	--	--
10.	--	--	--
Total Cover =		0	

Dominance Test Worksheet

Number of Dominant Species that are OBL, FACW, or FAC: 1 (A)

Total Number of Dominant Species Across All Strata: 1 (B)

Percent of Dominant Species That Are OBL, FACW, or FAC: 100.0% (A/B)

Sapling/Shrub Stratum (Plot size: 15 ft radius)			
	Species Name	% Cover	Ind. Status
1.	--	--	--
2.	--	--	--
3.	--	--	--
4.	--	--	--
5.	--	--	--
6.	--	--	--
7.	--	--	--
8.	--	--	--
9.	--	--	--
10.	--	--	--
Total Cover =		0	

Prevalence Index Worksheet

Total % Cover of:	Multiply by:	
OBL spp. <u>10</u>	x 1 =	<u>10</u>
FACW spp. <u>40</u>	x 2 =	<u>80</u>
FAC spp. <u>0</u>	x 3 =	<u>0</u>
FACU spp. <u>5</u>	x 4 =	<u>20</u>
UPL spp. <u>0</u>	x 5 =	<u>0</u>
Total <u>55</u> (A)		<u>110</u> (B)
Prevalence Index = B/A =		<u>2.000</u>

Herb Stratum (Plot size: 5 ft radius)			
	Species Name	% Cover	Ind. Status
1.	<i>Phalaris arundinacea</i>	40	Y FACW
2.	<i>Rumex occidentalis</i>	10	-- OBL
3.	<i>Taraxacum officinale</i>	5	-- FACU
4.	--	--	--
5.	--	--	--
6.	--	--	--
7.	--	--	--
8.	--	--	--
9.	--	--	--
10.	--	--	--
11.	--	--	--
12.	--	--	--
13.	--	--	--
14.	--	--	--
15.	--	--	--
Total Cover =		55	

Hydrophytic Vegetation Indicators:

Yes No Rapid Test for Hydrophytic Vegetation

Yes No Dominance Test is > 50%

Yes No Prevalence Index is ≤ 3.0 *

Yes No Morphological Adaptations (Explain) *

Yes No Problem Hydrophytic Vegetation (Explain) *

* Indicators of hydric soil and wetland hydrology must be present, unless disturbed or problematic.

Woody Vine Stratum (Plot size: 30 ft radius)			
	Species Name	% Cover	Ind. Status
1.	--	--	--
2.	--	--	--
3.	--	--	--
4.	--	--	--
5.	--	--	--
Total Cover =		0	

Definitions of Vegetation Strata:

Tree - Woody plants 3 in. (7.6cm) or more in diameter at breast height (DBH), regardless of height.

Sapling/Shrub - Woody plants less than 3 in. DBH and greater than 3.28 ft. tall.

Herb - All herbaceous (non-woody) plants, regardless of size, and woody plants less than 3.28 ft. tall.

Woody Vines - All woody vines greater than 3.28 ft. in height.

Remarks: **Area is sparsely vegetated due to sediment deposits and long periods of inundation.**

Additional Remarks:
Sample point located in a stream bank terrace. The sample point is a wetland feature.

Hydrophytic Vegetation Present Yes No

Project/Site: Harmony Solar Array		Stantec Project #: 193704812	Date: 10/20/16
Applicant: Harmony Solar ND LLC			County: Cass
Investigator #1: Joseph Sander		Investigator #2:	State: North Dakota
Soil Unit: I482A Overly-Bearden silty clay loams	NWI Classification: R4SBCx	Local Relief: Concave	Wetland ID: N/A
Landform: Flats	Latitude: --	Longitude: --	Sample Point: W2
Slope (%): 0-2	Datum: NAD 83		Community ID:
Are climatic/hydrologic conditions on the site typical for this time of year? (If no, explain in remarks) <input checked="" type="checkbox"/> Yes <input type="checkbox"/> No			Section: 10
Are Vegetation <input type="checkbox"/> , Soil <input type="checkbox"/> , or Hydrology <input type="checkbox"/> significantly disturbed?		Are normal circumstances present? <input checked="" type="checkbox"/> Yes <input type="checkbox"/> No	
Are Vegetation <input type="checkbox"/> , Soil <input type="checkbox"/> , or Hydrology <input type="checkbox"/> naturally problematic? <input type="checkbox"/> Yes <input type="checkbox"/> No		Township: 140N	
		Range: \$1W Dir: --	

SUMMARY OF FINDINGS

Hydrophytic Vegetation Present? <input checked="" type="checkbox"/> Yes <input type="checkbox"/> No	Hydric Soils Present? <input checked="" type="checkbox"/> Yes <input type="checkbox"/> No
Wetland Hydrology Present? <input checked="" type="checkbox"/> Yes <input type="checkbox"/> No	Is This Sampling Point Within A Wetland? <input checked="" type="checkbox"/> Yes <input type="checkbox"/> No

Remarks: **Sample point is located on the stream bank of the Lower Branch Rush River.**

HYDROLOGY

Wetland Hydrology Indicators (Check here if indicators are not present):

<p><u>Primary:</u></p> <ul style="list-style-type: none"> <input type="checkbox"/> A1 - Surface Water <input type="checkbox"/> A2 - High Water Table <input type="checkbox"/> A3 - Saturation <input type="checkbox"/> B1 - Water Marks <input checked="" type="checkbox"/> B2 - Sediment Deposits <input type="checkbox"/> B3 - Drift Deposits <input type="checkbox"/> B4 - Algal Mat or Crust <input type="checkbox"/> B5 - Iron Deposits <input type="checkbox"/> B7 - Inundation Visible on Aerial Imagery <input checked="" type="checkbox"/> B9 - Water Stained Leaves 	<ul style="list-style-type: none"> <input type="checkbox"/> B11 - Salt Crust <input type="checkbox"/> B13 - Aquatic Invertebrates <input type="checkbox"/> C1 - Hydrogen Sulfide Odor <input type="checkbox"/> C2 - Dry-Season Water Table <input type="checkbox"/> C3 - Oxidized Rhizospheres on Living Roots (where not tilled) <input type="checkbox"/> C4 - Presence of Reduced Iron <input type="checkbox"/> C7 - Thin Muck Surface <input type="checkbox"/> Other (Explain in Remarks) 	<p><u>Secondary:</u></p> <ul style="list-style-type: none"> <input checked="" type="checkbox"/> B6 - Surface Soil Cracks <input checked="" type="checkbox"/> B8 - Sparsely Vegetated Concave Surface <input checked="" type="checkbox"/> B10 - Drainage Patterns <input type="checkbox"/> C3 - Oxidized Rhizospheres on Living Roots (where tilled) <input type="checkbox"/> C8 - Crayfish Burrows <input type="checkbox"/> C9 - Saturation Visible on Aerial Imagery <input checked="" type="checkbox"/> D2 - Geomorphic Position <input type="checkbox"/> D5 - FAC-Neutral Test <input type="checkbox"/> D7 - Frost-Heave Hummocks (LRR F)
---	--	---

<p>Field Observations:</p> <p>Surface Water Present? <input type="checkbox"/> Yes <input checked="" type="checkbox"/> No Depth: 0 (in.)</p> <p>Water Table Present? <input type="checkbox"/> Yes <input checked="" type="checkbox"/> No Depth: >16 (in.)</p> <p>Saturation Present? <input type="checkbox"/> Yes <input checked="" type="checkbox"/> No Depth: >16 (in.)</p>	<p>Wetland Hydrology Present? <input checked="" type="checkbox"/> Yes <input type="checkbox"/> No</p>
---	--

Describe Recorded Data (stream gauge, monitoring well, aerial photos, previous inspections), if available: **N/A**

Remarks: **Sample point is located on a stream terrace of the Lower Branch Rush River, highly incised.**

SOILS

Map Unit Name: **I482A Overly-Bearden silty clay loams** Series Drainage Class: **Moderately well drained**

Taxonomy (Subgroup):

Profile Description (Describe to the depth needed to document the indicator or confirm the absence of indicators.) (Type: C=Concentration, D=Depletion, RM=Reduced Matrix, CS=Covered/Coated Sand Grains, Location: PL=Pore Lining, M=Matrix)

Top Depth	Bottom Depth	Horizon	Matrix			Redox Features				Texture (e.g. clay, sand, loam)	
			Color (Moist)	%		Color (Moist)	%	Type	Location		
0	10	A	10YR	2/1	100	--	None	--	--	--	silty clay loam
10	16	B	10YR	5/2	100	--	None	--	--	--	silty clay loam
--	--	--	--	--	--	--	--	--	--	--	--
--	--	--	--	--	--	--	--	--	--	--	--
--	--	--	--	--	--	--	--	--	--	--	--
--	--	--	--	--	--	--	--	--	--	--	--
--	--	--	--	--	--	--	--	--	--	--	--

NRCS Hydric Soil Field Indicators (check here if indicators are not present):

<ul style="list-style-type: none"> <input type="checkbox"/> A1 - Histosol <input type="checkbox"/> A2 - Histic Epipedon <input type="checkbox"/> A3 - Black Histic <input type="checkbox"/> A4 - Hydrogen Sulfide <input type="checkbox"/> A5 - Stratified Layers (LRR F) <input type="checkbox"/> A9 - 1 cm Muck (LRR F, G, H) <input type="checkbox"/> A11 - Depleted Below Dark Surface <input checked="" type="checkbox"/> A12 - Thick Dark Surface <input type="checkbox"/> S1 - Sandy Muck Mineral <input type="checkbox"/> S2 - 2.5 cm Mucky Peat or Peat (LRR G, H) 	<ul style="list-style-type: none"> <input type="checkbox"/> S3 - 5cm Mucky Peat or Peat (LRR F) <input type="checkbox"/> S4 - Sandy Gleyed Matrix <input type="checkbox"/> S5 - Sandy Redox <input type="checkbox"/> S6 - Stripped Matrix <input type="checkbox"/> F1 - Loamy Mucky Mineral <input type="checkbox"/> F2 Loamy Gleyed Matrix <input type="checkbox"/> F3 - Depleted Matrix <input type="checkbox"/> F6 - Redox Dark Surface <input type="checkbox"/> F7 - Depleted Dark Surface <input type="checkbox"/> F8 - Redox Depressions 	<ul style="list-style-type: none"> <input type="checkbox"/> F16 - High Plains Depressions (MLRA 72, 73 of LRR H) <input type="checkbox"/> A9 - 1cm Muck (LRR I, J) <input type="checkbox"/> A16 - Coast Prairie Redox (LRR F, G, H) <input type="checkbox"/> S7 - Dark Surface (LRR G) <input type="checkbox"/> F16 - High Plains Depressions (LRR H outside MLRA 72, 73) <input type="checkbox"/> F18 - Reduced Vertic <input type="checkbox"/> TF2 - Red Parent Material <input type="checkbox"/> TF12 - Very Shallow Dark Surface <input type="checkbox"/> Other (Explain in Remarks)
---	--	---

¹ Indicators of hydrophytic vegetation and wetland hydrology must be present, unless disturbed or problematic.

Restrictive Layer (If Observed) Type: N/A Depth: N/A	Hydric Soil Present? <input checked="" type="checkbox"/> Yes <input type="checkbox"/> No
--	---

Remarks: **Sample point located on a high terrace of a highly incised stream bank, meeting requirements of A12 for hydric soils.**

Project/Site: **Harmony Solar Array** Wetland ID: **N/A** Sample Point **W2**
VEGETATION (Species identified in all uppercase are non-native species.)

Tree Stratum (Plot size: 30 ft radius)			
	Species Name	% Cover	Ind. Status
1.	--	--	--
2.	--	--	--
3.	--	--	--
4.	--	--	--
5.	--	--	--
6.	--	--	--
7.	--	--	--
8.	--	--	--
9.	--	--	--
10.	--	--	--
Total Cover =		0	

Dominance Test Worksheet	
Number of Dominant Species that are OBL, FACW, or FAC:	<u>1</u> (A)
Total Number of Dominant Species Across All Strata:	<u>1</u> (B)
Percent of Dominant Species That Are OBL, FACW, or FAC:	<u>100.0%</u> (A/B)

Sapling/Shrub Stratum (Plot size: 15 ft radius)			
	Species Name	% Cover	Ind. Status
1.	--	--	--
2.	--	--	--
3.	--	--	--
4.	--	--	--
5.	--	--	--
6.	--	--	--
7.	--	--	--
8.	--	--	--
9.	--	--	--
10.	--	--	--
Total Cover =		0	

Prevalence Index Worksheet	
Total % Cover of:	Multiply by:
OBL spp. <u>10</u>	x 1 = <u>10</u>
FACW spp. <u>40</u>	x 2 = <u>80</u>
FAC spp. <u>0</u>	x 3 = <u>0</u>
FACU spp. <u>5</u>	x 4 = <u>20</u>
UPL spp. <u>0</u>	x 5 = <u>0</u>
Total <u>55</u> (A)	<u>110</u> (B)
Prevalence Index = B/A = <u>2.000</u>	

Herb Stratum (Plot size: 5 ft radius)			
	Species Name	% Cover	Ind. Status
1.	<i>Phalaris arundinacea</i>	40	Y FACW
2.	<i>Rumex occidentalis</i>	10	-- OBL
3.	<i>Taraxacum officinale</i>	5	-- FACU
4.	--	--	--
5.	--	--	--
6.	--	--	--
7.	--	--	--
8.	--	--	--
9.	--	--	--
10.	--	--	--
11.	--	--	--
12.	--	--	--
13.	--	--	--
14.	--	--	--
15.	--	--	--
Total Cover =		55	

Hydrophytic Vegetation Indicators:		
<input checked="" type="checkbox"/> Yes	<input type="checkbox"/> No	Rapid Test for Hydrophytic Vegetation
<input checked="" type="checkbox"/> Yes	<input type="checkbox"/> No	Dominance Test is > 50%
<input checked="" type="checkbox"/> Yes	<input type="checkbox"/> No	Prevalence Index is ≤ 3.0 *
<input checked="" type="checkbox"/> Yes	<input type="checkbox"/> No	Morphological Adaptations (Explain) *
<input type="checkbox"/> Yes	<input type="checkbox"/> No	Problem Hydrophytic Vegetation (Explain) *

* Indicators of hydric soil and wetland hydrology must be present, unless disturbed or problematic.

Woody Vine Stratum (Plot size: 30 ft radius)			
	Species Name	% Cover	Ind. Status
1.	--	--	--
2.	--	--	--
3.	--	--	--
4.	--	--	--
5.	--	--	--
Total Cover =		0	

Definitions of Vegetation Strata:	
Tree	Woody plants 3 in. (7.6cm) or more in diameter at breast height (DBH), regardless of height.
Sapling/Shrub	Woody plants less than 3 in. DBH and greater than 3.28 ft. tall.
Herb	All herbaceous (non-woody) plants, regardless of size, and woody plants less than 3.28 ft. tall.
Woody Vines	All woody vines greater than 3.28 ft. in height.

 Remarks: **Area is sparsely vegetated due to sediment deposits and long periods of inundation.**
Additional Remarks:
 Sample point located in a stream bank terrace. The sample point is a wetland feature.

Hydrophytic Vegetation Present Yes No

APPENDIX B

Site Photographs



Photo 1. USGS 1:24,000 scale topography intermittent stream and NWI classification R4SBC in Section 16. Looking north from 33rd St. SE.



Photo 2. Looking north at same drainage feature as Photo 1, 230 yards north of 33rd St. SE.



Photo 3. Looking west, general view of NE $\frac{1}{4}$ of Section 16. View exemplifies lack of topographic features indicative of Project area.



Photo 4. Looking south down drainage feature from NE $\frac{1}{4}$ of Section 16 towards the SE $\frac{1}{4}$ of Section 16.



Photo 5. View looking east at Lower Branch Rush River from 160th Avenue SE.



Photo 6. View looking east at NW $\frac{1}{4}$ of Section 10. Exemplifies lack of drainage feature aerial images suggest would run towards the horizon.



Photo 7. View of west at SW $\frac{1}{4}$ of Section 10 near Sample point u14.



Photo 8. View south at NWI feature located in NE $\frac{1}{4}$ of the NW $\frac{1}{4}$ of Section 11. Water ponds in the area but does not create hydric soils.



Photo 9. View of west at SW $\frac{1}{4}$ of Section 10 near Sample point u14.



Photo 10. View south at NE $\frac{1}{4}$ of the SE $\frac{1}{4}$ of Section 11, along 162nd Avenue south near Sample Point u19.



Photo 11. View north of NWI at SE $\frac{1}{4}$ of the NW $\frac{1}{4}$ of Section 11 near Sample point u21.



Photo 12. View north of NWI at NE $\frac{1}{4}$ of the SW $\frac{1}{4}$ of Section 10 near Sample point u15.

Harmony Solar Project
Appendix G
Vegetation Management Plan

Vegetation Management Plan for the Harmony Solar Project



Harmony Solar ND, LLC

June 2018

Prepared by:



800 Washington Avenue N, Suite 315

Minneapolis, MN 55401



21938 Mushtown Road

Prior Lake, MN 55372

Table of Contents

- 1.0 GOALS AND OBJECTIVES 3
- 2.0 VEGETATION MANAGEMENT 3
 - 2.1 Schedule** 3
 - 2.2 Seedbed Preparation**..... 3
 - 2.3 Planting Method**..... 4
 - 2.3.1 Seed Drill 4
 - 2.3.2 Broadcast..... 4
 - 2.4 Seed Source and Quality**..... 5
 - 2.5 Seeding Mixtures**..... 5
 - 2.5.1 Nurse Crop 5
 - 2.5.2 Cover Crop..... 6
 - 2.6 Mulching**..... 6
 - 2.7 Management During Establishment**..... 6
 - 2.7.1 Site-Wide Mowing..... 7
 - 2.7.2 Spot-Mowing 7
 - 2.7.3 Hand Weeding..... 7
 - 2.7.4 Spot-Spraying 7
 - 2.8 Perpetual Management**..... 8
 - 2.8.1 Mowing/Haying 8
 - 2.8.2 Grazing..... 8

Appendix A – Grazing and Mowing Vegetation Management Seed Mixes

1.0 GOALS AND OBJECTIVES

Harmony Solar ND, LLC (Harmony) is developing a 200 megawatt (MW) solar project located in Cass County, North Dakota. The Project will comprise approximately 1,600 acres in Harmony Township Sections 10, 11, and 16 (Township 140 North, Range 51 West) approximately 15 miles northwest of Fargo, North Dakota. Harmony has developed this Vegetation Management Plan (Plan) that will achieve the goals for operating the solar facility, promote pollinator habitat, establish stable ground cover, reduce erosion and runoff, and improve infiltration.

2.0 VEGETATION MANAGEMENT

2.1 Schedule

Planting will occur post-construction of the solar panels and tracking system. Planting after grading but before post and panel installation would result in poor seed germination due to equipment maneuvering. Growing season plantings should occur from May 1 - July 1 when the soil temperature is at least 60 degrees Fahrenheit or higher. However, the ideal timeframe for an early spring seeding is May 1 – June 15. Dormant seeding can be conducted after October 31 or after soil temperatures fall below 50 degrees Fahrenheit for a consistent period of time, but before soils freeze. Seeding rates may need to be increased by 25 percent for frost seeding due to lower germination rates and loss of seed that is consumed by wildlife over the winter months. If the planting is not successful, reseeding must be addressed when appropriate.

If seeding cannot be accomplished within the specified dates above, a temporary cover crop may be planted and then tilled under prior to permanent seeding, or a nurse crop may be planted with the planned seed mix. Nurse and cover crop guidance is provided below in Section 2.5.

2.2 Seedbed Preparation

The primary goals of seedbed preparation are to: 1) control weed species and 2) to provide ideal growing conditions for the seed to be established. If undesirable weed vegetation is present, it must be removed prior to seeding. An herbicide application may be appropriate provided a U.S. Environmental Protection Agency approved formulation is used consistent with labeled instructions by a licensed applicator. Herbicide should be selected and applied sufficiently in advance of seeding so as not to inhibit germination and growth of planted species. If glyphosate is used, seeding should be conducted at least 14 days after herbicide application.

Areas to be seeded will be prepared to produce a friable, smooth, firm seedbed. Conventional tillage should result in a clean tilled, smooth seedbed. Soil particles should be half an inch or smaller in the top inch of soil. Compacted soil prevents the seed from being planted at a proper depth and inhibits root penetration of new seedlings severely reducing the establishment of the planted seed. Decompaction will be conducted by tilling the site to loosen the upper four inches of soil followed by harrowing the site using a drag harrow or similar equipment.

Use of a no-till seed drill requires a firm seedbed before seeding. The seedbed is considered firm when you can walk on it without sinking more than ½ inch (sole of shoe). Firming of the seedbed after tillage operations can be achieved by rolling or cultipacking prior to planting. However, if a broadcast seeder is used for seeding, the site should be cultipacked only after seeding.

2.3 Planting Method

Native grass and forbs may be planted by seed drill or broadcast. Use of a seed drill designed specifically to plant prairie grasses and forbs typically achieves greater stand success due to maximized seed to soil contact during planting. Guidance for both planting methods are provided below.

2.3.1 Seed Drill

Native seeding is best achieved by use of a seed drill equipped with a double disc or coulter furrow openers with depth bands and press wheels, cultipacker, or drag chains. Seed should be planted ⅛ to ½ inch deep. Application in two sweeps, with the second sweep being applied at a right angle to the first, will promote even distribution of the seed. When seeding in two sweeps, calibrate the drill to apply seed at half of the required seeding rate. This method should also blend a nurse crop seed with the native seed to help distribute small, fine textured native seed evenly across the site (see nurse crops in Section 2.5.1).

When using a seed drill, the operator should always operate the drill at the recommended speed (consult manual for model specifications). Excessive ground speed will cause the drill to plant the seed improperly. The seed drill operator should inspect the drill while operating it and avoid drilling in wet conditions. If mud builds up on the depth bands it should be cleaned off because seed box feeder tubes can become clogged. Should this happen, the operator can squeeze or shake the tubes to remove lodged seed.

If the seed level drops below the agitators in the seed boxes, seed doesn't feed as efficiently, resulting in uneven seeding. The drill operator should insert additional seed into the seed boxes as necessary. Towards the end of seeding the site, if the seed level drops below the agitators, filler material similar in size to the seed can be added to the seed box to increase the volume; however, this may necessitate adjusting the seeding rate. Vermiculite, cat litter or cracked corn can be used as filler.

2.3.2 Broadcast

If the broadcast seeding method is employed, native-seed broadcasters such as a Vicon, EZEE Flow spreader, or Brillion seeder should be used as they are adapted to spread mixes with different sized seeds. Broadcast application should be performed in two sweeps of alternate directions applying half the seed in each sweep to ensure even distribution of the seed. This method should also blend a nurse crop seed with the native seed to help distribute small, fine textured native seed evenly across the site (see nurse crops in Section 2.5.1). After the seed is broadcast, it should be incorporated into the soil by using a drag harrow, dragging a piece of heavy chain, or raking in the seed with a garden rake before packing the soil with a cultipacker or lawn roller. Seeds should be planted ⅛ to ½ inch deep. Brillion seeders are equipped with both a soil conditioning implement and a cultipacker.

2.4 Seed Source and Quality

Seed and planting materials will meet state of North Dakota quality standards. All seed analyses must be conducted in accordance with the North Dakota Seed Law and Rules which specify the kind and amount of weed seed permitted, the requirements for a current analysis report and labeling of all seed to show its purity, germination, date of last germination test, and weed content.

Seed will be obtained from a local seed supplier who can verify that the seed is best adapted to the topography, hydrology, soil, and climate conditions of the site and will provide genetic compatibility with native vegetation in proximity to the Harmony Solar Project. Genetic source origin of all native seed should be from within a 200-mile radius of the site. Species should be true to their scientific name as specified. Contractor must provide Owner with seed tags or nursery confirmation of seed order prior to installing seed. The Owner will review and must approve in writing any species eliminations, substitutions, or source origin exceptions. Seeds should have proper stratification and/or scarification to break seed dormancy if planting in spring. All legumes shall be inoculated with proper rhizobia at the appropriate time prior to planting. The seed mixes selected for this site do not contain species considered noxious by federal, state, or local regulations (see Appendix A).

2.5 Seeding Mixtures

The seed mixes to be used for the Project have been developed in consultation with the Cass County Soil Conservation District. Harmony has developed two sets of native seed mixes for the Project which include a short prairie, tall prairie, and wet prairie seed mix for each set. One seed mix set is designed to be used with a vegetation management practice of traditional mowing. The other seed mix set is designed to be used with a vegetation management practice that uses sheep or lambs as grazers. Research has shown that legumes have poor survivorship under grazing pressure (they are preferred forage), so legumes in the tall and short grazing mixes are reduced to one hardy native species (partridge pea, *Chamaecrista fasciculata*) and eliminated from the wet grazing mix entirely. Tables for each seed mix are provided in Appendix A. The maintenance method has yet to be determined for the Project and will be selected prior to seed selection.

A short prairie mix will be established within the panel footprint, the tall prairie seed mix will be established in the open space between the fence and the array, and a wet prairie seed mix will be used in wet areas or areas anticipated to hold water. Both warm-season and cool-season native grasses and forbs were selected to promote pollinator habitat, enhance the diversity of native vegetation, and reduce the presence of non-native vegetation occurring in the Project Area.

2.5.1 Nurse Crop

A nurse crop should be planted with the planned seed mix to control erosion and suppress weeds. Seeding guidance is as follows:

- Spring (May 1 to July 1): 10 pounds per acre pure live seed (PLS) oats
- Fall (after October 31): 10 pounds per acre PLS winter wheat

Mowing the nurse crop before it forms a dense canopy and before it produces a seedhead will promote the growth of the native species. Winter wheat nurse crops must be mowed two or three times the following spring prior to seedhead emergence to prevent seed production and reduce long-term persistence.

2.5.2 Cover Crop

When cover crops are planted alone, pending a more favorable time to establish natives, they are called temporary cover crops. Seeding recommendations are as follows.

- Summer – 35 pounds per acre PLS oats, and one of the following warm-season species:
 - 5 pounds per acre PLS piper sudan,
 - 10 pounds per acre PLS millet (Japanese or Pearl variety), or
 - 30 pounds per acre PLS sorghum.
- Fall – 25 pounds per acre PLS winter wheat.

Cover crops should be destroyed the following spring with herbicides, tilled, or mowed two or three times to prevent seed production and competition with the native seed.

2.6 Mulching

Preventive measures should be taken to prevent soil erosion, which can wash away seed and smother new seedlings. If temporary cover crops are not used and if sufficient crop stubble is not present, MCIA Certified Weed-Free mulch should be applied at two tons per acre in upland areas. The mulch should be disk-anchored to prevent movement.

2.7 Management During Establishment

Prairie establishment in the first 2-3 years must focus on control of noxious weeds and other invasive vegetation. Species currently listed as noxious in North Dakota that should be eradicated include:

- Absinth Wormwood (*Artemisia absinthium*)
- Canada Thistle (*Cirsium arvense*)
- Dalmatian Toadflax (*Linaria genistifolia*)
- Diffuse Knapweed (*Centaurea diffusa*)
- Leafy Spurge (*Euphorbia esula*)
- Musk Thistle (*Carduus nutans*)
- Purple Loosestrife (*Lythrum salicaria*)
- Russian Knapweed (*Acroptilon repens*)
- Saltcedar (*Tamarix chinensis*, *T. parviflora*, *T. ramosissima*)
- Spotted Knapweed (*Centaurea maculosa*)
- Yellow Toadflax (*Linaria vulgaris*)

The primary establishment management tasks are site-wide mowing (to reduce shading of native seed and prevent invasive weeds from developing seed) and control of invasive weeds and all trees/shrubs that may be present by spot-mowing, hand weeding, or spot-spraying.

2.7.1 Site-Wide Mowing

During the first two growing seasons after planting, the Contractor should mow all native seeded areas to a height of 8-12” after vegetation in said areas reaches a height of approximately 30” but before non-native, invasive species go to seed. Mowing below the recommended height can damage the long-term health of the planting. Mowed vegetation should be bagged and removed off site to prevent smothering new growth. Mowing equipment should be cleaned prior to use on site to prevent the spread of non-native and invasive species into the planting. Mowing should occur two times during the first year and two times during the second year, or as necessary to achieve project goals.

2.7.2 Spot-Mowing

Spot-mowing areas where invasive or noxious weeds become established can stress these aggressive and fast growing invasive plants and prevent production of weed seed, which can allow the native species to become established. Spot-mowing should be conducted in weedy areas at a height between five and eight inches before seed is allowed to set. Spot-mowing can be done every year to ensure planting health, even following establishment years.

2.7.3 Hand Weeding

Hand weeding can be an effective method of controlling small populations of weeds. Hand weeding should be done when soils are moist, and care should be taken to avoid disturbing the root systems of desirable plants. It is also important that proper pulling technique is used to avoid injury. Tools such as Weed Wrenches and Weed Talons can be used for pulling woody plants such as buckthorn and non-native honeysuckles.

2.7.4 Spot-Spraying

Spot-spraying should target only noxious or invasive weed species. A licensed herbicide applicator should be hired to apply the appropriate herbicide(s). The Midwest Invasive Plant Control Database provides a compilation of control methods for many common invasive plants. To prevent inadvertent broadcast spraying of the planted prairie by others, it may be advantageous to place the prairie on the local “do not spray” list.

2.8 Perpetual Management

From Year 4 onwards, yearly management is required to control the establishment and spread of invasive species, combat the establishment of woody growth (trees and shrubs), and reduce biomass/fuel load onsite. This management may take the form of mowing (or haying) or grazing, depending on Owner preference and in coordination with the seed mixes selected and installed. Some degree of hand weeding and/or spot-spraying (discussed above) may continue to be warranted to maintain prairie quality and achieve project goals.

2.8.1 Mowing/Haying

Annual site-wide mowing should be done in the month of October or when prairie plants have gone dormant. Mowed vegetation should be bagged and removed off site to prevent smothering new growth; similarly, haying practices can be used. Spot-mowing may be required during the growing season if invasive species become an issue in localized areas (see above). Care should be taken during nesting season (April 1-August 1) to protect grassland birds. Mowing equipment should be cleaned prior to use on site to prevent the spread of non-native and invasive species into the planting.

2.8.2 Grazing

Harmony may use sheep or lambs as grazers to manage vegetation. Well-managed grazing can restrict woody vegetation and non-native species encroachment into grasslands, prevent excessive litter accumulation, improve forage production, and accelerate decomposition and nutrient cycling. A grazing plan should be developed defining factors such as timing, potential disturbance, herd size, water sources, and grazing objectives if this management technique is used.

Livestock should be quarantined for two days and fed with weed free hay prior to their introduction onto the prairie planting area to allow undesirable seeds to pass from their digestive system. Water should be provided to livestock to reduce trail formation within the prairie planting area.

Appendix A
Grazing and Mowing Vegetation Management
Seed Mixes

Grazing Vegetation Management
Seed Mixes

Short Prairie Mix (Array)		
Grazing Vegetation Management Plan		
Species	Common Name	Qty (oz)
<i>Bouteloua curtipendula</i>	Side Oats Grama	48.00
<i>Elymus trachycaulus</i>	Slender wheatgrass	24.00
<i>Schizachyrium scoparium</i>	Little bluestem	48.00
<i>Sporobolus heterolepis</i>	Prairie dropseed	8.00
<i>Achillea millefolium</i>	Yarrow	1.50
<i>Allium stellatum</i>	Prairie onion	2.00
<i>Anemone canadensis</i>	Meadow/Canada	1.00
<i>Aquilegia canadensis</i>	Wild columbine	1.00
<i>Artemisia ludoviciana</i>	White sage	1.00
<i>Asclepias verticillata</i>	Whorled milkweed	2.00
<i>Chamaecrista fasciculata</i>	Partridge pea	4.00
<i>Geranium maculatum</i>	Wild geranium	2.00
<i>Pycnanthemum</i>	Virginia mountain mint	1.00
<i>Ratibida columnifera</i>	Upright coneflower	4.00
<i>Rudbeckia hirta</i>	Black-eyed Susan	4.00
<i>Oligoneuron album</i>	Stiff aster (goldenrod)	2.00
<i>Symphotrichum ericoides</i>	Heath aster	0.50
<i>Symphotrichum laeve</i>	Smooth blue aster	2.00
<i>Zizia aurea</i>	Golden alexanders	4.00

Tall Prairie Mix (Open) Grazing Vegetation Management Plan		
Species	Common Name	Qty (oz)
<i>Andropogon gerardii</i>	Big bluestem	16.00
<i>Bouteloua curtipendula</i>	Side Oats Grama	32.00
<i>Elymus canadensis</i>	Canada wild rye	32.00
<i>Elymus trachycaulus</i>	Slender wheatgrass	16.00
<i>Panicum virgatum</i>	Switch grass	4.00
<i>Schizachyrium scoparium</i>	Little bluestem	16.00
<i>Sorghastrum nutans</i>	Indian grass	8.00
<i>Sporobolus heterolepis</i>	Prairie dropseed	4.00
<i>Achillea millefolium</i>	Yarrow	1.00
<i>Allium stellatum</i>	Prairie onion	1.00
<i>Asclepias syriaca</i>	Common milkweed	2.00
<i>Chamaecrista fasciculata</i>	Partridge pea	4.00
<i>Heliopsis helianthoides</i>	False sunflower	4.00
<i>Liatris aspera</i>	Rough blazing star	1.00
<i>Liatris pycnostachya</i>	Prairie blazing star	1.00
<i>Monarda fistulosa</i>	Wild bergamot	0.50
<i>Oligoneuron rigidum</i>	Stiff goldenrod	2.00
<i>Pycnanthemum</i>	Virginia mountain	1.00
<i>Ratibida columnifera</i>	Upright coneflower	4.00
<i>Rudbeckia hirta</i>	Black-eyed Susan	4.00
<i>Solidago speciosa</i>	Showy goldenrod	1.00
<i>Symphotrichum</i>	Heath aster	0.50
<i>Symphotrichum laeve</i>	Smooth blue aster	1.00
<i>Verbena stricta</i>	Hoary vervain	1.00
<i>Zizia aurea</i>	Golden alexanders	3.00

Wet Prairie Mix Grazing Vegetation Management Plan		
Species	Common Name	Qty (oz)
<i>Andropogon gerardii</i>	Big bluestem	40.00
<i>Bromus ciliatus</i>	Fringed brome	8.00
<i>Calamagrostis canadensis</i>	Blue joint grass	1.00
<i>Elymus virginicus</i>	Virginia wild rye	40.00
<i>Glyceria grandis</i>	Reed manna grass	2.00
<i>Glyceria striata</i>	Fowl manna grass	2.00
<i>Panicum virgatum</i>	Switch grass	4.00
<i>Poa palustris</i>	Fowl bluegrass	2.00
<i>Sorghastrum nutans</i>	Indian grass	18.00
<i>Spartina pectinata</i>	Prairie cord grass	4.00
<i>Carex pellita</i>	Broad leaved woolly sedge	1.00
<i>Carex stricta</i>	Common tussock sedge	1.00
<i>Carex vulpinoidea</i>	Fox sedge, Brown fox sedge	4.00
<i>Scirpus atrovirens</i>	Green bulrush	0.50
<i>Scirpus cyperinus</i>	Wool grass	0.50
<i>Anemone canadensis</i>	Meadow/Canada anemone	1.00
<i>Asclepias incarnata</i>	Swamp milkweed	4.00
<i>Doellingeria umbellata</i>	Flat-topped aster	1.50
<i>Eupatorium perfoliatum</i>	Common boneset	2.00
<i>Euthamia graminifolia</i>	Common grass-leaved goldenrod	1.00
<i>Eutrochium maculatus</i>	Spotted Joe Pye weed	2.00
<i>Helenium autumnale</i>	Sneezeweed	1.50
<i>Helianthus grosseserratus</i>	Sawtooth sunflower	4.00
<i>Liatris pycnostachya</i>	Prairie blazing star	1.00
<i>Lobelia siphilitica</i>	Great blue lobelia	0.50
<i>Mimulus ringens</i>	Monkey flower	0.20
<i>Pycnanthemum virginianum</i>	Virginia mountain mint	1.30
<i>Symphotrichum puniceum</i>	Marsh aster	2.00
<i>Verbena hastata</i>	Blue vervain	4.00
<i>Vernonia fasciculata</i>	Common ironweed	2.00
<i>Veronicastrum virginicum</i>	Culver's root	1.00
<i>Zizia aurea</i>	Golden alexanders	3.00

Mowing Vegetation Management
Seed Mixes

Short Prairie Mix (Array)		
Mowing Vegetation Management Plan		
Species	Common Name	Qty (oz)
<i>Bouteloua curtipendula</i>	Side Oats Grama	48.00
<i>Elymus trachycaulus</i>	Slender wheatgrass	24.00
<i>Schizachyrium scoparium</i>	Little bluestem	48.00
<i>Sporobolus heterolepis</i>	Prairie dropseed	8.00
<i>Achillea millefolium</i>	Yarrow	0.50
<i>Allium stellatum</i>	Prairie onion	0.50
<i>Amorpha canescens</i>	Leadplant	0.50
<i>Anemone canadensis</i>	Meadow/Canada	0.50
<i>Aquilegia canadensis</i>	Wild columbine	0.50
<i>Artemisia ludoviciana</i>	White sage	0.50
<i>Asclepias verticillata</i>	Whorled milkweed	1.00
<i>Astragalus canadensis</i>	Canadian milk vetch	4.00
<i>Dalea candida</i>	White prairie clover	3.00
<i>Dalea purpurea</i>	Purple prairie clover	3.00
<i>Desmodium canadense</i>	Showy tick trefoil	4.00
<i>Geranium maculatum</i>	Wild geranium	0.50
<i>Pycnanthemum</i>	Virginia mountain mint	0.50
<i>Ratibida columnifera</i>	Upright coneflower	4.00
<i>Rudbeckia hirta</i>	Black-eyed Susan	4.00
<i>Oligoneuron album</i>	Stiff aster (goldenrod)	0.50
<i>Symphyotrichum ericoides</i>	Heath aster	0.50
<i>Symphyotrichum laeve</i>	Smooth blue aster	1.00
<i>Zizia aurea</i>	Golden alexanders	3.00

Tall Prairie Mix (Open)		
Mowing Vegetation Management Plan		
Species	Common Name	Qty
<i>Andropogon gerardii</i>	Big bluestem	16.00
<i>Bouteloua curtipendula</i>	Side Oats grama	32.00
<i>Elymus canadensis</i>	Canada wild rye	32.00
<i>Elymus trachycaulus</i>	Slender wheatgrass	16.00
<i>Panicum virgatum</i>	Switch grass	4.00
<i>Schizachyrium scoparium</i>	Little bluestem	16.00
<i>Sorghastrum nutans</i>	Indian grass	8.00
<i>Sporobolus heterolepis</i>	Prairie dropseed	4.00
<i>Achillea millefolium</i>	Yarrow	1.00
<i>Allium stellatum</i>	Prairie onion	1.00
<i>Asclepias syriaca</i>	Common milkweed	2.00
<i>Astragalus canadensis</i>	Canadian milk vetch	3.00
<i>Dalea candida</i>	White prairie clover	3.00
<i>Dalea purpurea</i>	Purple prairie clover	3.00
<i>Desmodium canadense</i>	Showy tick trefoil	3.00
<i>Heliopsis helianthoides</i>	False sunflower	3.00
<i>Liatris aspera</i>	Rough blazing star	1.00
<i>Liatris pycnostachya</i>	Prairie blazing star	1.00
<i>Monarda fistulosa</i>	Wild bergamot	0.50
<i>Oligoneuron rigidum</i>	Stiff goldenrod	0.50
<i>Pycnanthemum virginianum</i>	Virginia mountain mint	0.50
<i>Ratibida columnifera</i>	Upright coneflower	3.00
<i>Rudbeckia hirta</i>	Black-eyed Susan	3.00
<i>Solidago speciosa</i>	Showy goldenrod	0.50
<i>Symphotrichum ericoides</i>	Heath aster	0.50
<i>Symphotrichum laeve</i>	Smooth blue aster	0.50
<i>Verbena stricta</i>	Hoary vervain	1.00
<i>Zizia aurea</i>	Golden alexanders	1.00

**Wet Prairie Mix
Mowing Vegetation Management Plan**

Species	Common Name	Qty (oz)
<i>Andropogon gerardii</i>	Big bluestem	40.00
<i>Bromus ciliatus</i>	Fringed brome	8.00
<i>Calamagrostis canadensis</i>	Blue joint grass	1.00
<i>Elymus virginicus</i>	Virginia wild rye	40.00
<i>Glyceria grandis</i>	Reed manna grass	2.00
<i>Glyceria striata</i>	Fowl manna grass	2.00
<i>Panicum virgatum</i>	Switch grass	4.00
<i>Poa palustris</i>	Fowl bluegrass	2.00
<i>Sorghastrum nutans</i>	Indian grass	18.00
<i>Spartina pectinata</i>	Prairie cord grass	4.00
<i>Carex pellita</i>	Broad leaved woolly sedge	1.00
<i>Carex stricta</i>	Common tussock sedge	1.00
<i>Carex vulpinoidea</i>	Fox sedge, Brown fox sedge	4.00
<i>Scirpus atrovirens</i>	Green bulrush	0.50
<i>Scirpus cyperinus</i>	Wool grass	0.50
<i>Anemone canadensis</i>	Meadow/Canada anemone	1.00
<i>Asclepias incarnata</i>	Swamp milkweed	2.00
<i>Desmodium canadense</i>	Showy tick trefoil	4.00
<i>Doellingeria umbellata</i>	Flat-topped aster	1.00
<i>Eupatorium perfoliatum</i>	Common boneset	2.00
<i>Euthamia graminifolia</i>	Common grass-leaved goldenrod	1.00
<i>Eutrochium maculatus</i>	Spotted Joe Pye weed	2.00
<i>Helenium autumnale</i>	Sneezeweed	2.00
<i>Helianthus grosseserratus</i>	Sawtooth sunflower	2.00
<i>Liatris pycnostachya</i>	Prairie blazing star	2.00
<i>Lobelia siphilitica</i>	Great blue lobelia	2.00
<i>Mimulus ringens</i>	Monkey flower	0.50
<i>Pycnanthemum virginianum</i>	Virginia mountain mint	0.50
<i>Symphyotrichum puniceum</i>	Marsh aster	0.50
<i>Verbena hastata</i>	Blue vervain	4.00
<i>Vernonia fasciculata</i>	Common ironweed	1.00
<i>Veronicastrum virginicum</i>	Culver's root	0.50
<i>Zizia aurea</i>	Golden alexanders	4.00

Harmony Solar Project
Appendix H
Harmony Policy Statement



Harmony Solar ND, LLC (Harmony) is committed to the safe and environmentally sound operation of its facilities and to the health and safety of the surrounding community. To these ends, Harmony will:

- Develop and implement an Environmental, Health, and Safety Plan in coordination with local and state emergency management officials;
- Maintain coordination with local units of government during the construction and operation of the facility to avoid and mitigate any conflicts that may occur; and
- Utilize seed mixes that will promote biodiversity, create stable habitat, attract pollinators, and stabilize soils.

Harmony will maintain a philosophy of openness and willingness to partner with landowners and community leaders throughout the development, construction, and operation of the Harmony Solar Project. This openness allows Harmony to identify environmental issues before they become problems.

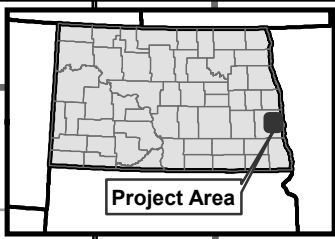

Gunkel Township

Gardner Township

Amenia Township

Rush River Township

Berlin Township

Amenia

Harmony Solar Project

Prosper

18

Lower Branch Rush River

Casselton Township

Harmony Township

Raymond Township

Casselton

Mapleton

Everest Township

Durbin Township

Mapleton Township

94

0 1 2 Miles

1:100,000



Harmony Solar Project