

5410 S 49th W Ave
Tulsa, Oklahoma 74107
P.O. Box 102
Tulsa, Oklahoma 74101-0102
Tel: 1 (918) 582 2186
Fax: 1 (918) 582 5163
Email: info@borninc.com

BORN INC TULSA



March 22, 2017

To Whom It May Concern:

SUBJECT: EMISSIONS FROM BORN HEATERS
BORN REF: XXXX

Please find below *typical* emissions from Born Heaters based on Best Available Combustion Technology (BACT) in the current market.

NOx: 0.030 lb/MMBtu, HHV from Burners w/o SCR System
NOx: 0.0063 lb/MMBtu, HHV w/ SCR System
NH3 slip: 5 ppmv, wet w/ SCR System

CO: 0.028 lb/MMBtu, HHV
Particulates: 0.004 lb/MMBtu, HHV

NOTES:

1. Emissions valid at design and normal operating (80% of design) conditions of burners only and at design excess air.
2. CO and particulates (PM10) emissions valid at firebox temperature higher than 1350 F.
3. Emission values corrected to 3% O₂, dry basis.
4. Particulate emissions are based on those components of solid matter directly generated through incomplete combustion and are exclusive of condensable products of complete combustion, refractory particulate, residual ash, and air-borne matter.
5. Above emissions are valid for clean natural gas firing only. If available fuel is not natural gas, detailed composition is required to analyze and provide emission values.



MERICHEM COMPANY

PRELIMINARY LO-CAT® EFFLUENT COMPOSITION
AY-5254 - VEPICA / DAKOTA REFINERY

REVA
8/3/2016

| 4 MMSCFD - Oxidizer Vent | | 4 MMSCFD - Flash Drum Vent | |
|---------------------------|---------|----------------------------|----------|
| Temperature | 125 | Temperature | 125 |
| Pressure | 0 | Pressure | 10 |
| Mole Fraction Vapor | 100 | Mole Fraction Vapor | 100 |
| Molecular Weight | 27.3 | Molecular Weight | 25.5 |
| Mass Density | 0.057 | Mass Density | 0.095 |
| Molar Flow | 250.2 | Molar Flow | 3.6 |
| Mass Flow | 6831 | Mass Flow | 93 |
| Vapor Volumetric Flow | 119551 | Vapor Volumetric Flow | 979 |
| Std Vapor Volumetric Flow | 2.279 | Std Vapor Volumetric Flow | 0.033 |
| Compressibility | 0.999 | Compressibility | 0.994 |
| Component | Mole % | Component | Mole % |
| H2 | 0.027 | H2 | 10.237 |
| C1 | 0.095 | C1 | 26.821 |
| Ethylene | 0.152 | Ethylene | 13.982 |
| C2 | 0.091 | C2 | 23.610 |
| C3 | 0.080 | C3 | 10.222 |
| iC4 | 0.004 | iC4 | 1.868 |
| nC4 | 0.014 | nC4 | 4.959 |
| H2S | <1 ppmv | H2S | <10 ppmv |
| CO2 | 0 | CO2 | 8.300 |
| H2O | 14.486 | H2O | 16.158 |
| Oxygen | 16.158 | Oxygen | 68.124 |
| N2 | 68.124 | N2 | 0 |
| Ar | 0.810 | Ar | 0 |

| 9.4 MMSCFD - Oxidizer Vent | | 9.4 MMSCFD - Flash Drum Vent | |
|----------------------------|---------|------------------------------|---------|
| Temperature | 125 | Temperature | 125 |
| Pressure | 0 | Pressure | 10 |
| Mole Fraction Vapor | 100 | Mole Fraction Vapor | 100 |
| Molecular Weight | 27.3 | Molecular Weight | 27.3 |
| Mass Density | 0.057 | Mass Density | 0.057 |
| Molar Flow | 589.1 | Molar Flow | 589.1 |
| Mass Flow | 16081 | Mass Flow | 16081 |
| Vapor Volumetric Flow | 281450 | Vapor Volumetric Flow | 281450 |
| Std Vapor Volumetric Flow | 5.365 | Std Vapor Volumetric Flow | 5.365 |
| Compressibility | 0.999 | Compressibility | 0.999 |
| Component | Mole % | Component | Mole % |
| H2 | 0.027 | H2 | 0.027 |
| C1 | 0.094 | C1 | 0.094 |
| Ethylene | 0.160 | Ethylene | 0.160 |
| C2 | 0.090 | C2 | 0.090 |
| C3 | 0.030 | C3 | 0.030 |
| iC4 | 0.003 | iC4 | 0.003 |
| nC4 | 0.014 | nC4 | 0.014 |
| H2S | <1 ppmv | H2S | <1 ppmv |
| CO2 | 0 | CO2 | 0 |
| H2O | 14.487 | H2O | 14.487 |
| Oxygen | 16.161 | Oxygen | 16.161 |
| N2 | 68.124 | N2 | 68.124 |
| Ar | 0.810 | Ar | 0.810 |

| 9.4 MMSCFD - Flash Drum Vent | | 9.4 MMSCFD - Flash Drum Vent | |
|------------------------------|----------|------------------------------|----------|
| Temperature | | Temperature | |
| Pressure | | Pressure | |
| Mole Fraction Vapor | | Mole Fraction Vapor | |
| Molecular Weight | | Molecular Weight | |
| Mass Density | | Mass Density | |
| Molar Flow | | Molar Flow | |
| Mass Flow | | Mass Flow | |
| Vapor Volumetric Flow | | Vapor Volumetric Flow | |
| Std Vapor Volumetric Flow | | Std Vapor Volumetric Flow | |
| Compressibility | | Compressibility | |
| Component | Mole % | Component | Mole % |
| H2 | 10.237 | H2 | 10.237 |
| C1 | 26.821 | C1 | 26.821 |
| Ethylene | 13.982 | Ethylene | 13.982 |
| C2 | 23.610 | C2 | 23.610 |
| C3 | 10.222 | C3 | 10.222 |
| iC4 | 1.868 | iC4 | 1.868 |
| nC4 | 4.959 | nC4 | 4.959 |
| H2S | <10 ppmv | H2S | <10 ppmv |
| CO2 | 0 | CO2 | 0 |
| H2O | 8.301 | H2O | 8.301 |
| Oxygen | 0 | Oxygen | 0 |
| N2 | 0 | N2 | 0 |
| Ar | 0 | Ar | 0 |

Notes:

1. Oxidizer Vent gas will be at 0 psig at Merichem battery limits, boosting pressure for indination is not in Merichem scope.
2. Both Oxidizer Vent and Flash Drum Vent gas are saturated with water and may condense water in downstream piping.
3. Stainless steel piping/ducting is recommended for the Oxidizer Vent Gas outside Merichem battery limits.

THE CONTENT OF THIS DOCUMENT IS SUBJECT TO A CONFIDENTIALITY AGREEMENT, SHALL REMAIN THE PROPERTY OF MERICHEM COMPANY, AND SHALL NOT BE DISCLOSED TO OTHERS, REPRODUCED, OR USED IN ANY WAY OTHER THAN AS PROVIDED BY WRITTEN AGREEMENT WITH MERICHEM COMPANY



Cooling Tower Depot, Inc.
651 Corporate Circle, Suite 206
Golden, CO 80401
Phone (720) 746-1234
Fax: (720) 746-1110
info@coolingtowerdepot.com

Vepica USA

CTD Proposal Number: CTD-7335-14-14

Project: Meridian

Project Location: ND

Cooling Tower Design Conditions and Dimensions:

| | | | |
|-----------------------|--------|----------------------------|------------------|
| Water Flow Rate (gpm) | 12,500 | CTD Model # | CFD-241820-5I-14 |
| Hot Water Temp (F) | 110 | Cell Dimensions (ft) | 24L x 18W x 20H |
| Cold Water Temp (F) | 90 | Tower Dimensions (ft) | 120L x 18W x 20H |
| Wet Bulb Temp (F) | 83 | Fan Power/Cell (HP) | 40 |
| Pump Head Height (ft) | 16.9 | Evaporation/Drift Loss (%) | 1.66% / 0.001% |

Cooling Tower Features:

- 5 cell inline counterflow, induced draft cooling tower
- Structural Material: Douglas Fir
- Hardware material: 300 series SS
- Fill: Heavy Duty, High Performance PVC Film Fill
- Cellular PVC drift eliminators
- Fan Deck Material: 1in DF Plywood
- Partition Material: 8 oz Std 4.2 Corr
- Windwall Material: 8 oz Std 4.2 Corr
- Casing Material: 8 oz Std 4.2 Corr
- FRP or PVC header with PVC lateral distribution system
- Addax composite drive shafts with 316 SS couplings
- Amarillo gear boxes
- SPDT vibration switches
- 14 ft diameter 4 blade high efficiency fans
- 6 ft high FRP fan cylinders
- 40 hp high efficiency, 1 speed motors (480 volt, 3 phase, 60 Hz, 1780 rpm)
- 1 HDG Steel escape ladder
- 1 Douglas Fir stairway
- Louverless design

Material Pricing FOB Shipping Points: **\$266,316.00** (USD)



Estimated hours required for field erection of this cooling tower: 1,601 manhours



Cooling Tower Depot, Inc.
651 Corporate Circle, Suite 206
Golden, CO 80401
Phone (720) 746-1234
Fax: (720) 746-1110
info@coolingtowerdepot.com

Equipment And Work To Be Furnished By Others or Purchased As Options:

- (1) Electrical Power
- (2) Switch Gear and Starters
- (3) Wiring and Controls
- (4) Tower Lighting
- (5) Lightning Protection System
- (6) Fire Protection System
- (7) Circulating Water Systems, including: pump, yard pipe, risers, and valves
- (8) Blow Down System
- (9) Makeup Water Piping
- (10) Basin with Anchor Bolts
- (11) Installation Labor (estimated at 1,601 manhours)
- (12) Freight to Jobsite

Please call customer service at **(877) 243-3945** to request a quote for any required options including your specific project freight and installation requirements, or click [here](#) to request a quote via email.

Proposal Notes:

- (1) Prices do not include sales/use tax and purchaser is responsible for any and all applicable taxes.
- (2) Prices do not include any permits, certificates or special licenses that may be required.
- (3) CTD payment terms: 20% due upon order placement, 20% due upon submittal of customer engineering package (general arrangement drawings, basin drawings and load drawings). Remaining 60% billed upon shipment of materials. All invoices due Net 30 Days from invoice date. Freight and Sales Tax (where applicable) will be billed Pre-Pay and Add.
- (4) CTD standard warranty is 18 months after shipment or 12 months after start-up, whichever occurs first.
- (5) CTD General Terms and Conditions, which are available at <http://www.coolingtowerdepot.com>, are incorporated as part of this document. These terms shall apply unless otherwise agreed upon.
- (6) This proposal is valid for 30 days from the date on which the DEPOT optimization was generated. This proposal expires on Friday, March 31, 2017.

Submitted by,
Cooling Tower Depot, Inc.

A handwritten signature in black ink, appearing to read "Steven D. Adams", with a stylized flourish at the end.

Steven D. Adams
President



Cooling Tower Depot, Inc.
651 Corporate Circle, Suite 206
Golden, CO 80401
Phone (720) 746-1234
Fax: (720) 746-1110
info@coolingtowerdepot.com

General:

| | |
|------------------|--|
| Selection | Heavy Duty Industrial Counterflow |
| Tower Model | CFD-241820-5I-14 |
| Tower Type | 5 cell inline counterflow, induced draft cooling tower |
| Air Inlet Scheme | 2 sides, 2 ends |

Design & Operating Conditions:

| | |
|--|--------------|
| Circulating Water Flow, U.S. gpm | 12,500 |
| Hot (inlet) Water Temp., deg F | 110 |
| Cold (outlet) Water Temp., deg F | 90 |
| Wet Bulb Temp., deg F Inlet | 83 |
| Tower Pump Head, ft. | 16.9 |
| Motor H.P. (Driver Output) | 40 |
| Drift Loss, % of circulating flow | 0.001 |
| Evaporation Loss (at design), % circ. flow | 1.66 |
| Design Wind Load, lbs./sq. ft. | 30 |
| Design Seismic Load | Zone 2 |
| Tower Site (ground level, roof, etc.) | Ground Level |
| Elevation Above Sea Level, ft. | 100 |
| Tower Exposure | Unobstructed |

Structural Details:

| | |
|--------------------------------------|---|
| Number of Cells | 5 |
| Fans Per Cell | 1 |
| Total Number of Fans | 5 |
| Nominal Cell Dimensions, L x W, ft. | 24 x 18 |
| Overall Tower Dimensions, L x W, ft. | 120 x 18 |
| Height - Basin Curb to Fan Deck, ft. | 20 |
| Fan Stack Height, ft. | 6 |
| Overall Tower Height, ft. | 26 |
| Inside Basin Dimensions, L x W, ft. | 126 x 24 |
| Column Extensions, Perimeter, ft. | 1 |
| (below basin curb) Interior, ft. | 4 |
| Anchorage | Perimeter |
| Hot Water Inlet - Number | 5 |
| Nominal Diameter, in. | 12 |
| Inlet Water Flange | STD ANSI 125lb flange, 1' outside tower |
| Height Inlet Above Basin Curb, ft. | 12 |



Cooling Tower Depot, Inc.
651 Corporate Circle, Suite 206
Golden, CO 80401
Phone (720) 746-1234
Fax: (720) 746-1110
info@coolingtowerdepot.com

Structural Details (Continued):

| | |
|------------------------|--|
| Access to Top of Tower | 1 HDG Steel ladder, 1 Douglas Fir stairway |
| Shipping Weight, lbs. | 98,893 |
| Operating Weight, lbs. | 149,304 |

Materials Of Construction:

| | |
|------------------------------|--------------------------------------|
| Framework Members | Douglas Fir |
| Casing | 8 oz Std 4.2 Corr |
| Fill Media | 10 Mil PVC Film Pack Fill |
| Fill Support | Douglas Fir |
| Drift Eliminators | 15 Mil Cellular PVC |
| Spacer | PVC |
| Fan Stacks | Fiberglass |
| Louver Material | N/A |
| Partitions | 8 oz Std 4.2 Corr |
| Fan Deck | 1in DF Plywood |
| Water Distribution Type | Low Pressure Downspray |
| Materials | PVC/FRP Header, PVC Laterals |
| Lumber Pre-Treatment | Pressure |
| Type of Treatment | CCA/ACC |
| Items Treated | All Lumber |
| Splashers or Spray Nozzles | Polypropylene |
| Stairway and Handrail | Douglas Fir |
| Structural Connectors | 300 series SS |
| Ring Joint Connectors | 300 series SS |
| Bolts, Nuts, Washers | 300 series SS |
| Anchor Connectors | 300 series SS |
| Nails | 300 series SS |
| Mechanical Equipment Support | Unitized Hot Dipped Galvanized Steel |
| Anchor Bolts Material | By Owner |
| Furnished by | Other |
| Cold Water Basin Material | Concrete |
| Furnished by | Other |
| Basin Accessories, by Mfg. | None |

Fans:

| | |
|---------------|-----------|
| Number | 5 |
| Type or Model | APT-14H-4 |
| Manufacturer | Hudson |
| Diameter, ft | 14 |



Cooling Tower Depot, Inc.
651 Corporate Circle, Suite 206
Golden, CO 80401
Phone (720) 746-1234
Fax: (720) 746-1110
info@coolingtowerdepot.com

Fans (Continued):

| | |
|-----------------------------------|-----------------------------------|
| Number of Blades | 4 |
| Fan Speed, rpm | 271.3 |
| Fan Tip Speed, ft./min. | 11,934.2 |
| Fan HP | 40 |
| Blade Material | Fiberglass Reinforced Vinyl Ester |
| Hub Material | Epoxy Coated |
| Total Static Pressure, inches H2O | 0.554 |
| Velocity Pressure, inches H2O | 0.169 |
| Air Delivery per Fan, ACFM | 252,766 |
| Fan Static Efficiency | 64.4 |
| Fan Total Efficiency | 84.0 |

Speed Reducer

| | |
|----------------------------|---------------------------|
| Number | 5 |
| Type | Right Angle, Spiral Bevel |
| Model | 135 |
| Manufacturer | Amarillo |
| Reduction Ratio | 6.56 : 1 |
| Service Factor at Rated HP | 3.0 |
| Number of Reductions | 2 |

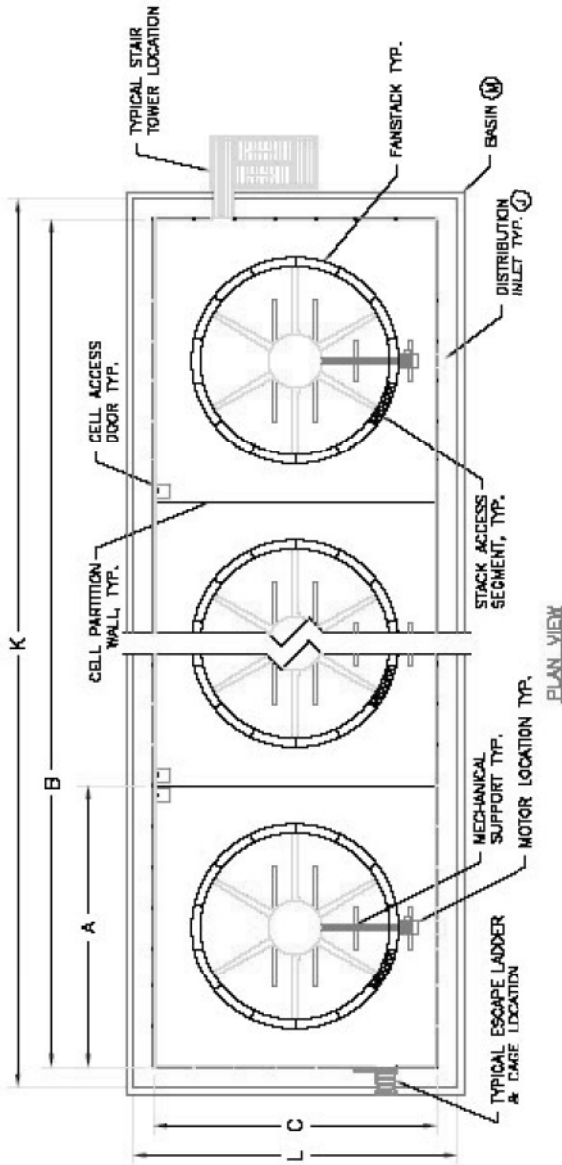
Drive Shaft

| | |
|----------------------|------------------------------|
| Number | 5 |
| Type | Full Floating Non-Lubricated |
| Model | LRH450.270 |
| Manufacturer | Addax |
| Service Factor | 5.1 |
| Drive Shaft Material | Composite |
| Coupling Material | 316 SS |

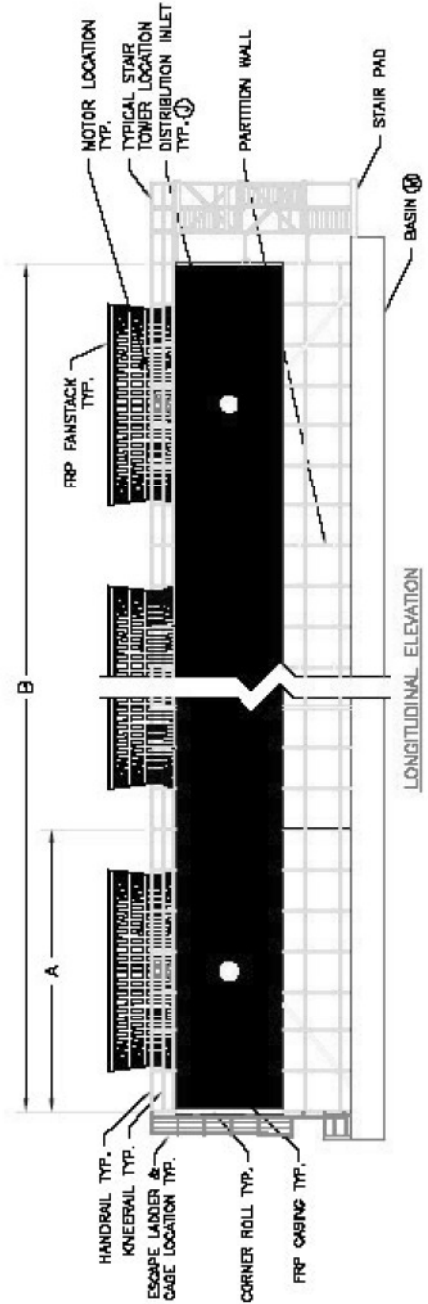
Motor

| | |
|--------------------------|------------------------------------|
| Number | 5 |
| Kind | Electric Motor |
| Type | Totally Enclosed Fan Cooled (TEFC) |
| Manufacturer | Baldor, Toshiba, US Motor or Equal |
| Full Load Speed, RPM | 1800 |
| Electric Characteristics | 3 phase, 60hZ, 460 volts |
| Rated HP | 40 |

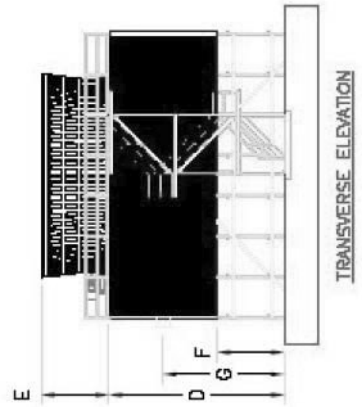
| Model No: CFD-241820-5I-14 | |
|-------------------------------|--------------------------|
| Tower Dimensional Information | |
| A | Cell Length 24' |
| B | Tower Length 120' |
| C | Cell Width 18' |
| D | Tower Height 20' |
| E | Stack Height 6' |
| F | Air Inlet Height 5' |
| G | Dist. Inlet Height 12" |
| H | Dist. Extension 12" |
| J | Dist. Inlet Diameter 12" |
| K | Basin Length 126' |
| L | Basin Width 24' |
| M | Basin Depth 4' |



PLAN VIEW



LONGITUDINAL ELEVATION





TRANSVERSE ELEVATION

COOLING TOWER DEPOT, INC.

| | | | |
|------------------------------------|--------|-----------------------------|------------|
| Drawing Name: GENERAL ARRANGEMENTS | | Proposal No: CTD-7335-14-14 | |
| Customer Name: Vepica USA | | Project Name: | |
| Scale: NOT TO SCALE | Rev: A | Date: 03/01/2017 | Notes: N/A |

Exhibit C: Controls Technology Review

| | | | |
|--|--|---|---|
|  | Control Technology Review | VEPICA CODE: P-5715043-01-001-18035-I001 |  |
| | | COMPANY CODE: TBD | |
| | | ISSUE: 1 DATE: 03/29/17 | |
| | | SHEET: 1 OF 24 | |

| | |
|---|----------------------|
| VEPICA CODE : P-5715043-01-001-18035-I001 | SHEET 1 OF 24 |
| COMPANY CODE: TBD | |
| TITLE: EMISSIONS INVENTORY – CONTROL TECHNOLOGY REVIEW | |



PROJECT N°: P-5715043

NAME: PERMITTING SUPPORT – DAVIS REFINERY

CLIENT: MERIDIAN ENERGY GROUP INC.



LOCATION: BILLINGS COUNTY, NORTH DAKOTA

| | | | | | | |
|--------------|-------------|---------------------------|--------------------------------|-----------------|------------------------|------------------------|
| | | | | | | |
| | | | | | | |
| | | | | | | |
| | | | | | | |
| | | | | | | |
| | | | | | | |
| | | | | | | |
| | | | | | | |
| 1 | 3/29/17 | ISSUED FOR PTC AMMENDMENT | E. MARTINEZ (Zia) J. SOLANO | A. PENA-ISEA | C. GARCÍA | T. JOHNSON |
| 0 | 9/21/16 | ISSUED FOR PTC | E. MARTINEZ (Zia) J. SOLANO | A. PENA-ISEA | C. GARCÍA | T. JOHNSON |
| ISSUE | DATE | DESCRIPTION | PREPARED | REVIEWED | APPROVED VEPICA | APPROVED CLIENT |

| | | | |
|---|---|---|---|
|  | CONTROLS TECHNOLOGY REVIEW | VEPICA CODE: P-5715043-01-001-18035-I001 |  |
| | | COMPANY CODE: TBD | |
| | | ISSUE: 1 DATE: 03/29/17 | |
| | | SHEET: 2 OF 24 | |

INDEX

| <u>DESCRIPTION</u> | <u>SHEET</u> |
|--|---------------------|
| 1. INTRODUCTION | 3 |
| 1.1. Document Scope | 3 |
| 1.2. Methodology | 4 |
| 2. SUMMARY OF CONTROLLED AND UNCONTROLLED EMISSIONS | 5 |
| 3. IDENTIFICATION OF APPLICABLE CONTROL TECHNOLOGIES | 9 |
| 3.1. Summary of Proposed Controls | 22 |
| 4. REFERENCES | 23 |

| | | | |
|---|---|---|---|
|  | CONTROLS TECHNOLOGY REVIEW | VEPICA CODE: P-5715043-01-001-18035-I001 |  |
| | | COMPANY CODE: TBD | |
| | | ISSUE: 1 DATE: 03/29/17 | |
| | | SHEET: 3 OF 24 | |

1. INTRODUCTION

Meridian Energy Group (MEG) has engaged VEPICA to develop an air permit application for construction of the 55,000 BPD (barrels per day) oil Davis Refinery in Billings County, North Dakota. The initial Permit to Construct (PTC) application was submitted to NDDoH on October 17th, 2016, based on Rev.0 of this document which reflected a cracking refinery configuration with a Fluid Catalytic Cracking (FCC) and downstream units for conversion of atmospheric bottoms into higher value products. After submittal of the initial PTC application, and upon further evaluation by Meridian of the market conditions and off taker agreements for the Davis Refinery products, in which production of jet and diesel fuel will be important, the hydrocracking (HYK) refining process was chosen as an attractive alternative to FCC. This revision of the Control Technology Review provides a descriptive analysis of the most technologically feasible air pollution control equipment to be considered in the design of the emission units and equipment for the HYK process configuration of the proposed Davis Refinery.



Based on the estimated emissions for the facility, the source qualifies as a synthetic minor source under North Dakota Air Quality regulations. As such, formal Best Available Control Technology (BACT) analysis is not applicable for the permitting of the facility. However, this Controls Technology Review generally follows BACT methods for identification of proposed controls. It should be noted that control requirements for a large portion of the air emissions sources for the Davis Refinery plant are specified by EPA regulation under New Source Performance Standards (NSPS), applicable Maximum Achievable Control Technology (MACT) and National Emission Standards for Hazardous Air Pollutants (NESHAP) regulations and/or other applicable regulations.

Final emissions control technologies, control efficiencies, and emissions limits will be specified in permit issued by NDDoH for the Davis Refinery. Upon commencement of operation, Meridian will be required to show compliance with these specified limits and controls and will implement required sampling and reporting to show compliance with permit limits.

1.1. Document Scope

This Control Technologies Review includes a descriptive analysis of the most technologically feasible air pollution control equipment to be considered in the design of Davis Refinery. The determination of which specific technology qualifies and is finally selected as the applicable control to implement is made on a case-by-case basis for each pollutant for each emission unit.

Control selection to be implemented in the facilities design was made under the premise of its technical feasibility and the level of control that can reasonably be expected to be achieved in order to maintain emissions levels of the proposed Davis Refinery at synthetic minor source status. Since formal BACT analysis is not required, analysis for energy, environment and economic impacts was not conducted for proposed emission controls.

| | | | |
|---|---|---|---|
|  | CONTROLS TECHNOLOGY REVIEW | VEPICA CODE: P-5715043-01-001-18035-I001 |  |
| | | COMPANY CODE: TBD | |
| | | ISSUE: 1 DATE: 03/29/17 | |
| | | SHEET: 4 OF 24 | |

1.2. Methodology



While BACT analysis is not specifically required for the proposed Davis Refinery since it qualifies as a minor synthetic source, the methods used for emissions control technology selection have generally followed a BACT analysis approach.

EPA's 1990 Draft Edition of the New Source Review Workshop Manual (NSR Manual) sets forth a standardized procedure for determining BACT. This is the method used by most permitting agencies in the U.S. for compliance analysis. This method is considered to be a "top-down" approach and consists of the following five steps:

1. Identify all control technologies
2. Eliminate technically infeasible options
3. Rank remaining control technologies by control effectiveness
4. Evaluate most effective controls and document results
5. Select BACT

BACT is based primarily on control effectiveness. If a technology providing lesser control is to be utilized, it must be demonstrated that, based on energy, environmental and economic impacts and other costs, it is the best choice.

As previously noted, since formal BACT analysis is not required due to the facility qualifying as a synthetic minor source, analysis for technical feasibility was only cursorily conducted by review of the U.S. EPA RACT/MACT/LAER Clearinghouse database as well as applicable permits from other facilities. In addition, coordination with equipment vendors and suppliers was undertaken for many of the emissions units to obtain project and emissions unit specific guarantees for proposed emissions rates. Analysis of energy, environment and economic impacts was not conducted for the proposed controls since in essentially all instances, the higher level of control available was the one selected.

| | | | |
|---|---|---|---|
|  | CONTROLS TECHNOLOGY REVIEW | VEPICA CODE: P-5715043-01-001-18035-I001 |  |
| | | COMPANY CODE: TBD | |
| | | ISSUE: 1 DATE: 03/29/17 | |
| | | SHEET: 5 OF 24 | |

2. SUMMARY OF CONTROLLED AND UNCONTROLLED EMISSIONS

The inventory of emissions for the identified routine (non-emergency) emissions sources for the proposed Davis Refinery for both, the base case (uncontrolled) and post controls (controlled), are summarized in Tables 1 and 2, respectively for the Primary Operating Scenario (full project build-out) and the controlled emissions for the Alternative Operating Scenario are shown in Table 3. Controlled emission detailed calculations are included in the Emissions Inventory (Exhibit B) of the permit application amendment. Also included in Exhibit B are copies of related manufacturer commitments and guarantees for various process equipment as applicable.



| | | | | | |
|---|-----------------------------------|----------------|--|--|---|
|  | CONTROLS TECHNOLOGY REVIEW | | VEPICA CODE: P-5715043-01-001-18035-I001 | |  |
| | | | COMPANY CODE: TBD | | |
| | ISSUE: 1 | DATE: 03/29/17 | | | |
| | SHEET: 6 | OF 24 | | | |

Table 1. Davis Refinery Summary of Uncontrolled Emissions

| Emission Units | Criteria Pollutants | | | | | | | | | | HAPs | |
|-------------------------------|---------------------|-----------------|--------------|-------------------|--------------|--------------------|----------------|---------------------------|-----------------|-----------------|--------------|--|
| | CO | RP | PM<10 | Filterable PM <10 | PM <2.5 | Filterable PM <2.5 | Condensable PM | NOx (as NO ₂) | SO ₂ | VOC | Total HAPs | |
| Leaks | 0.00 | 0.00 | 0.00 | 0.00 | 0.00 | 0.00 | 0.00 | 0.00 | 0.00 | 195.29 | 29.26 | |
| Tanks | 0.00 | 0.00 | 0.00 | 0.00 | 0.00 | 0.00 | 0.00 | 0.00 | 0.00 | 7.43 | 14.95 | |
| Stationary Combustion Sources | 76.16 | 1.33E-03 | 10.88 | 2.72 | 10.88 | 2.72 | 8.16 | 81.60 | 1.60 | 14.67 | 5.34 | |
| Catalytic Reforming Unit | 0.00 | 0.00 | 0.00 | 0.00 | 0.00 | 0.00 | 0.00 | 0.00 | 0.00 | 0.71 | 0.07 | |
| Sulfur Recovery Plant | 2.36 | 0.00 | 0.00 | 0.00 | 0.00 | 0.00 | 0.00 | 0.52 | 0.22 | 1.65 | 0.00 | |
| Vacuum Systems | 0.00 | 0.00 | 0.00 | 0.00 | 0.00 | 0.00 | 0.00 | 0.00 | 0.00 | 3,679.20 | 0.00 | |
| Blowdown System | 0.83 | 0.00 | 0.01 | 0.01 | 0.01 | 0.01 | 0.00 | 3.66 | 5.20 | 0.15 | 0.00 | |
| Flares | 0.25 | 4.38E-06 | 0.04 | 0.01 | 0.04 | 0.01 | 0.03 | 0.27 | 0.005 | 0.05 | 0.00 | |
| Wastewater | 0.00 | 0.00 | 0.00 | 0.00 | 0.00 | 0.00 | 0.00 | 0.00 | 0.00 | 290.73 | 32.17 | |
| Cooling Towers | 0.00 | 0.00 | 82.78 | 0.00 | 0.00 | 0.00 | 0.00 | 0.00 | 0.00 | 15.77 | 0.00 | |
| Truck Product Loading | 0.00 | 0.00 | 0.00 | 0.00 | 0.00 | 0.00 | 0.00 | 0.00 | 0.00 | 826.96 | 0.00 | |
| Fugitive Dust | 0.00 | 0.00 | 0.00 | 0.00 | 0.00 | 0.00 | 0.00 | 0.00 | 0.00 | 0.00 | 0.00 | |
| Total STPY | 79.60 | 1.34E-03 | 93.71 | 2.73 | 10.92 | 2.73 | 8.19 | 86.04 | 7.02 | 5,032.62 | 81.78 | |

Taken from Exhibit B- EMISSIONS INVENTORY FOR DAVIS REFINERY. VEPICA, 2016. Doc. N° P-5715043-01-001-18042-I001.



| | | | | | |
|---|-----------------------------------|----------------|--|--|---|
|  | CONTROLS TECHNOLOGY REVIEW | | VEPICA CODE: P-5715043-01-001-18035-1001 | |  |
| | | | COMPANY CODE: TBD | | |
| | ISSUE: 1 | DATE: 03/29/17 | | | |
| | SHEET: 7 | OF 24 | | | |

Table 2: Davis Refinery Summary of Controlled Emissions – Primary Operating Scenario

| Emission Units | Criteria Pollutants | | | | | | | | | | HAPs | |
|-------------------------------|---------------------|-----------------|-------------------|--------------|--------------------|----------------|---------------------------------------|-----------------|--------------|--------------|------|--|
| | CO | PM<10 | Filterable PM <10 | PM <2.5 | Filterable PM <2.5 | Condensable PM | NO _x (as NO ₂) | SO ₂ | VOC | Total HAPs | | |
| Leaks | 0.00 | 0.00 | 0.00 | 0.00 | 0.00 | 0.00 | 0.00 | 0.00 | 16.70 | 1.51 | | |
| Tanks | 0.00 | 0.00 | 0.00 | 0.00 | 0.00 | 0.00 | 0.00 | 0.00 | 7.43 | 8.55 | | |
| Stationary Combustion Sources | 76.16 | 1.33E-03 | 2.72 | 10.88 | 2.72 | 8.16 | 34.51 | 1.60 | 14.67 | 1.35 | | |
| Catalytic Reforming Unit | 0.00 | 0.00 | 0.00 | 0.00 | 0.00 | 0.00 | 0.00 | 0.00 | 0.71 | 0.07 | | |
| Sulfur Recovery Plant | 2.36 | 0.00 | 0.00 | 0.00 | 0.00 | 0.00 | 0.52 | 0.22 | 1.65 | 0.00 | | |
| Vacuum Systems | 0.00 | 0.00 | 0.00 | 0.00 | 0.00 | 0.00 | 0.00 | 0.00 | 0.00 | 0.00 | | |
| Blowdown System | 0.83 | 0.00 | 0.01 | 0.01 | 0.01 | 0.00 | 3.66 | 5.20 | 0.15 | 0.00 | | |
| Flares | 0.25 | 4.38E-06 | 0.01 | 0.04 | 0.01 | 0.03 | 0.27 | 0.005 | 0.05 | 0.00 | | |
| Wastewater | 0.00 | 0.00 | 0.00 | 0.00 | 0.00 | 0.00 | 0.00 | 0.00 | 14.54 | 0.72 | | |
| Cooling Towers | 0.00 | 0.00 | 2.07 | 0.00 | 0.00 | 0.00 | 0.00 | 0.00 | 0.39 | 0.00 | | |
| Truck Product Loading | 0.00 | 0.00 | 0.00 | 0.00 | 0.00 | 0.00 | 0.00 | 0.00 | 5.34 | 0.00 | | |
| Fugitive Dust | 0.00 | 0.00 | 0.00 | 9.72E-04 | 0.00 | 0.00 | 0.00 | 0.00 | 0.00 | 0.00 | | |
| Total STPY | 79.60 | 1.34E-03 | 2.73 | 10.92 | 2.73 | 8.19 | 38.95 | 7.02 | 61.63 | 12.21 | | |

Taken from Exhibit B- EMISSIONS INVENTORY FOR DAVIS REFINERY. VEPICA, 2016. Doc. N° P-5715043-01-001-18042-1001.





| | | | | | | |
|---|-----------------------------------|--|--|----------------|---|----|
|  | CONTROLS TECHNOLOGY REVIEW | | VEPICA CODE: P-5715043-01-001-18035-1001 | |  | |
| | | | COMPANY CODE: TBD | | | |
| | | | ISSUE: 1 | DATE: 03/29/17 | | |
| | | | SHEET: 8 | OF | | 24 |

Table 3: Davis Refinery Summary of Controlled Emissions – Alternative Operating Scenario, Phase 1

| Emission Units | Criteria Pollutants | | | | | | | | | | HAPs | |
|-------------------------------|---------------------|------------------|-------------------|-------------|--------------------|----------------|---------------------------------------|-----------------|--------------|--------------|------|--|
| | CO | PM ₁₀ | Filterable PM <10 | PM <2.5 | Filterable PM <2.5 | Condensable PM | NO _x (as NO ₂) | SO ₂ | VOC | Total HAPs | | |
| Leaks | 0.00 | 0.00 | 0.00 | 0.00 | 0.00 | 0.00 | 0.00 | 0.00 | 10.27 | 1.20 | | |
| Tanks | 0.00 | 0.00 | 0.00 | 0.00 | 0.00 | 0.00 | 0.00 | 0.00 | 6.66 | 8.55 | | |
| Stationary Combustion Sources | 25.34 | 3.86E-04 | 0.79 | 3.15 | 0.79 | 2.37 | 10.89 | 0.46 | 4.25 | 0.39 | | |
| Catalytic Reforming Unit | 0.00 | 0.00 | 0.00 | 0.00 | 0.00 | 0.00 | 0.00 | 0.00 | 0.06 | 0.01 | | |
| Sulfur Recovery Plant | 0.42 | 0.00 | 0.00 | 0.00 | 0.00 | 0.00 | 0.09 | 0.04 | 0.29 | 0.00 | | |
| Vacuum Systems | 0.00 | 0.00 | 0.00 | 0.00 | 0.00 | 0.00 | 0.00 | 0.00 | 0.00 | 0.00 | | |
| Blowdown System | 0.41 | 0.00 | 0.00 | 0.00 | 0.00 | 0.00 | 1.83 | 2.60 | 0.08 | 0.00 | | |
| Flares | 0.29 | 3.72E-06 | 0.01 | 0.03 | 0.01 | 0.02 | 0.23 | 0.004 | 0.04 | 0.00 | | |
| Wastewater | 0.00 | 0.00 | 0.00 | 0.00 | 0.00 | 0.00 | 0.00 | 0.00 | 9.62 | 0.48 | | |
| Cooling Towers | 0.00 | 0.00 | 0.00 | 0.00 | 0.00 | 0.00 | 0.00 | 0.00 | 0.10 | 0.00 | | |
| Truck Product Loading | 0.00 | 0.00 | 0.00 | 0.00 | 0.00 | 0.00 | 0.00 | 0.00 | 5.34 | 0.00 | | |
| Fugitive Dust | 0.00 | 0.00 | 0.00 | 9.72E-04 | 0.00 | 0.00 | 0.00 | 0.00 | 0.00 | 0.00 | | |
| Total STPY | 26.46 | 3.90E-04 | 0.80 | 3.19 | 0.80 | 2.39 | 13.04 | 3.11 | 36.71 | 10.62 | | |

Taken from Exhibit B- EMISSIONS INVENTORY FOR DAVIS REFINERY. VEPICA, 2017. Doc. N° P-5715043-01-001-18042-1001.

| | | | |
|---|---|---|---|
|  | CONTROLS TECHNOLOGY REVIEW | VEPICA CODE: P-5715043-01-001-18035-I001 |  |
| | | COMPANY CODE: TBD | |
| | | ISSUE: 1 DATE: 03/29/17 | |
| | | SHEET: 9 OF 24 | |

3. IDENTIFICATION OF APPLICABLE CONTROL TECHNOLOGIES

Analysis of technical feasibility was generally conducted by review of the U.S. EPA RACT/BACT/LAER Clearing House Databases, EPA guidance documents and general industry literature for each applicable pollutant source. In addition, coordination with equipment vendors and suppliers was undertaken for many of the emissions units to obtain project and emissions unit specific guidance on control implementation as well as guarantees for proposed emissions rates. Based on this review, identification of technically feasible controls and related typical emissions levels was identified. Literature sources are identified by note and references are included in Section 5 of this document

A list of feasible control technologies considered for implementation for each source category and for each applicable pollutant is presented in Tables 4a-4k. Where proposed controls can address multiple pollutants, discussion has been combined to reduce repetitiveness.



| | | | | | |
|---|-----------------------------------|----------------|--|--|---|
|  | CONTROLS TECHNOLOGY REVIEW | | VEPICA CODE: P-5715043-01-001-18035-1001 | |  |
| | | | COMPANY CODE: TBD | | |
| | ISSUE: 1 | DATE: 03/29/17 | | | |
| | SHEET: 10 | OF 24 | | | |

Table 4a: Davis Refinery – Summary of Air Pollution Control Technology Analysis by Source Category Leaks (Fugitive Emissions)

| Technically Feasible Control Options | Identified Control Efficiency Ranges | Identified Emissions Ranges | Control Efficiency Used | Controlled Emission Factor Used |
|--|--|--|---|---|
| VOC's | | | | |
| Applicable Feasible Technologies | | | | |
| 1.0 Gas collection manifold systems (vapor recovery). 2.0 Enhanced valve packing. 3.0 Low threshold on leak detection and repair detection down to 500 ppm. 4.0 LDAR (Leak, Detection and Repair) program with differential light absorption and ranging (DIAL) or optical gas imaging (OGI) technology. | 1.0 95% ^{1a} 2.0 Inherent in process design 3.0 Inherent in LDAR system design 4.0 97% (valves), 85% pumps, 97% flanges, 97% open ended lines & sample points, (30% heavies) ^{1b, 1e} | Selected Technologies – vapor recovery w/ enhanced LDAR (DIAL & OGI) initiated at 500 ppm detection Specified by MACT and 40 CFR 63 Subpart CC, 40 CFR 60 Subpart GGG ^{1c, 1d} | 97% (valves), 85% pumps, 97% flanges, 97% open ended lines & sample points, (30% heavies) ^{1b} | 500 ppm ^{1d} (per MACT std) |
| ^{1a} EPA Notification, [G.S.R. 186(E), dt. 18th March, 2008] ^{1b} TCEQ – Control Efficiencies for TCEQ Leak Detection and Repair Programs Revised 07/11 (APDG 6129v2) ^{1c} RACT/BACT/LAER Clearinghouse for Petroleum Refining Equipment Fugitive Leaks ^{1d} 40 CFR 63, Subpart CC & 40 CFR 60, Subpart GGG ^{1e} EPA, Leak Detection and Repair – A Best Practices Guide, EPA-305-D-07-001 October 2007 | | | | |

The controls condition for addressing leaks across the refinery is structured around an aggressive LDAR program. In addition, the base condition for this project is that this is a new facility and thus piping and systems are designed to minimize potential for leaks, packing is new, as well as to allow for easy monitoring through LDAR. In addition sample ports are designed into the systems to eliminate open ended lines. Based on EPA Guidance Document, Leak Detection and Repair – A Best Practices Guide (2007), average control effectiveness of a well implemented LDAR program is over 80% across all areas of the plant with the majority of the plant exceeding 90% control efficiencies for VOC reductions. As shown in the calculation of the facility emissions, the average control efficiency across all areas of the plant that we are proposing is approximately 73% (see Emissions Inventory, Exhibit B). LDAR program will utilize optical sensors which will identify leaks well below 100 ppm, will be confirmed by Method 21 test immediately upon identification by optical meter and will require immediate repair. Optical sensing as well as repair when required will be ongoing and continuous throughout the plant.



| | | | | |
|---|---|--|----------------|---|
|  | CONTROLS TECHNOLOGY REVIEW | VEPICA CODE: P-5715043-01-001-18035-1001 | |  |
| | | COMPANY CODE: TBD | | |
| | | ISSUE: 1 | DATE: 03/29/17 | |
| | | SHEET: 11 | OF 24 | |

Table 4b: Davis Refinery – Summary of Applicable Air Pollution Control Technologies by Source Category
Tanks

| Technically Feasible Control Options | Identified Control Efficiency Ranges | Identified Emissions Ranges | Control Efficiency Used | Controlled Emission Factor Used |
|--|---|-------------------------------------|-------------------------|---|
| VOC's / HAPs | | | | |
| Applicable Feasible Technologies | | | | |
| Double Seal and Wipers (part of NESHAP std) | 95 - 98% ^{la, lb} | Limits specified by NESHAP and RACT | 95% ^{la} | Calculated using EPA TANKS for each tank unit |
| la Control Techniques Guidelines for the Oil and Natural Gas Industry (Draft, 2015) lb 40 CFR 63, Subpart CC & 40 CFR 60, Subpart GGG | Selected Technologies – Double seal and wipers (NESHAP std) | | | |

Control requirements and control effectiveness for tanks are specified by 40 CFR Part 60 NSPS as well as by 40 CFR Part 61 and 63 (NESHAP). Also since refined materials stored in fixed roof tanks generally consist of “heavy” products, resulting vapor emissions are minimal.





| | | |
|---|-----------------------------------|--|
|  | CONTROLS TECHNOLOGY REVIEW | VEPICA CODE: P-5715043-01-001-18035-1001 <hr/> COMPANY CODE: TBD <hr/> ISSUE: 1 DATE: 03/29/17 <hr/> SHEET: 12 OF 24 |
| | |  |

Table 4c: Davis Refinery – Summary of Applicable Air Pollution Control Technologies by Source Category Stationary Sources (Process Heaters and Boilers)

| Technically Feasible Control Options | Identified Control Efficiency Ranges | Identified Emissions Ranges | Control Efficiency Used | Controlled Emission Factor Used |
|---|--------------------------------------|---|-------------------------|---------------------------------|
| CO | | | | |
| Applicable Feasible Technologies | | | | |
| 1.0 Regenerative Thermal Or Catalytic Oxidation | 1.0 75 – 95% ^{la} | 1.0 0.008 lb/MMbtu | | |
| 2.0 Low NOx Burner | 2.0 25 - 75% ^{la} | 2.0 0.04 lb/MMbtu | NA | 0.028 lb/MMbtu |
| 3.0 Good Combustion Practices | 3.0 Base Case | 3.0 0.08 lb/MMbtu | | |
| 4.0 Good Combustion Practices with Low NOx Burner | 4.0 96 – 99% ^{lb, c} | 4.0 0.02 – 0.06 lb/MMbtu | | |
| ^{la} Control Techniques Guidelines for the Oil and Natural Gas Industry (Draft, 2015) ^{lb} RACT/BACT/LAER Clearinghouse for Natural Gas Combustion ^{lc} The Costs and Benefits of Selective Catalytic Reduction on Cement Kilns for Multi-Pollutant Control (A. Armendariz, 2008) | | | | |
| NOx | | | | |
| Applicable Feasible Technologies | | | | |
| 1.0 SCR w Low NOx Burners | 1.0 70 – 90% ^{la} | 1.0 0.012 – 0.03 lb/MMbtu ^{lc} | | 1.0 0.0063 lb/MMbtu |
| 2.0 Low NOx Burners | 2.0 70 – 90% ^{la} | 2.0 0.03 – 0.04 lb/MMbtu | 79% ^{ld} | 2.0 0.03 lb/MMBTU |
| 3.0 SCR's | 3.0 70 – 90% ^{la} | 3.0 0.02 – 0.03 lb/MMbtu | | |
| 4.0 SNCR's | 4.0 30 – 50% ^{la} | 4.0 0.04 – 0.09 lb/MMbtu | | |
| ^{la} Control Techniques Guidelines for the Oil and Natural Gas Industry (Draft, 2015) ^{lb} RACT/BACT/LAER Clearinghouse for Natural Gas Combustion, Heaters less than 250 MMBtu/hr ^{lc} RACT/BACT/LAER Clearinghouse & Permit for Northern Plains Grandforks Plant, Primary Reformer (2015) ^{ld} Control effectiveness and emissions levels specified by vendor/supplier guarantee – see Exhibit B | | | | |
| VOCs | | | | |
| Applicable Feasible Technologies | | | | |
| Good Combustion Practices with SCR | 50 – 75% ^{la, c} | 0.005 – 0.014 lb/MMbtu ^{lb} | 75% | 0.0054 lb/MMbtu |
| ^{la} Control Techniques Guidelines for the Oil and Natural Gas Industry (Draft, 2015) ^{lb} RACT/BACT/LAER Clearinghouse & Permit for Valero Refinery, New Orleans, LA, Hydrogen Plant, SMR Heaters (2009) ^{lc} The Costs and Benefits of SCR on Cement Kilns for Multi-Pollutant Control (A. Armendariz, 2008) (HAP destruction = VOC destruction) | | | | |

| | | |
|---|-----------------------------------|---|
|  | CONTROLS TECHNOLOGY REVIEW | VEPICA CODE: P-5715043-01-001-18035-1001 COMPANY CODE: TBD ISSUE: 1 DATE: 03/29/17 SHEET: 13 OF 24 |
| | |  |

| Technically Feasible Control Options | Identified Control Efficiency Ranges | Identified Emissions Ranges | Control Efficiency Used | Controlled Emission Factor Used |
|---|--------------------------------------|----------------------------------|-------------------------|----------------------------------|
| PMS | | | | |
| Applicable Feasible Technologies | | | | |
| 1.0 Good Combustion Practices | 1.0 NA | 1.0 0.004 lb/MMbtu ^{la} | 1.0 NA | 1.0 0.004 lb/MMbtu ^{la} |
| 2.0 Catalytic Sorbant (Tri-Mer or equivalent) | 2.0 70 – 90% | 2.0 0.0012 lb/MMbtu | 2.0 70% ^{la} | |
| ^{la} Control effectiveness and emissions levels specified by vendor/supplier guarantee | | | | |

Best management practices for CO emissions for heaters and boilers are identified within the EPA RACT/BACT/LAER Clearinghouse as good combustion practices. Meridian has received supplier guarantee for CO emissions by implementation of good combustion practices with ultra-low NOx burners. This value is 0.028 lb/MMBTU.

For NOx emissions, Meridian will implement Ultra-Low NOx burners on all units as well as SCR controls on the larger units throughout the facility. Emissions values for both scenarios are based on vendor/supplier guarantees. Emissions for ultra-low NOx burners without SCR control are guaranteed at 0.03 lb/MMBTU. Emissions for low NOx burners with SCR control are guaranteed at 0.0012 lb/MMBTU. See Exhibit B for manufacturer guarantees for low NOx burners with and without SCR.

VOC emissions levels and control effectiveness were identified through review of EPA RACT/BACT/LAER Clearinghouse as well as through review of similar permit for a hydrogen plant in Louisiana.

For particulate emissions controls, Meridian has obtained a vendor/supplier guarantee for particulate emissions rate for good combustion practices of 0.004 lb/MMBTU – see Exhibit B.



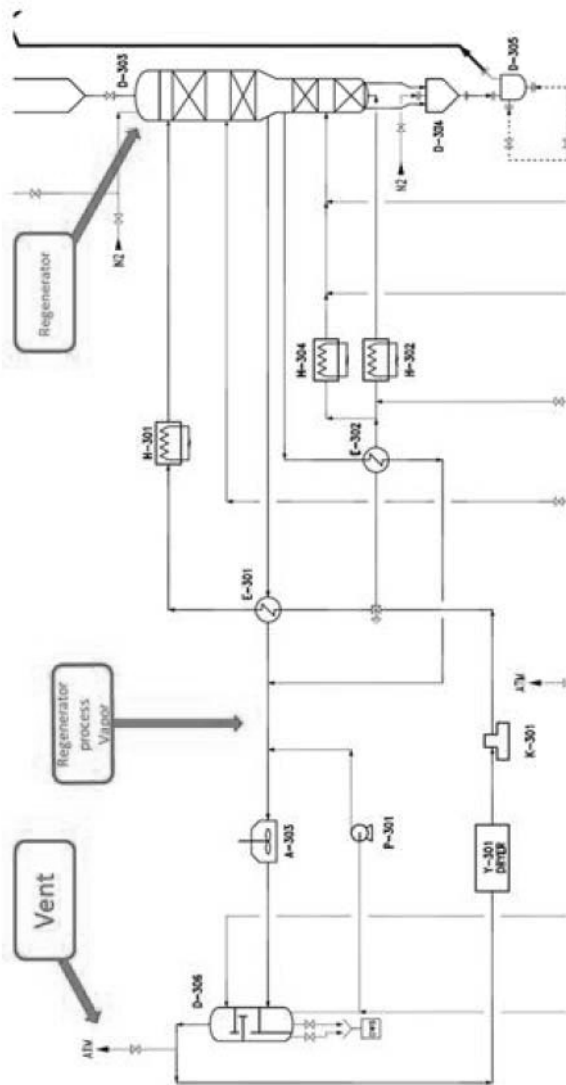
| | | |
|---|-----------------------------------|--|
|  | CONTROLS TECHNOLOGY REVIEW | VEPICA CODE: P-5715043-01-001-18035-1001 <hr/> COMPANY CODE: TBD <hr/> ISSUE: 1 DATE: 03/29/17 <hr/> SHEET: 14 OF 24 |
| | |  |

Table 4d: Davis Refinery – Summary of Applicable Air Pollution Control Technologies by Source Category
Catalytic Reforming Unit

| Technically Feasible Control Options | Identified Control Efficiency Ranges | Identified Emissions Ranges | Control Efficiency Used | Controlled Emission Factor Used |
|--|---------------------------------------|---------------------------------------|-------------------------|---------------------------------|
| VOCs | | | | |
| Applicable Feasible Technologies | | | | |
| NA | NA – must meet NSPS ^{la, lb} | NA – must meet NSPS ^{la, lb} | 0% ^{la} | 0.24 lb/Mbbl ^c |
| <p>^a RACT / BACT / LAER Clearinghouse & Permit for Motiva Enterprises LLC, Norco Refinery, Breton, Louisiana, Catalytic Reformer No. 2 Unit Fugitive Emissions (03/25/2008) = 120.57 TPY</p> <p>^b Must meet 40 CFR 60 SUBPART GGG, 40 CFR 63 SUBPART CC</p> <p>^c Technology Licensor (Axens) provided value using total hydrocarbons as surrogate for VOC emissions and taking into account mass balance.</p> | | | | |
| <p>Selected Technologies – NA, must meet NSPS</p> | | | | |



For CO, NOx, SOx and PM emissions, these are controlled through 100% capture and recirculation through the regenerator resulting in no emissions. There are no particulates in the regenerator gas either upstream or downstream of the wash drum. The water/caustic washing of regenerator gas is not an emission control process but rather is used to scrub remaining chlorides. Please see Process Flow Diagram of Axens' licensed regenerator system (shown at left) which shows how vent gas flows from the fixed-bed regenerator through a heat exchanger (E-301) and air cooler (A-303) prior to entering the wash drum (D-306). A small purge volume is vented from the wash drum outlet resulting in minor VOC emissions which are off-gassed as shown in the emissions inventory.



| | | | |
|---|--|----------------|---|
|  | CONTROLS TECHNOLOGY REVIEW | |  |
| | VEPICA CODE: P-5715043-01-001-18035-1001 | | |
| | COMPANY CODE: TBD | | |
| | ISSUE: 1 | DATE: 03/29/17 | |
| SHEET: 15 | OF 24 | | |

Table 4e: Davis Refinery – Summary of Applicable Air Pollution Control Technologies by Source Category
Sulfur Recovery Plant

| Technically Feasible Control Options | Identified Control Efficiency Ranges | Identified Emissions Ranges | Control Efficiency Used | Controlled Emission Factor Used |
|--|--|---|-------------------------|---------------------------------|
| SO₂ | | | | |
| Applicable Feasible Technologies^a | | | | |
| 1.0 Claus 2 Stages 2.0 Claus 3 Stages 3.0 Claus 4 Stages 4.0 LO-CAT with/ Tail Gas Treatment | 1. 93.5% for SO ₂ 2. 95.5% for SO ₂ 3. 96.5% for SO ₂ 4. >98.5% for H ₂ S in LO-CAT vent ^a which translates to >99.9% for SO ₂ from thermal oxidizer ^b | Selected Technologies – LO-CAT with vent gases routed to thermal oxidizer 1. 278 lb/ton of sulfur product 2. 188 lb/ton of sulfur product 3. 145 lb/ton of sulfur product 4. 4 lb/ton of sulfur product | 99.9% ^b | 1.15 ppm |
| ^a Texas Commission on Environmental Quality, Federal Operating Permit, Wason CO2 Recovery Plant, Yoakum County, TX (2015) | | | | |
| ^b RACT/BACT/LAER Clearinghouse & Permit for Venoco-Ellwood Onshore Facility, Thermal Oxidizer (LO-CAT oxidation air) (2011) | | | | |

Meridian will implement a Merichem Licensed LO-CAT system with vent gas from the LO-CAT system then routed to a thermal oxidizer. This effectively reduces SO₂ emissions to minimal levels. This is identified as BACT by TCEQ and EPA RACT/BACT/LAER Clearinghouse for similar applications. Claus technology although effective at capacities starting at 25 LTPY, will not be effective for the sulfur content loading expected in the Bakken feed. Mass balance calculations for the full capacity refinery indicate an annual production of around 11 LTPY.



| | | | | | |
|---|-----------------------------------|----------------|--|--|---|
|  | CONTROLS TECHNOLOGY REVIEW | | VEPICA CODE: P-5715043-01-001-18035-1001 | |  |
| | | | COMPANY CODE: TBD | | |
| | ISSUE: 1 | DATE: 03/29/17 | | | |
| | SHEET: 16 | OF 24 | | | |

Table 4f: Davis Refinery – Summary of Applicable Air Pollution Control Technologies by Source Category
Blowdown System

| Technically Feasible Control Options | Identified Control Efficiency Ranges | Identified Emissions Ranges | Control Efficiency Used | Controlled Emission Factor Used |
|---|--------------------------------------|-----------------------------|-------------------------|--|
| All Emissions | | | | |
| Applicable Feasible Technologies^{1a} | | | | |
| 1.0 Uncontrolled | 1.0 Base case | 1.0 0.586 lb/MMbtu (VOC) | | |
| 2.0 Vapor Recovery to flare | 2.0 99.8% | 2.0 0.0012 lb/MMbtu (VOC) | 99.8% ^{1a} | 0.0008 lb/MMbtu or 1.8 lb/hr ^{1a} |
| 3.0 Vapor Recovery to product capture w/ flaring during upset only | 3.0 Up to 100% | 3.0 0.0 lb/MMbtu (VOC) | | |
| ^{1a} Emissions Estimation Protocol for Petroleum Refineries, Version 3, Table 5.12 (RTI International, April 2015) Note: Values in lb/MMbtu are shown for VOC only as example. Other default values for CO, NOx, SO2 are shown in Table 5.12, reference ^{1a} | | | | |

Meridian will implement an aggressive vapor recovery system for the blowdown system. The captured vapors will be rerouted back into processes/product feed during normal operations. Routing of gases to flare from this unit will only occur for upset conditions. This approach is considered state of industry. Analysis of effectiveness of this system is discussed in detail in the referenced document (Emissions Estimation Protocol for Petroleum Refineries) which was completed under EPA contract by RTI International (2015).



| | | | | |
|---|-----------------------------------|----------------|--|---|
|  | CONTROLS TECHNOLOGY REVIEW | | VEPICA CODE: P-5715043-01-001-18035-1001 |  |
| | | | COMPANY CODE: TBD | |
| | ISSUE: 1 | DATE: 03/29/17 | | |
| | SHEET: 17 | OF 24 | | |

Table 4g: Davis Refinery – Summary of Applicable Air Pollution Control Technologies by Source Category
Flares

| Technically Feasible Control Options | Identified Control Efficiency Ranges | Identified Emissions Ranges | Control Efficiency Used | Controlled Emission Factor Used |
|---|--------------------------------------|--------------------------------|-------------------------|---------------------------------|
| All Emissions | | | | |
| Applicable Feasible Technologies^a | | | | |
| Flare systems are designed with vapor recovery units to address only upset conditions under minimal hours per year operations. Flare emissions are therefore de-minimus for all pollutants. | 98% + ^a | >300 btu/scf net heating value | Per EPA & NDDoH stds | Per EPA & NDDoH stds |
| Selected Technologies – emergency flaring during upset only | | | | |
| ^a AP 42 Emission Factors, Fifth Edition, Section 13.5, Industrial Flares | | | | |

For flare systems, the primary control is to structure the facility to utilize the flares only during true upset conditions. All vapor recovery units will collect vapors and route collected materials back to processes/product feed. For this reason flare systems are anticipated to be utilized for maximum of 168 hours per year each. Flare pilots will run full time however and emissions for these pilot units have been taken into account. Flare operation and control are specified by EPA and NDDoH standards.



| | | | | | |
|---|-----------------------------------|----------------|--|--|---|
|  | CONTROLS TECHNOLOGY REVIEW | | VEPICA CODE: P-5715043-01-001-18035-1001 | |  |
| | | | COMPANY CODE: TBD | | |
| | ISSUE: 1 | DATE: 03/29/17 | | | |
| | SHEET: 18 | OF 24 | | | |

Table 4h: Davis Refinery – Summary of Applicable Air Pollution Control Technologies by Source Category
Wastewater Treatment System

| Technically Feasible Control Options | Identified Control Efficiency Ranges | Identified Emissions Ranges | Control Efficiency Used | Controlled Emission Factor Used |
|---|---|-----------------------------|-----------------------------|---------------------------------|
| VOC / HAP | | | | |
| Applicable Feasible Technologies ^{1a} | Selected Technologies – All technologies identified as feasible will be installed in multiple overlay to maximize controls | | | |
| 1.0 Enclosed tanks and oil/water separators with vapor recovery | 99% ^{1a} Combined Controls | 0.400 TPY ^{1a} | 95% for VOC 55% for HAPs | 10.52 TPY VOC 0.52 TPY HAP |
| 2.0 VESP Unit (or equivalent) with API oil/water separators | | | | |
| 3.0 Diffused air flotation (DAF) units | | | | |
| ^{1a} RACT/BACT/LAER Clearinghouse and Permit Review for Magellan Processing, LP, Corpus Christi, Terminal, TX (2015) | | | | |

For the wastewater treatment system, the primary emissions of concern are VOCs and related HAPs. Meridian will implement enclosed tank systems with vapor recovery from the tanks. In addition, waters will be run through a BWON compliant plant which may include a VESP and/or covered oil water separator and a DAF system with vapor recovery from these units. The combination of these controls is anticipated to remove contaminants by at least 99%. However for calculation purposes, calculations were based on 95% control for VOCs and 55% control for HAPs.



| | | | |
|---|--|----------------|---|
|  | CONTROLS TECHNOLOGY REVIEW | |  |
| | VEPICA CODE: P-5715043-01-001-18035-1001 | | |
| | COMPANY CODE: TBD | | |
| | ISSUE: 1 | DATE: 03/29/17 | |
| SHEET: 19 OF 24 | | | |

Table 4j: Davis Refinery – Summary of Applicable Air Pollution Control Technologies by Source Category
Cooling Towers

| Technically Feasible Control Options | Identified Control Efficiency Ranges | Identified Emissions Ranges | Control Efficiency Used | Controlled Emission Factor Used |
|---|---|--|--|---------------------------------|
| PM10 / VOC | | | | |
| Applicable Feasible Technologies ^{a, b} | | Selected Technologies – PM10 – drift eliminators. VOC's periodic monitoring of water for hydrocarbons per regs. | | |
| 1.0 PM10 – drift eliminators ^{a, b} | Controls are inherent in process design for cooling tower for PM10 | None specifically identified | Controls are inherent in design for cooling tower for PM10 and are part water level monitoring for VOCs. | Project and site specific. |
| 2.0 VOC – periodic monitoring of flows for VOC's hydrocarbons ^{a, b} | and are part of hydrocarbon levels monitoring of waters for VOCs. | | | |
| ^a | Emissions Estimation Protocol for Petroleum Refineries, Version 3. Table 5.12 (RTI International, April 2015) | | | |

Cooling tower emissions and related controls are considered standard in the industry and are widely recognized as BACT.



| | | | |
|---|--|----------------|---|
|  | CONTROLS TECHNOLOGY REVIEW | |  |
| | VEPICA CODE: P-5715043-01-001-18035-1001 | | |
| | COMPANY CODE: TBD | | |
| | ISSUE: 1 | DATE: 03/29/17 | |
| | SHEET: 20 | OF 24 | |

Table 4j: Davis Refinery – Summary of Applicable Air Pollution Control Technologies by Source Category
Product Loading

| Technically Feasible Control Options | Identified Control Efficiency Ranges | Identified Emissions Ranges | Control Efficiency Used | Controlled Emission Factor Used |
|--|---|---|-------------------------|---|
| VOC | | | | |
| Applicable Feasible Technologies ^{1a} , | | | | |
| 1.0 Condensation vapor recovery systems | Generally 98% for new facilities ^{1a} per Loading Facilities MACT (40 CFR Part 63, Subpart BBBBBB) | Selected Technologies – vapor recovery to product recycle with upsets to emergency flares limited to 80 milligrams ^{1a} of TOCs per liter of gasoline Control | 98% | MACT per 40 CFR Part 63, Subpart BBBBBB |
| 2.0 Thermal oxidizer VOC / HAP control with low NOx burners. | | | | |
| 3.0 Testing of all tanker trucks for leaks | | | | |
| 4.0 Pressurized system. | | | | |
| ^{1a} | Emissions Estimation Protocol for Petroleum Refineries, Version 3. (RTI International, April 2015) | | | |

Meridian will implement an aggressive vapor recovery system for the product loading systems. The captured vapors will be rerouted back into product feed. Routing of captured vapors to flaring will only occur for upset conditions. This approach is considered state of industry. Analysis of effectiveness of this system is discussed in detail in the referenced document (Emissions Estimation Protocol for Petroleum Refineries) which was completed under EPA contract by RTI International (2015). Maximum allowable emissions and well as controls approaches are specified by MACT standards.





| | | | | |
|---|-----------------------------------|----------------|--|---|
|  | CONTROLS TECHNOLOGY REVIEW | | VEPICA CODE: P-5715043-01-001-18035-1001 |  |
| | | | COMPANY CODE: TBD | |
| | ISSUE: 1 | DATE: 03/29/17 | | |
| | SHEET: 21 | OF 24 | | |

Table 4k: Davis Refinery – Summary of Applicable Air Pollution Control Technologies by Source Category
Fugitive Vehicular Emissions

| Technically Feasible Control Options | Identified Control Efficiency Ranges | Identified Emissions Ranges | Control Efficiency Used | Controlled Emission Factor Used |
|--|--|-----------------------------|-------------------------|--|
| PM | | | | |
| Applicable Feasible Technologies ^(a) | | | | |
| 1.0 Paving 2.0 Speed Controls | Primary control is paving vs no paving. Base condition is paving | NA | NA | PM _{2.5} - 0.00054 lb/vmt PM ₁₀ - 0.0022 lb/vmt Silt load = 2.15E-02 |
| ^a AP 42 Emission Factors, Fifth Edition, Volume I, Section 13.2.1. Paved Roads, Silt loading factor for limited access roads, page 13.2.1-9 | | | | |

Control of fugitive area emissions from roadways and parking areas will be through paving of these areas as well as control of vehicle speeds. All routinely traveled roadway areas as well as parking lot areas will be paved. All roadways will be posted to maintain on-site speed limits to below 15 mph. Paving and speed controls are considered BACT for control of emissions from these areas



| | | | |
|---|---|--|---|
|  | CONTROLS TECHNOLOGY REVIEW | VEPICA CODE: P-5715043-01-001-18035-I001 |  |
| | | COMPANY CODE: TBD | |
| | | ISSUE: 1 DATE: 03/23/17 | |
| | | SHEET: 22 OF 24 | |

3.1. Summary of Proposed Controls

Since the proposed Davis Refinery is a new refinery, it has allowed Meridian to aggressively pursue emissions controls throughout the plant emissions sources. To assure the level of control required can be achieved, in order to qualify as a Synthetic Minor Source, proposed controls have been “stacked”. For this reason, in several instances the facility is redefining what can be achieved as BACT and as a result, there is minimal literature available to confirm some values. In these instances we have relied on mass balance calculations, good engineering practice and speciation analysis of the airstream. When applicable manufacturer guarantees are provided in Exhibit B. Table 5 below presents an overall summary of proposed emission controls across the proposed Davis Refinery.



Table 5. Davis Refinery Summary of Proposed Emissions Controls

| Source/Unit | Target Pollutant | Pollution Control Technologies Used | Assumed % Control |
|---|------------------------------|---|---|
| Leaks (Fugitive Emissions) | VOC | LDAR (Leak, Detection and Repair) program with differential light absorption and ranging (DIAL) or optical gas imaging (OGI) technology. | 97% (valves), 85% pumps, 97% flanges, 97% sample points, (30% heavies) Program baseline of 500 ppm |
| Tanks | VOC | IFRs with Double Seal and Wipers | NESHAP std |
| Stationary Combustion Sources (Process Unit Furnaces and Utility Boilers) | CO NOx Org. HAPs | CO – Good Comb. Practices w/ Ultra Low NOx Burners NOx – SCR’s w/ Ultra Low NOx Burners Org. HAPs – Good Comb. Practices w/ Ultra Low NOx Burners | CO – 96% NOx – 75% Org. HAPs – 75% |
| Catalytic Reforming Unit (Regeneration Vent) | VOC HAPs | NA – minor emissions levels | NA – de-minimus |
| Sulfur Recovery Plants | SO ₂ | Lo-CAT with vent gases routed to thermal oxidizer. Other pollutants considered minor. | SO ₂ - 99.9% |
| Blowdown System | CO NOx SO ₂ | Vapor recovery to product capture and emergency flaring only for upsets | 99.8% |
| Flares | CO NOx VOC HAPs | Lower heating value of feed gases, requirements specified by EPA and NDDoH regulations. Emergency flaring for upset conditions only. | 98% + |
| Wastewater Treatment System | VOC HAPs | Covered API/CPI oil/water separators and induced/dissolved air flotation units Equalization tanks instead of open ponds. Vapor Recovery System | VOC – 95% HAPs – 55% |
| Product Loading | VOC | Vapor recovery to product recycle with upsets to emergency flares | 98% |
| Fugitive (on-site vehicular) emissions | PM | Paving of areas of routine vehicle traffic. Maintain vehicle speeds to < 15 mph | PM _{2.5} - 0.00054 lb/vmt PM ₁₀ - 0.0022 lb/vmt Silt load = 2.15E-02 |
| Spent Catalyst | PM | De-minimus | NA – de-minimus |

| | | | |
|---|---|---|---|
|  | CONTROLS TECHNOLOGY REVIEW | VEPICA CODE: P-5715043-01-001-18035-I001 |  |
| | | COMPANY CODE: TBD | |
| | | ISSUE: 1 DATE: 03/23/17 | |
| | | SHEET: 23 OF 24 | |

4. REFERENCES

- 40 CFR 63, Subpart CC & 40 CFR 60, Subpart GGG
- A. Armendariz, 2008, The Costs and Benefits of Selective Catalytic Reduction on Cement Kilns for Multi-Pollutant Control
- Barthe, P; Chaugny, M; Roudier, S & Delgado, L. 2015. Best Available Techniques (BAT) Reference Document for the Refining of Mineral Oil and Gas. JRC Science and Policy Reports
- Dunn, T.; Breen, D. 2003. Potential Control Strategies to Reduce Emissions from Refinery Wastewater Collection and Treatment Systems. California Air Resources Board and the Bay Area Air Quality Management District.
- EPA, Leak Detection and Repair – A Best Practices Guide, EPA-305-D-07-001 October 2007
- EPA Notification, 18th March, 2008, G.S.R 186(E),
- EPA RACT/BACT/LAER Clearinghouse for Petroleum Refining Equipment Fugitive Leaks
- EPA RACT/BACT LAER Clearinghouse for Catalytic Reformer Units
- EPA Control Techniques Guidelines for the Oil and Natural Gas Industry (Draft, 2015)
- EPA, AP 42 Emission Factors, Fifth Edition, Section 8.13, Sulfur Recovery
- EPA, AP 42 Emission Factors, Fifth Edition, Section 13.5, Industrial Flares
- EPA, AP 42 Emission Factors, Fifth Edition, Volume I, Section 13.2.1. Paved Roads, Silt loading factor for limited access roads, page 13.2.1-9
- EPA/ RTI International, April 2015, Emissions Estimation Protocol for Petroleum Refineries, Version 3. Table 5.12
- Engineering Documentation from BASIC and Process calculations from VEPICA.
- Eastern Research Group, Inc. 1997. Preferred And Alternative Methods For Estimating Air Emissions From Wastewater Collection And Treatment. Prepared for Point Sources Committee, Emission Inventory Improvement Program, Emission Factor and Inventory Group, U.S. EPA.
- Johnson Matthey Process Technologies website: <http://www.improtech.com/sox-reduction-johnson%20matthey-intercat>).
- Mo, X.; De Graff, B.; Radcliffe C. and Diddams, P. 2014. HCN and NOx control strategies in the FCC. From www.digitalrefining.com/article/1000926.

| | | | |
|---|---|---|---|
|  Meridian Energy Group Inc. | CONTROLS TECHNOLOGY REVIEW | VEPICA CODE: P-5715043-01-001-18035-I001 |  |
| | | COMPANY CODE: TBD | |
| | | ISSUE: 1 DATE: 03/23/17 | |
| | | SHEET: 24 OF 24 | |

- TCEQ – Control Efficiencies for TCEQ Leak Detection and Repair Programs Revised 07/11 (APDG 6129v2)
- Utah Division of Air Quality Source Plan Review, Permit Review for Magallen Processing, LP, Corpus Christi, Terminal, TX (2015)
- Utah Division of Air Quality Source Plan Review, Holly Refining Heavy Crude Processing Project, Davis County, UT (2013)
- VEPICA, 2016. Emissions Inventory for Davis Refinery. Document N°P-5715043-00-001-18042-I001.
- Wakefield, B. 2007. The Environmental Integrity Project. Oil Refinery Permits. A Handbook for Citizen Participation in the Permitting of Oil Refineries under the New Source Review Provisions of the Clean Air Act.

Exhibit D: Emissions Dispersion Modeling and Air Quality Impact Analysis

NHOE-16-001-16-419

SUMMARY REPORT OF AIR DISPERSION MODELING RESULTS

IN SUPPORT OF AN APPLICATION FOR
AIR CONTAMINANT DISCHARGE PERMIT
MERIDIAN ENERGY GROUP, INC.
DAVIS REFINERY
BILLINGS COUNTY, NORTH DAKOTA

APRIL 2017



201 N. Church Street,
Suite 300
Las Cruces, NM 88001
Phone (575) 532-1526
Fax (575) 532-1587

SUMMARY REPORT OF AIR DISPERSION MODELING RESULTS

IN SUPPORT OF AN APPLICATION AMENDMENT FOR
AIR CONTAMINANT DISCHARGE PERMIT

MERIDIAN ENERGY GROUP, INC.
DAVIS REFINERY
BILLINGS COUNTY, NORTH DAKOTA

*Zia Project # NHOE-16-001
Document # NHOE-16-001-16-419
Submission Date: April 2017*

Submitted To: **North Dakota Department of Health
Air Quality Division**

On behalf of: **VEPICA USA, Inc.
2002 W Grand Parkway North, Suite 200
Katy, TX 77449**

Submitted by:

Author(s):



201 N. Church Street, Suite 300
Las Cruces, New Mexico 88001
(575) 532-1526 voice
(575) 532-1587 fax

Miguel A. Martinez

Edward H. Martinez, PE

TABLE OF CONTENTS

| | | |
|------------|--|-----------|
| 1.0 | INTRODUCTION..... | 1 |
| 1.1 | Proposed Project..... | 1 |
| 1.2 | General Regulatory Overview | 2 |
| 2.0 | CRITERIA POLLUTANTS ANALYSIS REQUIREMENTS | 3 |
| 3.0 | CRITERIA POLLUTANT MODEL APPROACH | 5 |
| 3.1 | Introduction..... | 5 |
| 3.2 | Screening Analysis..... | 5 |
| 3.3 | Refined Analyses (SIL and Cumulative)..... | 6 |
| 3.3.1 | Model Selection | 6 |
| 3.3.2 | Emissions Inventory..... | 6 |
| 3.3.3 | Meteorological Data | 8 |
| 3.3.4 | Receptor Locations | 9 |
| 3.3.5 | Background Concentrations | 10 |
| 3.4 | Aermod Execution | 10 |
| 3.5 | Interpretation of Aermod Model Output | 11 |
| 4.0 | AIR TOXICS ANALYSIS | 15 |
| 4.1 | Introduction..... | 15 |
| 4.2 | Compliance Determination Procedure | 15 |
| 4.3 | Air Toxics Analysis Results | 16 |
| 5.0 | PLUME VISIBILITY ANALYSIS | 16 |
| 5.1 | Introduction..... | 16 |
| 5.2 | Visibility Analysis Procedure | 17 |
| 5.3 | Summary of Visibility Analysis Results..... | 17 |

LIST OF ATTACHMENTS

- Attachment A – Electronic Files Lists and Titles
- Attachment B – Air Quality Dispersion Analysis Guide
- Attachment C – Emissions Sources Characteristics
- Attachment D – Air Toxics Analysis Spreadsheets
- Attachment E – Cooling Tower Visibility Study

LIST OF TABLES

Table 1a – Preliminary Summary of Potential to Emit – Primary Operating Scenario 4

Table 1b – Preliminary Summary of Potential to Emit – Alternative Operating Scenario,
 Phase I 4

Table 2 – Summary of NAAQS Significant Impact Levels ($\mu\text{g}/\text{m}^3$)
 For Preliminary Screening Analysis 5

Table 3 – Calculation of Virtual Stack Model Characteristics 7

Table 4 – Virtual Stack Modeled Characteristics 8

Table 5 – Non-Uniform Cartesian Grid, Distance and Interval Distribution..... 9

Table 6 – Requested Additional Receptors 9

Table 7a – Summary of Modeled Highest Values Compared to NDDoH SILs ($\mu\text{g}/\text{m}^3$) –
 Primary Operating Scenario 12

Table 7b – Summary of Modeled Highest Values Compared to NDDoH SILs ($\mu\text{g}/\text{m}^3$) –
 Alternative Operating Scenario 12

Table 8a – Class I Areas PSD Increments and Significant Impact Levels
 Primary Operating Scenario 13

Table 8b – Class I Areas PSD Increments and Significant Impact Levels
 Alternative Operating Scenario 13

Table 9a – Class II Areas PSD Increments and Significant Impact Levels
 Primary Operating Scenario 14

Table 9b – Class II Areas PSD Increments and Significant Impact Levels
 Alternative Operating Scenario 14

Table 10 – Visible Plumes Above the Buckhill Trail Horizon (Easterly Direction)..... 17

SUMMARY REPORT OF AIR DISPERSION MODELING RESULTS

1.0 INTRODUCTION

1.1 PROPOSED PROJECT

Meridian Energy Group, Inc. (Meridian) has applied for a Permit to Construct (PTC) for the proposed Davis Refinery (the "Project") from the North Dakota Department of Health (NDDoH) Division of Air Quality. The Davis Refinery will be an approximately 55,000 barrels per day ("bpd") high-conversion, crude refinery that will produce a full slate of refined products and specialty chemicals. Meridian has initiated engineering plans and the Project design is based upon the availability of process equipment that will shorten the schedule and reduce costs while ensuring environmental compliance.

The Project location is a 620-acre site in Billings County, North Dakota (see Figure 1 - the "Site") where Meridian has entered into an option-purchase agreement with the owner. On July 5th, 2016 the Billings County Board of Commissioners unanimously approved a rezoning permit that changed the Site's use to "industrial" in order to allow the construction of the Project on this property. Figure 1 provides a map of the proposed project site and immediate area.

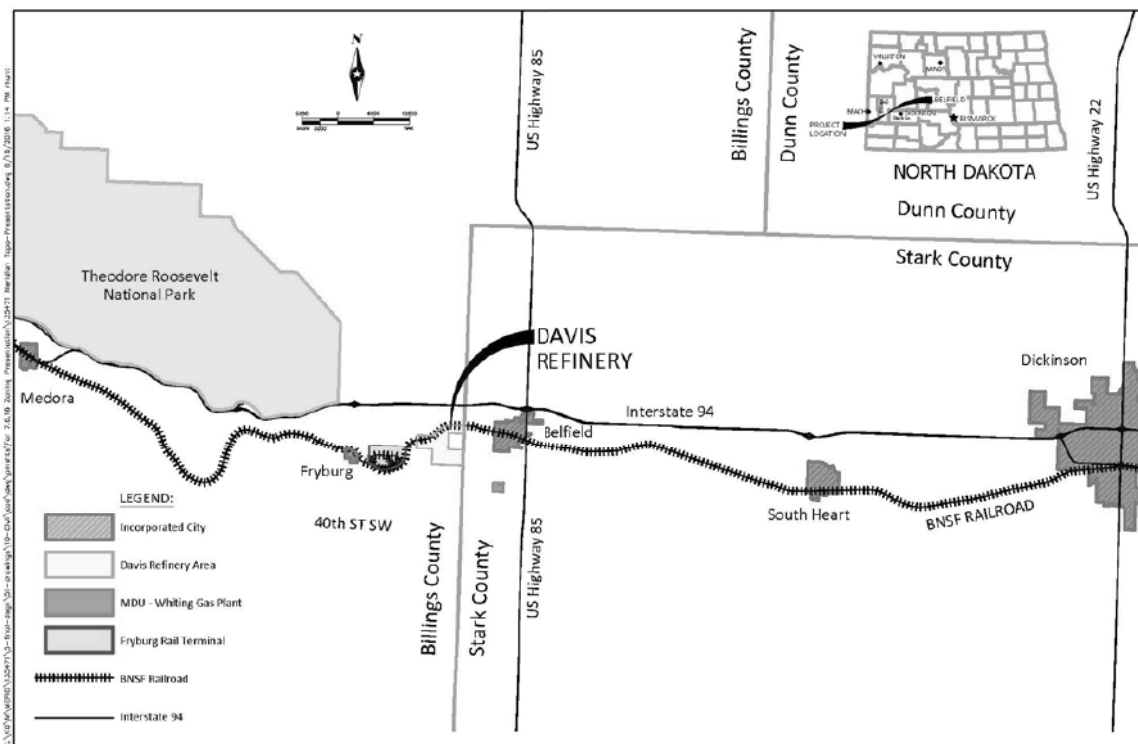


Figure 1: Proposed Site Location Davis Refinery Project, Billings County, ND

The terrain generally rises toward the north and west ends of the property and falls away from the site toward the south and east. The highest locations in proximity to the site are approximately 12-20 kilometers away and within the boundaries of the nearby Theodore Roosevelt National Park (TRNP), which is situated to the west of the Site. A review of the land use in the immediate area (2 mi. - 3 kilometers (km)) indicates that the subject site is in a rural, farmland area.

1.2 GENERAL REGULATORY OVERVIEW

As noted, Meridian submitted a PTC application for this project to the NDDoH in October 2016 and is submitting the present document as an amendment of the prior 2016 submittal. As part of the process of obtaining a PTC and based on review of NDDoH guidance and criteria, the NDDoH is requiring air impacts modeling of the facility's potential emissions to surrounding lands. This is due to the Site's proximity to the TRNP and the high level of public interest in the project. This "Summary Report of Model Results" describes the refined analysis that Zia Engineering and Environmental Consultants, LLC (Zia) has performed on behalf of Meridian and their primary consultant Vepica USA, Inc. (Vepica).

The subject site is located in an area that currently meets all air attainment standards for all criteria pollutants. The project triggers new source review requirements of the NDDoH under "Designated Air Contaminant Sources Permit to Construct" rules (Chapter 33-15-14) as well as related NDDoH permitting and modeling guidance.

Included in this report is discussion of the analysis and modeling approach as well as summary discussion of results. Specifically, this document summarizes the modeling evaluation of the facility's short range (20 km) air quality impacts in Class II areas as along with the preliminary analysis of impacts to the nearby Class I area (TRNP – South Unit).

As stated in the New Source Review Workshop Manual (Draft 1990) in relation to Prevention of Significant Deterioration (PSD) permitting: "Class I areas are areas of special national or regional natural, scenic, recreational, or historic value for which the PSD regulations provide special protection." "One way in which air quality degradation is limited in all Class I areas is by stringent limits defined by the Class I increments for sulfur dioxides, particulate matter and nitrogen dioxide. In addition, the Federal Land Manager (FLM) of each Class I area is charged with the affirmative responsibility to protect unique attributes of the area, expressed generically as air quality related values (AQRV's)."

The proposed project location is approximately 4 kilometers southeast of the South Unit of TRNP, a designated Class I area. Due to the close proximity of the project to the Class I area, air dispersion modeling of potential impacts to the Class I area is required by NDDoH in accordance with the NDDoH's requirements defined in the "Criteria Pollutant Modeling Requirements for a Permit to Construct" memo dated October 6, 2014 as well as the project specific NDDoH "Site Specific Modeling Guidance" issued for the project and dated June 20, 2016.

Also included with this Summary Report submittal are electronic copies of all input and output files of the model analysis as well as related electronic copies of spreadsheets used to support the analysis. File name references and file titles are included as Attachment A of this document. This report includes analyses and discussions of both criteria pollutant impacts under New Source Review Standards (NSR) and air toxics impacts under the NDDoH Air Toxics Policy and specifically under Section 33-15-02-04, subsection 3 of the North Dakota Air Pollution Control Rules.

In addition, the North Dakota Department of Health Air Quality Department requested a non-regulatory visibility study to determine if the cooling tower condensation plume rise from the proposed North Dakota Davis Refinery (NDDR) site would be visible at observation points at the Theodore Roosevelt National Park. The results of the requested visibility studies are provided in Attachment E of this report for informational purposes only. This visibility analysis has no regulatory criteria or basis but is provided for information purposes only.

2.0 CRITERIA POLLUTANTS ANALYSIS REQUIREMENTS

The Project is a 55,000 bpd oil refinery facility. However, as shown in Table 1 and based on the proposed level of controls, the facility qualifies as a synthetic minor source. More detailed discussions of emissions estimates and facility and emissions controls is included in the PTC document (Exhibit B) and related supporting submittals. As a synthetic minor source, it does not meet PSD major source triggers for any of the criteria pollutants. However, based on its location near a Class I area, as well as the general level of public interest, the NDDoH is requiring at least screen modeling analysis for both Class I and Class II National Ambient Air Quality Standards (NAAQS) Significant Impact Levels (SILs). Shown in Table 2 is a summary of the NAAQS SILs that the facility is required to meet for preliminary screening analysis. To conduct this modeling analysis, initially, Class I and Class II Significant Impact Level (SIL) modeling is conducted. If the initial screen modeling does not exceed Class I and Class II SILs, further dispersion modeling is not required. If the initial screen modeling exceeds Class I or Class II SILs, then refined dispersion modeling must be conducted for PSD increment consumption and Federal and State Ambient Air Quality Standards (AAQS).

The NDDoH Division of Air Quality (DAQ) has primary jurisdiction for permitting and operating issues involving air quality at the subject site. As such, the Project is required to comply with the applicable sections of the NDDoH "Criteria Pollutant Modeling Requirements for a Permit to Construct" memo dated October 6, 2014 as well as the project specific NDDoH "Site Specific Modeling Guidance" issued for the project and dated June 20, 2016, as applicable. The model analysis associated with this permit amendment was completed in compliance with these modeling requirements.

Table 1a – Preliminary Summary of Potential to Emit – Primary Operating Scenario
 Davis Refinery Project, Billings County, ND

| Emission Units | Criteria Pollutants | | | | | | | | | | HAPs |
|-------------------------------|---------------------|-----------------|--------------|-------------------|--------------|--------------------|----------------|---------------------------|-----------------|--------------|--------------|
| | CO | Pb | PM<10 | Filterable PM <10 | PM <2.5 | Filterable PM <2.5 | Condensable PM | NOx (as NO ₂) | SO ₂ | VOC | Total HAPs |
| Leaks | 0.00 | 0.00 | 0.00 | 0.00 | 0.00 | 0.00 | 0.00 | 0.00 | 0.00 | 16.70 | 1.51 |
| Tanks | 0.00 | 0.00 | 0.00 | 0.00 | 0.00 | 0.00 | 0.00 | 0.00 | 0.00 | 7.43 | 8.55 |
| Stationary Combustion Sources | 76.16 | 1.33E-03 | 10.88 | 2.72 | 10.88 | 2.72 | 8.16 | 34.51 | 1.60 | 14.67 | 1.35 |
| Catalytic Reforming Unit | 0.00 | 0.00 | 0.00 | 0.00 | 0.00 | 0.00 | 0.00 | 0.00 | 0.00 | 0.71 | 0.07 |
| Sulfur Recovery Plant | 2.36 | 0.00 | 0.00 | 0.00 | 0.00 | 0.00 | 0.00 | 0.52 | 0.22 | 1.65 | 0.00 |
| Vacuum Systems | 0.00 | 0.00 | 0.00 | 0.00 | 0.00 | 0.00 | 0.00 | 0.00 | 0.00 | 0.00 | 0.00 |
| Blowdown System | 0.83 | 0.00 | 0.01 | 0.01 | 0.01 | 0.01 | 0.00 | 3.66 | 5.20 | 0.15 | 0.00 |
| Flares | 0.25 | 4.38E-06 | 0.04 | 0.01 | 0.04 | 0.01 | 0.03 | 0.27 | 0.005 | 0.05 | 0.00 |
| Wastewater | 0.00 | 0.00 | 0.00 | 0.00 | 0.00 | 0.00 | 0.00 | 0.00 | 0.00 | 14.54 | 0.72 |
| Cooling Towers | 0.00 | 0.00 | 2.07 | 0.00 | 0.00 | 0.00 | 0.00 | 0.00 | 0.00 | 0.39 | 0.00 |
| Truck Product Loading | 0.00 | 0.00 | 0.00 | 0.00 | 0.00 | 0.00 | 0.00 | 0.00 | 0.00 | 5.34 | 0.00 |
| Fugitive Dust | 0.00 | 0.00 | 0.00 | 0.00 | 9.72E-04 | 0.00 | 0.00 | 0.00 | 0.00 | 0.00 | 0.00 |
| Total STPY | 79.60 | 1.34E-03 | 12.99 | 2.73 | 10.92 | 2.73 | 8.19 | 38.95 | 7.02 | 61.63 | 12.21 |

Table 1b – Preliminary Summary of Potential to Emit – Alternative Operating Scenario, Phase I
 Davis Refinery Project, Billings County, ND

| Emission Units | Criteria Pollutants | | | | | | | | | | HAPs |
|-------------------------------|---------------------|-----------------|-------------|-------------------|-------------|--------------------|----------------|---------------------------|-----------------|--------------|--------------|
| | CO | Pb | PM<10 | Filterable PM <10 | PM <2.5 | Filterable PM <2.5 | Condensable PM | NOx (as NO ₂) | SO ₂ | VOC | Total HAPs |
| Leaks | 0.00 | 0.00 | 0.00 | 0.00 | 0.00 | 0.00 | 0.00 | 0.00 | 0.00 | 10.27 | 1.20 |
| Tanks | 0.00 | 0.00 | 0.00 | 0.00 | 0.00 | 0.00 | 0.00 | 0.00 | 0.00 | 6.66 | 8.55 |
| Stationary Combustion Sources | 25.34 | 3.86E-04 | 3.15 | 0.79 | 3.15 | 0.79 | 2.37 | 10.89 | 0.46 | 4.25 | 0.39 |
| Catalytic Reforming Unit | 0.00 | 0.00 | 0.00 | 0.00 | 0.00 | 0.00 | 0.00 | 0.00 | 0.00 | 0.06 | 0.01 |
| Sulfur Recovery Plant | 0.42 | 0.00 | 0.00 | 0.00 | 0.00 | 0.00 | 0.00 | 0.09 | 0.04 | 0.29 | 0.00 |
| Vacuum Systems | 0.00 | 0.00 | 0.00 | 0.00 | 0.00 | 0.00 | 0.00 | 0.00 | 0.00 | 0.00 | 0.00 |
| Blowdown System | 0.41 | 0.00 | 0.00 | 0.00 | 0.00 | 0.00 | 0.00 | 1.83 | 2.60 | 0.08 | 0.00 |
| Flares | 0.29 | 3.72E-06 | 0.03 | 0.01 | 0.03 | 0.01 | 0.02 | 0.23 | 0.004 | 0.04 | 0.00 |
| Wastewater | 0.00 | 0.00 | 0.00 | 0.00 | 0.00 | 0.00 | 0.00 | 0.00 | 0.00 | 9.62 | 0.48 |
| Cooling Towers | 0.00 | 0.00 | 0.52 | 0.00 | 0.00 | 0.00 | 0.00 | 0.00 | 0.00 | 0.10 | 0.00 |
| Truck Product Loading | 0.00 | 0.00 | 0.00 | 0.00 | 0.00 | 0.00 | 0.00 | 0.00 | 0.00 | 5.34 | 0.00 |
| Fugitive Dust | 0.00 | 0.00 | 0.00 | 0.00 | 9.72E-04 | 0.00 | 0.00 | 0.00 | 0.00 | 0.00 | 0.00 |
| Total STPY | 26.46 | 3.90E-04 | 3.71 | 0.80 | 3.19 | 0.80 | 2.39 | 13.04 | 3.11 | 36.71 | 10.62 |

**Table 2 – Summary of NAAQS Significant Impact Levels ($\mu\text{g}/\text{m}^3$) For Preliminary Screening Analysis
Davis Refinery Project, Billings County, ND**

| Pollutant | 1-hour | | 3-hour | | 8-hour | | 24-hour | | Annual | |
|-------------------|---------|----------|---------|----------|---------|----------|---------|----------|---------|----------|
| | Class I | Class II | Class I | Class II | Class I | Class II | Class I | Class II | Class I | Class II |
| SO ₂ | -- | 7.8 | 1.0 | 25 | -- | -- | 0.2 | 5 | 0.1 | 1 |
| NO ₂ | -- | 7.5 | -- | -- | -- | -- | -- | -- | 0.1 | 1 |
| PM ₁₀ | -- | -- | -- | -- | -- | -- | 0.2 | 5 | 0.1 | 1 |
| PM _{2.5} | -- | -- | -- | -- | -- | -- | 0.07 | 1.2 | 0.06 | 0.3 |
| CO | | 2,000 | -- | -- | -- | 500 | -- | -- | -- | -- |

3.0 CRITERIA POLLUTANT MODEL APPROACH

3.1 INTRODUCTION

Zia conducted the air quality modeling using applicable sections of the NDDoH “Criteria Pollutant Modeling Requirements for a Permit to Construct” memo dated October 6, 2014 as well as the project specific NDDoH “Site Specific Modeling Guidance” issued for the project by the agency and dated June 20, 2016, as applicable. In addition, Zia had previously prepared and submitted “Modeling Protocol” document dated August 2016 that summarized proposed approach and methods for the modeling analysis. Comments from the NDDoH were received on September 16, 2016 and responded to and were followed in this modeling effort. Discussion of Zia’s approach is included in subsequent sections of this document and compliance with guidance criteria is structured per the NDDoH, “Air Quality Dispersion Modeling Analysis Guide” (June 21, 2013). A copy of this document is included in Attachment B. The permit amendment modeling followed the modeling protocol guidance used for the original permit to construct submittal.

Model analysis results are detailed in Section 3.3 of this report. These results show that preliminary screen modeling results in impacts below the identified Class I and Class II SILs. Thus, analysis approach and results are structured to support discussion of the comparison to the SILs since no further criteria pollutant modeling analysis is otherwise required.

3.2 SCREENING ANALYSIS

Based on the level of modeling required by the NDDoH as well as the anticipated heightened level of interest related to the project and its potential impacts, screening analysis using either AERSCREEN or SCREEN3 was not conducted for this project. Instead, refined analysis is discussed under Section 3.3 was completed.

3.3 REFINED ANALYSES (SIL AND CUMULATIVE)

3.3.1 Model Selection

The air dispersion model used for the screen analysis was AERMOD with the BREEZE Software graphic user interface to load the data into the applicable EPA modules. The module versions used are as follows:

- AERMOD 15181 (Recommended)
- AERMOD 12345 for the New Hourly NO2 NAAQS
- AERMET 15181
- AERMAP 11103
- AERSURFACE 13016
- BPIPFRM 040421

The proposed refinery site is located approximately 3.5 km west of Belfield, ND. The geometric mean of the battery limits for the facility is:

UTM Coordinates, WGS84 datum
13T (Northern Hemisphere)
633538.294 m E
5193515.636 m N

The proposed site was surveyed and the resulting plot plan was referenced to UTM coordinates using AUTOCAD. The model used the georeferenced plot plan to determine the coordinate of the individual sources, stacks, and points of interest.

3.3.2 Emissions Inventory

Point Source Characteristics

Included in Attachment C of this document are the Source Characteristics with the applicable physical characteristics of the point sources modeled in this analysis.

The model used National Elevation Data (NED) data downloaded from the USGS Nation Map website to determine the elevation of the sources and receptors. The USGS returned a .TIFF file bound by the following coordinates:

- North 46.628 N -103.25 E
- South 46.628 N -103.30 E
- West 46.876 N -103.61 E
- East 46.835 N -103.61 E

The elevation data extends 110 km by 93 km in the easterly and northern directions, respectively. The proposed North Dakota David Refinery (NDDR) site and TRNP are within the boundaries of the downloaded elevation data. The extent of the region allows the variable receptor grid to extend 25 km from fence line of the site in the direction of each compass point. The data were processed with AERMAP to extract the elevation of all sources and the park receptors, as well as their hill height scale.

Source Variable Stack Characteristics

There are two operating scenarios included in the analysis for this project. The Primary Operating Scenario, which is also described as Phase II, includes full build-out of the project at a total maximum production capacity of 55,000 bpd with all anticipated emissions units and controls included. The Alternative Operating Scenario is described as Phase I build-out of the project, which is anticipated for the first 2 to 3 years of operation. The Phase I operation is proposed to be approximately 27,500 bpd. Besides overall production capacity, the primary difference between the Primary Operating Scenario and the Alternative Scenario involves a delay in the installation of some production units, which will not be installed until Phase II, along with the delay of some production volumes.

Both operating scenarios were separately modeled for this analysis and the results of each analysis were compared to applicable SILs. A discussion of results is included in Section 3.5 of this report.

Stack Exit Velocity Adjustments

All stacks within the proposed site are vertical. Thus, the adjustments for horizontal or capped stacks prescribed in the AERMOD Implementation Guide (08/03/2015) were not necessary.

Flare Point Source Characteristics

The flare characteristics were calculated using the November 10, 2010 NDDoH “Model Inputs for Flare” guidelines. The results of the calculations are as follows:

**Table 3 – Calculation of Virtual Stack Model Characteristics
Davis Refinery Project, Billings County, ND**

| ID | FLARE | X | Y | Elevation | Flare LHV | | Net Heat Release | Stack Height | Flame Length | Virtual Stack Height | Virtual Stack Diameter |
|--------|-----------------------------|--------|---------|-----------|-----------|------------|------------------|--------------|--------------|----------------------|------------------------|
| | | | | (m) | MMBTU/h | Qt (Cal/s) | Q (cal/s) | Hs (m) | Hf (m) | hse (m) | Ds (m) |
| .5 | Enclosed HC Operating Flare | 633601 | 5193607 | 808.9 | 0.624 | 43680 | 19656 | 15 | 0.75 | 15.8 | 0.1 |
| FL1702 | Acid Flare | 633495 | 5193666 | 808.9 | 0.104 | 7280 | 3276 | 45 | 0.32 | 45.3 | 0.04 |
| FL1703 | HC Emergency Flare #1 | 633350 | 5193594 | 810.8 | 0.156 | 10920 | 4914 | 45 | 0.39 | 45.4 | 0.05 |
| FL1704 | HC Emergency Flare #2 | 633492 | 5193666 | 809 | 0.156 | 10920 | 4914 | 45 | 0.39 | 45.4 | 0.05 |

Source: Flare Dimension Calculations.xlsx

The virtual stack characteristics were then entered into the model, along with the recommendation of a stack velocity of 40 m/s, and a stack temperature of 1000 K.

**Table 4 – Virtual Stack Modeled Characteristics
Davis Refinery Project, Billings County, ND**

| ID | FLARE | X | Y | Stack Model Characteristic | | | | |
|--------|-----------------------------|--------|---------|----------------------------|------------|--------------|----------------|-----------------|
| | | | | Elevation (m) | Height (m) | Diameter (m) | Velocity (m/s) | Temperature (K) |
| FL1701 | Enclosed HC Operating Flare | 633601 | 5193607 | 808.9 | 15.8 | 0.1 | 40 | 1000 |
| FL1702 | Acid Flare | 633495 | 5193666 | 808.9 | 45.3 | 0.04 | 40 | 1000 |
| FL1703 | HC Emergency Flare #1 | 63350 | 5193594 | 810.8 | 45.4 | 0.05 | 40 | 1000 |
| FL1704 | HC Emergency Flare #2 | 633492 | 5193666 | 809 | 45.4 | 0.05 | 40 | 1000 |

Source: Flare Dimension Calculations.xlsx

Building Downwash

AERMOD and BPIPPRM, a building profile input program (BPIP) for the PRIME algorithm incorporated into the AERMOD program, were used together to determine the Good Engineering Practice Stack Heights (GEP Stack) and the building downwash. BPIP calculated the building height, length, and effective building width for 36 wind directions and provided the X and Y offsets for the adjustment routines. The model also included the storage tanks for the refinery as buildings. This enabled the model to consider the possible contribution of the storage tanks to building downwash. The model files for the BPIP analysis are as shown below with electronic copies of these files provided as Attachment A in this report.

- *Phase I BPIP 032117 Input File.txt*
- *Phase I BPIP 032117 Output File.txt*
- *Phase I BPIP 032117 Summary File.txt*
- *Phase II BPIP 032317 Input.txt*
- *Phase II BPIP 032317 Output.txt*
- *Phase II BPIP 032317 Summary File.txt*

Off Site Sources

The *ND Air Dispersion Modeling Guide* does not require the consideration of off-site sources when modeling for Significant Impact Levels (SIL) or Air Toxics.

3.3.3 Meteorological Data

Selection of Meteorological Observations

AERMET version 15181 was used to process five consecutive years of meteorological data for the period of 01/01/2009 to 12/31/2013 from the following stations:

24012 KDIK DICKINSON THEODORE ROOSEVELT R UNITED STATES NORTH DAKOTA
+46.799 -102.797 +786.4

24011 KBIS BISMARCK UNITED STATES NORTH DAKOTA
+46.774 -100.75 +506

Application of AERSURFACE to Process Land Surface Characteristics

The *AERSURFACE Input Recommendations* (09/16/2010) provided by the NDDoH were used in conjunction with AERSURFACE 13016 to generate the SURFACE and PROFILE files. The month to season assignment used was the Southwest North Dakota distribution.

The applicable and resulting files of the *AERSURFACE* program are listed below. Electronic copies of these files are provided with this report.

- *AERMET031717.SFC*
- *AERMET031717.PFL*
- *AERMET031717.MRG*

3.3.4 Receptor Locations

Primary Receptor Network

The refinery site will be fenced at the approximate property boundary to limit public access. As such, for modeling purposes it was modeled as a closed polygon. Per direction from NDDoH guidance, fence line receptors were set at 25 meter intervals along all boundaries. The datum for the receptor intervals was placed on the geometric mean of the site. Additional grid receptors were then spaced out per the distances below up to a maximum distance of approximately 23.85 km from the property boundaries (see Table 5).

**Table 5 – Non-Uniform Cartesian Grid, Distance and Interval Distribution
Davis Refinery Project, Billings County, ND**

| Sector | Distance (m) | Interval (m) |
|--------|--------------|--------------|
| 1 | 0-1500m | 100 |
| 2 | 1500-10000 | 250 |
| 3 | 10000-18500 | 500 |
| 4 | 18500-23850 | 1000 |

Additional Receptors Requested

Due to heightened public interest related to the proximity of the National Park, the NDDoH requested that additional receptors be placed in the model for the following key Park locations:

**Table 6 – Requested Additional Receptors
Davis Refinery Project, Billings County, ND**

| Receptor Name | X | Y | Elevation (m) |
|-------------------------------|----------|-----------|---------------|
| Painted Canyon Visitor Center | 623269.0 | 5194740.0 | 847.91 |
| Buckhill Trail Parking Area | 622580.0 | 5198267.0 | 851.56 |
| TRNP Amphitheater | 610813.0 | 5196768.0 | 763.33 |
| TRNP Visitor Center | 612373.0 | 5196908.0 | 691.23 |

Source: Additional Receptors.xlsx

While individual receptors for these points were established in the model, the highest modeled impacts within the Class I area were not identified in any instance as being close to these receptors and all levels at these receptor points were identified as being significantly below the applicable Class I SIL levels. Impact levels at these specific receptors are identified in the model output files.

Nearby Sources

Per NDDoH guidelines, no nearby sources were included in the preliminary modeling for comparison to SILs. Thus, no receptors associated with nearby sources are included.

Application of AERMAP

The model used NED data downloaded from the USGS Nation Map website to determine the elevation of the sources and receptors. The USGS returned a TIFF file bound by the following coordinates:

- North 46.628 N -103.25 E
- South 46.628 N -103.30 E
- West 46.876 N -103.61 E
- East 46.835 N -103.61 E

The elevation data extends 110 km by 93 km in the easterly and northerly directions, respectively. The proposed NDDR site and TRNP are within the boundaries of the downloaded elevation data. The extent of the region allows the variable receptor grid to extend 25 km from fence line of the site in the direction of each compass point. The data were processed with AERMAP version 11103 to extract the elevation of all sources and the park receptors, as well as their hill height scale.

3.3.5 Background Concentrations

Per NDDoH modeling guidelines, the background concentration of SO₂, NO₂, PM₁₀, PM_{2.5}, and CO were not applicable to the Significant Impact Level (SIL) analysis for the proposed facility.

3.4 AERMOD EXECUTION

A model analysis was run for each of the criteria pollutants that have a corresponding SIL value for both Class I and Class II areas. This was done for both the Primary (full production) Operating Scenario as well as the Alternative (Phase I = 27,500 bpd) Scenario. Electronic copies of all input and output files are provided to the NDDoH via computer disk and the list of all input and output names are shown in Attachment A of this report. The following options and assumptions were used in execution of the AERMOD model:

- Pollutant concentrations were calculated to match the frequencies of the SIL values listed in Table 1.
- Based on development on the adjacent properties and the planned use of the Project site area, the model was run using a rural option.

- Five years of representative meteorological integrated surface hourly data (ISHD) were used (2009 – 2013). Per the Dispersion Modeling Guidelines, the MAKEMET interface was utilized in AERMET for processing of meteorological data.
- It was assumed that 80% of NO_x is converted to NO₂
- Emissions rates were assumed constant.
- Emissions for all stack locations were modeled as point sources.
- Flare sources were modeled using AERMET flare source option in order to model as point sources.
- Building wake downwash was analyzed, as applicable, based on facility site designs using the BPIPFRM to automate the processing of terrain and building information.
- AERMOD was run using site specific terrain using AERMAP to process elevation data extracted from a NED07192016 Geo-TIF file.

3.5 INTERPRETATION OF AERMOD MODEL OUTPUT

Dispersion modeling to identify the potential near source impacts of the project was completed using the U.S. EPA's AERMOD dispersion model. This was done using pollutant emission rates and stack exit conditions for both Phase I and Phase II proposed operating conditions. These model results were compared to the NAAQS SILs provided in Table 1. Determination of compliance with the SILs within the established receptor grid was conducted for all criteria pollutants. Because the NAAQS SILs are met for both Class I and Class II areas, no further dispersion modeling should be required.

A summary of the highest modeled result for each of the SIL values is shown in Table 7a and 7b for both the primary and alternative operating scenarios, respectively. Identification of the location of each of the highest values for the Class I and Class II SIL comparisons is shown in Tables 8 and 9.

Table 7a – Summary of Modeled Highest Values Compared to NDDoH SILs ($\mu\text{g}/\text{m}^3$) – Primary Operating Scenario
Davis Refinery Project, Billings County, ND

| Pollutant | 1-Hour | | | | 3-Hour | | | | 8-Hour | | | | 24-Hour | | | | Annual | | | | | |
|-----------|---------|----------|---------|----------|---------|----------|----------|----------|---------|----------|---------|----------|----------|----------|---------|----------|----------|----------|---------|----------|----------|----------|
| | Limits | | Results | | Limits | | Results | | Limits | | Results | | Limits | | Results | | Limits | | Results | | | |
| | Class I | Class II | Class I | Class II | Class I | Class II | Class I | Class II | Class I | Class II | Class I | Class II | Class I | Class II | Class I | Class II | Class I | Class II | Class I | Class II | | |
| SO2 | - | 7.8 | - | 2.17 | 1.0 | 25 | 6.35E-01 | 1.06 | - | - | 0.2 | 5 | 1.42E-01 | 0.47 | 0.1 | 1 | 4.92E-03 | 2.75E-02 | 0.1 | 1 | 4.92E-03 | 2.75E-02 |
| NO2 | - | 7.5 | - | 7.10 | - | - | - | - | - | - | - | - | - | - | 0.1 | 1 | 2.54E-02 | 2.87E-01 | 0.1 | 1 | 2.54E-02 | 2.87E-01 |
| PM10 | - | - | - | - | - | - | - | - | - | 0.2 | 5 | 2.53E-02 | 6.35E-01 | - | 0.2 | 1 | 6.27E-03 | 6.35E-02 | 0.2 | 1 | 6.27E-03 | 6.35E-02 |
| PM2.5 | - | - | - | - | - | - | - | - | - | 0.07 | 1.2 | 4.69E-02 | 1.69E-01 | - | 0.06 | 0.3 | 2.49E-03 | 1.74E-02 | 0.06 | 0.3 | 2.49E-03 | 1.74E-02 |
| CO | - | 2000 | - | 2.17 | - | - | - | - | - | - | 500 | - | 0.65 | - | - | - | - | - | - | - | - | - |

Table 7b – Summary of Modeled Highest Values Compared to NDDoH SILs ($\mu\text{g}/\text{m}^3$) – Alternative Operating Scenario
Davis Refinery Project, Billings County, ND

| Pollutant | 1-Hour | | | | 3-Hour | | | | 8-Hour | | | | 24-Hour | | | | Annual | | | | | |
|-----------|---------|----------|---------|----------|---------|----------|----------|----------|---------|----------|---------|----------|----------|----------|---------|----------|----------|----------|---------|----------|----------|----------|
| | Limits | | Results | | Limits | | Results | | Limits | | Results | | Limits | | Results | | Limits | | Results | | | |
| | Class I | Class II | Class I | Class II | Class I | Class II | Class I | Class II | Class I | Class II | Class I | Class II | Class I | Class II | Class I | Class II | Class I | Class II | Class I | Class II | | |
| SO2 | - | 7.8 | - | 1.02E-01 | 1.0 | 25 | 2.64E-02 | 6.82E-02 | - | - | 0.2 | 5 | 8.14E-03 | 3.58E-02 | 0.1 | 1 | 4.53E-02 | 2.52E-03 | 0.1 | 1 | 4.53E-02 | 2.52E-03 |
| NO2 | - | 7.5 | - | 3.72 | - | - | - | - | - | - | - | - | - | - | 0.1 | 1 | 1.50E-02 | 1.27E-01 | 0.1 | 1 | 1.50E-02 | 1.27E-01 |
| PM10 | - | - | - | - | - | - | - | - | - | 0.2 | 5 | 6.32E-02 | 3.31E-01 | - | 0.2 | 1 | 2.21E-03 | 2.21E-02 | 0.2 | 1 | 2.21E-03 | 2.21E-02 |
| PM2.5 | - | - | - | - | - | - | - | - | - | 0.07 | 1.2 | 2.46E-02 | 1.68E-01 | - | 0.06 | 0.3 | 1.51E-03 | 1.74E-02 | 0.06 | 0.3 | 1.51E-03 | 1.74E-02 |
| CO | - | 2000 | - | 4.88 | - | - | - | - | - | - | 500 | - | 2.33 | - | - | - | - | - | - | - | - | - |

**Table 8a – Class I Areas PSD Increments and Significant Impact Levels
Primary Operating Scenario
Davis Refinery Project, Billings County, ND**

| Pollutant / Averaging Time | Significant Impact Level (µg/m³) | Modeled Result (µg/m³) | Receptor Location / Coordinate | |
|-------------------------------|-------------------------------------|---------------------------|--------------------------------|------------|
| | | | X | Y |
| PM ₁₀ ; Annual | 0.2 | 6.27E-03 | 627610.4 | 5195675.9 |
| PM ₁₀ ; 24 hour | 0.2 | 2.53E-02 | 622580 | 5198267 |
| PM _{2.5} ; Annual | 0.06 | 2.49E-03 | 627610.4 | 5195675.9 |
| PM _{2.5} ; 24 hour | 0.07 | 4.69E-02 | 627610.4 | 5195675.9 |
| SO ₂ ; Annual | 0.1 | 4.92E-03 | 627610.4 | 5195675.9 |
| SO ₂ ; 24 hour | 0.2 | 1.42E-01 | 620933.44 | 5195745.45 |
| SO ₂ ; 3 hour | 1.0 | 6.35E-01 | 627610.4 | 5195675.9 |
| NO ₂ ; Annual | 0.1 | 2.54E-02 | 627860.4 | 5195425.9 |

**Table 8b – Class I Areas PSD Increments and Significant Impact Levels
Alternative Operating Scenario
Davis Refinery Project, Billings County, ND**

| Pollutant / Averaging Time | Significant Impact Level (µg/m³) | Modeled Result (µg/m³) | Receptor Location / Coordinate | |
|-------------------------------|-------------------------------------|---------------------------|--------------------------------|------------|
| | | | X | Y |
| PM ₁₀ ; Annual | 0.2 | 2.21E-03 | 627610.4 | 5195675.9 |
| PM ₁₀ ; 24 hour | 0.2 | 6.32E-02 | 620933.44 | 5195745.45 |
| PM _{2.5} ; Annual | 0.06 | 1.51E-03 | 627610.4 | 5195675.9 |
| PM _{2.5} ; 24 hour | 0.07 | 2.46E-02 | 628110.4 | 5197675.9 |
| SO ₂ ; Annual | 0.1 | 4.53E-02 | 627610.4 | 5195675.9 |
| SO ₂ ; 24 hour | 0.2 | 8.14E-03 | 620933.4 | 5195745.5 |
| SO ₂ ; 3 hour | 1.0 | 2.64E-02 | 620933.4 | 5195745.5 |
| NO ₂ ; Annual | 0.1 | 1.50E-02 | 627610.4 | 5195675.9 |

Table 9a – Class II Areas PSD Increments and Significant Impact Levels
Primary Operating Scenario
Davis Refinery Project, Billings County, ND

| Pollutant / Averaging Time | Significant Impact Level ($\mu\text{g}/\text{m}^3$) | Modeled Result ($\mu\text{g}/\text{m}^3$) | Receptor Location / Coordinate | |
|-----------------------------|---|---|--------------------------------|-----------|
| | | | X | Y |
| PM ₁₀ ; Annual | 1.0 | 6.35E-02 | 634060.375 | 5193076 |
| PM ₁₀ ; 24 hour | 5.0 | 6.38E-01 | 633311.375 | 5192899 |
| PM _{2.5} ; Annual | 0.3 | 1.74E-02 | 634460.4 | 5192876.0 |
| PM _{2.5} ; 24 hour | 1.2 | 1.68E-01 | 634460.4 | 5192876.0 |
| SO ₂ ; Annual | 1.0 | 2.75E-02 | 634560.4 | 5192876.0 |
| SO ₂ ; 24 hour | 5.0 | 0.47 | 634460.4 | 5192876.0 |
| SO ₂ ; 3 hour | 25 | 1.06 | 627610.4 | 5193426.0 |
| SO ₂ ; 1 hour | 7.8 | 2.17 | 630960 | 5195676 |
| NO ₂ ; Annual | 1.0 | 2.87E-01 | 634060.375 | 5193076 |
| NO ₂ ; 1 hour | 7.5 | 7.10 | 630360.375 | 5192176 |
| CO; 8 hour | 500 | 0.65 | 634360.375 | 5193476 |
| CO; 1 hour | 2000 | 2.17 | 630960.375 | 5195676 |

Table 9b – Class II Areas PSD Increments and Significant Impact Levels
Alternative Operating Scenario
Davis Refinery Project, Billings County, ND

| Pollutant / Averaging Time | Significant Impact Level ($\mu\text{g}/\text{m}^3$) | Modeled Result ($\mu\text{g}/\text{m}^3$) | Receptor Location / Coordinate | |
|-----------------------------|---|---|--------------------------------|-----------|
| | | | X | Y |
| PM ₁₀ ; Annual | 1.0 | 2.21E-02 | 634060.375 | 5192876 |
| PM ₁₀ ; 24 hour | 5.0 | 3.31E-01 | 634060.375 | 5192876 |
| PM _{2.5} ; Annual | 0.3 | 1.28E-02 | 634060.4 | 5192976.0 |
| PM _{2.5} ; 24 hour | 1.2 | 1.39E-01 | 634060.4 | 5192876.0 |
| SO ₂ ; Annual | 1.0 | 2.52E-03 | 634060.4 | 5192976.0 |
| SO ₂ ; 24 hour | 5.0 | 3.55E-02 | 634060.4 | 5192876.0 |
| SO ₂ ; 3 hour | 25 | 6.82E-02 | 633372.1 | 5193743.0 |
| SO ₂ ; 1 hour | 7.8 | 1.02E-01 | 635260.4 | 5192976 |
| NO ₂ ; Annual | 1.0 | 1.27E-01 | 634060.4 | 5192976 |
| NO ₂ ; 1 hour | 7.5 | 3.72 | 627610.4 | 5193426 |
| CO; 8 hour | 500 | 2.33 | 633354.7 | 5193725.0 |
| CO; 1 hour | 2000 | 4.88 | 635260.4 | 5192976.0 |

4.0 AIR TOXICS ANALYSIS

4.1 INTRODUCTION

Zia conducted a Tier 3 analysis of Hazardous Air Pollutants (HAPs) as outlined in the NDDoH Policy for the Control of Hazardous Air Pollutant Emissions in North Dakota (Air Toxics Policy). This analysis yielded estimates of maximum off-property, ground-level ambient concentrations of HAP emissions from affected HAP sources. These values were then used to determine compliance with applicable Maximum Individual Carcinogenic Risk (MICR) assessments or 1-hour and 8-hour Guideline Concentrations (GCs), depending upon the HAP emission's known carcinogenicity, as well as the total aggregate Hazard Index and MICR for modeled HAP emissions.

Per the Air Toxics Policy, a Tier 3 analysis is not specifically required unless results show impacts above applicable Guideline Concentrations (GC) for non-carcinogenic HAPs or if results show impacts above MICR for HAPs with known carcinogenic health effects. However, because the Tier 3 approach is more conservative and refined than Tiers 1 and 2, and because modeling for compliance with SILs for Class I and Class II was required, a Tier 3 analysis was completed using BREEZE AERMOD modeling software.

4.2 COMPLIANCE DETERMINATION PROCEDURE

For HAPs with known or possible carcinogenic health effects (i.e., those HAPs for which a unit risk factor has been developed in Appendix B of the Air Toxics Policy), the MICR associated with emissions from the source was calculated as outlined in the Determination of Compliance section of the Air Toxics Policy. Similarly, the non-carcinogenic health effects of HAPs emitted from a source was evaluated by determining the hazard index for the HAPs for which a 1-hour GC or an 8-hour GC has been established in Appendix A of the Air Toxics Policy.

The following calculations have been performed:

1. Estimating the maximum 1-hour and 8-hour concentrations using the following formula:
 - Maximum 1-hour Concentration:
Total Modeled 1-hour Concentration (mg/m^3) \times Weight Percentage of each HAP
 - Maximum 8-hour Concentration:
Total Modeled 8-hour Concentration (mg/m^3) \times Weight Percentage of each HAP
2. Conducting the MICR analysis using the following equation:
 - $\text{MICR} = 1\text{-hour concentration } (\mu\text{g}/\text{m}^3) \times \text{Unit Risk Factor } (\text{m}^3/\mu\text{g})$

3. Determining the hazard index for HAPs for which a Guideline Concentration has been established in Appendix A of the Air Toxics Policy. For the HAPs which have both 1-hour and 8-hour GCs, the higher of the two ratios (MC/GC) was utilized in the following equation:
 - Hazard Index = $MC_1/GC_1 + MC_2/GC_2 + \dots + MC_n/GC_n$
 - Where MC_1, MC_2, \dots, MC_n are the modeled concentrations for HAPs 1, 2, ..., n and GC_1, GC_2, \dots, GC_n are Guideline Concentration for HAPs 1, 2, ..., n.

4.3 AIR TOXICS ANALYSIS RESULTS

The MICR for all HAPs emitted by point sources at the proposed new refinery, in aggregate, is 6.46×10^{-7} , which is less than the Air Toxics Policy threshold of 1.00×10^{-5} . Therefore, in consideration of MICR requirements set forth by the NDDH, the projected NDDR HAP emissions are in compliance.

The Hazard Index for HAPs emitted by point sources at the proposed new refinery, in aggregate, is 4.04×10^{-3} , which is less than the Air Toxics Policy threshold of 1.00 for a new source. Therefore, in consideration of Hazard Index requirements set forth by the NDDH, the projected NDDR HAP emissions are in compliance.

An aggregate MICR and an aggregate Hazard Index were assessed for individual, projected HAP emissions for the NDDR unit sources. These assessed values have been determined to be below the respective thresholds for each chemical category. Therefore, the proposed Davis Refinery is in compliance with the NDDH Air Toxics Policy. Associated calculations are provided in Attachment D.

5.0 PLUME VISIBILITY ANALYSIS

5.1 INTRODUCTION

The ND-DAQ requested a non-regulatory visibility study to determine if the cooling tower condensation plume rise from the proposed North Dakota Davis Refinery (NDDR) site would be visible at observation points at the Theodore Roosevelt National Park (TRNP). The proposed site for the NDDR is 5.5 km from the east boundary of the TRNP and some members of the public have expressed concern that the cooling tower condensation plume rise could affect the horizon visibility from the National Park. The results of the requested visibility report are provided for informational purposes only since there are no regulatory requirements for visibility analysis for a synthetic minor source facility.

The non-regulatory required visibility study considered four observation points located within the TRNP:

- The Amphitheater
- The TRNP Visitor Center
- Painted Canyon Visitor Center
- Buckhill Trail

5.2 VISIBILITY ANALYSIS PROCEDURE

The visibility study used the Seasonal/Annual Cooling Tower Impact Model, Version 2 (SACTI2), a mathematical model available from the Electric Power Research Institute. The model helps predict the direction, height, and frequency of the formation of a condensation plume from a cooling tower. The factors that affect the visibility of the plume are Meteorology, the rise of the condensation plume, the curvature of the earth, and the topography of the region.

5.3 SUMMARY OF VISIBILITY ANALYSIS RESULTS

The SACTI model and the factors suggest the Buckhill Trail will be the only observation point where the cooling tower plumes have the potential to be visible. The eastern horizon from the trail is 866 m above sea level (ASL) at a distance of 12.2 km from the proposed plant site. The SACTI model results indicate that the top portion (ΔH) of fifteen plumes might be visible above the horizon with the maximum visible height at 12.2 km being approximately 7.5 meters (see Table 10). It should be noted that at a distance of 12.2 km, it would be very hard to distinguish a height of 7.5 meters from the surrounding terrain. It should also be noted that there is no regulatory constraint related to plume visibility for the Class I area. A full summary and discussion of all visibility results is included in Attachment E of this Model Analysis.

**Table 10 – Visible Plumes Above the Buckhill Trail Horizon (Easterly Direction)
Davis Refinery Project, Billings County, ND**

| Height | ASL (m) | Delta H (m) |
|--------|---------|-------------|
| 53.5 | 873.5 | 7.5 |
| 53.3 | 873.3 | 7.3 |
| 51.1 | 871.1 | 5.1 |
| 50.8 | 870.8 | 4.8 |
| 50.7 | 870.7 | 4.7 |
| 50.0 | 870.0 | 4.0 |
| 49.9 | 869.9 | 3.9 |
| 49.8 | 869.8 | 3.8 |
| 49.6 | 869.6 | 3.6 |
| 49.6 | 869.6 | 3.6 |
| 49.6 | 869.6 | 3.6 |
| 49.5 | 869.5 | 3.5 |
| 48.8 | 868.8 | 2.8 |
| 48.6 | 868.6 | 2.6 |
| 46.2 | 866.2 | 0.2 |

ATTACHMENT A

Electronic Files Lists and Titles

(note: a separate CD has been provided to NDDoh of all Input and Output Files)

ATTACHMENT A
ELECTRONIC FILES LIST FOR MODELING AND ANALYSIS
DAVIS REFINERY PROJECT, BILLINGS COUNTY, ND

AERMET PROCESSED FILES

- AERMET031717.MRG
- AERMET031717.PFL
- AERMET031717.SFC
- NDDR031717.atz

Bismarck Upper Air Data

- KBIS24011FSL.FSL
- KBIS24011FSL.txt
- BIS24011-072016.txt
- BIS24011FSL.txt

BPIP

- Phase I BPIP 032117 Input File.txt
- Phase I BPIP 032117 Output File.txt
- Phase I BPIP 032117 Summary File.txt
- Phase II BPIP 032317 Input.txt
- Phase II BPIP 032317 Output.txt
- Phase II BPIP 032317 Summary File.txt

Dickinson Integrated Surface Hourly Data (ISHD)

- KDIK 24012.ISH
- KDIK 24012.txt

ELEVATION DATA

- 10012016.bhm
- 10012016.jpg
- NED07192016
- Ref.jgw
- Ref.jpg

Output Files**Phase I Files**

- SOX 1-hr Phase I 03-21-2017.txt
- SOX 3-hr Phase I 03-21-2017.txt
- SOX 24-hr Phase I 03-21-2017.txt
- SOX YR Phase I 03-21-2017.txt
- NO2 NAAQS 1-Hour Phase I 03-22-2017.tx
- NO2 YR Phase I 03-25-2017.txt
- PMTOT 24-hr Phase I 03-21-2017.txt
- PMTOT YR Phase I 03-21-2017.txt
- PM2.5 24-h Phase I 03-21-2017.txt
- PM2.5 YR Phase I 03-22-2017
- CO 1-hr Phase I 03-21-2017.txt
- CO 8-hr Phase I 03-21-2017.txt

Phase II Files

- SOX 1h Phase II 03232017PII 3-H.txt
- SOX 3h Phase II 03232017PII 1-H.txt
- SOX 24h Phase II 03232017.txt
- SOX YR Phase II 03232017PII ANNUAL.txt
- NO2 NAAQS 1-h Phase II 03232017PII ANNUAL.txt
- NO2 YR Phase II 03232017PII 1-H.txt
- PMTOT 24-h Phase II 03232017PM 10 PII ANNUAL.txt
- PMTOT YR Phase II 03232017PM 10 PII 24-H.txt
- PM25 24h Phase II 03232017PM 2.5 PII ANNUAL.txt
- PM25 YR Phase II 03232017PM 2.5 PII 24-H.txt
- CO 1-h Phase II 03232017.txt
- CO 8-h Phase II 03232017.txt

Phase I In/Out Model Files

CO Phase I

- Refinery Phase 1 03212017.ami
- Refinery Phase 1 03212017.amz

NO2 Phase I

- Refinery NOX YR Phase 1 03242017.ami
- Refinery NOX YR Phase 1 03242017.amz
- Refinery PM 2.5 Phase 1 03222017.ami
- Refinery PM 2.5 Phase 1 03222017.amz

PM 2.5 Phase I

- Refinery PM 2.5 Phase 1 03222017.ami
- Refinery PM 2.5 Phase 1 03222017.amz

PM 10 Phase I

- Refinery Phase 1 03212017.ami
- Refinery Phase 1 03212017.amz

SO2 Phase I

- Refinery Phase 1 03212017.ami

Refinery Phase 1 03212017.amz

Phase II In/Out Model Files

CO Phase II

- Refinery Phase II 03242017.ami
- Refinery Phase II 03242017.amz

NO2 Phase II

- Refinery II NO2 NAAQS 03232017.ami
- Refinery II NO2 NAAQS 03232017.amz
- Refinery Phase II 03242017.ami
- Refinery Phase II 03242017.amz

PM 2.5 Phase II

- Refinery Phase II 03242017.ami
- Refinery Phase II 03242017.amz

PM 10 Phase II

- Refinery Phase II 03242017.ami
- Refinery Phase II 03242017.amz

SO2 Phase II

- Refinery Phase II 03242017.ami
- Refinery Phase II 03242017.amz

Air Toxics Analysis

- Tier 3 Analysis.xlsx
- Air Toxics Analysis.xlsx

ATTACHMENT B

Air Quality Dispersion Analysis Guide

North Dakota Department of Health, Division of Air Quality
Air Quality Dispersion Modeling Analysis Guide
June 21, 2013

The following Air Quality Modeling Analysis Guide is provided by the North Dakota Department of Health (Department) to aid air permit applicants in the process of developing an air dispersion modeling protocol and in conducting an air dispersion modeling analysis. This general Guide outlines common topics that should be addressed in a dispersion modeling analysis and report for projects located in North Dakota. As each project is unique, the Guide should not be considered “all inclusive” and some important items for a given project may not be reflected in the itemized list below. The Department should be consulted at an early stage in the project to assure that essential items are addressed in any final modeling analysis.

The Department strongly encourages the development of a pre-application dispersion modeling protocol in consultation with the Department in order to expedite the ultimate project review process. This Guide will aid in the development of that protocol.

A list of applicable State issued modeling guidance documents covering specific issues is included at the end of this Guide. Note that these documents include criteria to determine whether modeling will be required for a permit-related project. Also included is guidance related to air toxics analyses. Please contact the Department with any project-specific questions or concerns by calling 701.328.5188.

To the extent applicable, the information in this Guide is consistent with the EPA Guideline on Air Quality Models¹. The Department Guide is intended to clarify EPA Guidance for applicability to North Dakota regulatory projects, and to supplement EPA guidance on issues where guidance is not specifically provided. This Guide assumes basic familiarity with regulatory air quality modeling applications on the part of the reader.

It is expected that the information contained in this Guide will be updated frequently, so the Department’s Web site² should be actively monitored for the most recent version. At this time, the Guide applies primarily to local scale modeling analyses for NAAQS, PSD Class II increments, and air toxics thresholds. Future updates to this Guide or supplemental documents will include modeling guidance for Class I PSD increments and air quality related values (AQRVs). If you anticipate that your project will need to address one of these two conditions or any other item not specifically covered by the Guide at this time, please consult with the Department directly for further information and guidance.

¹ CFR, 2005. EPA Guideline on Air Quality Models. 40 CFR (Code of Federal Regulations) Part 51, Appendix W.

² <http://www.ndhealth.gov/AQ/DispersionModeling.htm>

I. Modeling for NAAQS, NDAAQS, PSD Class II increments, Air Toxics thresholds

A. Screening Analyses (optional for isolated single source)

1. Model selection:

- AERSCREEN – applicable if significant terrain height variations involved. Because of the relative complexity (for a screening tool) involved in executing and reviewing AERSCREEN analyses, the NDDH discourages the use and submittal of AERSCREEN screening techniques for projects in North Dakota. Direct application of refined modeling using AERMOD is recommended if significant terrain height variations are associated with an isolated single source.
- SCREEN3 – applicable only in relatively level terrain.

2. Model input/execution:

- AERSCREEN – Refer to AERSCREEN User's Guide for information on input data and execution for AERMOD. As noted above, the NDDH discourages the use of AERSCREEN for projects in North Dakota.
- SCREEN3 - Command line program which prompts user for all necessary input data (EPA version).

B. Refined Analyses (SIL and cumulative)

1. Model selection:

- AERMOD (provide version number)

2. Emission inventory:

- Subject source
 - Point source fixed stack characteristics for each emission unit:
 - Location (e.g., UTM coordinates)
 - Stack height
 - Stack base elevation (above MSL)

June 21, 2013

North Dakota Department of Health
Air Quality Dispersion Modeling Analysis Guide

Page 3 of 12

- Stack exit diameter
- Stack orientation (e.g., vertical up, vertical down, horizontal, rain caps, etc.)
- Point source variable stack characteristics for each emission unit. Ensure that worst case emission scenarios are accounted for (i.e., consider multiple operating loads, start-up, shut-down) For combustion turbines, where emissions are particularly sensitive to ambient temperature, emission scenarios should also account for a range of ambient temperatures.
 - Emission rate for each applicable pollutant species
 - Stack exit velocity
 - Stack exit temperature
- Appropriate adjustment of stack exit velocity based on stack orientation (See AERMOD Implementation Guide³)
- Appropriate determination of point source stack characteristics for flares (See Flare Guidance). Stack characteristics which are adjusted for flares include stack height, stack diameter, exit velocity, and exit temperature.
- Area source characteristics for each emission unit (if any):
 - Emission rate for each applicable pollutant species
 - Boundary of area
 - Effective height of area emissions
- Volume source characteristics for each emission unit (if any):
 - Emission rate for each applicable pollutant species
 - Effective dimensions
 - Height of center of volume source
 - The NDDH does not require inclusion of paved road fugitive emissions in modeling analyses.
- Building downwash characteristics for each affected (less than GEP height) point-source stack, developed using the EPA BPIPPRM program (include a plant layout drawing):
 - Building height for 36 wind directions
 - Effective building width for 36 wind directions
 - Building length for 36 wind directions
 - X offset for 36 wind directions (XBADJ)
 - Y offset for 36 wind directions (YBADJ)

³ EPA, 2009. AERMOD Implementation Guide: March 19, 2009. Accessed at: http://www.epa.gov/scram001/7thconf/aermod/aermod_implmntn_guide_19March2009.pdf. June 20, 2013

- Off-site (nearby) sources (not applicable for SILs or Air Toxics analyses). For PSD projects, the impact of emissions from all sources located within 50 km of the subject source should generally be included in the modeling analysis. For non-PSD projects, the impact of emissions from all sources located within 20 km of the subject source should generally be included in the modeling analysis. Impact from sources not explicitly modeled will be accounted for with the background concentration(s).
- Point source stack characteristics for each nearby-source unit:
 - Emission rate for each applicable pollutant species. Emission rate should reflect maximum allowable (permitted). For PSD increment analyses, or if maximum allowable not available for AAQS analyses, actual emission rate may be used.
 - Location (e.g., UTM coordinates)
 - Stack height
 - Stack base elevation (above MSL)
 - Stack exit diameter
 - Stack exit velocity
 - Stack exit temperature
 - Stack orientation (e.g., vertical up, vertical down, horizontal, rain caps, etc.)
- Appropriate adjustment of stack exit velocity based on stack orientation (See See AERMOD Implementation Guide⁴)
- Appropriate determination of point source stack characteristics for flares (See Flare Guidance). Stack characteristics which are adjusted for flares include stack height, stack diameter, exit velocity, and exit temperature.
- The NDDH should be consulted regarding the need for including building downwash effects for nearby sources.

NOTE: Stack characteristics for nearby sources can typically be obtained from the Department. Please contact the Department for more information.

3. Meteorological data:

- Selection of meteorological observations:
 - Five consecutive years of recent representative National Weather Service (NWS) hourly surface observations (identify station).

⁴ EPA, 2009. AERMOD Implementation Guide: March 19, 2009. Accessed at: http://www.epa.gov/scram001/7thconf/aermod/aermod_implmntn_guide_19March2009.pdf. June 20, 2013

- Five concurrent years of NWS twice-daily upper-air observations (identify station).
- Surface observations from non-NWS sites may be considered as an option (e.g., on-site, Department monitoring sites), but the Department should be contacted regarding the availability and acceptability of such data, as well as pairing such data with NWS upper-air observations.
- Application of AERSURFACE (specify version number) to process land surface characteristics for use with AERMET. (See Department guidance for AERSURFACE input settings.)
- Application of AERMET (specify version number) to process surface observations, upper-air observations, and AERSURFACE output in order to create the SURFACE and PROFILE files required by AERMOD.

NOTE: AERMET-compatible surface and upper-air five-year meteorological data sets for a number of NWS stations located in and near North Dakota are available via the Department's FTP site⁵.

4. Receptor locations:

- Specify primary receptor network (a case-by-case determination will likely be required, but the following is a typical configuration for medium-buoyancy sources):
 - Receptors spaced at 25 m along the limited access (fenced) boundary (ambient air boundary). If access is not limited, receptor coverage must include entire property area.
 - Nested Cartesian receptor grids outside of the fenced boundary. Resolution of nested receptor grids should proceed in a geometric pattern, e.g., 50 m for the inner grid, 100 m for the next grid, 250 m for the next grid, and 500 m for the outside grid. The maximum extent of the outside grid will depend on the buoyancy (plume height) of the source. Generally, a grid extending out to 10 km from the source will be adequate for a medium-buoyancy source.
- In addition to the primary network, additional receptors may be needed to address isolated terrain features, impact from low-level sources located near the facility fence line, and to refine predictions when the maximum modeled impact occurs at a receptor located in a relatively coarse portion of the primary receptor network.
- If the analysis includes nearby sources, the Department may request that additional receptors are placed to account for the maximum combined impact of the subject source and the nearby source.

⁵ <ftp://ftp.state.nd.us/AirQuality/AERMOD/>

- Obtain digital elevation data (e.g., NED) for the modeling domain.
 - Application of AERMAP (specify version number) to receptor locations and digital elevation data in order to determine receptor elevation and hill-height scale needed for AERMOD.
 - Provide map showing receptor locations and elevation with respect to source location(s).
5. Background concentrations (account for contribution of natural and non-modeled anthropogenic sources, not applicable for SILs or Air Toxics analyses):
- Fixed background concentrations for SO₂, NO₂, PM₁₀, PM_{2.5}, and CO (all averaging times) are provided in Table 1. These fixed background levels reflect default values which are representative for the entire State of North Dakota. The Department should be contacted regarding representativeness and current status of these values for a particular modeling project.
 - Variable (hourly) background concentration files for SO₂ and NO₂ are available for several locations on the Department's FTP site⁶. These hourly background files cover a five-year period and are concurrent with the meteorological data sets also provided on the FTP site.
 - Hourly ozone background concentration files are also provided on the Department's FTP site for several locations. These ozone data sets are provided to implement the Ozone Limiting Method (OLM) for NO₂ Tier 3 analysis.

NOTE: The use of hourly background concentration data for SO₂ and NO₂, if representative data are available for the project location, will produce the least conservative results when added to model output (i.e., less conservative than use of fixed background concentrations).

Table 1
Fixed Background Concentrations for North Dakota
(µg/m³)

| Pollutant | Averaging Period | | | | |
|-------------------|------------------|--------|--------|---------|--------|
| | 1-hour | 3-hour | 8-hour | 24-hour | Annual |
| SO ₂ | 13 | 11 | --- | 9 | 3 |
| NO ₂ | 35 | --- | --- | --- | 5 |
| PM ₁₀ | --- | --- | --- | 30 | 15 |
| PM _{2.5} | --- | --- | --- | 13.7 | 4.75 |
| CO | 1149 | --- | 1149 | --- | --- |

⁶ <ftp://ftp.state.nd.us/AirQuality/AERMOD/>

6. AERMOD execution:

- Execute AERMOD for emission inventory, meteorological data, receptor locations, and with background concentrations, as outlined above:
 - Use regulatory default option.
 - Specify rural source (urban may be appropriate in rare cases).
 - Use appropriate options for processing form of new 1-hour NAAQS for SO₂ and NO₂, and 24-hour NAAQS for PM₁₀ and PM_{2.5}.
 - Use proper settings to implement Tier 3 NO₂ analysis (if applicable):
 - The Department prefers the OLM option to PVMRM.
 - With OLM, use setting “OLMGROUP ALL”.
 - Use hourly ozone background data file (above).
 - Contact vendor and Department for appropriate in-stack ratios of NO₂ to NO_x. Use of a default value of 0.5 is acceptable without justification.
 - Note that EPA approval is needed regarding protocol for Tier 3 NO₂ analysis.
 - Add background concentrations to model results (not applicable for SILs or Air Toxics analyses, and generally not applicable for PSD increment analyses).

7. Interpretation of model output:

- Comparison of results with acceptable air quality thresholds:
 - Significant impact levels (see Table 2)
 - NAAQS/NDAAQS (see Table 3)
 - PSD Class II increments (see Table 4)
 - Air Toxics thresholds (MICR and Hazard Index, see State Air Toxics Policy)
- Provide receptor location of maximum impact for each species and averaging times. Location of maximum impact should be subsequent to processing the form of the NAAQS (e.g., 5-year average of annual 99th percentile of daily maximum 1-hour average concentration for SO₂).

8. Submittal of modeling report:

- A modeling report, including a detailed description of all input data, model execution, and results, should be prepared and provided with the permit application.
- All computer modeling files should be submitted along with the modeling report.
- An electronic copy of the modeling report should be submitted along with at least three hard copies. Electronic submittal should include both PDF and MS Word (or other native) versions.

**Table 2
Class II Area Significant Impact Levels
($\mu\text{g}/\text{m}^3$)**

| Pollutant | Averaging Period | | | | |
|-------------------|------------------|--------|--------|---------|--------|
| | 1-hour | 3-hour | 8-hour | 24-hour | Annual |
| SO ₂ | 7.8 | 25 | --- | 5 | 1 |
| NO ₂ | 7.5 | --- | --- | --- | 1 |
| PM ₁₀ | --- | --- | --- | 5 | 1 |
| PM _{2.5} | --- | --- | --- | 1.2 | 0.3 |
| CO | 2000 | --- | 500 | --- | --- |

Table 3
North Dakota and National Ambient Air Quality Standards (AAQS)
Criteria Pollutants ($\mu\text{g}/\text{m}^3$)

| Pollutant | Averaging Period | N.D. AAQS | National AAQS |
|--|------------------|---------------------|---------------------|
| Sulfur Dioxide (SO_2) | 1-hour | 196 ² | 196 ² |
| | 3-hour | 1309 ¹ | 1309 ¹ |
| | 24-hour | --- | 365 ¹ |
| | Annual | --- | 80 |
| Nitrogen Dioxide (NO_2) | 1-hour | 188 ³ | 188 ³ |
| | Annual | 100 | 100 |
| Inhalable Particulate (PM_{10}) | 24-hour | 150 ¹ | 150 ¹ |
| Particulate ($\text{PM}_{2.5}$) | 24-hour | 35 ⁴ | 35 ⁴ |
| | Annual | 15 ⁵ | 12 ⁵ |
| Carbon Monoxide (CO) | 1-hour | 40,000 ¹ | 40,000 ¹ |
| | 8-hour | 10,000 ¹ | 10,000 ¹ |
| Lead (Pb) | Quarterly | 1.5 | 1.5 |

¹ One exceedance per year is permitted.

² Based on 3-year average of annual 99th percentile (4th highest) of daily maximum 1-hour average concentration.

³ Based on 3-year average of annual 98th percentile (8th highest) of daily maximum 1-hour average concentration.

⁴ Based on 3-year average of annual 98th percentile 24-hour concentration.

⁵ Based on 3-year average of annual average concentrations.

Table 4
North Dakota / National Prevention of Significant Deterioration (PSD) Increments
Criteria Pollutants ($\mu\text{g}/\text{m}^3$)

| Pollutant | Averaging Period | Class I | Class II | Class III |
|------------------------------------|------------------|-----------------|------------------|------------------|
| Sulfur Dioxide (SO_2) | 3-hour | 25 ¹ | 512 ¹ | 700 ¹ |
| | 24-hour | 5 ¹ | 91 ¹ | 182 ¹ |
| | Annual | 2 | 20 | 40 |
| Nitrogen Dioxide (NO_2) | Annual | 2.5 | 25 | 50 |
| Particulate (PM_{10}) | 24-hour | 8 ¹ | 30 ¹ | 60 ¹ |
| | Annual | 4 | 17 | 34 |
| Particulate ($\text{PM}_{2.5}$) | 24-hour | 2 ¹ | 9 ¹ | 18 ¹ |
| | Annual | 1 | 4 | 8 |

¹ One exceedance per year is permitted.

II. Guidance Documents

The North Department has developed the following guidance and policy documents to assist permit applicants in the process of drafting complete permit applications.

The first three documents referenced below can be accessed via the links posted under the document title. The remainder of the documents can be found on the Department's FTP site under "Guidance and Policy Documents".

To request access to the FTP site, or for more information on Dispersion Modeling, please direct questions or comments to the North Dakota Department of Health at 701.328.5188.

Intradepartmental Memorandum - Criteria Pollutant Modeling Requirements for a Permit to Construct: September 12, 2006

http://www.ndhealth.gov/AQ/AirPermitting_files/Modeling%20Memo.pdf

The Department has developed a set of guidelines to determine what modeling requirements apply to a facility as part of the application for a Permit to Construct (PTC). This document outlines the requirements for projects subject to the Prevention of Significant Deterioration of Air Quality (PSD) rules and for projects not subject to PSD; and also includes additional information applicable to all projects (both PSD and non-PSD).

Policy for the Control of Hazardous Air Pollutant Emissions in North Dakota (Air Toxics Policy): August 25, 2010

<http://www.ndhealth.gov/AQ/Toxics/North%20Dakota%20Air%20Toxics%20Policy.pdf>

This document establishes the policy for the evaluation of sources emitting Hazardous Air Pollutants (HAPs) into the ambient air. It includes a description of the three-tiered approach to calculating the maximum off-property ground-level ambient concentration of each HAP.

June 21, 2013

Page 11 of 12

Dispersion Modeling Requirements, Compressor Engines and Glycol Dehydration Units

May 16, 2011

http://www.ndhealth.gov/AQ/AirPermitting_files/Compressor%20Engine%20&%20Dehydrator%20Policy.pdf

This document clarifies when dispersion modeling is required to be submitted for facilities which include compressor engine(s) and/or glycol dehydration unit(s) as the primary source(s) of emissions. Both criteria pollutants and hazardous air pollutants (air toxics) are addressed.

Model Input Parameters for Flares

November 10, 2010

Flare Plume Rise.pdf

This document outlines the Department recommended approach for developing the model input parameters of stack temperature, diameter, exit velocity, and stack height to allow a given refined air quality model (e.g. AERMOD, ISC-PRIME) to accurately calculate a buoyancy representative of the conditions above the flare.

Recommended AERSURFACE Inputs (North Dakota)

September 16, 2010

AERSURFACE Inputs.pdf

This document provides Department recommended inputs for AERSURFACE, a surface land cover characteristics preprocessor for AERMOD, appropriate for modeling in North Dakota.

User's Instructions for HRLYNAAQS.

September 24, 2010

HRLYNAAQS User's Guide.pdf

The software program HRLYNAAQS is provided by the Department (on request) to assist permit applicants and consultants in the demonstration of modeled compliance with the new 1-hour National Ambient Air Quality Standards (NAAQS) for NO₂ and SO₂. HRLYNAAQS provides the annual 98th (NO₂) or 99th (SO₂) percentile of maximum daily 1-hour concentrations averaged across five years, for each receptor location. Along with the total concentration, HRLYNAAQS also provides individual contributions for up to five source groups.

June 21, 2013

North Dakota Department of Health
Air Quality Dispersion Modeling Analysis Guide

Page 12 of 12

AERMET Surface Meteorology Stations (2004-2008)

AERMET Upper-Air Meteorology Stations (2004-2008)

Met Stations 2004-2008 WBAN.pdf

This document provides the locations of surface and upper-air meteorology stations in North Dakota for which meteorological data suitable for use with AERMET is provided by the Department (available on request).

Hourly Ozone Sites (2004-2008)

Ozone Sites 2004-2008.pdf

This document provides the locations within North Dakota of hourly ozone ambient monitoring sites as well as information on the formatting of the hourly ozone source data files (available on request).

ATTACHMENT C

Emissions Sources Characteristics

Air Modeling Input Data - Primary Operating Scenario Source Characteristics
Davis Refinery, Billings County, North Dakota

| ID | Description | X Coordinate | Y Coordinate | Elevation (m) | Stack H | Stack Temp (F) | Stack V (ft/s) | Stack Diam (ft) | CO (lb/h) | Pb (lb/h) | PW (lb/h) | PMCOND (lb/h) | PM2.5 (lb/h) | NOX (lb/h) | SOX (lb/h) | VOC (lb/h) | NO2 (lb/h) | HAP (lb/h) | |
|----------|-------------------------------------|-----------------|-----------------|------------------|----------|-------------------|-------------------|--------------------|-----------|-----------|------------|------------------|--------------|------------|------------|------------|------------|------------|--------|
| 101H0101 | 101H0101 ADU #1 HEATER | 633521.33 | 5193257.56 | 807.91 | 127.6 | 790.2 | 22.8 | 6.3 | 2.3 | 4.02E-05 | 0.329 | 0.246 | 0.08210003 | 0.517 | 0.0483 | 0.443 | 0.414 | 0.0408 | |
| 102H0201 | 102H0201 ADU #2 HEATER | 633644.74 | 5193281.83 | 805.98 | 127.6 | 790.2 | 22.8 | 6.3 | 2.3 | 4.02E-05 | 0.329 | 0.246 | 0.08210003 | 0.517 | 0.0483 | 0.443 | 0.414 | 0.0408 | |
| 103H0301 | 103H0301 Vacuum Heater 1 | 633764.53 | 5193252.29 | 804.39 | 125 | 790.2 | 19.5 | 6.5 | 2.1 | 3.68E-05 | 0.3 | 0.225 | 0.075 | 0.473 | 0.0441 | 0.404 | 0.378 | 0.0372 | |
| 112H1201 | 112H1201 Reactor Feed Heater | 633796.32 | 5193476.12 | 803.02 | 100 | 790 | 25.5 | 4 | 1.04 | 1.82E-05 | 0.149 | 0.111 | 0.0372 | 0.234 | 0.0219 | 0.2 | 0.187 | 0.0184 | |
| 112H1202 | 112H1202 Fractionator Feed Heater | 633753.83 | 5193471.18 | 803.66 | 100 | 790.4 | 27.7 | 4 | 1.13 | 1.98E-05 | 0.161 | 0.121 | 0.0403 | 0.254 | 0.0237 | 0.218 | 0.203 | 0.02 | |
| 105H0501 | 105H0501 Reactor Feed | 633574.74 | 5193331.84 | 806.37 | 91 | 790.2 | 16.2 | 2.4 | 0.241 | 4.21E-06 | 0.0344 | 0.0258 | 0.0086 | 0.258 | 0.00506 | 0.0464 | 0.206 | 0.00427 | |
| 105H0502 | 105H0502 Stabilizer Reboiler | 633574.11 | 5193350.12 | 806.72 | 91 | 790.2 | 19.1 | 2.3 | 0.26 | 4.56E-06 | 0.0372 | 0.0279 | 0.0093 | 0.279 | 0.00547 | 0.0501 | 0.223 | 0.00461 | |
| 105H0503 | 105H0503 Splitter Reboiler | 633573.48 | 5193368.39 | 807.04 | 105 | 790.2 | 16.1 | 3.5 | 0.501 | 8.77E-06 | 0.0716 | 0.0537 | 0.0179 | 0.537 | 0.0105 | 0.09650003 | 0.43 | 0.00888 | |
| 110H1001 | 110H1001 Reactors Heater | 633624.41 | 5193350.52 | 805.31 | 96 | 790.2 | 28.4 | 2.8 | 0.546 | 9.56E-06 | 0.07799999 | 0.0585 | 0.0195 | 0.585 | 0.0115 | 0.105 | 0.468 | 0.00968 | |
| 110H1002 | 110H1002 Splitter | 633623.53 | 5193376.01 | 805.57 | 91 | 790.2 | 24.5 | 3.5 | 0.764 | 1.34E-05 | 0.109 | 0.08190002 | 0.0273 | 0.8190002 | 0.0161 | 0.147 | 0.655 | 0.0135 | |
| 106H0601 | 106H0601 Reactor Heater | 633573.39 | 5193541.65 | 807.92 | 130 | 790.2 | 27.2 | 7.4 | 3.83 | 6.71E-05 | 0.548 | 0.411 | 0.137 | 0.8520002 | 0.0805 | 0.738 | 0.6900001 | 0.0679 | |
| 106H0605 | 106H0605 Stabilizer Reboiler | 633552.02 | 5193540.18 | 808.41 | 42 | 790.2 | 15.7 | 2 | 0.16 | 2.79E-06 | 0.0228 | 0.0171 | 0.0057 | 0.171 | 0.00335 | 0.0307 | 0.137 | 0.00283 | |
| B0202A | B0202A High Pressure Steam Boiler 1 | 633421.93 | 5193187.95 | 810.94 | 100 | 300.4 | 34.6 | 2 | 0.616 | 1.08E-05 | 0.08799997 | 0.06559998 | 0.022 | 0.66 | 0.0129 | 0.119 | 0.5279999 | 0.0109 | |
| B0202B | B0202B High Pressure Steam Boiler 2 | 633421.51 | 5193200.14 | 810.74 | 100 | 300.4 | 34.6 | 2 | 0.616 | 1.08E-05 | 0.08799997 | 0.06559998 | 0.022 | 0.66 | 0.0129 | 0.119 | 0.5279999 | 0.0109 | |
| B0201A | B0201A Medium Pressure Steam Boiler | 633422.13 | 5193180.84 | 811.04 | 100 | 300.5001 | 26.5 | 1.7 | 0.327 | 5.72E-06 | 0.0467 | 0.035 | 0.0117 | 0.35 | 0.00687 | 0.063 | 0.28 | 0.0058 | |
| B0201B | B0201B Medium Pressure Steam Boiler | 633422.13 | 5193180.84 | 811.04 | 100 | 300.5001 | 26.5 | 1.7 | 0.327 | 5.72E-06 | 0.0467 | 0.035 | 0.0117 | 0.35 | 0.00687 | 0.063 | 0.28 | 0.0058 | |
| B0201C | B0201C Medium Pressure Steam Boiler | 633422.13 | 5193180.84 | 811.04 | 100 | 300.5001 | 26.5 | 1.7 | 0.327 | 5.72E-06 | 0.0467 | 0.035 | 0.0117 | 0.35 | 0.00687 | 0.063 | 0.28 | 0.0058 | |
| CT1501A | CT1501A Cooling Tower Cell A | 633385.33 | 5193142.32 | 812.95 | 70.01312 | 84.992 | 4.966876 | 35.98999 | 0 | 0 | 0.118 | 0 | 0 | 0 | 0 | 0.09 | 0 | 0 | |
| CT1501B | CT1501B Cooling Tower Cell B | 633389.57 | 5193142.46 | 812.78 | 70.01312 | 84.992 | 4.966876 | 35.98999 | 0 | 0 | 0.118 | 0 | 0 | 0 | 0 | 0.09 | 0 | 0 | |
| CT1501C | CT1501C Cooling Tower Cell C | 633393.82 | 5193142.61 | 812.64 | 70.01312 | 84.992 | 4.966876 | 35.98999 | 0 | 0 | 0.118 | 0 | 0 | 0 | 0 | 0.09 | 0 | 0 | |
| CT1501D | CT1501D Cooling Tower Cell D | 633398.05 | 5193142.76 | 812.51 | 70.01312 | 84.992 | 4.966876 | 35.98999 | 0 | 0 | 0.118 | 0 | 0 | 0 | 0 | 0.09 | 0 | 0 | |
| CT1501E | CT1501E Cooling Tower Cell E | 633402.31 | 5193142.91 | 812.37 | 70.01312 | 84.992 | 4.966876 | 35.98999 | 0 | 0 | 0.118 | 0 | 0 | 0 | 0 | 0.09 | 0 | 0 | |
| FL701 | FL701 HC Enclosed Flare Pilots | 633610.63 | 5193648.53 | 808.9 | 58.61001 | 1000 | 40 | 2.5 | 0.034 | 0 | 0.005 | 0 | 0.00122 | 0.007 | 0.004 | 0.0066 | 0.0066 | 0 | |
| FL702 | FL702 Acid Flare Pilots | 633596.26 | 5193721.25 | 808.64 | 154.31 | 1000 | 40 | 0.375 | 0.006 | 0 | 0.001 | 0 | 0.000204 | 0.001 | 0.001 | 0.0011 | 0.0008 | 0 | |
| FL703 | FL703 HC Emergency Flare Pilots | 633599.3 | 5193721.35 | 808.68 | 154.4 | 1000 | 40 | 1.3 | 0.009 | 0 | 0.001 | 0 | 0.000306 | 0.002 | 0.001 | 0.00165 | 0.0016 | 0 | |
| FL704 | FL704 HC Emergency Flare Pilots | 633719.61 | 5193725.52 | 806.33 | 154.4 | 1000 | 40 | 1.3 | 0.009 | 0 | 0.001 | 0 | 0.000306 | 0.002 | 0.001 | 0.00165 | 0.0016 | 0 | |
| REFORM | Reformer | 633555.19 | 5193525.63 | 808.26 | 42 | 790.2 | 15.7 | 2 | 0 | 0 | 0 | 0 | 0 | 0 | 0 | 0 | 0.706 | 0 | 0.0681 |
| SRU | SRU | 633616.95 | 5193525.47 | 806.75 | 60 | 414.5 | 50 | 1.7 | 2.36 | 0 | 0 | 0 | 0 | 0.52 | 0.22 | 1.65 | 0.414 | 0 | |

Air Modeling Input Data - Alternative Operating Scenario Source Characteristics
Davis Refinery, Billings County, North Dakota

| ID | Description | X Coordinate | Y Coordinate | Elevation (m) | Stack H | Stack Temp (°F) | Stack V (ft/s) | Stack Diam (ft) | CO (lb/h) | Pb (lb/h) | PM (lb/h) | PMCOND (lb/h) | PM2.5 (lb/h) | NOX (lb/h) | SOX (lb/h) | VOC (lb/h) | NO2 (lb/h) | HAP (lb/h) | |
|----------|---------------------------------------|--------------|--------------|---------------|----------|-----------------|----------------|-----------------|-----------|-----------|------------|---------------|--------------|------------|------------|-------------|------------|------------|---------|
| 101H0101 | 10TH0101 ADU #1 HEATER | 633521.38 | 5193257.56 | 807.91 | 127.6 | 790.2 | 22.8 | 6.3 | 2.2966 | 4.02E-05 | 0.3285 | 0.2464 | 0.08210003 | 0.5174 | 0.0483 | 0.4429 | 0.414 | 0.0408 | |
| 102H0201 | 102H0201 ADU #2 HEATER | 633644.74 | 5193261.83 | 805.98 | 127.6 | 790.2 | 22.8 | 6.3 | 0 | 0 | 0 | 0 | 0 | 0 | 0 | 0 | 0 | 0 | 0 |
| 103H0301 | 103H0301 Vacuum Heater 1 | 633764.36 | 5193252.29 | 804.39 | 125 | 790.2 | 19.5 | 6.5 | 0 | 0 | 0 | 0 | 0 | 0 | 0 | 0 | 0 | 0 | 0 |
| 112H1201 | 112H1201 Reactor Feed Heater | 633796.32 | 5193476.12 | 803.02 | 100 | 790 | 25.5 | 4 | 0 | 0 | 0 | 0 | 0 | 0 | 0 | 0 | 0 | 0 | 0 |
| 112H1202 | 112H1202 Fractionator Feed Heater | 633753.88 | 5193471.18 | 803.66 | 100 | 790.4 | 27.1 | 4 | 0 | 0 | 0 | 0 | 0 | 0 | 0 | 0 | 0 | 0 | 0 |
| 105H0501 | 105H0501 Reactor Feed | 633574.74 | 5193351.84 | 806.37 | 91 | 790.2 | 16.2 | 2.4 | 0.1634 | 2.11E-06 | 0.0172 | 0.0128 | 0.0043 | 0.129 | 0.0025 | 0.0232 | 0.103 | 0.0021 | |
| 105H0502 | 105H0502 Stabilizer Reboiler | 633574.11 | 5193350.12 | 806.72 | 91 | 790.2 | 19.1 | 2.3 | 0.2204 | 2.84E-06 | 0.0232 | 0.0174 | 0.0058 | 0.174 | 0.0034 | 0.0313 | 0.139 | 0.0029 | |
| 106H0503 | 106H0503 Splitter Reboiler | 633573.48 | 5193368.39 | 807.04 | 105 | 790.2 | 16.1 | 3.5 | 0.4256 | 5.49E-06 | 0.04800011 | 0.0336 | 0.0112 | 0.336 | 0.0066 | 0.060400011 | 0.269 | 0.0056 | |
| 110H1001 | 110H1001 Reactors Heater | 633624.41 | 5193360.52 | 805.31 | 96 | 790.2 | 28.4 | 2.8 | 0.3724 | 4.80E-06 | 0.0392 | 0.0294 | 0.0098 | 0.294 | 0.0058 | 0.0528 | 0.235 | 0.0049 | |
| 110H1002 | 110H1002 Splitter | 633623.53 | 5193376.01 | 805.57 | 91 | 790.2 | 24.5 | 3.5 | 0 | 0 | 0 | 0 | 0 | 0 | 0 | 0 | 0 | 0 | |
| 106H0601 | 106H0601 Reactor Heater | 633573.39 | 5193541.65 | 807.92 | 130 | 790.2 | 27.2 | 7.4 | 1.5504 | 2.00E-05 | 0.1632 | 0.1224 | 0.0408 | 0.257 | 0.024 | 0.22 | 0.206 | 0.0202 | |
| 106H0605 | 106H0605 Stabilizer Reboiler | 633552.02 | 5193540.78 | 808.41 | 42 | 790.2 | 15.7 | 2 | 0.9879999 | 1.27E-06 | 0.0104 | 0.0078 | 0.0026 | 0.07799999 | 0.0015 | 0.014 | 0.0624 | 0.0013 | |
| B0202A | B0202A High Pressure Steam Boiler 1 | 633421.33 | 5193187.95 | 810.94 | 100 | 300.4 | 34.6 | 2 | 0 | 0 | 0 | 0 | 0 | 0 | 0 | 0 | 0 | 0 | 0 |
| B0202B | B0202B High Pressure Steam Boiler 2 | 633421.51 | 5193200.14 | 810.74 | 100 | 300.4 | 34.6 | 2 | 0 | 0 | 0 | 0 | 0 | 0 | 0 | 0 | 0 | 0 | 0 |
| B0201A | B0201A Medium Pressure Steam Boiler 1 | 633422.18 | 5193180.84 | 811.04 | 100 | 300.5001 | 26.5 | 1.7 | 0.327 | 5.72E-06 | 0.0467 | 0.035 | 0.0117 | 0.3504 | 0.0069 | 0.063 | 0.28 | 0.0058 | |
| B0201B | B0201B Medium Pressure Steam Boiler 2 | 633422.18 | 5193180.84 | 811.04 | 100 | 300.5001 | 26.5 | 1.7 | 0.327 | 5.72E-06 | 0.0467 | 0.035 | 0.0117 | 0.3504 | 0.0069 | 0.063 | 0.28 | 0.0058 | |
| B0201C | B0201C Medium Pressure Steam Boiler 3 | 633422.18 | 5193180.84 | 811.04 | 100 | 300.5001 | 26.5 | 1.7 | 0 | 0 | 0 | 0 | 0 | 0 | 0 | 0 | 0 | 0 | |
| CT1501A | CT1501A Cooling Tower Cell A | 633385.33 | 5193142.32 | 812.95 | 70.01312 | 84.992 | 4.986876 | 35.98999 | 0 | 0 | 0.118 | 0 | 0 | 0 | 0 | 0.0225 | 0 | 0 | |
| CT1501B | CT1501B Cooling Tower Cell B | 633389.57 | 5193142.46 | 812.78 | 70.01312 | 84.992 | 4.986876 | 35.98999 | 0 | 0 | 0.118 | 0 | 0 | 0 | 0 | 0.0225 | 0 | 0 | |
| CT1501C | CT1501C Cooling Tower Cell C | 633393.32 | 5193142.61 | 812.64 | 70.01312 | 84.992 | 4.986876 | 35.98999 | 0 | 0 | 0.118 | 0 | 0 | 0 | 0 | 0.0225 | 0 | 0 | |
| CT1501D | CT1501D Cooling Tower Cell D | 633398.06 | 5193142.76 | 812.51 | 70.01312 | 84.992 | 4.986876 | 35.98999 | 0 | 0 | 0.118 | 0 | 0 | 0 | 0 | 0.0225 | 0 | 0 | |
| CT1501E | CT1501E Cooling Tower Cell E | 633402.31 | 5193142.91 | 812.37 | 70.01312 | 84.992 | 4.986876 | 35.98999 | 0 | 0 | 0.118 | 0 | 0 | 0 | 0 | 0.0225 | 0 | 0 | |
| FL701 | FL701 HC Endosed Flare Pilots | 633610.68 | 5193648.53 | 808.9 | 58.61001 | 1000 | 40 | 2.6 | 0.0465 | 6.00E-07 | 0.0049 | 0.00367 | 0.00122 | 0.0367 | 0.00072 | 0.0068 | 0.0294 | 0.0137 | |
| FL702 | FL702 Acid Flare Pilots | 633596.26 | 5193721.25 | 808.64 | 154.31 | 1000 | 40 | 0.375 | 0.00775 | 1.00E-07 | 0.000816 | 0.000612 | 0.000204 | 0.00612 | 0.00012 | 0.0011 | 0.0049 | 0.00228 | |
| FL703 | FL703 HC Emergency Flare Pilots | 633599.3 | 5193721.35 | 808.68 | 154.4 | 1000 | 40 | 1.3 | 0.0116 | 1.50E-07 | 0.00122 | 0.000918 | 0.000306 | 0.00918 | 0.00018 | 0.00165 | 0.00734 | 0.00343 | |
| FL704 | FL704 HC Emergency Flare Pilots | 633719.61 | 5193725.62 | 806.33 | 154.4 | 1000 | 40 | 1.3 | 0.0116 | 1.50E-07 | 0.00122 | 0.000918 | 0.000306 | 0.00918 | 0.00018 | 0.00165 | 0.00734 | 0.00343 | |
| REFORM | Reformer | 633565.19 | 5193525.63 | 808.26 | 42 | 790.2 | 15.7 | 2 | 0 | 0 | 0 | 0 | 0 | 0 | 0 | 0 | 0.0605 | 0 | 0.00585 |
| SRU | SRU | 633616.95 | 5193525.47 | 806.75 | 60 | 414.5 | 50 | 1.7 | 0.42 | 0 | 0 | 0 | 0 | 0.09 | 0.04 | 0.29 | 0 | 0 | 0 |

ATTACHMENT D

Air Toxics Analysis Spreadsheets

ATTACHMENT E

Cooling Towers Visibility Study



NHOE-16-001-16-419

COOLING TOWER PLUME VISIBILITY ANALYSIS

IN SUPPORT OF AN APPLICATION FOR
AIR CONTAMINANT DISCHARGE PERMIT
MERIDIAN ENERGY GROUP, INC.
DAVIS REFINERY
BILLINGS COUNTY, NORTH DAKOTA

APRIL 2017



201 N. Church Street,
Suite 300
Las Cruces, NM 88001
Phone (575) 532-1526
Fax (575) 532-1587

COOLING TOWER PLUME VISIBILITY ANALYSIS

IN SUPPORT OF AN APPLICATION AMENDMENT FOR
AIR CONTAMINANT DISCHARGE PERMIT
MERIDIAN ENERGY GROUP, INC.
DAVIS REFINERY
BILLINGS COUNTY, NORTH DAKOTA

*Zia Project # NHOE-16-001
Document # NHOE-16-001-16-419 Attachment E
Submission Date: April 2017*

Submitted To: **North Dakota Department of Health
Air Quality Division**

On behalf of: **VEPICA USA, Inc.
2002 W Grand Parkway North, Suite 200
Katy, TX 77449**

Submitted by:

Author(s):



201 N. Church Street, Suite 300
Las Cruces, New Mexico 88001
(575) 532-1526 voice
(575) 532-1587 fax

Miguel A. Martinez

Edward H. Martinez, PE

EXECUTIVE SUMMARY

The ND-DAQ requested a non-regulatory visibility study to determine if the cooling tower condensation plume rise from the proposed North Dakota Davis Refinery (NDDR) site would be visible at observation points at the Theodore Roosevelt National Park (TRNP). The proposed site for the NDDR is 5.5 km from the east boundary of the TRNP and some members of the public have expressed concern that the cooling tower condensation plume rise could affect the horizon visibility from the National Park. The results of the requested visibility report are provided for informational purposes only since there are no regulatory requirements for visibility analysis for a synthetic minor source facility.

The non-regulatory required visibility study considered four observation points located within the TRNP:

- The Amphitheater
- The TRNP Visitor Center
- Painted Canyon Visitor Center
- Buckhill Trail

The visibility study used the Seasonal/Annual Cooling Tower Impact Model, Version 2 (SACTI2), a mathematical model available from the Electric Power Research Institute. The model helps predict the direction, height, and frequency of the formation of a condensation plume from a cooling tower. The factors that affect the visibility of the plume are Meteorology, the rise of the condensation plume, the curvature of the earth, and the topography of the region.

The SACTI model and the factors suggest the Buckhill Trail will be the only observation point where the cooling tower plumes have the potential to be visible. The eastern horizon from the trail is 866 m above sea level (ASL) at a distance of 12.2 km from the proposed plant site. The SACTI model results indicate that the top portion (ΔH) of fifteen plumes might be visible above the horizon with the maximum visible height at 12.2 km being approximately 7.5 meters (see Table 10). It should be noted that at a distance of 12.2 km, it would be very hard to distinguish a height of 7.5 meters from the surrounding terrain. It should also be noted that there is no regulatory constraint related to plume visibility for the Class I area. A full summary and discussion of all visibility results is included in Attachment E of this Model Analysis.

Visible Plumes Above the Buckhill Trail Horizon (Easterly Direction)

| Height | ASL (m) | Delta H (m) | | Height | ASL (m) | Delta H (m) |
|--------|---------|-------------|--|--------|---------|-------------|
| 53.5 | 873.5 | 7.5 | | 49.6 | 869.6 | 3.6 |
| 53.3 | 873.3 | 7.3 | | 49.6 | 869.6 | 3.6 |
| 51.1 | 871.1 | 5.1 | | 49.6 | 869.6 | 3.6 |
| 50.8 | 870.8 | 4.8 | | 49.5 | 869.5 | 3.5 |
| 50.7 | 870.7 | 4.7 | | 48.8 | 868.8 | 2.8 |
| 50.0 | 870.0 | 4.0 | | 48.6 | 868.6 | 2.6 |
| 49.9 | 869.9 | 3.9 | | 46.2 | 866.2 | 0.2 |
| 49.8 | 869.8 | 3.8 | | | | |

TABLE OF CONTENTS

| | |
|--|------------|
| EXECUTIVE SUMMARY | III |
| 1.0 INTRODUCTION..... | 1 |
| 2.0 METEOROLOGICAL DATA..... | 1 |
| 2.1 Average Daily Solar Insolation | 2 |
| 2.2 Clearness Index | 2 |
| 2.3 Drop Spectrum | 2 |
| 3.0 MODEL DATA PROCESSING | 3 |
| 4.0 TERRAIN ANALYSIS | 4 |
| 4.1 Curvature of the Earth | 4 |
| 4.2 Local Topography..... | 5 |
| 5.0 CONCLUSION | 6 |
| 6.0 REFERENCES..... | 7 |

| | |
|------------|---------------------------------|
| Appendix A | Cooling Tower Physical Data |
| Appendix B | Plume Characteristics - Results |
| Appendix C | Horizon Curvature Calculations |
| Appendix D | Plume Visibility Figures |

List of Tables

| | |
|--|-----|
| Visible Plumes Above the Buckhill Trail Horizon (Easterly Direction) | iii |
| Table 1. Summary of Thermal Characteristics of the Five Cell Cooling Tower..... | 1 |
| Table 2. Meteorological Data Extracted by AERMET for the Condensate Plume Rise Model..... | 3 |
| Table 3. Condensate Plume Rise Height in Meters Condensate Plume Rise Model | 4 |
| Table 4. Category 32 Condensate Plume Rise Height in Meters Condensate Plume Rise Model..... | 4 |
| Table 5. Distance Between the National Park Observation Points and the Proposed North Dakota Davis Refinery Cooling Tower | 4 |
| Table 6. Line of Sight Intercept with the Horizon | 5 |
| Table 7. Visible Plumes Above the Buckhill Trail Horizon (Easterly Direction)..... | 5 |

COOLING TOWER PLUME VISIBILITY ANALYSIS

1.0 INTRODUCTION

The cooling tower battery that is the subject of the visibility study is a modular unit with five (5) cooling cells. Each cell has a heat rejection rate of 3.3 MW* h with an estimated drift loss of 0.1 gallons of water per minute. The dimensions of the five (5) cell cooling tower configuration are in Appendix A. Table 1 summarizes the thermal characteristics of the cooling tower.

*Table 1. Summary of Thermal Characteristics of the Five Cell Cooling Tower
Proposed North Dakota Davis Refinery*

| Cooling Tower Cell Output | | | Heat Rejection | | |
|---------------------------|--------|---------------|----------------|-------|---------------|
| Number of cells: | 5 | | kW per cell | 11.25 | MMBTU/h |
| Air Flow: | 145730 | cfm/cell | MW | 3.3 | MW/h per Cell |
| | 78.09 | kg/s per cell | | 16.5 | MW*h Total |
| Total Air Flow | 390.4 | kg/s | | | |

The visibility study used the *Seasonal/Annual Cooling Tower Impact Model, Version 2* (SACTI2), published by the Electric Power Research Institute [1]. The model requires a set of data to properly characterize the types of condensation plumes that can be expected for the proposed site. The data inputs are:

- Integrated Hourly Surface Data (IHSD) Meteorology
- Upper Air Radiosonde Observations
- Average Daily Solar Insolation
- Clearness Index
- Drop Distribution Spectrum

2.0 METEOROLOGICAL DATA

The plume condensation visibility study selected the year 2013 as the representative meteorological year. The year 2013 is part of a separate regulatory-required model submitted to the North Dakota Department of Health Air Quality Department.

The Integrated Hourly Surface Data (ISD) Meteorology data for the year 2013 were downloaded from the *National Oceanic and Atmospheric Administration (NOAA) National Centers for Environmental Information* website [2]. The surface observation station closest to the proposed refinery site is:

Dickinson Municipal Airport (KDIK)
Station Number 24012
WBAN Number 72764
Base elevation 787.3 meter

The upper air observations were downloaded from the NOAA Earth System Research Laboratory (ESRL) website [3]. The observation station nearest to the proposed refinery site is:

Bismarck Municipal Airport (KBIS)
Station Number 24011
WBAN Number 72764

2.1 AVERAGE DAILY SOLAR INSOLATION

The visibility study used the 30-day average solar radiation for a flat plate collector facing south at a fixed tilt for the Bismarck, ND (WBAN No. 24011) station [4]. Solar radiation plays a role in the lifting of a condensation plume. Solar radiation heats the air around the cooling tower creating a temperature differential. The plume from the cooling tower exchanges heat with the surrounding air and condensate into droplets when the psychrometric conditions are met. Solar radiation also causes convective forces around the cooling tower by reflection from surfaces around the cooling tower cells. The resulting convection imparts both a mixing and a rising force on the cooling tower plume. Convection is the primary factor in the dispersion of the cooling tower water plume.

2.2 CLEARNESS INDEX

The Clearness Index (K_T) is the ratio of the horizontal global irradiance and the irradiance outside the atmosphere. The Clearness Index is preeminent in solar panel projects since it is a measure of the available solar radiation available for conversion into electrical energy. The monthly clearness index was calculated using the 30-day average solar radiation for KBIS Station 24011.

2.3 DROP SPECTRUM

The water vapor leaving the cooling tower exchanges heat with the surrounding ambient air forming a condensation plume. The drop size distribution of condensate is approximate to the type of cooling tower generating the plume. The proposed North Dakota Davis Refinery will have a Linear Mechanical Draft Cooling Tower (LMDCT) using electrically driven fans to impress an airflow of 145, 730 cubic feet per minute (390.4 kg Air/s).

The model used the drop spectrum for a linear mechanical draft cooling tower (LMDCT) furnished in the SACTI documentation. The condensate droplet distribution for the LMDCT was proposed by Policastro *et al* for cooling tower plume dispersion.

3.0 MODEL DATA PROCESSING

The visibility study first processed the integrated hourly surface meteorological data using AERMET [7] to extract the parameters used for the plume rise calculations:

*Table 2. Meteorological Data Extracted by AERMET for the
Condensate Plume Rise Model*

| | |
|----------------------|-----------------------|
| Total Sky Cover | Dry Bulb Temperature |
| Cloud Ceiling Height | Dew Point Temperature |
| Wind Direction | Relative Humidity |
| Wind Velocity | |

The visibility study continued the processing by extracting the upper air temperatures and wind velocities from the radiosonde observations. The study applied the extracted data to the *HolzworthZi.exe* module to calculate the morning and afternoon mixing heights for the upper atmosphere.

The visibility study model combined all the cooling tower operating parameters, extracted meteorological data, solar radiation, and drop spectrum into the required *SACTI2.inp* file. The file is formatted to allow the *SACTI2.exe* module to generate the condensate plume length and height in 16 equally-spaced 22.5° angular sectors. The *SACT2.exe* module summarizes its results in a file named *Tables.out*.

The visibility study divided the analysis of the *Tables.out* results into two classes:

- Plumes with radii greater than zero
- Plumes with radii equal to zero

The *SACTI.exe* program results divide plumes into 33 different categories when it considers the meteorological conditions that affect dispersion and transport of the condensation plume. Some categories address fogging and icing conditions on or near the cooling tower. The fogging and icing categories will have plume rises that are either negative or close to ground level.

Thirty-two categories result in plumes with radii greater than zero. Table 3 summarizes the twenty highest values of plume rise.

Category 32 is a special case for plume rise analysis. The category accounts for surface and upper air meteorological conditions that allow dispersion of the condensation plume over a greater distance and height. The radius of a plume in this category is considered zero and outside the center line of the dispersion path. Plumes can extend up to 10,000 meters from the cooling tower. Table 4 summarizes all results for Category 32 plumes. Only sixteen Category 32 plumes happen over the 2013 period analyzed. Condensate plume rise tables are included in Appendix B.

Table 3. Condensate Plume Rise Height in Meters Condensate Plume Rise Model

| Heading (degrees) | Height (m) | Radius (m) | Heading (degrees) | Height (m) | Radius (m) |
|-------------------|------------|------------|-------------------|------------|------------|
| 0 | 53.5 | 15.1 | 315 | 49.6 | 15.1 |
| 180 | 53.3 | 14.9 | 157.5 | 49.5 | 15.2 |
| 90 | 51.1 | 14.7 | 112.5 | 48.8 | 14.7 |
| 135 | 50.8 | 15.3 | 67.5 | 48.6 | 14.2 |
| 45 | 50.7 | 15 | 292.5 | 46.2 | 13.8 |
| 202.5 | 50 | 15.2 | 270 | 45.4 | 13.8 |
| 225 | 49.9 | 15.1 | 22.5 | 41.4 | 12.9 |
| 22.5 | 49.8 | 15.1 | 112.5 | 41.3 | 12.7 |
| 247.5 | 49.6 | 14.9 | 67.5 | 41.2 | 12.7 |
| 337.5 | 49.6 | 15.2 | 157.5 | 41.1 | 12.9 |

Table 4. Category 32 Condensate Plume Rise Height in Meters Condensate Plume Rise Model

| Heading (degrees) | Height (m) | Radius (m) | Heading (degrees) | Height (m) | Radius (m) |
|-------------------|------------|------------|-------------------|------------|------------|
| 225.0 | 19925.5 | 439.2 | 0.0 | 19926.1 | 438.6 |
| 90.0 | 19924.5 | 439.1 | 180.0 | 19926.2 | 438.2 |
| 270.0 | 19925.4 | 439.1 | 135.0 | 19924.7 | 438.0 |
| 292.5 | 19925.4 | 439.0 | 45.0 | 19924.7 | 437.6 |
| 112.5 | 19924.6 | 439.0 | 202.5 | 19926.0 | 435.7 |
| 315.0 | 19925.6 | 438.9 | 22.5 | 19925.5 | 435.6 |
| 247.5 | 19925.7 | 438.8 | 157.5 | 19925.0 | 435.1 |
| 67.5 | 19924.7 | 438.7 | 337.5 | 19926.1 | 435.1 |

4.0 TERRAIN ANALYSIS

4.1 CURVATURE OF THE EARTH

The curvature of the earth is a factor that was considered to determine if the condensation plume might be visible from the observation points at the Theodore Roosevelt National Park. The distances between the observation points are:

Table 5. Distance Between the National Park Observation Points and the Proposed North Dakota Davis Refinery Cooling Tower

| Observation Point | d (km) |
|-------------------------------|--------|
| Painted Canyon Visitor Center | 10.36 |
| Buckhill Trail Parking Center | 12.06 |
| Amphitheater | 22.98 |
| TRNP Visitor Center | 21.46 |

Assuming no topography between the observation points and the cooling tower, the lines of sights intercept the horizon in an easterly direction at the following points:

Table 6. Line of Sight Intercept with the Horizon

| | Observation Point Elevation | Horizon Intercept |
|-------------------------------|-----------------------------|-------------------|
| Observation Point | h (km) | y (km) |
| Painted Canyon Visitor Center | 0.85 | 104.0 |
| Buckhill Trail Parking Center | 0.85 | 104.2 |
| Amphitheater | 0.76 | 98.7 |
| TRNP Visitor Center | 0.69 | 93.9 |

The cooling tower location is within the range of the line of sight of the observation points, since y (km) is greater than d(km). Thus, absent any topographic obstacles, the cooling tower might be visible from the observation points.

The SACTI model results and the factors suggest the Buckhill Trail will be the only observation point where the cooling tower plumes might be visible. The eastern horizon from the trail is 866 m above sea level (ASL) at a distance of 12.2 km. The SACTI model results indicate that the top portion (ΔH) of fifteen plumes might be visible above the horizon:

Table 7. Visible Plumes Above the Buckhill Trail Horizon (Easterly Direction)

| Height | ASL (m) | Delta H (m) | Height | ASL (m) | Delta H (m) |
|--------|---------|-------------|--------|---------|-------------|
| 53.5 | 873.5 | 7.5 | 49.6 | 869.6 | 3.6 |
| 53.3 | 873.3 | 7.3 | 49.6 | 869.6 | 3.6 |
| 51.1 | 871.1 | 5.1 | 49.6 | 869.6 | 3.6 |
| 50.8 | 870.8 | 4.8 | 49.5 | 869.5 | 3.5 |
| 50.7 | 870.7 | 4.7 | 48.8 | 868.8 | 2.8 |
| 50.0 | 870.0 | 4.0 | 48.6 | 868.6 | 2.6 |
| 49.9 | 869.9 | 3.9 | 46.2 | 866.2 | 0.2 |
| 49.8 | 869.8 | 3.8 | | | |

The Pythagorean geometry used for the curvature of the earth calculations are included in Appendix C.

4.2 LOCAL TOPOGRAPHY

The visual study also considered the local topography to determine if the condensation plume would be visible from the observation points. The study generated cross sections of the terrain profiles using the path available in Google Earth Pro.

The path tool helps draw a straight line between the observation point and the cooling tower location. An option within the tool then displays an elevation profile of the terrain between the two points. The cross sections generated in Google Earth do not take in consideration the curvature of the earth and the elevations of the terrain displayed are above sea level. The resulting cross sections are included in Appendix D.

There were one or more terrain features higher than the elevation of the observation points, features that effectively block the possible view of the condensation plume generated by the cooling tower.

The exception is the Buckhill Trail observation point. The visibility study calculated the maximum rise of the normal plumes is 53.5 meters. Theoretically, the top 7.5 meter of the plume would be visible from the Buckhill Trail observation point, which is located 12.2 km from the cooling tower.

5.0 CONCLUSION

The visibility study analyzed the plume rise from a linear mechanical draft cooling tower from the proposed North Dakota Davis Refinery (NDDR). The study used the meteorological data for 2013, the operating characteristics of the cooling tower, and the *Seasonal/Annual Cooling Tower Impact Model*, Version 2 (SACTI2) available from the Electric Power Research Institute to determine the height of condensate plume rise.

The visibility study concluded the NDDR cooling tower condensation plume would possibly be visible from the Buckhill Trail observation point. Table 7 of the report summarizes the frequency of possible observation of the visible plumes.

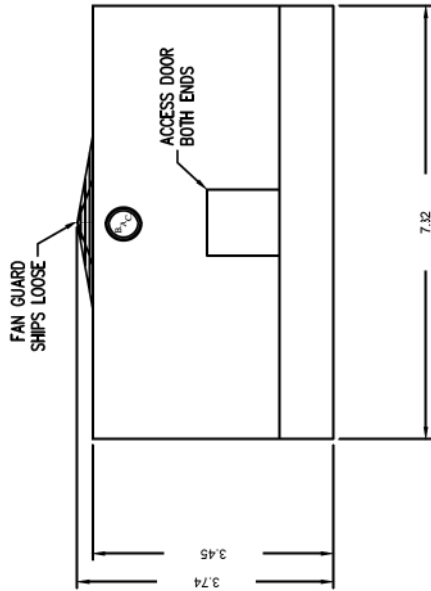
6.0 REFERENCES

- [1] Electric Power Research Institute , 3420 Hillview Avenue, Palo Alto, California 94304, <https://www.epri.com/#/>
- [2] *National Oceanic and Atmospheric Administration (NOAA) National Centers for Environmental Information*, <http://www.ncdc.noaa.gov/isd/data-access>
- [3] *NOAA Earth System Research Laboratory (ESRL)*, <http://www.esrl.noaa.gov/raobs/>
- [4] Ndilemeni, C.C., Momoh, M., Akande, J.O., *Evaluation of Clearness Index of Sokoto Using Estimated Solar Radiation*, IOSR Journal Of Environmental Science, Toxicology And Food Technology (IOSR-JESTFT) e-ISSN: 2319-2402,p- ISSN: 2319-2399. Volume 5, Issue 3 (Jul. - Aug. 2013), PP 51-54 www.iosrjournals.org
- [5] U.S. Department of Energy National Renewable Energy Laboratory, Hourly Solar Radiation Surface Meteorological Observations, WBAN 24011 Bismarck, ND. , 1961-1991 Average, http://rredc.nrel.gov/solar/old_data/nsrdb/
- [6] Policastro, A.J., W.E. Dunn, M. Breig and K. Haake, *Studies on Mathematical Models for Characterizing Plume and Drift Behavior from Cooling Towers*, 1981, Volume 5. Mathematical Models for Multiple-Source (Multiple-Tower) Cooling Tower Plume Dispersion. EPRI Report No. EPRI CS-1683. Volume 5. January 1981.
- [7] EPA, 2004. *User's Guide for the AERMOD Meteorological Preprocessor (AERMET)*. Publication No. EPA-454/B-03-002. U.S. Environmental Protection Agency, Research Triangle Park, NC. http://www.epa.gov/ttn/scram/metobsdata_procaccprogs.htm#aermet

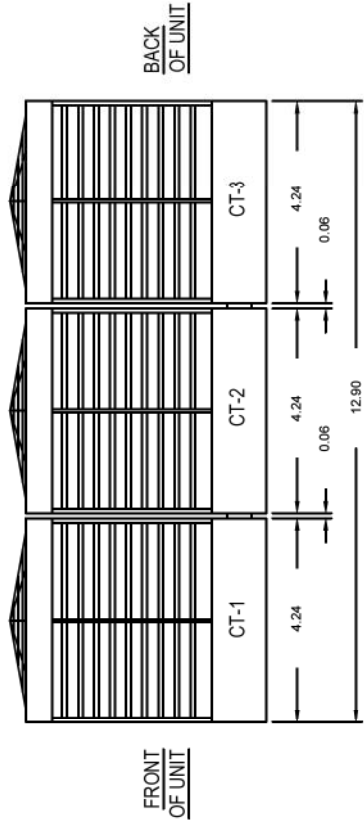
APPENDIX A

Cooling Tower Physical Data

CONVERSION OF UNITS TO METERS



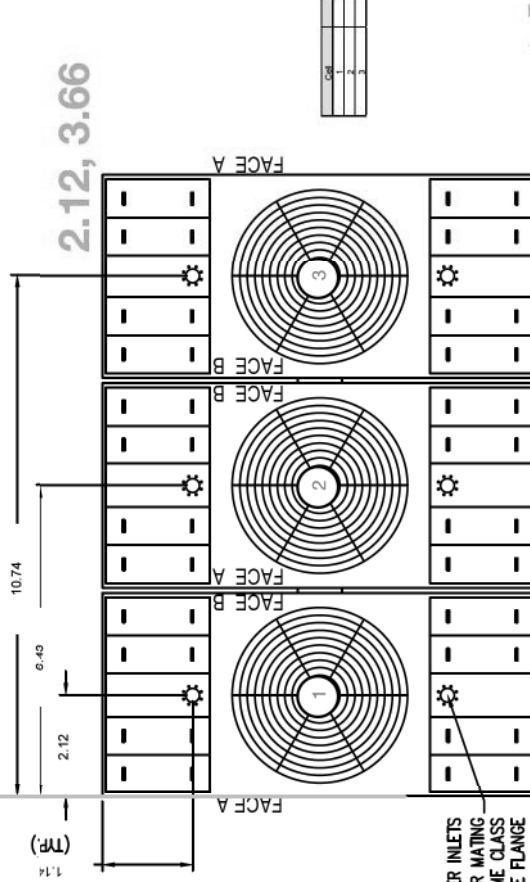
END ELEVATION (FACE A)



SIDE ELEVATION

Notes

- 1) Drawings are not to scale. All dimensions are in feet and inches. Weights are in pounds and include options and accessories.
- 2) Unless otherwise indicated, connections 3" and smaller are MPT. Connections 4" and larger are grooved to suit a mechanical coupling and beveled for welding.
- 3) Field piping should be fabricated at time of installation. Pre-fabrication of pipe work is not recommended.
- 4) Do not support piping from unit connections. All necessary piping supports to be supplied by others.
- 5) For weight loadings and support requirements, refer to the suggested unit support drawing.
- 6) The area above the fan discharge must be unobstructed.
- 7) Due to height limitations on truck shipments, some items shown may ship loose for field installation.



PLAN VIEW

| Code | X Dim | Y Dim |
|------|-------|-------|
| 1 | 2.12 | 3.66 |
| 2 | 6.43 | 3.66 |
| 3 | 10.73 | 3.66 |

8" TOP WATER INLETS
STUD CIRCLE FOR MATING
WITH AN ASME CLASS
150 FLAT FACE FLANGE

| Model Number | Shipping Weight | Operating Weight | Heaviest Section |
|------------------|-----------------|------------------|------------------|
| XES3E-1424-07N-3 | 50880 | 105000 | 16610 |

ORDER NO: **95941_XES3E-1424-07N-3**

DATE: **8/9/2016 5:21:51 PM**



3000E Unit Print
One Piece Units
DRAWING NUMBER:
UP-95941 XES3E-1424-07N-3

Baltimore Aircoil Company, Inc.
Cooling Tower Selection Program

Version: 8.7.3 NA
Product data correct as of: June 30, 2016

Project Name: North Dakota Refinery
Selection Name: Open Cell Cooling Tower -Summer
Project State/Province: Alberta
Project Country: Canada
Date: August 04, 2016

Model Information

Product Line: New Series 3000
Model: XES3E-1424-07N
Number of Units: 1
Fan Type: Standard Fan
Fan Motor: (1) 25.00 = 25.00 HP/Unit
Total Standard Fan Power: Full Speed, 25.00 BHP/Unit
Intake Option: None
Internal Option: None
Discharge Option: None

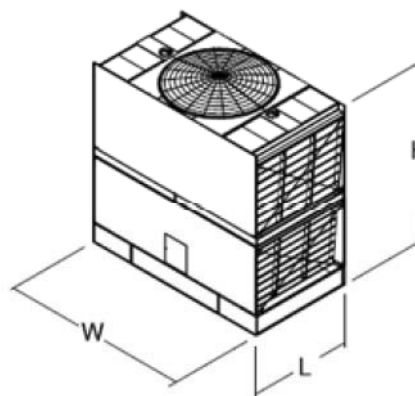
Design Conditions

Flow Rate: 1,500.00 USGPM
Hot Water Temp.: 95.00 °F
Cold Water Temp.: 80.00 °F
Wet Bulb Temp.: 70.00 °F
Tower Pumping Head: 4.91 psi
Reserve Capability: 2.04 %

Thermal performance at design conditions and standard total fan motor power is certified by the Cooling Technology Institute (CTI).

Engineering Data, per Unit

Unit Length: 13' 11.25"
Unit Width: 24' 00.50"
Unit Height: 12' 03.00"
Air Flow: 145,730 CFM
Approximate Shipping Weight: 16,410 pounds
Heaviest Section: 16,410 pounds
Approximate Operating Weight: 34,450 pounds
Heater kW Data (Optional)
0°F (-17.8°C) Ambient Heaters: (2) 14 kW
-20°F (-28.9°C) Ambient Heaters: (2) 18 kW



Minimum Distance Required for Single Unit:

(For multiple units, refer to Layout Guidelines)

From Solid Wall: 6 ft.
From 50% Open Wall: 3 ft.

Energy Rating:

84.68 per ASHRAE 90.1, ASHRAE 189 and CA Title 24.

This XE model is an extremely efficient model, with a base energy rating that meets or exceeds 2x the minimum ASHRAE 90.1 energy rating.

Note: These unit dimensions account for the selected fan type for the standard cataloged drive configuration, but they do not account for other options/accessories. Please contact your local BAC sales representative for dimensions of units with other options/accessories.

Baltimore Aircoil Company, Inc.
Cooling Tower Selection Program

Version: 8.7.3 NA
Product data correct as of: June 30, 2016

Project Name: North Dakota Refinery
Selection Name: Open Cell Cooling Tower -Summer
Project State/Province: Alberta
Project Country: Canada
Date: August 04, 2016

Model & Fan Motor

Product Line: New Series 3000
Model: XES3E-1424-07N
Number of Units: 1
Fan Motor: (1) 25.00 = 25.00 HP/Unit
Total Standard Fan Power: Full Speed, 25.00 BHP/Unit

Model Accessories

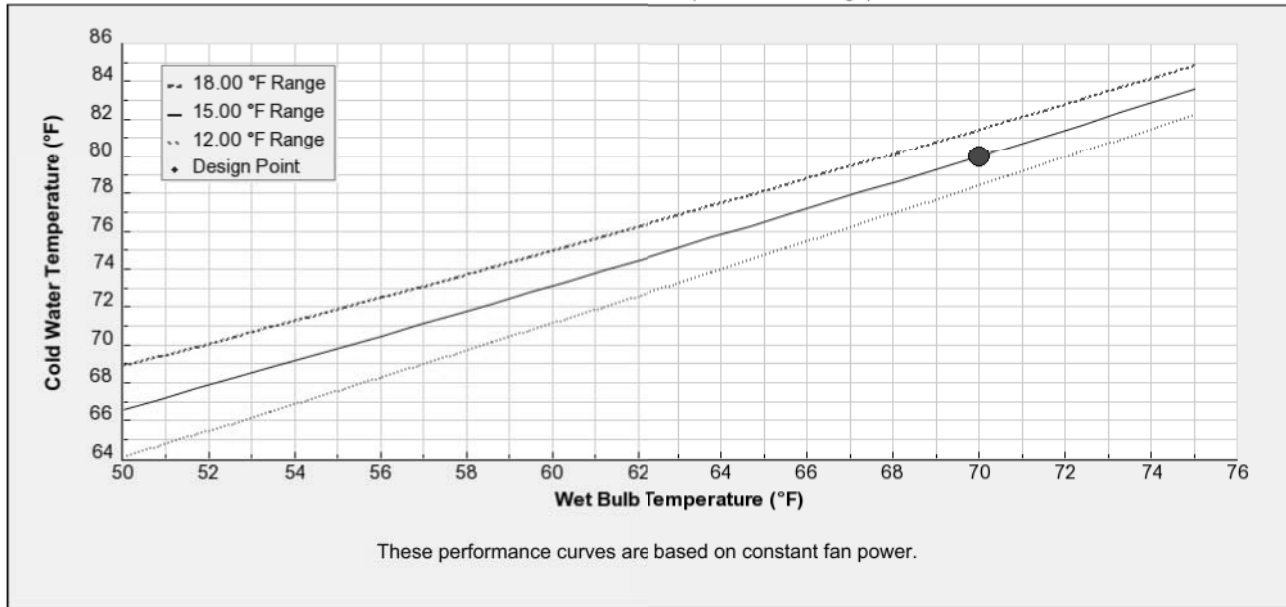
Intake Option: None
Internal Option: None
Discharge Option: None
Fan Type: Standard Fan

Design Conditions @ Standard Total Fan Motor Power per Unit (25.00 HP)

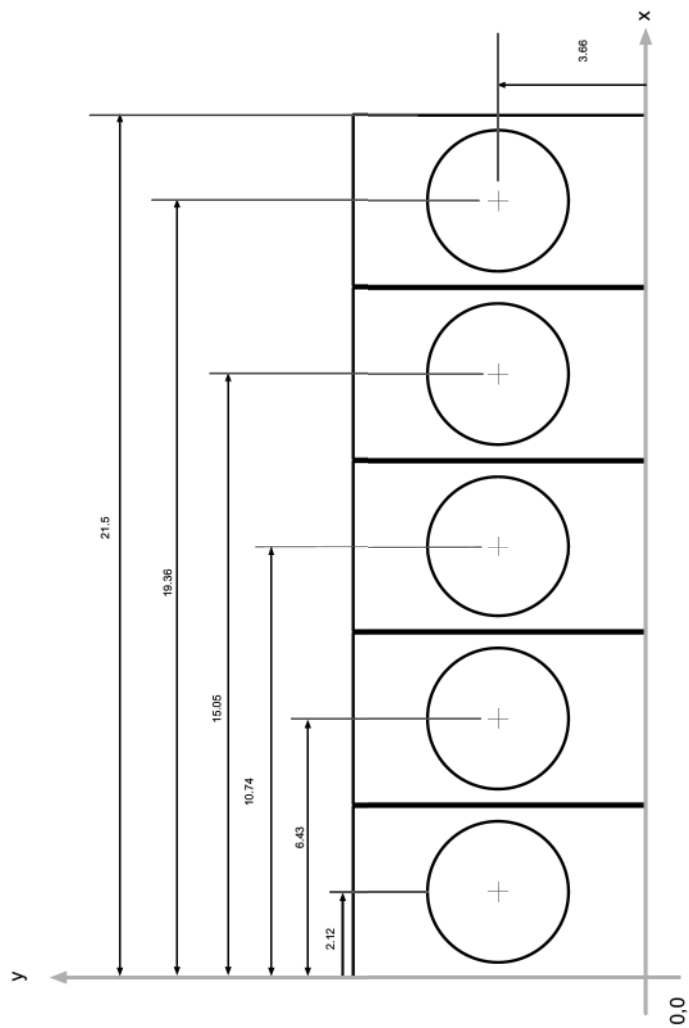
Thermal performance at design conditions and standard total fan motor power is certified by the Cooling Technology Institute (CTI).

Flow Rate: 1,500.00 USGPM
Hot Water Temp.: 95.00 °F
Cold Water Temp.: 80.00 °F
Wet Bulb Temp.: 70.00 °F

Predicted Performance
Fan Motor Alternative = Full Speed, 25.00 BHP
Flow Rate = 1500.00 USGPM (100.00% of Design)



Relative Coordinates for Cooling Tower Cells in meters



APPENDIX B

Plume Characteristics – Results

| Category | Length | Height | Radius | Heading |
|----------|---------|--------|--------|---------|
| 1 | 12.4 | 7.9 | 4.2 | 0 |
| 2 | 25.6 | 14.4 | 7.3 | 0 |
| 3 | 23.9 | 6.8 | 4.9 | 0 |
| 4 | 37.8 | 11.9 | 6.9 | 0 |
| 5 | 46.8 | 16 | 8 | 0 |
| 6 | 29.6 | 4.3 | 3.6 | 0 |
| 7 | 69.5 | 7.7 | 5 | 0 |
| 8 | 179.5 | 11.9 | 6.5 | 0 |
| 9 | 12.5 | 7.8 | 4.6 | 0 |
| 10 | 49.6 | 21.8 | 11 | 0 |
| 11 | 52.3 | 26.8 | 11.5 | 0 |
| 12 | 38.6 | 9.6 | 6 | 0 |
| 13 | 62.3 | 17.2 | 8.6 | 0 |
| 14 | 71.2 | 21.1 | 9.3 | 0 |
| 15 | 118.9 | 15.6 | 7.1 | 0 |
| 16 | 30.5 | 15.9 | 8.7 | 0 |
| 17 | 72.7 | 16.9 | 8.1 | 0 |
| 18 | 77.3 | 19 | 8.6 | 0 |
| 19 | 108 | 19.3 | 8.2 | 0 |
| 20 | 107.5 | 21.6 | 8.9 | 0 |
| 21 | 117.5 | 22.9 | 9.2 | 0 |
| 22 | 127.6 | 23.4 | 9.5 | 0 |
| 23 | 147.4 | 26.2 | 9.7 | 0 |
| 24 | 157 | 29 | 10.4 | 0 |
| 25 | 156.3 | 31.8 | 11.1 | 0 |
| 26 | 176.5 | 33 | 11.5 | 0 |
| 27 | 196.3 | 35.7 | 12.1 | 0 |
| 28 | 196.1 | 36.7 | 12.4 | 0 |
| 29 | 236 | 40.6 | 12.9 | 0 |
| 30 | 284.1 | 53.5 | 15.1 | 0 |
| 31 | 51.5 | 18.5 | 8.7 | 0 |
| 32 | 19926.1 | 438.6 | 0 | 0 |
| 33 | 99 | 13.9 | 6.6 | 0 |
| 1 | 7.5 | 6.2 | 2.5 | 22.5 |
| 2 | 11.4 | 7.7 | 4.8 | 22.5 |
| 3 | 23.7 | 7 | 3 | 22.5 |
| 4 | 37.7 | 9.6 | 4.9 | 22.5 |
| 5 | 36.7 | 12 | 5.9 | 22.5 |
| 6 | 34.5 | 3.5 | 2.2 | 22.5 |
| 7 | 89.5 | 4.8 | 5 | 22.5 |
| 8 | 259.6 | 4 | 6.5 | 22.5 |
| 9 | 12.3 | 6.6 | 2.7 | 22.5 |
| 10 | 24.7 | 12.5 | 6.7 | 22.5 |
| 11 | 14 | 11.9 | 6.2 | 22.5 |
| 12 | 38.6 | 6.1 | 4.3 | 22.5 |
| 13 | 62.1 | 15 | 8.4 | 22.5 |
| 14 | 61 | 17.8 | 8.9 | 22.5 |
| 15 | 128.9 | 14.1 | 7 | 22.5 |
| 16 | 16 | 8.1 | 5.6 | 22.5 |
| 17 | 72.7 | 13.6 | 8.2 | 22.5 |
| 18 | 77.2 | 15.8 | 8.8 | 22.5 |
| 19 | 118 | 19.6 | 8.2 | 22.5 |
| 20 | 117.4 | 22.3 | 9 | 22.5 |

| Category | Length | Height | Radius | Heading |
|----------|---------|--------|--------|---------|
| 21 | 117.5 | 22.1 | 9.1 | 22.5 |
| 22 | 137.5 | 24 | 9.2 | 22.5 |
| 23 | 147.4 | 25.3 | 9.4 | 22.5 |
| 24 | 157 | 28 | 10.1 | 22.5 |
| 25 | 146.3 | 27.2 | 11.3 | 22.5 |
| 26 | 176.4 | 32.6 | 11.3 | 22.5 |
| 27 | 206.1 | 36.7 | 12.3 | 22.5 |
| 28 | 205.9 | 37.6 | 12 | 22.5 |
| 29 | 245.8 | 41.4 | 12.9 | 22.5 |
| 30 | 274 | 49.8 | 15.1 | 22.5 |
| 31 | 51.2 | 16.1 | 8.6 | 22.5 |
| 32 | 19925.5 | 435.6 | 0 | 22.5 |
| 33 | 109 | 11.8 | 6.6 | 22.5 |
| 1 | 7.5 | 6.2 | 2.5 | 45 |
| 2 | 11.3 | 9.2 | 3.4 | 45 |
| 3 | 28.6 | 5.8 | 3.1 | 45 |
| 4 | 37.5 | 10 | 4.9 | 45 |
| 5 | 26.8 | 9.8 | 5.4 | 45 |
| 6 | 34.4 | 4.6 | 2.4 | 45 |
| 7 | 79.5 | 5.9 | 5.1 | 45 |
| 8 | 229.6 | 2.1 | 6.4 | 45 |
| 9 | 12.2 | 7 | 3.3 | 45 |
| 10 | 15.8 | 10.1 | 4.9 | 45 |
| 11 | 10 | 10.4 | 4.3 | 45 |
| 12 | 43.4 | 8 | 4.9 | 45 |
| 13 | 61.8 | 15.7 | 8.2 | 45 |
| 14 | 45.9 | 15.6 | 7.6 | 45 |
| 15 | 118.9 | 14.2 | 7 | 45 |
| 16 | 15.9 | 9.9 | 3.9 | 45 |
| 17 | 72.5 | 14.9 | 8.1 | 45 |
| 18 | 77 | 17.3 | 8.5 | 45 |
| 19 | 108 | 16.3 | 8.2 | 45 |
| 20 | 107.4 | 19.3 | 9.3 | 45 |
| 21 | 117.4 | 20.4 | 9.2 | 45 |
| 22 | 127.5 | 20.9 | 9.5 | 45 |
| 23 | 147.3 | 23.4 | 9.7 | 45 |
| 24 | 146.9 | 25.1 | 10.2 | 45 |
| 25 | 146.1 | 28.6 | 11.3 | 45 |
| 26 | 176.3 | 30.9 | 11.4 | 45 |
| 27 | 196.1 | 33.6 | 11.8 | 45 |
| 28 | 195.8 | 34.7 | 12 | 45 |
| 29 | 235.7 | 38.6 | 13.2 | 45 |
| 30 | 273.7 | 50.7 | 15 | 45 |
| 31 | 50.9 | 16.8 | 8.5 | 45 |
| 32 | 19924.7 | 437.6 | 0 | 45 |
| 33 | 109 | 12.9 | 6.6 | 45 |
| 1 | 12.2 | 8 | 2.5 | 67.5 |
| 2 | 11.2 | 9.2 | 3.4 | 67.5 |
| 3 | 33.2 | 9.2 | 3.6 | 67.5 |
| 4 | 42.3 | 13 | 4.7 | 67.5 |
| 5 | 31.5 | 13 | 4.1 | 67.5 |
| 6 | 29.3 | 3.8 | 2.4 | 67.5 |
| 7 | 74.4 | 4.7 | 5 | 67.5 |

| Category | Length | Height | Radius | Heading |
|----------|---------|--------|--------|---------|
| 8 | 149.5 | -0.8 | 6.3 | 67.5 |
| 9 | 12.2 | 7.9 | 2.7 | 67.5 |
| 10 | 15.6 | 10.2 | 4.2 | 67.5 |
| 11 | 10 | 10.4 | 4.3 | 67.5 |
| 12 | 43.1 | 10.9 | 5.2 | 67.5 |
| 13 | 66.7 | 18.4 | 8 | 67.5 |
| 14 | 50.7 | 18.4 | 7.5 | 67.5 |
| 15 | 108.8 | 12.1 | 7.1 | 67.5 |
| 16 | 11.4 | 9 | 3.9 | 67.5 |
| 17 | 8.6 | 4.8 | 2.2 | 67.5 |
| 18 | 8.4 | 5 | 2.3 | 67.5 |
| 19 | 107.7 | 19.6 | 8.1 | 67.5 |
| 20 | 107 | 22.3 | 8.7 | 67.5 |
| 21 | 117 | 23.4 | 8.9 | 67.5 |
| 22 | 127.1 | 24 | 9 | 67.5 |
| 23 | 137 | 25.3 | 9.4 | 67.5 |
| 24 | 146.6 | 28 | 10.1 | 67.5 |
| 25 | 115.2 | 28.5 | 9.8 | 67.5 |
| 26 | 175.9 | 33.7 | 11.1 | 67.5 |
| 27 | 195.7 | 36.3 | 12 | 67.5 |
| 28 | 195.5 | 37.4 | 12 | 67.5 |
| 29 | 235.4 | 41.2 | 12.7 | 67.5 |
| 30 | 212.7 | 48.6 | 14.2 | 67.5 |
| 31 | 55.7 | 18.3 | 8.4 | 67.5 |
| 32 | 19924.7 | 438.7 | 0 | 67.5 |
| 33 | 94 | 10.6 | 10.6 | 67.5 |
| 1 | 12.2 | 8 | 2.5 | 90 |
| 2 | 11.2 | 9.2 | 3.4 | 90 |
| 3 | 33.3 | 8.7 | 2.8 | 90 |
| 4 | 37.3 | 12 | 4.5 | 90 |
| 5 | 22 | 8.4 | 3.8 | 90 |
| 6 | 29.3 | 5.7 | 2.7 | 90 |
| 7 | 64.3 | 8 | 5.1 | 90 |
| 8 | 159.4 | 9.8 | 6.5 | 90 |
| 9 | 12.2 | 7.9 | 2.7 | 90 |
| 10 | 15.6 | 10.2 | 4.2 | 90 |
| 11 | 10 | 10.4 | 4.3 | 90 |
| 12 | 43.2 | 10.3 | 4.7 | 90 |
| 13 | 61.7 | 16.3 | 7.9 | 90 |
| 14 | 40.9 | 14.8 | 6.2 | 90 |
| 15 | 108.7 | 15 | 7 | 90 |
| 16 | 11.4 | 9 | 3.9 | 90 |
| 17 | 77.2 | 17.8 | 7.8 | 90 |
| 18 | 76.8 | 17.9 | 8.5 | 90 |
| 19 | 9 | 4.1 | 2 | 90 |
| 20 | 107.2 | 21.5 | 8.6 | 90 |
| 21 | 117.2 | 22.5 | 8.9 | 90 |
| 22 | 91.8 | 21.7 | 8.2 | 90 |
| 23 | 106.6 | 24.1 | 8.4 | 90 |
| 24 | 146.8 | 27.2 | 10.1 | 90 |
| 25 | 155.9 | 30.5 | 10.9 | 90 |
| 26 | 176.1 | 32.9 | 11.2 | 90 |
| 27 | 195.9 | 35.6 | 11.7 | 90 |

| Category | Length | Height | Radius | Heading |
|----------|---------|--------|--------|---------|
| 28 | 195.6 | 36.7 | 11.6 | 90 |
| 29 | 235.6 | 40.5 | 12.5 | 90 |
| 30 | 273.6 | 51.1 | 14.7 | 90 |
| 31 | 55.6 | 18.5 | 8.4 | 90 |
| 32 | 19924.5 | 439.1 | 0 | 90 |
| 33 | 88.8 | 13.2 | 6.4 | 90 |
| 1 | 12.2 | 8 | 2.5 | 112.5 |
| 2 | 11.2 | 9.2 | 3.4 | 112.5 |
| 3 | 33.2 | 9.3 | 3.6 | 112.5 |
| 4 | 42.3 | 13.1 | 4.9 | 112.5 |
| 5 | 31.5 | 13.1 | 4.1 | 112.5 |
| 6 | 29.3 | 4.3 | 2.5 | 112.5 |
| 7 | 64.3 | 6.2 | 5 | 112.5 |
| 8 | 179.5 | 6.4 | 6.4 | 112.5 |
| 9 | 12.2 | 7.9 | 2.7 | 112.5 |
| 10 | 15.6 | 10.2 | 4.2 | 112.5 |
| 11 | 10 | 10.4 | 4.3 | 112.5 |
| 12 | 43.1 | 11.1 | 5.3 | 112.5 |
| 13 | 66.6 | 18.6 | 8.1 | 112.5 |
| 14 | 50.7 | 18.5 | 7.6 | 112.5 |
| 15 | 98.8 | 12.3 | 7.1 | 112.5 |
| 16 | 11.4 | 9 | 3.9 | 112.5 |
| 17 | 8.6 | 4.8 | 2.2 | 112.5 |
| 18 | 8.4 | 5 | 2.3 | 112.5 |
| 19 | 107.6 | 19.9 | 8.1 | 112.5 |
| 20 | 107 | 22.5 | 8.6 | 112.5 |
| 21 | 117 | 23.6 | 8.9 | 112.5 |
| 22 | 127.1 | 24.2 | 9 | 112.5 |
| 23 | 137 | 25.5 | 9.4 | 112.5 |
| 24 | 146.6 | 28.2 | 9.8 | 112.5 |
| 25 | 115.1 | 28.8 | 9.8 | 112.5 |
| 26 | 175.9 | 33.9 | 11 | 112.5 |
| 27 | 195.7 | 36.5 | 11.7 | 112.5 |
| 28 | 195.5 | 37.5 | 11.8 | 112.5 |
| 29 | 235.4 | 41.3 | 12.7 | 112.5 |
| 30 | 212.6 | 48.8 | 14.7 | 112.5 |
| 31 | 55.7 | 18.5 | 8.4 | 112.5 |
| 32 | 19924.6 | 439 | 0 | 112.5 |
| 33 | 88.9 | 11.3 | 6.6 | 112.5 |
| 1 | 7.5 | 6.2 | 2.5 | 135 |
| 2 | 11.3 | 9.2 | 3.4 | 135 |
| 3 | 28.5 | 6 | 3.1 | 135 |
| 4 | 37.5 | 10.3 | 5 | 135 |
| 5 | 26.7 | 10 | 5.4 | 135 |
| 6 | 29.4 | 4.6 | 2.4 | 135 |
| 7 | 74.4 | 6.3 | 5 | 135 |
| 8 | 219.6 | 3.4 | 6.4 | 135 |
| 9 | 12.2 | 7 | 3.3 | 135 |
| 10 | 15.8 | 10.2 | 4.9 | 135 |
| 11 | 10 | 10.4 | 4.3 | 135 |
| 12 | 43.4 | 8.3 | 4.9 | 135 |
| 13 | 61.8 | 16 | 8.2 | 135 |
| 14 | 45.9 | 15.8 | 7.7 | 135 |

| Category | Length | Height | Radius | Heading |
|----------|---------|--------|--------|---------|
| 15 | 149.2 | 6.8 | 7.1 | 135 |
| 16 | 15.9 | 10 | 3.9 | 135 |
| 17 | 72.4 | 15.2 | 7.9 | 135 |
| 18 | 76.9 | 17.6 | 8.5 | 135 |
| 19 | 108.1 | 14.4 | 8.4 | 135 |
| 20 | 107.3 | 19.6 | 9.3 | 135 |
| 21 | 117.3 | 20.6 | 9.2 | 135 |
| 22 | 127.4 | 21.2 | 9.4 | 135 |
| 23 | 137.3 | 22.5 | 9.6 | 135 |
| 24 | 146.9 | 25.3 | 10.5 | 135 |
| 25 | 146.1 | 28.8 | 11 | 135 |
| 26 | 176.2 | 31.1 | 11.4 | 135 |
| 27 | 196 | 33.8 | 12.3 | 135 |
| 28 | 195.8 | 35 | 11.9 | 135 |
| 29 | 235.7 | 38.7 | 12.9 | 135 |
| 30 | 273.7 | 50.8 | 15.3 | 135 |
| 31 | 50.9 | 17.1 | 8.5 | 135 |
| 32 | 19924.7 | 438 | 0 | 135 |
| 33 | 99 | 12.4 | 6.6 | 135 |
| 1 | 7.6 | 6.2 | 2.5 | 157.5 |
| 2 | 11.4 | 7.7 | 4.8 | 157.5 |
| 3 | 23.7 | 6.9 | 3 | 157.5 |
| 4 | 37.8 | 9.4 | 4.9 | 157.5 |
| 5 | 36.7 | 11.9 | 5.8 | 157.5 |
| 6 | 29.5 | 2.9 | 2.3 | 157.5 |
| 7 | 109.5 | 3.6 | 5 | 157.5 |
| 8 | 219.6 | -1.4 | 6.4 | 157.5 |
| 9 | 12.2 | 6.7 | 2.7 | 157.5 |
| 10 | 24.7 | 12.5 | 6.7 | 157.5 |
| 11 | 14 | 12 | 6.1 | 157.5 |
| 12 | 38.6 | 9 | 4.5 | 157.5 |
| 13 | 62.1 | 14.7 | 8.4 | 157.5 |
| 14 | 61.1 | 17.6 | 8.9 | 157.5 |
| 15 | 129 | 13.1 | 7.1 | 157.5 |
| 16 | 16 | 8 | 5.6 | 157.5 |
| 17 | 72.8 | 13.3 | 8.2 | 157.5 |
| 18 | 77.3 | 15.5 | 8.8 | 157.5 |
| 19 | 118 | 19.2 | 8.1 | 157.5 |
| 20 | 117.5 | 22 | 9 | 157.5 |
| 21 | 117.5 | 21.8 | 9.1 | 157.5 |
| 22 | 137.5 | 23.6 | 9.3 | 157.5 |
| 23 | 147.5 | 24.9 | 9.4 | 157.5 |
| 24 | 157.1 | 27.7 | 10 | 157.5 |
| 25 | 146.4 | 26.8 | 11.5 | 157.5 |
| 26 | 176.5 | 32.3 | 11.4 | 157.5 |
| 27 | 206.2 | 36.3 | 12.3 | 157.5 |
| 28 | 206 | 37.5 | 12.6 | 157.5 |
| 29 | 245.9 | 41.1 | 12.9 | 157.5 |
| 30 | 274.1 | 49.5 | 15.2 | 157.5 |
| 31 | 51.3 | 15.9 | 8.6 | 157.5 |
| 32 | 19925 | 435.1 | 0 | 157.5 |
| 33 | 109.2 | 10.7 | 6.7 | 157.5 |
| 1 | 12.3 | 7.8 | 3.6 | 180 |

| Category | Length | Height | Radius | Heading |
|----------|---------|--------|--------|---------|
| 2 | 25.5 | 14.4 | 7.3 | 180 |
| 3 | 23.7 | 6.9 | 4.9 | 180 |
| 4 | 37.7 | 11.9 | 6.9 | 180 |
| 5 | 46.6 | 16 | 8 | 180 |
| 6 | 29.5 | 4.3 | 3.6 | 180 |
| 7 | 69.3 | 7.8 | 5 | 180 |
| 8 | 179.4 | 11.9 | 6.5 | 180 |
| 9 | 12.3 | 7.7 | 4.7 | 180 |
| 10 | 49.4 | 21.8 | 11 | 180 |
| 11 | 52.2 | 26.8 | 11.5 | 180 |
| 12 | 38.4 | 9.6 | 6 | 180 |
| 13 | 62.2 | 17 | 8.5 | 180 |
| 14 | 71.1 | 21.1 | 9.3 | 180 |
| 15 | 118.7 | 15.3 | 7.1 | 180 |
| 16 | 30.4 | 15.9 | 8.7 | 180 |
| 17 | 72.6 | 16.8 | 8.1 | 180 |
| 18 | 77.1 | 19 | 8.6 | 180 |
| 19 | 107.9 | 19.3 | 8.2 | 180 |
| 20 | 107.4 | 21.4 | 8.9 | 180 |
| 21 | 117.4 | 22.6 | 8.9 | 180 |
| 22 | 127.4 | 23.4 | 9.5 | 180 |
| 23 | 147.2 | 26 | 9.7 | 180 |
| 24 | 146.9 | 27.4 | 10.2 | 180 |
| 25 | 146.3 | 30.3 | 10.9 | 180 |
| 26 | 176.3 | 33 | 11.5 | 180 |
| 27 | 196.1 | 35.6 | 11.7 | 180 |
| 28 | 195.9 | 36.7 | 12.4 | 180 |
| 29 | 235.8 | 40.6 | 12.9 | 180 |
| 30 | 284 | 53.3 | 14.9 | 180 |
| 31 | 51.4 | 18.2 | 8.7 | 180 |
| 32 | 19926.2 | 438.2 | 0 | 180 |
| 33 | 93.9 | 13.1 | 6.6 | 180 |
| 1 | 7.8 | 5.9 | 2.4 | 202.5 |
| 2 | 11.7 | 7.7 | 4.6 | 202.5 |
| 3 | 24.1 | 5.6 | 2.9 | 202.5 |
| 4 | 38.1 | 9.9 | 4.8 | 202.5 |
| 5 | 37.1 | 12.4 | 6 | 202.5 |
| 6 | 39.8 | 1.8 | 2.5 | 202.5 |
| 7 | 109.8 | 4.1 | 5.1 | 202.5 |
| 8 | 249.8 | 3.5 | 6.6 | 202.5 |
| 9 | 7.9 | 5.9 | 2.6 | 202.5 |
| 10 | 29.6 | 15 | 6.6 | 202.5 |
| 11 | 14.4 | 11.9 | 6.5 | 202.5 |
| 12 | 38.9 | 7.9 | 4.4 | 202.5 |
| 13 | 62.5 | 15.2 | 8.3 | 202.5 |
| 14 | 61.4 | 18.1 | 8.9 | 202.5 |
| 15 | 129.3 | 12 | 7.1 | 202.5 |
| 16 | 16.4 | 8.4 | 5.5 | 202.5 |
| 17 | 73 | 15.1 | 8.2 | 202.5 |
| 18 | 77.6 | 17.1 | 8.8 | 202.5 |
| 19 | 108.5 | 17 | 8.3 | 202.5 |
| 20 | 107.8 | 19.7 | 9.1 | 202.5 |
| 21 | 117.8 | 21.1 | 9.1 | 202.5 |

| Category | Length | Height | Radius | Heading |
|----------|---------|--------|--------|---------|
| 22 | 127.9 | 21.6 | 9.2 | 202.5 |
| 23 | 147.8 | 24 | 9.8 | 202.5 |
| 24 | 147.5 | 25.7 | 10.3 | 202.5 |
| 25 | 156.6 | 29.9 | 11.1 | 202.5 |
| 26 | 176.8 | 31.2 | 11.3 | 202.5 |
| 27 | 196.6 | 33.9 | 12.2 | 202.5 |
| 28 | 196.4 | 34.9 | 12.4 | 202.5 |
| 29 | 236.2 | 38.9 | 13 | 202.5 |
| 30 | 274.5 | 50 | 15.2 | 202.5 |
| 31 | 51.6 | 16.6 | 8.5 | 202.5 |
| 32 | 19926 | 435.7 | 0 | 202.5 |
| 33 | 109.4 | 10.3 | 6.5 | 202.5 |
| 1 | 7.8 | 5.9 | 2.4 | 225 |
| 2 | 6.8 | 7.2 | 3.1 | 225 |
| 3 | 29.1 | 5.1 | 2.6 | 225 |
| 4 | 38.1 | 9.5 | 4.8 | 225 |
| 5 | 27.4 | 9.4 | 5.2 | 225 |
| 6 | 29.8 | 0.5 | 2 | 225 |
| 7 | 84.8 | -1.2 | 4.9 | 225 |
| 8 | 209.7 | 2.2 | 6.4 | 225 |
| 9 | 7.9 | 5.8 | 2.6 | 225 |
| 10 | 6.9 | 7.1 | 3.2 | 225 |
| 11 | 10.5 | 10.1 | 4.7 | 225 |
| 12 | 44 | 7.1 | 4.8 | 225 |
| 13 | 62.5 | 15 | 8.2 | 225 |
| 14 | 46.5 | 15.1 | 7.5 | 225 |
| 15 | 129.4 | 10.5 | 7 | 225 |
| 16 | 6.9 | 7.1 | 3.2 | 225 |
| 17 | 73.1 | 14.1 | 8.2 | 225 |
| 18 | 77.6 | 16.5 | 8.5 | 225 |
| 19 | 108.6 | 15 | 8.3 | 225 |
| 20 | 108 | 18.5 | 9 | 225 |
| 21 | 118 | 19.5 | 9.1 | 225 |
| 22 | 128.1 | 20.1 | 9.4 | 225 |
| 23 | 147.9 | 22.5 | 10 | 225 |
| 24 | 147.6 | 24.3 | 10.5 | 225 |
| 25 | 146.8 | 27.9 | 10.9 | 225 |
| 26 | 176.9 | 30.2 | 11.5 | 225 |
| 27 | 196.7 | 33 | 11.7 | 225 |
| 28 | 196.4 | 34.1 | 12.6 | 225 |
| 29 | 236.3 | 37.9 | 13.3 | 225 |
| 30 | 274.4 | 49.9 | 15.1 | 225 |
| 31 | 51.7 | 16.2 | 8.6 | 225 |
| 32 | 19925.5 | 439.2 | 0 | 225 |
| 33 | 129.5 | 7.5 | 6.6 | 225 |
| 1 | 12.6 | 7.3 | 2.5 | 247.5 |
| 2 | 11.6 | 8.7 | 3.3 | 247.5 |
| 3 | 29.2 | 5.3 | 2.6 | 247.5 |
| 4 | 8.6 | 4.9 | 2.6 | 247.5 |
| 5 | 27.4 | 10.2 | 3.7 | 247.5 |
| 6 | 19.8 | 0.6 | 1.9 | 247.5 |
| 7 | 49.7 | -1.7 | 4.6 | 247.5 |
| 8 | 119.6 | -4.1 | 6.3 | 247.5 |

| Category | Length | Height | Radius | Heading |
|----------|---------|--------|--------|---------|
| 9 | 12.7 | 7.3 | 2.6 | 247.5 |
| 10 | 11.6 | 8.7 | 4.3 | 247.5 |
| 11 | 10.2 | 10.1 | 4.5 | 247.5 |
| 12 | 44.1 | 7.1 | 4.9 | 247.5 |
| 13 | 8.6 | 4.9 | 2.6 | 247.5 |
| 14 | 51.5 | 16.9 | 7.1 | 247.5 |
| 15 | 149.6 | 6.3 | 7.1 | 247.5 |
| 16 | 11.8 | 8.5 | 3.9 | 247.5 |
| 17 | 73.2 | 14.5 | 8 | 247.5 |
| 18 | 77.6 | 17.1 | 8.5 | 247.5 |
| 19 | 108.7 | 14.7 | 8.3 | 247.5 |
| 20 | 108 | 18.6 | 8.9 | 247.5 |
| 21 | 118 | 19.5 | 9.1 | 247.5 |
| 22 | 128.2 | 19.7 | 9.4 | 247.5 |
| 23 | 148 | 22.2 | 9.8 | 247.5 |
| 24 | 147.7 | 24.3 | 10.2 | 247.5 |
| 25 | 146.8 | 28.2 | 11.3 | 247.5 |
| 26 | 177 | 30.4 | 11.4 | 247.5 |
| 27 | 196.8 | 33.1 | 12.2 | 247.5 |
| 28 | 196.5 | 34.3 | 12.3 | 247.5 |
| 29 | 236.4 | 38 | 13 | 247.5 |
| 30 | 264.5 | 49.6 | 14.9 | 247.5 |
| 31 | 41.1 | 15.5 | 7.6 | 247.5 |
| 32 | 19925.7 | 438.8 | 0 | 247.5 |
| 33 | 129.6 | 4 | 6.6 | 247.5 |
| 1 | 12.4 | 7.4 | 2.6 | 270 |
| 2 | 11.4 | 8.8 | 3.4 | 270 |
| 3 | 29 | 5.2 | 2.8 | 270 |
| 4 | 8.4 | 5.1 | 2.5 | 270 |
| 5 | 22.4 | 8.8 | 3.5 | 270 |
| 6 | 19.7 | 0.8 | 2 | 270 |
| 7 | 49.6 | -1.7 | 4.6 | 270 |
| 8 | 119.6 | -4.1 | 6.3 | 270 |
| 9 | 12.5 | 7.3 | 2.7 | 270 |
| 10 | 11.5 | 8.7 | 4.1 | 270 |
| 11 | 10.1 | 10.1 | 4.3 | 270 |
| 12 | 43.9 | 7 | 5 | 270 |
| 13 | 8.5 | 5.1 | 2.5 | 270 |
| 14 | 46.4 | 15.8 | 6.9 | 270 |
| 15 | 149.5 | 6.6 | 7.1 | 270 |
| 16 | 11.6 | 8.5 | 3.9 | 270 |
| 17 | 78 | 15.2 | 7.9 | 270 |
| 18 | 8.7 | 4.7 | 2.4 | 270 |
| 19 | 108.6 | 14.7 | 8.4 | 270 |
| 20 | 107.9 | 18.5 | 9.2 | 270 |
| 21 | 117.9 | 19.5 | 9.3 | 270 |
| 22 | 128 | 19.7 | 9.2 | 270 |
| 23 | 147.9 | 22.2 | 10 | 270 |
| 24 | 147.5 | 24.3 | 10.3 | 270 |
| 25 | 146.6 | 28.3 | 11.3 | 270 |
| 26 | 176.8 | 30.4 | 11.3 | 270 |
| 27 | 196.6 | 33.2 | 12.4 | 270 |
| 28 | 196.3 | 34.4 | 12.2 | 270 |

| Category | Length | Height | Radius | Heading |
|----------|---------|--------|--------|---------|
| 29 | 236.3 | 38.1 | 12.9 | 270 |
| 30 | 203.5 | 45.4 | 13.8 | 270 |
| 31 | 56.4 | 18 | 8.3 | 270 |
| 32 | 19925.4 | 439.1 | 0 | 270 |
| 33 | 119.6 | 3.5 | 6.6 | 270 |
| 1 | 12.5 | 7.4 | 2.6 | 292.5 |
| 2 | 11.5 | 8.8 | 3.4 | 292.5 |
| 3 | 29.1 | 5.2 | 2.7 | 292.5 |
| 4 | 8.5 | 5.1 | 2.6 | 292.5 |
| 5 | 22.5 | 8.7 | 3.7 | 292.5 |
| 6 | 19.7 | 0.7 | 1.9 | 292.5 |
| 7 | 49.7 | -1.9 | 4.5 | 292.5 |
| 8 | 169.7 | -2 | 6.3 | 292.5 |
| 9 | 12.5 | 7.3 | 2.7 | 292.5 |
| 10 | 11.5 | 8.7 | 4.3 | 292.5 |
| 11 | 10.1 | 10.1 | 4.4 | 292.5 |
| 12 | 44 | 7 | 4.9 | 292.5 |
| 13 | 8.5 | 5.1 | 2.6 | 292.5 |
| 14 | 51.4 | 16.9 | 7 | 292.5 |
| 15 | 149.6 | 5.3 | 7.1 | 292.5 |
| 16 | 11.7 | 8.5 | 4 | 292.5 |
| 17 | 73.1 | 14.4 | 7.9 | 292.5 |
| 18 | 77.5 | 17.1 | 8.5 | 292.5 |
| 19 | 108.7 | 14.6 | 8.3 | 292.5 |
| 20 | 108 | 18.5 | 9 | 292.5 |
| 21 | 118 | 19.4 | 9.1 | 292.5 |
| 22 | 128.1 | 19.7 | 9.4 | 292.5 |
| 23 | 148 | 22.1 | 10 | 292.5 |
| 24 | 147.6 | 24.2 | 10.2 | 292.5 |
| 25 | 146.7 | 28.3 | 11.3 | 292.5 |
| 26 | 176.9 | 30.3 | 11.4 | 292.5 |
| 27 | 196.7 | 33.1 | 12.4 | 292.5 |
| 28 | 196.4 | 34.3 | 12.2 | 292.5 |
| 29 | 236.4 | 38 | 13 | 292.5 |
| 30 | 203.5 | 46.2 | 13.8 | 292.5 |
| 31 | 56.6 | 17.8 | 8.3 | 292.5 |
| 32 | 19925.4 | 439 | 0 | 292.5 |
| 33 | 119.7 | 2.8 | 6.5 | 292.5 |
| 1 | 7.8 | 6 | 2.4 | 315 |
| 2 | 6.8 | 7.2 | 3.1 | 315 |
| 3 | 29.1 | 5 | 2.6 | 315 |
| 4 | 33.3 | 8.3 | 4.7 | 315 |
| 5 | 27.4 | 9.3 | 5.2 | 315 |
| 6 | 29.8 | 0.2 | 2 | 315 |
| 7 | 74.8 | -1.3 | 4.8 | 315 |
| 8 | 199.8 | 0.8 | 6.4 | 315 |
| 9 | 8 | 5.7 | 2.6 | 315 |
| 10 | 6.9 | 7.1 | 3.1 | 315 |
| 11 | 10.5 | 10.1 | 4.7 | 315 |
| 12 | 44.1 | 6.9 | 4.8 | 315 |
| 13 | 62.5 | 14.9 | 8.2 | 315 |
| 14 | 46.6 | 15 | 7.5 | 315 |
| 15 | 139.4 | 10.5 | 7.1 | 315 |

| Category | Length | Height | Radius | Heading |
|----------|---------|--------|--------|---------|
| 16 | 7 | 7 | 3.2 | 315 |
| 17 | 73.2 | 13.9 | 8.1 | 315 |
| 18 | 77.7 | 16.3 | 8.8 | 315 |
| 19 | 108.7 | 14.7 | 8.3 | 315 |
| 20 | 108 | 18.1 | 9.2 | 315 |
| 21 | 118 | 19.1 | 9.1 | 315 |
| 22 | 128.1 | 19.6 | 9.6 | 315 |
| 23 | 148 | 22.1 | 9.8 | 315 |
| 24 | 147.6 | 24 | 10.3 | 315 |
| 25 | 146.8 | 27.6 | 11.1 | 315 |
| 26 | 176.9 | 29.9 | 11.5 | 315 |
| 27 | 196.7 | 32.6 | 12.1 | 315 |
| 28 | 196.5 | 33.8 | 12 | 315 |
| 29 | 236.4 | 37.6 | 13 | 315 |
| 30 | 274.5 | 49.6 | 15.1 | 315 |
| 31 | 51.7 | 16.1 | 8.6 | 315 |
| 32 | 19925.6 | 438.9 | 0 | 315 |
| 32 | 129.6 | 5.4 | 6.6 | 315 |
| 1 | 7.8 | 5.9 | 2.4 | 337.5 |
| 2 | 11.7 | 7.6 | 4.6 | 337.5 |
| 3 | 24.1 | 5.5 | 2.8 | 337.5 |
| 4 | 33.3 | 8.8 | 4.7 | 337.5 |
| 5 | 37.1 | 12.2 | 5.9 | 337.5 |
| 6 | 34.8 | 1.2 | 2.3 | 337.5 |
| 7 | 109.8 | 1.3 | 5 | 337.5 |
| 8 | 239.7 | 0.6 | 6.5 | 337.5 |
| 9 | 7.9 | 5.8 | 2.6 | 337.5 |
| 10 | 29.7 | 14.9 | 6.5 | 337.5 |
| 11 | 14.4 | 11.8 | 6.1 | 337.5 |
| 12 | 39 | 7.6 | 4.3 | 337.5 |
| 13 | 62.6 | 15.2 | 8.4 | 337.5 |
| 14 | 61.5 | 17.9 | 8.9 | 337.5 |
| 15 | 129.4 | 10.6 | 7.1 | 337.5 |
| 16 | 16.4 | 8.4 | 5.5 | 337.5 |
| 17 | 73.1 | 14.8 | 8.2 | 337.5 |
| 18 | 77.7 | 16.8 | 8.8 | 337.5 |
| 19 | 108.5 | 16.4 | 8.3 | 337.5 |
| 20 | 107.9 | 19.3 | 9 | 337.5 |
| 21 | 118 | 20.5 | 9.4 | 337.5 |
| 22 | 128 | 21 | 9.2 | 337.5 |
| 23 | 147.9 | 23.4 | 9.9 | 337.5 |
| 24 | 157.5 | 26.5 | 10.1 | 337.5 |
| 25 | 156.7 | 29.5 | 11.1 | 337.5 |
| 26 | 176.9 | 30.8 | 11.8 | 337.5 |
| 27 | 196.7 | 33.5 | 12.2 | 337.5 |
| 28 | 196.5 | 34.5 | 12.5 | 337.5 |
| 29 | 236.4 | 38.4 | 13 | 337.5 |
| 30 | 274.6 | 49.6 | 15.2 | 337.5 |
| 31 | 51.7 | 16.3 | 8.5 | 337.5 |
| 32 | 19926.1 | 435.1 | 0 | 337.5 |
| 33 | 109.5 | 9 | 6.6 | 337.5 |

APPENDIX C

Horizon Curvature Calculations

Minimum Plume Rise

Describes the condensation plume rise height necessary for it to be visible from the observation point

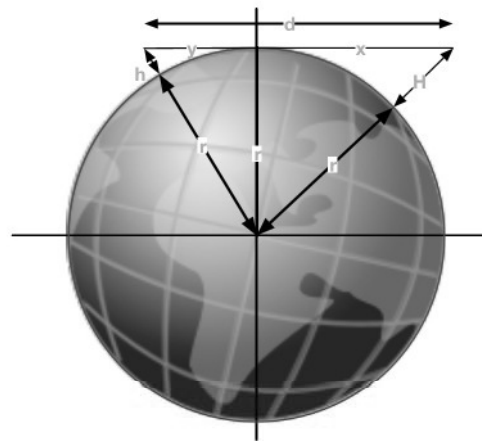
| | |
|---|--|
| h | Height of the observation point (known) |
| H | Visible height of the target (unknown) |
| r | radius of earth |
| d | distance between the observation point and the cooling tower |
| J | Distance between the observation point and the target |
| y | Viewable horizon distance (Calculated) |
| x | Distance from the horizon to the target (unknown) |

Solve for Horizon intercept

$$y^2 + r^2 = (h + r)^2$$

$$y^2 = (h^2 + 2hr + r^2) - r^2$$

$$y = \sqrt{h^2 + 2hr} \quad \text{Equation 1}$$



Solve for H

$$J = (H + r) \quad \text{Definition}$$

$$x^2 + r^2 = J^2 \quad \text{Substitution}$$

$$J = \sqrt{x^2 + r^2}$$

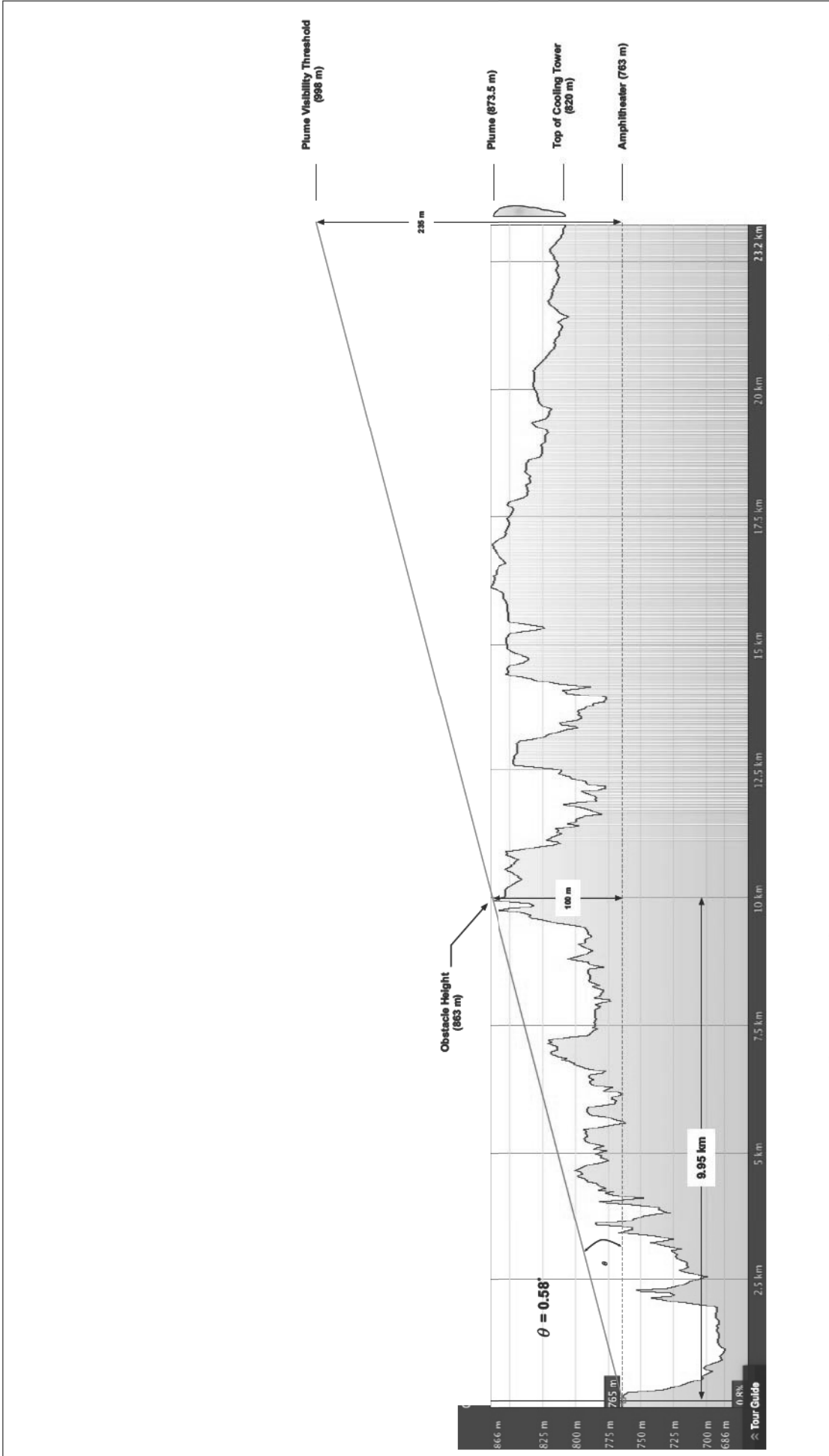
$$(H + r) = \sqrt{x^2 + r^2} \quad \text{Solve for H}$$

$$H = \sqrt{x^2 + r^2} - r \quad \text{Substituting the definition of distance (d)}$$

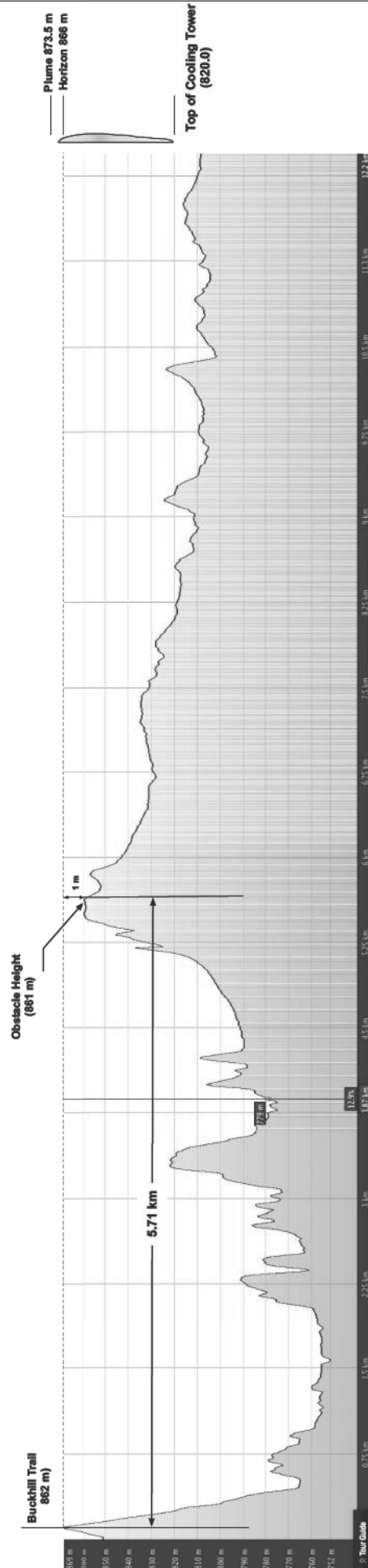
$$H = \sqrt{(d - y)^2 + r^2} - r \quad \text{Equation 2}$$

APPENDIX D

Plume Visibility Figures



| | | |
|--|--|--|
| <p>Zia Engineering & Environmental Consultants, LLC 241 N. Chouteau St., Suite 300 Pierre, SD 57501 Phone: (605) 660-2300 Fax: (605) 538-7887</p> | <p>Figure Name: THEODORE ROOSEVELT NATIONAL PARK AMPHITHEATER</p> | <p>Project No.: NHOE-16-001</p> |
| | <p>Project Name: NORTH DAKOTA DAVIS REFINERY VISIBILITY STUDY</p> | <p>Date: MARCH 2017</p> |
| | | <p>Figure No.: 1</p> |

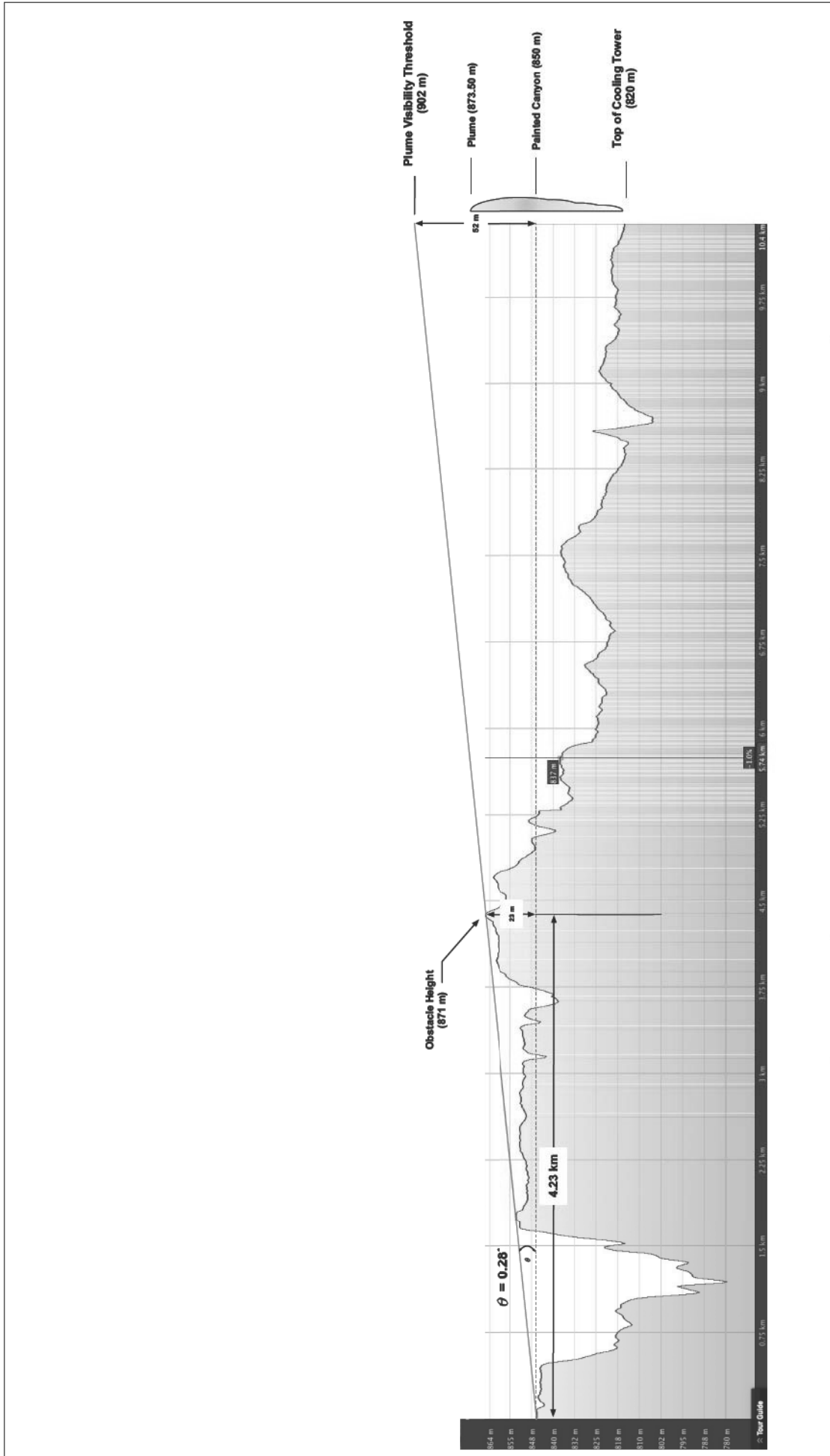


Zia Engineering & Environmental Consultants, LLC
 241 N. Chappel St., Suite 500
 Phone: (578) 660-2300 6801
 Fax: (578) 532-7887

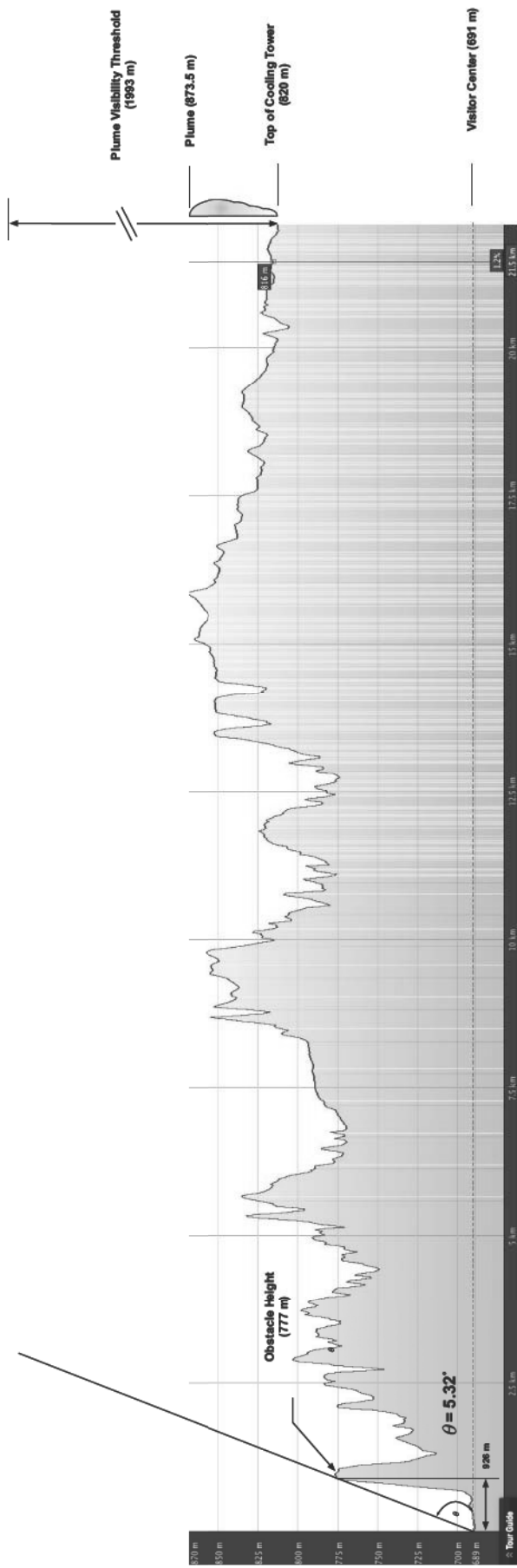


Figure Name: BUCKHILL TRAIL OBSERVATION POINT
Project Name: NORTH DAKOTA DAVIS REFINERY VISIBILITY STUDY

Project No.: NHOE-16-001
Date: MARCH 2016
Figure No.: 1



| | | |
|--|---|---|
| <p>Zia Engineering & Environmental Consultants, L.L.C. Jay R. Chappell, L.L.M., Suite 500 Phone: (578) 660-2300 6801 Fax: (578) 532-7287</p> | <p>Figure Name: PAINTED CANYON VISITOR CENTER</p> <p>Project Name: NORTH DAKOTA DAVIS REFINERY VISIBILITY STUDY</p> | <p>Project No.: NHOE-16-001</p> <p>Date: MARCH 2017</p> <p>Figure No.: 1</p> |
|--|---|---|



Zia Engineering & Environmental Consultants, L.L.C.
 2417 N. Chippewa St., Suite 300
 Fargo, ND 58103
 Phone: (701) 660-2300
 Fax: (701) 660-2387

Figure Name: THEODORE ROOSEVELT NATIONAL PARK VISITOR CENTER
Project Name: NORTH DAKOTA DAVIS REFINERY VISIBILITY STUDY

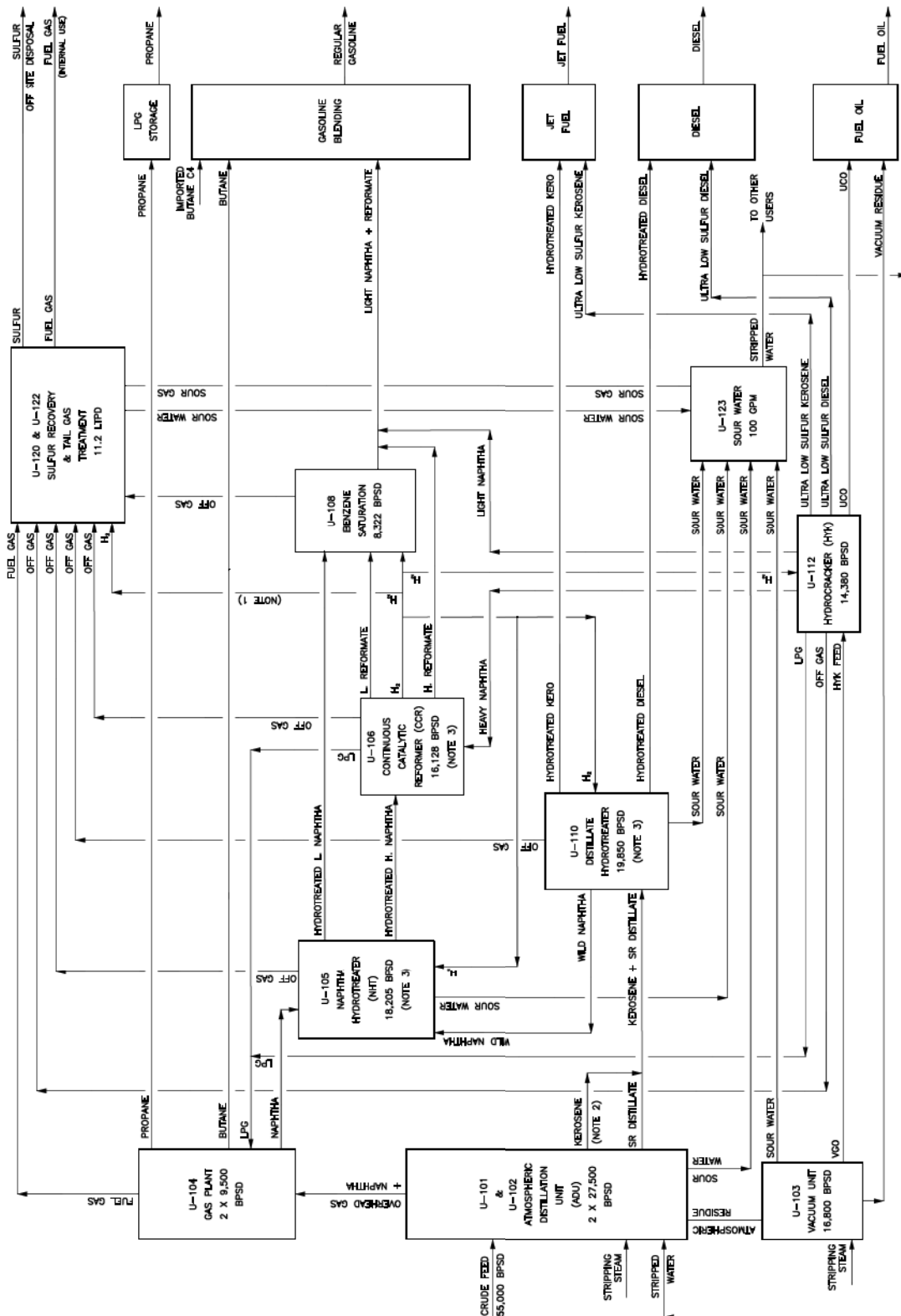
Project No.: NHOE-16-001
Date: MARCH 2017
Figure No.: 1



Exhibit E: Process Block Diagrams

NOTES:

1. H₂ RICH GAS FROM CONTINUOUS CATALYTIC REFORMER IS DIRECTLY SENT TO NAPHTHA HYDROTREATER, DIESEL HYDROTREATER, BENZENE SATURATION UNIT, AND HYDROCRACKER. BALANCE GAS IS SENT TO FUEL GAS SYSTEM.
2. TO ACHIEVE WINTER GRADE ULSD SPECIFICATION, PARTIAL OR TOTAL KEROSENE STREAM MUST BE BLENDED INTO DIESEL VIA DIESEL HYDROTREATER UNIT.
3. UNIT CAPACITIES ARE BASED ON THE NAME PLATE CAPACITY AND BAKEN CRUDE ASBAY.
4. BLOCK FLOW DIAGRAM FOR PERMITTING PURPOSE ONLY.



MERIDIAN DAVIS REFINERY
PERMITS SUPPORT

BLOCK FLOW DIAGRAM
DAVIS REFINERY

VEPICA PROJECT NO. P-4716043-01
SHEET 1 OF 1

DATE: 08/20/2014
TIME: 10:00:00 AM

SCALE: NONE
TBD

PROJECT NO. P-4716043-01
SHEET 1 OF 1

| REV. | DATE | BY | CHK | APP. | NO. | DESCRIPTION |
|------|------------|----------|----------|------|-----|--------------------------------|
| 1 | 08/20/2014 | J.L. CUL | M.L. CUL | | 1 | ISSUED FOR PERMIT TO CONSTRUCT |
| 2 | 08/20/2014 | J.L. CUL | M.L. CUL | | 2 | ISSUED FOR AMENDMENT TO PTC |

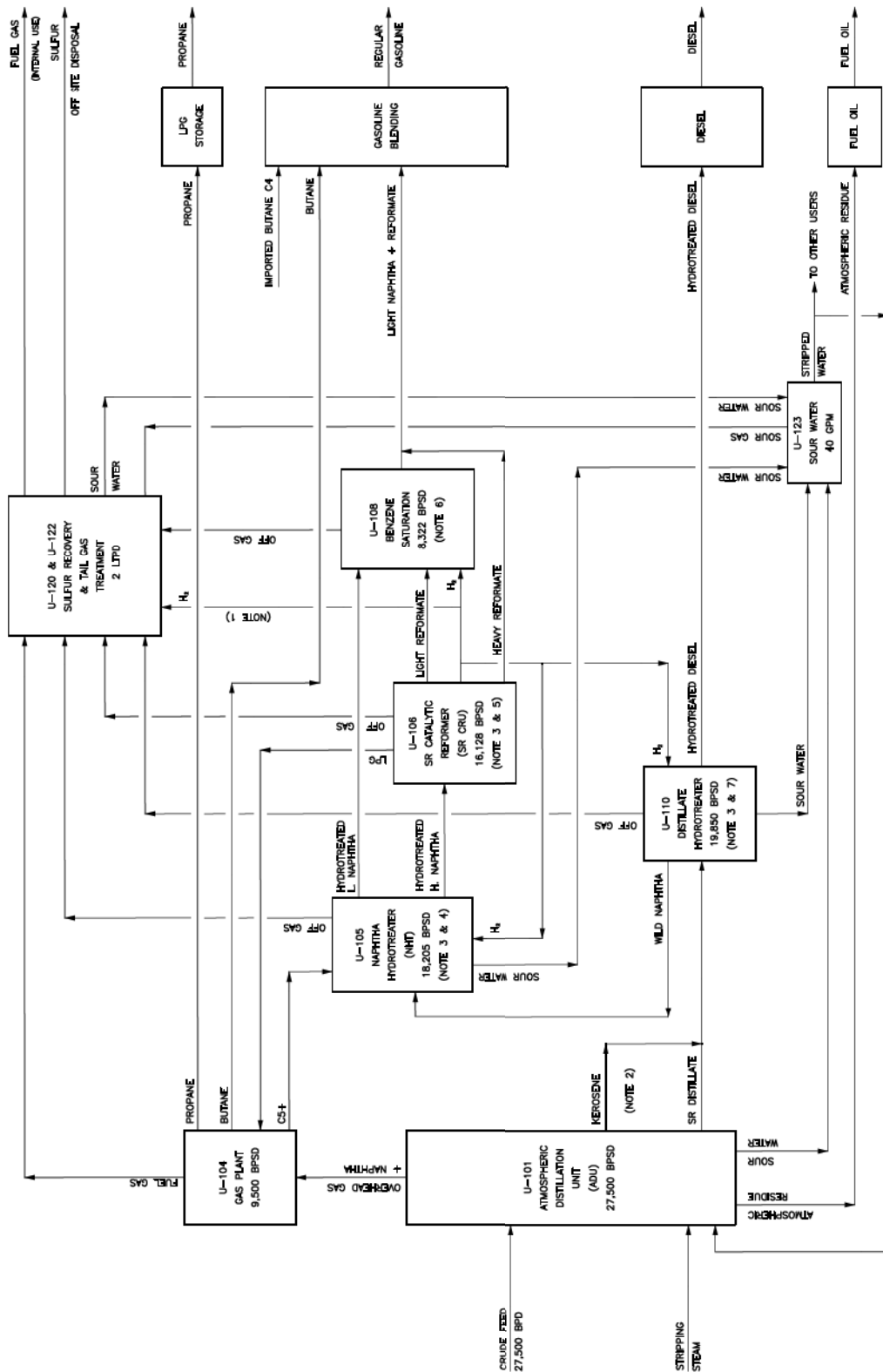
| ENGINEER'S RECORD | NAME | DATE |
|-------------------|--------------|----------|
| DESIGNED | M. POWER | 08/20/14 |
| CHECKED | A. THOMAS | 08/20/14 |
| APPROVED | C. HARRIS | 08/20/14 |
| DATE | 08/20/14 | |
| PROJECT NO. | P-4716043-01 | |
| SCALE | NONE | |
| SHEET | 1 | |
| TOTAL SHEETS | 1 | |

| REFERENCE DRAWINGS | DESCRIPTION |
|--------------------|-------------|
| | |

C 34" x 22"

NOTES:

- H₂ RICH GAS FROM SR CATALYTIC REFORMER IS DIRECTLY SENT TO NAPHTHA HYDROTREATER, DIESEL HYDROTREATER, AND BENZENE SATURATION UNIT. BALANCE GAS IS SENT TO FUEL GAS SYSTEM.
- TO ACHIEVE WINTER GRADE ULSD, SPECIFICATION, KEROSENE STREAM MUST BE BLENDED INTO DIESEL, VIA DIESEL HYDROTREATER UNIT.
- UNIT CAPACITIES ARE BASED ON THE NAME PLATE CAPACITY AND BAKKEN CRUDE ASSAY.
- NAPHTHA HYDROTREATER OPERATING CAPACITY DURING PHASE 1 = 0,103 BPSD
- SR CATALYTIC REFORMER OPERATING CAPACITY DURING PHASE 1 = 5,028 BPSD
- BENZENE SATURATION UNIT OPERATING CAPACITY DURING PHASE 1 = 3,797 BPSD
- DIESEL HYDROTREATER OPERATING CAPACITY DURING PHASE 1 = 9,763 BPSD



Meridian Energy Group Inc.
vepica

Meridian Davis Refinery
Permits Support

Block Flow Diagram
Davis Refinery Phase 1

| REV. | No. | DATE | DESCRIPTION |
|------|-----|----------|--------------------------------|
| 1 | 1 | 02/11/17 | ISSUED FOR PERMIT TO CONSTRUCT |
| 2 | 1 | 02/11/17 | REVISED FOR AMENDMENT TO PDC |

| ENGINEER'S RECORD | DATE | NAME | APP. | CHK. | BY | DESCRIPTION |
|-------------------|----------|--------------|------|------|----|-------------|
| DESIGNED | 02/11/17 | M. PETER | | | | |
| CHECKED | 02/11/17 | A. LINDS | | | | |
| APPROVED | 02/11/17 | P. J. GIBSON | | | | |

| REFERENCE DRAWING NO. | DESCRIPTION |
|-----------------------|-------------|
| | |

| REV. | No. | DATE | DESCRIPTION |
|------|-----|----------|--------------------------------|
| 1 | 1 | 02/11/17 | ISSUED FOR PERMIT TO CONSTRUCT |
| 2 | 1 | 02/11/17 | REVISED FOR AMENDMENT TO PDC |

| ENGINEER'S RECORD | DATE | NAME | APP. | CHK. | BY | DESCRIPTION |
|-------------------|----------|--------------|------|------|----|-------------|
| DESIGNED | 02/11/17 | M. PETER | | | | |
| CHECKED | 02/11/17 | A. LINDS | | | | |
| APPROVED | 02/11/17 | P. J. GIBSON | | | | |

| SCALE | DATE | BY | DESCRIPTION |
|-------|------|----|-------------|
| NONE | TBD | | |

C 34" x 22"

Exhibit F: Site Plan

