



Demicks Lake Pipeline Project

CONSTRUCTION MITIGATION AND RESTORATION PLAN

DRAFT

Prepared by:



December 2018

This page intentionally left blank

ONEOK DEMICKS LAKE PIPELINE PROJECT
CONSTRUCTION MITIGATION AND RESTORATION PLAN
TABLE OF CONTENTS

INTRODUCTION	1
1.0 GENERAL MITIGATION MEASURES.....	2
1.1 RIGHT-OF-WAY ACCESS	2
1.2 RIGHT-OF-WAY REQUIREMENTS	2
1.3 FLAGGING AND SIGNAGE	3
1.4 LINE LIST AND PERMITS	4
1.5 NON-HAZARDOUS WASTE DISPOSAL	4
1.5.1 Hazardous Wastes.....	5
1.6 TEMPORARY EROSION AND SEDIMENT CONTROLS	5
1.7 UPLAND CLEARING	5
1.7.1 Disposal of Woody Debris	6
1.7.2 Upland Grading and Stump Removal.....	6
1.7.3 Irrigation Systems.....	6
1.7.4 Upland Topsoil Segregation	7
1.7.5 Temporary Erosion and Sediment Controls	8
1.7.6 Temporary Slope Breakers	9
1.7.7 Noise and Dust Control	10
1.8 PIPE DELIVERY, BENDING, & WELDING	10
1.9 UPLAND TRENCHING	10
1.9.1 Timing.....	11
1.9.2 Pipeline Depth	11
1.10 PIPE INSTALLATION	11
1.11 TRENCH BREAKERS	11
1.12 UPLAND BACKFILLING	11
1.13 WET WEATHER SHUTDOWN	12
1.14 CONTROLLING SPREAD OF UNDESIRABLE SPECIES	12
1.15 CLEANUP AND ROUGH/FINAL GRADING	13
1.16 TIMING	13
1.17 PERMANENT EROSION AND SEDIMENT CONTROLS	13
1.18 SOIL COMPACTION TREATMENT	14

1.19	ROCK REMOVAL	14
1.20	OFF-ROAD VEHICLE CONTROL MEASURES	14
1.21	REPAIR OF DAMAGED CONSERVATION PRACTICES	14
1.22	LAND LEVELING FOLLOWING CONSTRUCTION	14
2.0	STREAM AND RIVER CROSSING GENERAL REQUIREMENTS	15
2.1	DRAINAGE DITCHES AND EPHEMERAL/ INTERMITTENT STREAMS	15
2.2	TIME WINDOW FOR CONSTRUCTION	15
2.3	AGENCY NOTIFICATION	16
2.4	PRE-CONSTRUCTION CONSIDERATIONS	16
	2.4.1 Hazardous Materials	16
	2.4.2 Refueling/Equipment Care	16
	2.4.3 Aquatic Invasive Species Considerations	16
2.5	CLEARING AND GRADING	16
2.6	WORKSPACE AND EXTRA WORKSPACE	17
2.7	BRIDGES AND EQUIPMENT CROSSING	17
	2.7.1 Types of Bridges	17
	2.7.2 Bridge Design and Maintenance	18
2.8	STREAM AND RIVER CROSSING CONSTRUCTION METHODS	18
	2.8.1 Wet Trench Method	18
	2.8.2 Dam and Pump Method	19
	2.8.3 Flume Method	20
	2.8.4 Horizontal Directional Drill (HDD) Method	21
2.9	PERMANENT RESTORATION	22
	2.9.1 Vegetative Bank Restoration	23
	2.9.2 Rock Riprap Restoration	23
	2.9.3 Bridge Removal	23
	2.9.4 Swales	23
	2.9.5 Drainage Ditches and Intermittent Streams	23
3.0	WETLAND CROSSING GENERAL REQUIREMENTS	23
3.1	WETLAND ACCESS	24
3.2	SPILL PREVENTION	24
	3.2.1 Storage of Fuels and Other Materials	24
	3.2.2 Refueling, Fuel Handling, and Equipment Maintenance	24

3.3	CLEARING	24
3.4	EXTRA WORKSPACE IN WETLANDS	25
3.5	GRADING IN A WETLAND	25
3.6	CONSTRUCTION MATTING	25
3.7	TRENCHING	26
3.8	TOPSOIL SEGREGATION	26
3.9	TRENCH BREAKERS	26
3.10	PIPELINE INSTALLATION	26
	3.10.1 Push/Pull Method	26
3.11	TEMPORARY EROSION AND SEDIMENT CONTROLS	26
3.12	BACKFILLING	27
3.13	ROUGH GRADING, CLEANUP, AND TEMPORARY RESTORATION	27
	3.13.1 Timing.....	27
	3.13.2 Temporary Stabilization.....	27
4.0	HIGHWAY, ROAD, and RAIL CROSSINGS.....	28
4.1	EXTRA WORKSPACE	28
4.2	MAINTENANCE	28
4.3	TEMPORARY EROSION AND SEDIMENT CONTROLS	28
5.0	CONSTRUCTION DEWATERING.....	28
5.1	TRENCH DEWATERING	28
	5.1.1 Regulatory Notification and Reporting.....	29
	5.1.2 Flow Measurement.....	29
	5.1.3 Water Sampling.....	29
6.0	HYDROSTATIC TESTING.....	29
6.1	SITING OF TEST MANIFOLDS	30
7.0	WATER APPROPRIATION SOURCES AND DISCHARGE LOCATIONS.....	30
7.1	APPROPRIATION FLOW MEASUREMENT	30
7.2	TEST WATER DISCHARGE	30
	7.2.1 Discharge Flow Measurement.....	31
	7.2.2 Discharge Water Sampling.....	31
7.3	REGULATORY NOTIFICATION AND REPORTING	31
8.0	REVEGETATION.....	32

LIST OF TABLES

Table 1.3-1	ONEOK Demicks Lake Pipeline Project Signs.....	4
-------------	--	---

LIST OF FIGURES¹

Figure 1	Typical Construction Layout
Figure 2	Typical Construction Layout on Sloping Terrain
Figure 3	Typical Silt Fence Installation
Figure 4	Typical Straw Bale Installation
Figure 5	Typical Topsoil Segregation – Full Right-of-Way
Figure 6	Typical Temporary Berms – Perspective View
Figure 7	Typical Temporary or Permanent Berms – Elevation View
Figure 8	Typical Trench Breakers – Perspective View
Figure 9	Typical Trench Breakers – Plan and Profile Views
Figure 10	Permanent Slope Breakers – Perspective View
Figure 11	Erosion Control Blanket – Steep Slopes ($\geq 30\%$)
Figure 12	Typical Waterbody Crossing – Wet Trench Method
Figure 13	Typical Waterbody Crossing – Dam and Pump Method
Figure 14	Typical Waterbody Crossing – Flume Method
Figure 15	Typical Waterbody Crossing – Directional Drill Method
Figure 16	Typical Span Type Bridge with and without In-Stream Support (Timber Mat Bridge)
Figure 17	Typical Rock and Flume Bridge
Figure 18	Typical Dewatering Measures
Figures 19-21	Typical Straw Bale Dewatering Structure
Figure 22	Typical Final Stream Bank Stabilization – Rip Rap & Erosion Control
Figure 23	Typical Wetland Crossing
Figure 24	Typical Improved Road Crossing-Directional Bore

¹ Site-specific plans supersede any design presented in the typical details.

LIST OF ACRONYMS

ATWS	Additional Temporary Workspace
BMPs	Best Management Practices
CFR	Code of Federal Regulations
CMRP	Construction Mitigation and Restoration Plan
ECD	Temporary Erosion and Sediment Control Device
ETWS	Extra Temporary Workspace
HDD	Horizontal Directional Drill
LIDAR	Light Detection and Ranging
NPDES	National Pollutant Discharge Elimination System
ONEOK	ONEOK Bakken Pipeline, L.L.C.
Project	ONEOK Demicks Lake Pipeline Project
ROW	Right-of-Way
SPCC Plan	Spill Prevention, Control, and Countermeasure Plan or Spill Plan
TWS	Temporary Workspace

INTRODUCTION

ONEOK Bakken Pipeline, L.L.C. (ONEOK) is committed to meeting or exceeding all applicable federal, state, and local environmental requirements during the planning, construction, and operation of the ONEOK Demicks Lake Pipeline Project (hereby referred to as the Project). ONEOK has developed this Construction Mitigation and Restoration Plan (CMRP) to ensure that appropriate systems are in place to achieve compliance with the various permits and plans that have been developed for the project. ONEOK's CMRP outlines construction-related environmental policies, procedures, and mitigation measures developed by ONEOK based on ONEOK's experience implementing Best Management Practices (BMPs) during pipeline construction. The CMRP is designed to address typical circumstances that may be encountered along the Project. Project-specific permit conditions and/or landowner agreements may supersede the general practices described in this document.

This document includes the following sections:

- Section 1.0 of the CMRP describes general mitigation measures, including soil erosion and sedimentation control procedures, to be implemented during upland construction and upland restoration;
- Section 2.0 discusses stream and river construction and restoration;
- Section 3.0 describes practices for wetland construction and restoration;
- Section 4.0 discusses highway, road, and rail crossings;
- Section 5.0 discusses construction dewatering;
- Section 6.0 outlines hydrostatic testing practices;
- Section 7.0 addresses water appropriation sources and discharge locations;
- Section 8.0 addresses revegetation.

Alternative construction procedures implemented in lieu of this CMRP must provide an equal or greater level of protection to the environment and must be approved in writing by ONEOK.

1.0 GENERAL MITIGATION MEASURES

1.1 RIGHT-OF-WAY ACCESS

Access to the right-of-way (ROW) will be from public roadways and ONEOK-approved private access roads only. The Contractor is responsible for creating signs or other methods to identify approved access roads in the field and to ensure that access is confined to the approved roads.

Road crossings and access points will be maintained in a safe and accessible condition throughout construction. ONEOK will require its construction contractor(s) to post caution signs on roads, where appropriate, to alert motorists of pipeline construction and warn them of slow traffic. In addition, trucks transporting pipe and heavy equipment will comply with all applicable state, county, and federal laws, rules, and permits for these loads.

Private/non-public roads will be negotiated with the landowner and approved by ONEOK prior to use. Use of these roads may be restricted based on the condition of the existing road (i.e., like-use traffic) and may not be upgraded without approval from ONEOK, the landowner, and/or applicable regulatory agencies.

Vehicle tracking of soil from the construction site onto roads will be minimized by implementation of BMPs such as installing stone pads, timber mats, or equivalent, and reducing equipment/vehicle access to the ROW where practicable (through the use of off-ROW parking). Temporary accesses will be installed in accordance with applicable permit conditions. The Contractor is responsible to promptly clean and remove all soil from tracked out of the ROW on to public roads and highways.

The Contractor will repair private roads, lanes, and public roads damaged when moving equipment or obtaining access to the ROW.

1.2 RIGHT-OF-WAY REQUIREMENTS

Construction equipment and vehicles will be confined to the approved construction ROW, access roads, and extra workspace (approved construction workspace) shown on the "Issued for Construction" construction alignment sheets. Construction activities for the Project will generally use a 75-foot-wide construction ROW as shown in Figure 1 that consists of the permanent ROW and temporary workspace (TWS). In addition, certain site-specific extra workspaces as defined below will be utilized. The construction ROW configuration may be modified to avoid and/or minimize disturbance to sensitive resource areas such as wetlands and waterways or difficult construction areas such as steep side slopes and/or in accordance with applicable permit conditions.

Permanent ROW

ONEOK will establish a new 50-foot-wide permanent easement, centered on the new pipeline. The new permanent ROW will be maintained in an herbaceous or shrub vegetative cover following construction to facilitate access and inspection and operation of the pipeline system.

Temporary Workspace

In addition to the new permanent ROW, construction will require temporary workspace (TWS). The TWS will be located adjacent to and contiguous with the proposed ROW/permanent corridor and will typically be 25 feet wide. Approved TWS will be identified on the construction alignment sheets and by distinctive staking of construction limits prior to clearing.

Extra/Additional Workspace

Site-specific extra temporary workspace (ETWS) and/or additional temporary workspace (ATWS) locations are construction work areas beyond the permanent ROW and TWS described above and will be required at select locations such as steep slopes as shown in Figure 2, road, waterbody, railroad, some wetland crossings, and where it is necessary to cross under existing pipelines or foreign utilities. ATWS will typically be located in uplands adjacent to the construction ROW and set 50 feet back from sensitive resource boundaries where site-specific field conditions allow. However, to complete work safely, ONEOK may need to locate ATWS within a wetland or within the 50-foot setback from a wetland or waterbody based on site-specific conditions. ATWS adjacent to waterbodies and/or wetlands is addressed further in Sections 2.6 and 3.4, respectively. In all cases, the size of extra workspace will be kept to the minimum necessary to safely conduct work.

ONEOK has conducted a preconstruction review of the entire Project area to determine specific ATWS locations. ONEOK will acquire extra workspace from the landowner where necessary. All approved ATWS locations are depicted on the construction alignment sheets; use of unauthorized workspace is prohibited without ONEOK's written approval.

Pipe Storage and Contractor Yards

ONEOK and its contractors will establish pipe and contractor yards at various locations near the Project ROW. The best practices and procedures that ONEOK has approved in the CMRP, as well as all applicable permits, will be implemented as necessary at these locations.

1.3 FLAGGING AND SIGNAGE

Prior to the commencement of clearing operations, ONEOK will mark the boundaries of the approved construction workspace with distinctive stakes and flagging. ONEOK will install stakes to identify the boundaries of ATWS, staging areas, sensitive environmental areas, and along the construction ROW every 200 feet, or as appropriate, to maintain line-of-sight from one stake to the next. Other areas (pipe storage and contractor yards, borrow and disposal areas, access roads, etc.) will have signs posted for use by the Contractor during construction activities. See Table 1.3-1 for examples of the signs that will be installed on the Project.

ONEOK will preserve all existing recognizable civil survey monuments, cadastral corner markers, witness points, triangulation stations, military control monuments, or other recognizable physical markers (public and private) to the extent practicable. In the event that any such monument is at risk of damage or destruction during construction, ONEOK will ensure that the precise location of the monument is determined and properly referenced by a Professional Land Surveyor. If the monument is actually damaged or destroyed during construction, it will be rehabilitated or replaced by the Professional Land Surveyor. The monument will be replaced in accordance with the requirements of the State Board which oversees Professional Land Surveying.

Signs will be posted along the construction ROW to identify sensitive areas and to alert construction personnel of restrictions that apply. The limits of these areas will be delineated at the edge of the ROW. Fencing may also be required in some areas to further protect site-specific resources.

**TABLE 1.3-1
ONEOK Demicks Lake Pipeline Project Signs**

Sign	Description
Approved Access Road	Project-related right-of-way access roads will be identified by road number or name and posted speed limit.
No Access	Signs identifying areas that are off limits, such as a fork in the road, which may be confused with Approved Access Areas.
Environmentally Sensitive Areas	Signs identifying environmentally sensitive areas that are off limits to disturbance or may require a special resource monitor during construction.
Waterbody	Entry and exits at delineated waterbodies.
Wetland	Entry and exits at delineated wetlands.

ONEOK has identified landowner-specific issues of concern that may be affected by construction activities. In coordination with these landowners, ONEOK will implement the following mitigation measures:

- Locate and mark above and below ground water lines;
- Locate and mark above and below ground utilities;
- Coordinate with landowners that utilize pivot irrigation systems; and
- Develop grazing deferment plans with landowners, tenants, or other grazing permit holders that address construction timing, fence cutting and bracing, temporary fencing, cattle guard locations, and water requirements for livestock.

Components of irrigation systems, waterlines, utilities, or other physical impediments impacted by construction will be repaired to at least pre-construction condition.

1.4 LINE LIST AND PERMITS

ONEOK will provide the Contractor with a Construction Line List (Line List). The Line List reflects special landowner requirements (e.g., topsoil segregation, seeding, fencing requirements, rock disposal, etc.); however, the Line List is not a comprehensive list of construction requirements. The Line List must be considered in conjunction with other Project documents and permits. The Contractor must comply with these special landowner requirements provided they conform to the Project permits. Any third-party agreements between the Contractor and the landowner must be pre-approved by ONEOK and in writing.

Permits obtained by ONEOK for this Project may have more stringent requirements than the requirements of this CMRP and/or the Line List. **In all cases, the more restrictive requirements will apply.**

1.5 NON-HAZARDOUS WASTE DISPOSAL

Non-hazardous pipeline construction wastes include human waste, trash, pipe banding and spacers, paper waste from coating products, welding rods, timber skids, cleared vegetation, stumps, drilling mud and rock. The contractor will be responsible for removing waste from the Project area and identifying and locating proper licensed waste disposal facilities. The Contractor will not permit paper from wrapping or coating products or lightweight items to be scattered by the wind.

Waste which contains (or at any time contained) oil, grease, solvents, or other petroleum products falls within the scope of the oil and hazardous substances control, cleanup, and disposal procedures. This material will be segregated for handling and disposal as hazardous wastes.

The Contractor will provide portable, self-contained toilets during construction operations. Wastes from these units will be collected for disposal at licensed and approved facilities.

Drill cuttings and drilling mud will be disposed of as described in Section 2.8.4 of this document.

1.5.1 Hazardous Wastes

Hazardous and potentially hazardous materials will be stored, handled, and transported in accordance with applicable laws, regulations, rules or permits. Hazardous waste materials will be stored in properly labeled containers. Each label will identify the contents in the container, indicate if the material is hazardous, and include a waste code and date of accumulation.

Personnel who will have a role in handling, storing, or otherwise managing hazardous waste will have training in accordance with applicable regulatory requirements and the manufacturer's recommendations. Personnel will be familiar with the hazards associated with particular wastes and appropriate safety procedures. Appropriate emergency response and spill equipment will be kept in an accessible area in accordance with ONEOK's Spill Prevention, Control, and Countermeasure Plan (SPCC Plan).

Transporters of oil, hazardous substances, and hazardous wastes will be licensed and certified according to the applicable state vehicle code. Hazardous wastes being transported off-site will be manifested. The manifest will conform to requirements of the appropriate state agency. The transporter will be licensed and certified to handle hazardous wastes on the public highways. The vehicles as well as the drivers must conform to all applicable vehicle codes for transporting hazardous wastes. The manifest will conform to applicable state and federal regulations.

Hazardous materials will be disposed of at licensed waste disposal facilities.

1.6 TEMPORARY EROSION AND SEDIMENT CONTROLS

Temporary sediment and erosion control devices (ECDs) include, but are not limited to slope breakers, sediment barriers, stormwater diversions, trench breakers, mulch, and revegetation. The goal of ECDs is to minimize wind and water erosion on-site and prevent construction-related sediment from migrating off-site into sensitive resource areas such as streams (dry or flowing), wetlands, lakes, or cultural resource sites. The Contractor will, at all times, maintain erosion and sediment control structures as required in the project construction documents and as required by applicable permits.

ECDs will be installed as necessary and in accordance with applicable permit conditions after initial clearing but before disturbance of the soil and will be replaced by permanent ECDs as restoration is completed (see Figures 3 and 4). Additional information on ECDs is provided in the waterbody and wetland sections (Sections 2.0 and 3.0 of this Plan) and permanent restoration is addressed in ONEOK's *Revegetation Plan*.

1.7 UPLAND CLEARING

The initial stage of construction involves the clearing of tall herbaceous vegetation, brush, and trees from the ROW. Clearing may be accomplished with mowers, chain saws, and/or other hydraulic tree and brush cutting equipment. When clearing, trees will be felled onto the ROW to minimize damage to off-ROW vegetation and resources.

1.7.1 Disposal of Woody Debris

Unless otherwise directed by ONEOK, slash and woody debris will be disposed of by mowing, chipping, grinding, and/or hauling off-site to an approved disposal facility, or the material will be stockpiled at the edge of the ROW and used to stabilize erodible slopes during restoration. Disposal of trees or merchantable timber will be conducted in accordance with landowner agreements. Where landowner approval has been granted, chips may be uniformly broadcast (less than 2-inch thickness) across the ROW in non-agricultural, non-wetland areas, where they will ultimately be incorporated into the topsoil layer during grading activities. Burning of woody debris may be allowed only where the Contractor has acquired all applicable permits and approvals (e.g., agency and landowner) and in accordance with all state and local regulations. The Contractor will provide ONEOK with copies of these permits and/or approvals prior to initiating burning.

Burning will not be allowed within 100 feet of a wetland or waterbody without site-specific approval from ONEOK. No burning will be allowed in wetlands. No chips, mulch, or mechanically cut woody debris will be stockpiled in a wetland and no upland woody debris will be disposed of in a wetland or within agricultural areas (see Section 3.3 for further information on clearing in a wetland).

1.7.2 Upland Grading and Stump Removal

Grading generally follows clearing and involves leveling and smoothing the construction ROW and extra workspace areas (as necessary) to create a safe, even working surface for equipment and vehicles. Topsoil and subsoil disturbed during grading operations will not be mixed with foreign material (e.g., stumps and brush).

The objective of grading is to develop a ROW that allows the safe passage of equipment and meets the bending limitations of the pipe. The following measures will be implemented during grading unless otherwise approved or directed by ONEOK based on site-specific conditions or circumstances.

- Original contours and drainage patterns will be re-established to the extent practicable.
- Agricultural areas that have terraces will be surveyed to establish pre-construction contours to be utilized for restoration of the terraces after construction.
- Gravel access pads or timber mats will be used where necessary to prevent damage to the road shoulder and bar ditch at roadways to be crossed during construction.
- Where the construction surface remains inadequate to support equipment travel, timber mats, timber riprap, or other methods may be used to stabilize surface conditions.

1.7.3 Irrigation Systems

If pipeline construction activities interfere with the operation of existing spray irrigation systems (flood, ditch, or spray), ONEOK will establish with the landowner or tenant, an acceptable amount of time the irrigation system may be out of service with the landowner or tenant. If feasible, temporary measures will be implemented to allow an irrigation system to continue to operate across the ROW during pipeline construction. Damage to irrigation systems caused by construction-related activities will be repaired following backfilling. Irrigation ditches that are active at the time of construction will not be stopped or obstructed except for the length of time necessary to install the pipeline beneath the ditch unless otherwise approved by the landowner or applicable ditch authority.

1.7.4 Upland Topsoil Segregation

The objective of topsoil handling is to maintain topsoil capability by conserving topsoil for future replacement and reclamation and to minimize the degradation of topsoil from compaction, rutting, loss of organic matter, or soil mixing so that successful reclamation of the ROW can occur. Topsoil generally has physical and chemical properties that are conducive to good plant growth. To prevent the mixing of topsoil with less productive subsoil during construction, topsoil will be segregated to avoid the co-mingling of soils, using the full right-of-way topsoiling method (see Figure 5). Separation should be maintained between the topsoil and subsoil piles throughout construction to prevent mixing. Upland areas where topsoil will be stripped include cropland, hay fields, pasture, residential areas, and other areas as agreed to by the landowner or as specified in the Project permits. Topsoil will not be used to construct trench breakers (see Section 1.11) or to pad the pipe or construct ramps. Gaps must be left and ECDs installed where stockpiled topsoil and spoil piles intersect with water conveyances (i.e., ditches, swales, and waterways) to maintain natural drainage and to allow wildlife access across the construction work area. Wildlife gaps (including the water conveyance gaps) will be installed at a minimum of every quarter-mile.

The following mitigation measures will be implemented during topsoil removal and storage. All work will be conducted in accordance with applicable permits.

- Stockpile stripped topsoil in a windrow along the edge of the ROW. The Contractor will perform work in a manner to minimize the potential for subsoil and topsoil to be mixed.
- Topsoil will not be used to fill a low area or to construct ramps at road or waterbody crossings.
- If required due to excessively windy conditions, topsoil piles can be tackified using either water or a suitable approved tackifier (liquid mulch binder). Further details are included in the ONEOK *Dust Control Plan*.

Topsoil Segregation Methods

The Full ROW topsoil segregation method (see Figure 5) will be employed during construction, as indicated on the “Issued for Construction” (IFC) alignment sheets.

Soil characteristics and land use are key considerations for topsoil management during pipeline construction. ONEOK will primarily use the full ROW topsoil stripping method, unless otherwise requested by the landowner. In arid areas with a limited topsoil resource, and/or in areas where significant side-slope excavation (e.g., two-toned, side-cut, etc.) will be required to create a safe, level area. In these areas, topsoil will typically be segregated using an excavator, dozer, or similar equipment.

Depth of Upland Topsoil Stripping

The depth of topsoil to be segregated will depend on the soil conditions. In areas of deep topsoil, stripping to a maximum depth of 12 inches will generally be considered adequate to minimize impacts on agricultural soils. Additional workspace may be needed for spoil storage if more than 12 inches of topsoil are segregated. If less than 12 inches of topsoil are present, the Contractor will attempt to segregate to the depth that is present. The Environmental Inspectors and ONEOK will work with the Contractor to determine topsoil depth to be stripped.

1.7.5 Temporary Erosion and Sediment Controls

Erosion Control Devices

ECDs are intended to minimize erosion by slowing the velocity of stormwater runoff and diverting runoff from the construction ROW, preventing the movement of sediments off the construction ROW, and prohibiting the deposition of sediments into sensitive resources that may be on or adjacent to the ROW. Typical ECDs include silt fence and/or trenched-in and staked straw bales (see Figures 3 and 4) or biologs (i.e., compost socks, wattles, or excelsior logs), as well as other barriers such as compacted earth (e.g., drivable berms across travel ways), sand bags, or other appropriate materials (see Section 1.7.6).

Temporary ECDs will be installed after clearing and prior to grubbing and grading activities at the base of sloped approaches to streams, wetlands, and roads. Temporary ECDs will also be installed at the edge of the ROW as needed, and/or in other areas determined by ONEOK to slow water leaving the site and prevent siltation of waterbodies and wetlands downslope or outside of the construction ROW (e.g., swales and side slopes). Temporary ECDs will be placed across the entire construction ROW at the base of slopes greater than 5 percent where the base of the slope is less than 50 feet from drainage ways, wetlands, and/or waterbodies until the area is revegetated in accordance with the National Pollutant Discharge Elimination System (NPDES) stormwater permit (where applicable) and there is no potential scouring or sediment transport to surface waters.

If silt fence is in use, when the depth of sediment reaches about one-half of the height, the sediment will be removed. Non-functional ECDs will be repaired, replaced, or supplemented with functional structures, as required by the NPDES storm water permit.

Temporary ECDs installed across the travel lane may be removed during active daytime construction; however, the ECDs will be properly reinstalled after equipment passage, or activities in the area are completed for the day. These ECDs will also be repaired and/or replaced prior to forecasted inclement weather. The Contractor is responsible for monitoring weather conditions and adjusting resources as needed to address pending and/or existing weather conditions.

Temporary Stabilization

Temporary stabilization is intended to minimize erosion of soil from wind and water. Installation of temporary seeding, mulch, and erosion control mats/blankets may be required by ONEOK in site-specific locations if there are construction delays within a spread and/or there is a high potential for erosion to occur. The Contractor may be required by ONEOK to install temporary stabilization materials based on site conditions, or as required in ONEOK's Project specific NPDES permit(s). Temporary stabilization measures as outlined in ONEOK's *Revegetation Plan* will be implemented to minimize erosion and for sediment control.

ONEOK will attempt to stabilize exposed slopes prior to snowfall; however, construction progress and/or seasonal weather variations may prevent installation prior to the first snowfall in some locations. Installation of stabilization measures and additional BMPs, as applicable based on site conditions, will continue after the first snowfall to protect slopes prior to spring melt and runoff.

Mulch

Mulch is an effective tool to minimize erosion and will be applied to disturbed areas (except for actively cultivated land and wetlands) if agreed to with the landowner or land managing agency, if specified by the applicable permits or licenses, or as requested by ONEOK.

Mulch will be free of noxious weeds as listed in applicable state laws. Certified weed-free mulch may also be required at site-specific locations. The contractor(s) will be responsible for identifying and acquiring sources of certified weed-free mulch. Sources must be approved by ONEOK prior to purchase and copies of the applicable documentation must be provided to ONEOK.

Mulch will be applied at 1-2 tons per acre unless otherwise stipulated by permit conditions. Mulch will be uniformly distributed by a mechanical mulch blower, or by hand in areas not accessible to the mulch blower, to cover approximately 75 percent of the ground surface. Strands of mulch will be a minimum of 8 inches in length to allow proper anchoring. Mulch will be anchored/crimped to a depth of 2-3 inches using a mulch-anchoring tool or disc set in the straight position to minimize loss by wind and water. In areas not accessible to a mulch-anchoring tool, the mulch may be anchored by liquid tackifiers, with advance written approval from ONEOK. The manufacturer's recommended method and rate of application will be followed. Mulch will not be applied in wetlands or actively cultivated farmland.

Hydro-mulch and liquid tackifier may be used in place of straw or weed-free hay mulch with prior approval from ONEOK. Application rates will be at the manufacturer's recommended rate, equal to or greater than 2 tons per acre of straw mulch. The use of tackifiers for anchoring straw and the use of hydro-mulch and tackifier will be limited to areas that are too steep or rocky to safely or effectively operate mechanical mulch-anchoring tools. Asphalt-based tackifiers will not be used on the Project.

1.7.6 Temporary Slope Breakers

Temporary slope breakers will be installed to minimize concentrated or sheet flow runoff in disturbed areas in accordance with the following maximum allowable spacing unless otherwise specified in permit conditions. Temporary slope breakers will also be installed on slopes greater than 5 percent where the base of the slope is less than 50 feet from waterbodies, wetlands, and road crossings. The spacing between temporary slope breakers may be reduced based on site-specific conditions, as requested by ONEOK.

<u>Slope (%)</u>	<u>Approximate Spacing (ft.)</u>
5-15	300
15-30	200
>30	≤100

If the length of the slope is less than the distance of the required spacing, slope breakers will not be required unless a sensitive resource area (e.g., wetland) is located immediately down slope, or as requested by ONEOK. Temporary slope breakers may be constructed using earthen subsoil material, silt fence, straw bales, or biologs; rocked trenches may only be used in non-agricultural land. On highly erodible slopes, temporary slope breakers in the form of either earthen berms or rocked trenches will be used whenever possible.

Temporary slope breakers will be constructed according to the following specifications:

- Earthen berms will be installed with a 2 to 4 percent outslope, with a minimum 4-foot base and a minimum height of 1.5 feet (see Figures 6 and 7);
- Straw bales used as slope breakers will be trenched in and staked tightly against one another as to not allow flow underneath or between the bales;
- The outfall of temporary slope breakers will be directed off the construction ROW into a stable well-vegetated upland area or into an appropriate energy-dissipating sediment control device (e.g., silt fence, straw bales, rock aprons) to prevent the discharge of sediments (see Figure 6);
- Proper slope breaker outfalls will be established where topsoil segregation and/or grading has created a barrier at the edge of the construction workspace;
- Gaps will be created through spoil piles where necessary to allow temporary berms to direct flow off-ROW;
- The outfall of each temporary slope breaker will be positioned to prevent sediment discharge into wetlands, waterbodies, or other sensitive resources; and
- Temporary slope breakers will be inspected and repaired as necessary to maintain operational integrity and prevent erosion in active construction areas.

1.7.7 Noise and Dust Control

The Contractor will take reasonable steps to control construction-related noise near residential areas and other noise sensitive areas as directed by ONEOK. Noise control practices may include limiting working hours and vehicle traffic in residential areas and/or additional measures as appropriate based on site-specific conditions. Dust control practices are detailed in ONEOK's *Dust Control Plan*.

1.8 PIPE DELIVERY, BENDING, & WELDING

Individual joints of pipe will be strung along the construction ROW. This operation involves specially designed equipment to deliver pipe from pipe storage yards to the ROW. Where practical, the Contractor will drive stringing trucks along an alignment which corresponds closely to the pipeline centerline to minimize the potential for soil compaction in actively cultivated areas.

After pipe stringing is complete, the pipe will be bent, as necessary, to conform to changes in ground contours and pipeline alignment. Individual pipe joints will be welded together, and the welds will be inspected using a non-destructive testing procedure to verify weld integrity, in accordance with federal regulations. The welds will then be coated to protect them from corrosion.

1.9 UPLAND TRENCHING

Trenching in uplands consists of excavating the trench for the pipeline and is typically accomplished with a backhoe excavator or a rotary wheel ditching machine. Excavated material will be sidecast (stockpiled) within the approved construction ROW separate from topsoil (see Section 1.7.4) and stored such that erosion is minimized to the extent practicable. During construction ONEOK will coordinate with landowners to minimize disruption of access caused by the trench. Where agreed to, the Contractor will leave plugs of soil in the ditch or will construct temporary access bridges across the trench for the landowner to move livestock or equipment. Trenches will also be sloped where started and ended to allow ramps for wildlife to escape.

1.9.1 Timing

The length of time a trench is left open will be minimized to ensure that installation of the pipe and restoration of the ROW occurs in a timely fashion.

1.9.2 Pipeline Depth

At a minimum, the pipeline will be buried in accordance with U.S. Department of Transportation (USDOT) regulations (49 Code of Federal Regulations (CFR) Part 195) to prevent damage to the pipeline from normal use of the land.

1.10 PIPE INSTALLATION

Once the trench has been inspected for proper depth, rocks, and/or other obstructions, the welded pipe will be lowered into the trench. In rocky soils, the pipe may be wrapped with a protective shielding to prevent damage to the pipe coating during backfilling.

1.11 TRENCH BREAKERS

Trench breakers are installed in sloped areas after the pipeline has been lowered into the trench to protect against subsurface water flow along the pipe after the trench is backfilled. Trench breakers will be constructed with bags filled with rock-free subsoil or sand. Topsoil **may not** be used for trench breakers. Trench breakers will be placed from the bottom of the trench to near the top of the trench, completely surrounding the pipe, **and must be properly keyed into the undisturbed trench walls** (see Figures 8 and 9). The location for trench breakers will be based on field conditions including the degree and length of slope, presence of down slope sensitive resource areas such as wetland and waterbodies, and proximity to other features such as roads and/or railroads. The following conditions apply to the placement and installation of trench breakers unless otherwise directed by ONEOK:

- Trench breakers will be spaced as described for permanent berms (see Section 1.17) or as otherwise specified by ONEOK.
- Trench breakers will be installed on slopes greater than 5 percent adjacent to streams, wetlands, or other waterbodies.
- At a minimum, trench breakers will be installed at the base of slopes greater than 5 percent where the base of the slope is less than 50 feet from a waterbody or wetland and where needed to avoid draining a waterbody or wetland.
- Topsoil will not be used to construct trench breakers.
- Where the pipeline exits a wetland towards areas of lower relief, trench breakers will be installed where there is a potential for underground drainage along the pipe in order to prevent wetland or waterbody drainage.

ONEOK will identify preliminary trench breaker locations on the Project alignment sheets. These locations will be based on a review of mapped resources and topographical maps. The actual location of each trench breaker will be selected through coordination between ONEOK's Craft Inspectors, and the Contractor's Foreman during backfilling activities.

1.12 UPLAND BACKFILLING

Backfilling follows pipe installation and consists of replacing the material excavated from the trench. In many cases fine material will be needed to pad the pipe. Topsoil cannot be used as padding material

under any circumstance. In areas where topsoil has been segregated, the subsoil will be replaced first, and then the topsoil will be spread uniformly over the area from which it was removed. Prior to backfilling, the trench will be dewatered in accordance with the methods discussed in Section 5.0 of this Plan. Rock excavated from the trench may be used to backfill the trench only to the top of the existing bedrock profile. Rock that is not returned to the trench should be considered construction debris and be removed to an approved disposal site, unless approved for use as mulch, for another acceptable construction-related purpose, or as designated by the landowner or land managing agency.

1.13 WET WEATHER SHUTDOWN

During construction, certain activities may be suspended at the direction of the Project Construction Coordinator in wet soil conditions, based on consideration of the following factors:

- Plasticity of the surface soil to a depth of approximately 4 to 8 inches;
- Extent of surface ponding;
- Extent and depth of rutting and mixing of soil horizons;
- Areal extent and location of potential rutting and compaction (i.e., can traffic be rerouted around wet area, using low ground weight, wide-track equipment, or other low impact construction techniques, using construction mats in problem areas); and
- Type of equipment and nature of the construction operations proposed for that day.

If, in consideration of the above factors, ONEOK determines that construction activities will result in significant rutting and/or the mixing of soil horizons, the Contractor will cease work in the applicable area until ONEOK determines that site conditions are such that work may continue.

The Contractor is responsible for appropriately planning for work, considering the potential for wet conditions, and being prepared to implement mitigation measures in the event of wet weather conditions. This is particularly important when conducting work in unsaturated wetlands or areas where topsoil was not segregated. The Contractor is responsible for implementing any and all such corrective measures should conditions subsequently worsen where the above-described criteria cannot be met.

1.14 CONTROLLING SPREAD OF UNDESIRABLE SPECIES

It is ONEOK's intent to minimize the potential introduction and/or spread of undesirable species (i.e., invasive species and noxious weeds) along its ROW due to pipeline construction activities. However, it is not practicable for ONEOK to eradicate undesirable species that are adjacent to its ROW. ONEOK will minimize the potential for the establishment of undesirable species by minimizing the time between final grading and permanent seeding. Greater than six days is only acceptable if final grading had to take place outside of the seeding window, as described in the *Revegetation Plan* or in the Contractor's ONEOK-approved revegetation plan.

ONEOK will implement weed control measures, pending landowner approval, at identified infestation areas based on weed district input, or by the EIs. Weed control measures may include the application of herbicide or mechanical, and/or alternative methods. The weed control measure chosen will be the best method available for the time, place, and species of weed as identified through consultation with the appropriate regulatory agencies. Should landowners not allow the use of herbicides, alternative methods, approved by the landowners, will be implemented.

ONEOK will also require that construction equipment and timber mats be free of soil and plant material before arriving on the construction spread, as well as be cleaned at state and county lines, to prevent the introduction of undesirable species to the project area, as described in the project's *Weed Management Plan*.

1.15 CLEANUP AND ROUGH/FINAL GRADING

Initial cleanup and rough grading activities may take place simultaneously. Cleanup involves removing construction debris (e.g., litter generated by construction crews, timber skids and similar woody debris, and excess rock).

Rough and final grading includes restoring disturbed areas as near as practicable to preconstruction conditions, returning the topsoil where topsoil has been stripped, preparing a seedbed (where applicable) for permanent seeding, installing or repairing temporary erosion and sediment control measures, repairing/replacing fences, and installing permanent erosion and sediment controls. Pre-existing landowner soil conservation improvements and structures disturbed by pipeline construction will be restored to the approximate pre-construction line and grade. Soil conservation improvements and structures include, but are not limited to, grassed waterways, toe walls, drop inlets, grade control works, terraces, levees, and farm ponds.

1.16 TIMING

The Contractor will begin cleanup and rough grading (including installation of temporary erosion and sediment control measures) typically within 72 hours after backfilling and will attempt to complete this cleanup within fourteen (14) days after backfilling, weather and soil conditions permitting. If seasonal or other weather conditions prevent compliance with the time frames, the contractor will maintain the erosion and sediment control measures until cleanup can be conducted.

1.17 PERMANENT EROSION AND SEDIMENT CONTROLS

During final grading, slopes in areas other than cropland will be stabilized with erosion control structures (see Figure 11). Erosion control treatments of specific physical land features are described below.

Slopes

Permanent berms (diversion dikes or slope breakers) will be installed on slopes, according to the following maximum spacing requirements unless otherwise specified in permit conditions or determined in the field by ONEOK:

<u>Slope (%)</u>	<u>Approximate Spacing (ft.)</u>
5-15	300
15-30	200
>30	≤100

Permanent berms will be constructed according to the following specifications:

- Permanent berms will be installed with a 2 to 4 percent outslope and will not cause pooling of water behind the berm.
- Permanent berms will be constructed of compacted earth.

- The outfall of berms will be directed toward appropriate energy-dissipating devices, and off the construction ROW if possible.
- Permanent berms will be inspected and repaired as deemed necessary by ONEOK to maintain function and prevent erosion.
- Erosion control blankets will be placed on slopes over 30 percent (see Figure 11) or that are a continuous slope to a sensitive resource area (e.g., wetland or waterway).
- There should be no unbroken slope length greater than 75 feet for slopes with a grade of 3:1 or steeper in order to maintain sheet flow and minimize rills and/or gullies.

1.18 SOIL COMPACTION TREATMENT

Cultivated fields and compacted or rutted cultivated areas will be tilled with a deep tillage device or chisel plowed to loosen compacted soils. Severely compacted agricultural areas will be plowed with a paraplow or other deep tillage implement. In areas where topsoil has been segregated, the subsoil will be plowed before replacing the segregated topsoil. If subsequent construction and cleanup activities result in further compaction, additional measures will be undertaken to alleviate the soil compaction.

Topsoil and subsoil will be tested at regular intervals in agricultural and residential areas. The Environmental Inspectors will conduct tests on the same soil type under similar moisture conditions in undisturbed areas to approximate preconstruction conditions. Penetrometers or other appropriate devices to conduct tests.

1.19 ROCK REMOVAL

Excess rock will be removed from at least the top 12 inches of disturbed soil in all actively cultivated or rotated cropland and pastures, hayfields, and residential areas or as specified in permit conditions or landowner agreements. Rock removal efforts will cease when the size and density of rocks on the ROW are similar to undisturbed areas adjacent to the ROW. Excess rock will be piled in upland areas where landowner permission has been obtained or will be hauled off-site to a ONEOK-approved disposal site.

1.20 OFF-ROAD VEHICLE CONTROL MEASURES

Off-road vehicle control measures will be installed as agreed to with landowners or as directed by land management agencies at points of entry. Such measures may include installing signs, fences and gates, or placement of other barriers such as boulders or timbers. All fences and gates removed or damaged will be repaired or replaced. The contractor may be held responsible for damage caused by trespassers if proper deterrent structures were not in place in a timely fashion.

1.21 REPAIR OF DAMAGED CONSERVATION PRACTICES

Soil conservation practices (such as terraces, grassed waterways, etc.) that are damaged by the pipeline construction will be restored to preconstruction conditions to the extent practicable.

1.22 LAND LEVELING FOLLOWING CONSTRUCTION

Following the completion of the pipeline, the ROW will be restored as near as practicable to its pre-construction conditions. Should uneven settling or documented surface drainage problems occur following the completion of pipeline construction, ONEOK will take appropriate steps to remedy the issue.

Permanent revegetation activities will begin as soon as soil conditions permit seedbed preparation and seed germination. Actively cultivated lands will be restored but will not be reseeded unless requested by the landowner. See Section 8.0 for more information regarding reseeding.

2.0 STREAM AND RIVER CROSSING GENERAL REQUIREMENTS

Pre-construction planning is an essential part of stream crossings. Stream crossing requirements, including construction methods, timing, erosion control, and restoration are described in this section and in the stream crossing permits issued by state and federal agencies. Prior to construction, the Contractor may identify alternative provisions to certain site-specific plans that would provide an equal or greater level of protection to stream and river ecosystems. Any proposed alternative provisions must be submitted to ONEOK far enough in advance of construction to allow ONEOK an opportunity to review the alternatives and consult with the appropriate regulatory agencies as necessary without causing construction delays. The Contractor must receive written approval from ONEOK prior to implementing the alternative crossing techniques.

The procedures in this section apply to natural or artificial streams, rivers, and other waterbodies such as jurisdictional ditches, ponds, and lakes. These procedures require that judgment be applied in the field and will be implemented under the supervision of ONEOK. The intent of the mitigation procedures is to minimize construction-related disturbance to waterbodies by limiting the duration of construction in these areas and by minimizing erosion and sedimentation, as well as implementing appropriate procedures to restore the stream to pre-construction conditions.

ONEOK is proposing to avoid all streams and wetlands that would trigger a Preconstruction Notification (PCN) with the Army Corps of Engineers (USACE/Corps). ONEOK will accomplish this by either routing around PCNs or by using a Horizontal Directional Drill (HDD) or conventional bore methods. Locations that would otherwise require a PCN will be identified in the field and on the alignment sheets as Environmentally Sensitive Areas (ESAs). Mitigation and avoidance measures at ESAs are described throughout Sections 2.0 and 3.0.

2.1 DRAINAGE DITCHES AND EPHEMERAL/ INTERMITTENT STREAMS

Ephemeral/Intermittent streams and agricultural ditches that are not identified as ESAs will typically be crossed using the wet trench method (see Section 2.8.1), as specified in the applicable permits. For ephemeral streams; small, dry intermittent streams; and agricultural drainage ditches, standard upland construction procedures may be used, which involve stringing, welding, excavating the trench with backhoes, installing the pipe in the trench, and backfilling the trench with native material unless stipulated otherwise in the Project's applicable permits. Extra workspace setbacks will be implemented in accordance with Section 2.6. The banks of each crossing will be reshaped to pre-construction contours, mulched, and, if required, seeded in accordance with ONEOK's *Revegetation Plan* to stabilize the crossing until permanent erosion control is implemented. No refueling, fuel storage, or equipment maintenance is allowed within 100 feet of a drainage ditch or intermittent stream without approval from ONEOK with additional special provisions for containment. Where dry swales cross the ROW, silt fence or straw bales will be installed at the edge of the ROW to prevent the flow of sediment off the approved construction workspace.

2.2 TIME WINDOW FOR CONSTRUCTION

In-stream trenching will be conducted during periods permitted by the appropriate regulatory agencies and applicable permits. In-stream trenching is not permitted at ESAs.

2.3 AGENCY NOTIFICATION

ONEOK will notify applicable regulatory agencies as well as authorities responsible for potable surface water supply intakes located within three (3) miles downstream of the crossing prior to beginning in-stream work (e.g., excavation or blasting), in accordance with applicable permit conditions or as otherwise specified by that authority. Installation or removal of bridges is not considered in-stream work for the purpose of notifying agencies of nearby public surface water intakes.

2.4 PRE-CONSTRUCTION CONSIDERATIONS

2.4.1 Hazardous Materials

Hazardous materials, chemicals, fuels, and lubricating oils will not be stored, and concrete coating activities will not be performed within 100 feet of waterbodies and in accordance with ONEOK's *SPCC Plan*. Refer to the *SPCC Plan* for additional requirements pertaining to hazardous materials.

2.4.2 Refueling/Equipment Care

Construction equipment will be refueled at least 100 feet from streams and waterbodies. Where the Contractor and ONEOK determine that conditions require construction equipment to be refueled within 100 feet of streams, the Contractor must follow the procedures described in ONEOK's *SPCC Plan* and implement additional provisions based on site-specific conditions. No equipment will be washed within 100 feet of waterbodies. Overnight parking of equipment is not allowed within 100 feet of a waterbody unless special provisions have been implemented in accordance with ONEOK's *SPCC Plan* and prior approval from ONEOK is obtained. Repair and maintenance (e.g., lubricating) of construction equipment will not be allowed within the 100-foot buffer zone without approval from ONEOK with additional special provisions for containment. The Contractor will ensure that all equipment is free of leaks prior to use on the Project and prior to entering or working in or near waterbodies.

2.4.3 Aquatic Invasive Species Considerations

The states of Montana and North Dakota have no specific regulations in relation to Aquatic Invasive Species; therefore, there are no unique considerations regarding aquatic invasive species for this project at this time.

2.5 CLEARING AND GRADING

The Contractor will leave a 20-foot buffer of undisturbed herbaceous vegetation on all stream banks during initial clearing, except where grading is needed for bridge installation, or where restricted by applicable regulations and/or permit conditions (such as impaired waterways), or where the buffer would prevent safe equipment operation. Woody vegetation within this buffer may be cut and removed during clearing, leaving the stumps and root structure intact. Non-woody vegetation and the soil profile will be left intact until the Contractor is ready to begin trenching the crossing. This buffer should not be confused with the 50-foot setback required for extra workspace (see Section 2.6).

Sediment barriers will be promptly installed and properly maintained at waterbody crossings and waterbodies adjacent to the construction ROW in accordance with the Project's state-specific *Stormwater Pollution Prevention Plan (SWPPP)* until replaced by permanent erosion controls or restoration of adjacent upland areas is complete.

2.6 WORKSPACE AND EXTRA WORKSPACE

The permanent easement, temporary workspace, ATWS, and any special restrictions are depicted on the construction drawings.

Extra workspaces, as defined in Section 1.2, include work areas outside the boundary of the typical construction ROW. These spaces are typically used to assemble pipe segments, stage additional equipment or materials for the crossing, and for temporary spoil storage. Clearing of forested and brushy areas for extra workspace will be avoided as much as possible. Woody vegetation in wetlands and riparian areas will typically not be cleared for the purpose of extra workspace unless approved by appropriate regulatory agencies as stipulated in permits issued for the Project. Clearing of woody vegetation is never permitted at an ESA. Extra workspaces will be constructed as follows:

- Extra workspaces will be located 50 feet away from the water's edge where topographic or other physical conditions such as stream channel meanders allow (see Figures 14-16).
- If safe work practices or site conditions do not allow for a 50-foot setback, extra workspaces should be located as far from the water's edge as site-specific conditions allow.
- Extra workspaces will be limited to the minimum size needed to safely and efficiently construct the stream crossing.

2.7 BRIDGES AND EQUIPMENT CROSSING

Temporary bridges may be installed in certain locations to allow construction equipment to cross perennial waterbodies. Bridges may also be installed at intermittent waterbodies flowing at the time of construction, or those which have a high probability of flowing during construction. Intermittent waterbodies may cause saturated conditions, which would increase the probability of rutting. Bridges may include clean rock fill over culverts, timber mats supported by flumes, railcar flatbeds, and flexi-float apparatus, as described below and will be removed as soon as practical during final restoration. Construction equipment will be required to use the bridges, except the clearing crew and equipment necessary for installation of equipment bridges, which will be allowed a single pass across waterbodies prior to bridge installation, unless restricted by applicable permits.

An equipment bridge is only permitted at ESAs if the site-specific ESA plan calls for one, if it is clear-span (no in-stream supports), and it is above the ordinary high water mark (OHWM).

2.7.1 Types of Bridges

Equipment bridges will be constructed using one of the following techniques:

- Timber mats (clear-span and in-stream support - see Figure 16);
- Rock flume (see Figure 17);
- Railroad flat cars; and
- Other methods as approved by ONEOK and appropriate agencies.

Soil will not be used to construct temporary equipment bridges.

2.7.2 Bridge Design and Maintenance

Bridges will be built and maintained in accordance with applicable permits. At a minimum, equipment bridges will be designed and installed to withstand the maximum foreseeable stream flow that may occur while the bridge is in place. Bridges at ESAs must be above the ordinary high water mark. Bridges will not restrict flow or cause water to pool and will be constructed with clean materials. Bridges will be designed and maintained to prevent soil from entering the waterbody. Erosion and sediment control barriers will be installed and maintained around vehicle access points as necessary to prevent sediment from reaching the waterway. Soil that accumulates on the bridge decking will be removed as needed, or as deemed necessary by ONEOK.

2.8 STREAM AND RIVER CROSSING CONSTRUCTION METHODS

The following stream and river crossing methods are typically used and are subject to further restrictions by ONEOK and applicable permits and subject to modifications as approved by appropriate regulatory agencies during construction.

2.8.1 Wet Trench Method

Installation

The wet trench method (see Figure 12) will be used to cross streams and rivers that are not required by permit to be crossed using a dry crossing technique (i.e., flume, dam and pump, or directional drill (see Figure 15). The wet trench method is not permitted at ESA locations. The following procedures will be used during wet trench crossings:

- Sediment control measures will be in place before grading from the 20-foot vegetative buffer left on each stream bank. Spoil containment structures will be installed back from the stream bank so that spoil does not migrate into the stream. Grading will be directed away from the waterbody to minimize the potential for sediment to enter the stream. The grading of stream banks will be restricted to the trench line and areas necessary for safe bridge installation.
- After grading, backhoes, or draglines will be used to excavate the trench. Excavating equipment will operate from one or both banks, without entering the stream. If equipment must encroach into the stream, it will operate on clean construction mats. Streambed material will be segregated and placed within a spoil containment structure in approved construction work area limits.
- In-stream trenching and backfilling on flowing waterbodies will typically be completed within 24 hours or less on minor waterbodies (<10 feet wide) and 48 hours or less on intermediate (>10 feet to 100 feet wide) and 72 hours at major (>100 feet wide) waterbodies, or as directed by applicable permits.
- Earthen trench plugs (hard plugs) between the stream and the upland or wetland trench will be left undisturbed during excavation of the in-stream trench to prevent diversion of the stream flow into the open trench and to prevent water that may have accumulated in the adjacent upland trench from entering the waterbody. Trench plugs will be removed immediately prior to pipe placement, and then replaced when the pipe is in place. Trench water accumulated upslope of trench plugs must be dewatered appropriately prior to trench plug removal.

- If trench dewatering is necessary, the pump intake will be suspended off the trench bottom and dewatering will take place into a sediment filter bag and/or a straw bale and geotextile dewatering structure (see Figures 20, 21A, 21B, and 21C) where directed by ONEOK. The trench will be dewatered in such a manner that no heavily silt-laden water flows into streams or wetlands, typically in a well-vegetated upland area (see Section 5.0). Only non-woven fabric will be used for filter bags. Landowner approval is required in advance of placement of dewatering structures outside of the approved construction workspace.
- Backfilling will begin after the pipe is positioned in the trench at the desired depth. Backfill material will consist of the spoil material excavated from the trench and parent streambed unless otherwise specified in state or federal permits. The in-stream trench will be backfilled so that the stream bottom is as near as practicable to its pre-construction condition, with no impediments to normal water flow.

Temporary Stabilization

ONEOK will restore the stream banks as near as practicable to pre-construction conditions unless that slope is determined to be unstable (see Section 2.9). Once the banks have been reshaped, ECDs will be installed within 24 hours of backfilling the crossing. Temporary slope breakers will be installed on all sloped approaches to streams in accordance with the spacing requirements outlined in Section 1.7.6.

A temporary seed mix, as indicated in the *Revegetation Plan*, and mulch and/or erosion control blankets will be installed within a 50-foot buffer on either side of the stream. A sediment barrier will be installed upslope of the temporary seeding area.

2.8.2 Dam and Pump Method

Installation

The dam and pump method is a dry-crossing method that is suitable for low flow streams and is a preferred alternative to fluming for crossing meandering channels. The dam and pump method involves damming of the stream with sandbags, inflatable dams, and/or steel plates upstream and downstream of the proposed trench before excavation (see Figure 15) and pumping water around the construction area. The dam and pump method is not permitted at ESA locations. The following procedures will be implemented for dam and pump crossings:

- Pumping of the stream flow across the ROW will commence simultaneously with dam construction to prevent interruption of downstream flow. Stream flow will be pumped across the construction area through a hose(s) and will be discharged to an energy-dissipation device, such as plywood boards, to prevent scouring of the streambed.
- The pumps will be located on the upstream side of the crossing and will be placed in impermeable, sided structures which will act as containment units for the pumps and fuel containers. The pumps used for the dam and pump crossing method will not be placed directly in the stream or on the streambed. Pumps will have a pumping capacity greater than the anticipated stream flow. The pumping operation will be monitored and adjusted as necessary to maintain an even flow of water across the work area and near-normal water levels upstream and downstream from the crossing. Backup pumps of equal or greater capacity will be on-site at all times in the event that the primary pumps fail.

- The pump intake must be suspended to prevent the uptake of sediment from the stream bottom and must be equipped with a screen with less than one-inch-diameter openings, or equivalent device, to prevent fish uptake.
- Spill kits, as described in the SPCC Plan, will be stored adjacent to pumps and fuel.
- Dams will be constructed of sandbags, inflatable dams, aqua-dams, and/or steel plates. The dams will prevent the stream from flowing into the construction area. The dams will be continuously monitored for a proper seal. Additional sandbags, plastic sheeting, steel plating, or similar materials will be used where necessary to minimize the amount of water seeping around the dams and into the construction work area.
- Backhoes located on one or both stream banks will excavate a trench across the streambed. Existing streambed materials will be segregated and placed within a spoil containment structure in approved construction work area limits.
- Earthen trench plugs between the stream and the upland trench will be used during excavation of the in-stream trench to prevent the diversion of any groundwater that seeps into the open trench. Trench plugs will be removed immediately before pipe placement and then replaced when the pipe is in place.
- Standing water that is isolated in the construction area by the dams will be pumped into a sediment filter bag and/or a straw bale and geotextile dewatering structure, generally located in a well-vegetated upland area, and discharged in such a manner that no heavily silt-laden water flows into streams or wetlands (see Section 5.0). Only non-woven fabric will be used for filter bags.
- Backfilling will begin after the pipe is positioned in the trench to the desired depth. Backfill material will consist of the spoil material and parent streambed excavated from the trench unless otherwise specified in state or federal permits. The in-stream trench will be backfilled so that the stream bottom is contoured to its pre-construction condition, with no impediments to normal water flow.

Bank Stabilization

For dry-ditch crossings, complete streambed and bank stabilization before returning flow to the waterbody channel. Once the stream banks have been stabilized, the dams and pump will be removed in a manner to minimize streambed disturbance. Restoration of the banks will be completed as described in Section 2.9.

2.8.3 Flume Method

Installation

The flume method is a dry-crossing method that is suitable for crossing sensitive, relatively narrow streams that have straight channels and are relatively free of large rocks and bedrock at the point of crossing. This method involves placement of flume pipe(s) in the streambed to convey stream flow across the construction area without introducing sediment to the water (see Figure 14). The dam and flume method is not permitted at ESA locations. The procedures for using the flume method are described below.

- The flume(s) will be of sufficient diameter to transport the maximum flows anticipated to be generated from the watershed. The flume(s) typically 40 to 60 feet in length, will be installed before trenching and will be aligned so as not to impound water upstream of the flume(s) or cause downstream bank erosion. The flumes will not be removed until after the pipeline has been installed, the trench has been backfilled, and the stream banks have been stabilized.
- The upstream and downstream ends of the flume(s) will be incorporated into dams made of sand bags and plastic sheeting (or equivalent). The upstream dam will be constructed first and will funnel stream flow into the flume(s). The downstream dam will prevent backwash of water into the trench and construction work area. The dams will be continuously monitored for a proper seal. Adjustments to the dams will be made where necessary to prevent large volumes of water from seeping around the dams and into the trench and construction work area.
- After the streambed is dewatered, backhoes located on one or both stream banks will excavate a trench across the streambed. Spoil generated during trenching will be stored in a straw bale/silt fence containment area located away from the stream banks within approved construction work areas.
- Earthen trench plugs between the stream and the upland trench will be used, during excavation of the in-stream trench to prevent diversion of the stream flow into the open trench or upland sediment flowing into the stream via the trench. Trench plugs will be removed immediately before pipe placement, and then replaced when the pipe is in place.
- If trench dewatering is necessary to complete the installation of the pipe, the discharge will be pumped into a sediment filter bag or a straw bale geotextile dewatering structure, into a well-vegetated upland area, and discharged in such a manner that no heavily silt-laden water flows into streams or wetlands (see Section 5.0). Non-woven fabric must be used for filter bags.
- Backfilling will begin after the pipe is positioned in the trench to the desired depth. Backfill material will consist of the spoil material excavated from the trench and parent streambed unless otherwise specified in state or federal permits. The in-stream trench will be backfilled so that the stream bottom is similar to its pre-construction condition, with no impediments to normal water flow in a manner to minimize streambed disturbance.

Bank Stabilization

For dry-ditch crossings, complete streambed and bank stabilization before returning flow to the waterbody channel. After the stream banks have been stabilized, the dams and flume will be removed from the streambed allowing water to resume its flow in the channel. Restoration of the banks will be completed as described in Section 2.9.

2.8.4 Horizontal Directional Drill (HDD) Method

Installation

Installing the pipe underneath a stream will involve placing a drill unit on one side of the stream (see Figure 15). Minor hand clearing is typically required, unless otherwise specified by a Project Permit, between the entry and exit points to facilitate the installation of the tracking wires, when wires are

needed, and for visual inspection of the drill path. A small diameter pilot hole will be drilled under the stream along a prescribed profile. After the pilot hole has been completed, barrel reams will be used to enlarge the pilot hole to accommodate the desired pipeline diameter. Drilling mud will be necessary to remove cuttings and maintain the integrity of the hole. Water from a ONEOK-approved source will be used to prepare the slurry of drilling mud and will be appropriated according to applicable permits (see Section 7.0). The pipe section will be pulled through the hole by the drilling rig and then welded to the adjoining sections of pipe on each side of the river.

The HDD or conventional bore method will be used at all ESA locations.

Drilling Mud

During drilling operations, drilling mud and slurry will be stored back from the river bank in an earthen berm sediment control structure, in tanks, or by other methods so that it does not flow into the stream, adjacent wetlands, or off the approved construction workspace.

ONEOK has developed a contingency plan to address measures to be performed in the event of a release of drilling mud onto the ground surface or waterbody. The plan stipulates monitoring for an inadvertent release of drilling mud during the HDD operation. The plan also outlines procedures for an inadvertent release in an ESA. See the ONEOK *Horizontal Directional Drilling Inadvertent Release Control Plan* for additional details.

After the pipe is in place, excess drilling mud and slurry will be disposed of properly, in accordance with applicable local, state, or federal regulations.

Bank Stabilization

The directional drilling method normally does not result in the disturbance of the stream banks or riparian vegetation, which reduces the potential for erosion and sedimentation at the stream crossing. Consequently, the ECDs that are installed at open-cut crossings typically are not necessary for drilled/bored crossings. However, ECDs may be utilized to assist in containing drilling mud, or adjacent disturbed ROW, on the approved construction workspace.

2.9 PERMANENT RESTORATION

Stream Banks

Stream banks disturbed during installation of the pipelines will be stabilized with erosion control materials such as jute or equivalent and seeded in accordance with ONEOK's *Revegetation Plan*. Permanent stabilization must occur prior to returning stream flow for dam and pump/flume crossings unless site and permit conditions delay permanent installation. Bank stabilization activity should not be more than 500 feet in length along the bank, and no material placed in excess of the minimum needed for erosion protection. The stabilization activity should not exceed an average of one cubic yard per running foot below the OHWM. All activity should be properly maintained, including repairing after storms or erosion events.

Where the banks have been disturbed, ONEOK will restore the slopes as near as practicable to pre-construction conditions unless that slope is determined to be unstable. Where the slope of a bank is determined to be unstable or has the potential to erode or fail, the bank will be reshaped to transition the disturbed areas into the natural stream bank with the intent to stabilize the bank and create a blended, natural appearance. If the original stream bank is excessively steep and unstable and/or flow conditions are severe, a more stable final contour may be specified, and alternate stabilization

measures may be installed. Alternate stabilization measures must conform to existing permit conditions. The contractor and Environmental Inspection team will inform ONEOK when restoring preconstruction contours is not feasible.

Berms or other sediment filter devices will be installed at the base of sloped approaches to streams greater than 5 percent and the outlet of the berm will be directed away from the stream into a well-vegetated area (see Figures 9, and 12). Temporary ECDs will remain in place until the area has been stabilized and adequate revegetation has been established.

2.9.1 Vegetative Bank Restoration

Typically, waterbody banks will be restored as near as practicable to preconstruction conditions after backfilling is complete and will be seeded with an appropriate seed mix as specified in the *Revegetation Plan*. ECDs (e.g. erosion control blankets, silt fences, etc.) will be installed as necessary based on site-specific conditions. If installation of the pipeline creates unstable soil conditions due to either stream meanders or stream crossing angle, ONEOK will consult with the appropriate agencies to identify additional site stabilization techniques.

2.9.2 Rock Riprap Restoration

Unstable soils and/or site-specific factors such as stream velocity and flow direction may require additional restoration efforts, such as installation of rock rip-rap, to stabilize disturbed stream banks. Rock rip-rap will be used only where site-specific conditions require and where applicable state permits or approvals have been acquired. Geotextile fabric and rock riprap will be placed according to site and permit conditions (see Figure 22). Disturbed soils upslope and on either side of the riprap will be prepared for seeding according to the *Revegetation Plan* and other stream bank protection requirements.

Rock riprap will not be installed below the OHWM, which will be marked upon request, or within wetlands. Rock riprap is not to be used as a support for a bridge within a wetland or a waterbody.

2.9.3 Bridge Removal

Equipment bridges will be removed during final cleanup or, if access is needed, after final cleanup and permanent seeding. Restoration of the bridge area will be completed upon bridge removal. Bridges installed for winter construction (if applicable) will be removed before spring break up unless access is needed for final cleanup and restoration other portions of the ROW.

2.9.4 Swales

Swales will be restored as near as practicable to original conditions. Swales will be seeded and either mulched with straw or erosion control blankets will be installed to the perceivable top of bank for the width of the approved construction workspace.

2.9.5 Drainage Ditches and Intermittent Streams

Drainage ditches and intermittent streams will be permanently restored and stabilized with erosion control blanket, permanent seeding, or other appropriate measures.

3.0 WETLAND CROSSING GENERAL REQUIREMENTS

Typical pipeline construction in wetlands will consist of clearing, stringing, trenching, dewatering, installation, backfilling, final grading, cleanup, and revegetation. However, due to the unstable nature of some wetland soils, construction activities may differ somewhat from those described for upland

areas. Construction activities will be minimized in wetlands to the extent practicable. ONEOK will also use special construction techniques to minimize the disturbance to plants and soils and to protect wetland hydrology.

Pre-construction planning is an essential part of wetland crossings. Wetland crossing requirements, including construction methods, timing, erosion control, and restoration, are described in this section and in the wetland crossing permits issued by state and federal agencies. Prior to construction, the Contractor may identify alternative provisions that would provide an equal or greater level of protection to wetland ecosystems if the Contractor considers certain parts of these procedures to be technically impractical due to site-specific engineering constraints. Any proposed alternative provisions must be submitted to ONEOK far enough in advance of construction to allow ONEOK an opportunity to review the alternatives and consult with the appropriate regulatory agencies without causing construction delays. The Contractor must receive written approval from ONEOK prior to implementing the alternative construction techniques.

The procedures in this section apply to all wetlands that will be affected by the project. These procedures require that judgment be applied in the field and will be implemented under the supervision of ONEOK. The intent of these procedures is to minimize construction-related disturbance and sedimentation of wetlands and to restore wetlands to pre-construction conditions to the extent possible. In the event a waterbody crossing is located within or adjacent to a wetland crossing, the measures in both Sections 2 and 3 will be implemented to the extent practicable.

3.1 WETLAND ACCESS

The Contractor must use the construction ROW, existing public roads, approved access roads, such as private roads under landowner agreement, to access wetland areas.

3.2 SPILL PREVENTION

3.2.1 Storage of Fuels and Other Materials

No storage of hazardous materials, chemicals, fuels, and lubricating oils, and no concrete coating activities will be permitted in, or within 100 feet of, any wetland boundary unless special provisions have been implemented in accordance with ONEOK's *SPCC Plan*.

3.2.2 Refueling, Fuel Handling, and Equipment Maintenance

Construction equipment will be refueled in upland areas at least 100 feet from a wetland. Where the Contractor and ONEOK determine that conditions require construction equipment (e.g., swamp hoe, trench dewatering pumps, or portable generators) to be refueled within 100 feet of a wetland, the Contractor must follow the procedures described in ONEOK's *SPCC Plan* and implement additional provisions based on site-specific conditions. No equipment will be washed within 100 feet of streams or waterbodies. Vehicles and equipment left on the ROW overnight must be parked at least 100 feet from a delineated wetland boundary unless special provisions have been implemented in accordance with ONEOK's *SPCC Plan*, secondary containment structures are functional and properly placed, and prior approval is obtained from ONEOK.

3.3 CLEARING

Clearing the construction ROW in wetlands will be similar to clearing in uplands. For construction to proceed, obstructions (e.g., trees, brush, and logs) need to be removed. Typically, low ground

pressure equipment will be used, limiting disturbance to the wetland. When clearing in wetlands, the following restrictions apply:

- The construction ROW width in wetlands will typically be limited to 75 feet as depicted in Figure 23 unless non-cohesive soil conditions require utilization of a greater width.
- Vegetation and trees within wetlands will be cut off at ground level, leaving existing root systems intact. Trees within ESAs will not be removed.
- Cuttings and debris will be removed from the wetland and disposed of properly.
- Between extra work areas and the edge of the wetland, limit the clearing of vegetation to the construction right-of-way.
- Mechanized tree clearing will not be allowed in forested wetlands or ESAs as identified by ONEOK.

3.4 EXTRA WORKSPACE IN WETLANDS

ONEOK attempted to locate extra workspace outside of wetlands wherever practicable; however, extra workspaces have been sited in select wetlands where the wetland is adjacent to a waterbody, road, railroads, foreign utility crossings, and/or pipeline cross-over. Clearing of forested wetlands for extra workspace will be avoided as much as possible and never allowed at ESA locations. Woody vegetation in wetlands will not be cleared for the purpose of extra workspace unless approved by the appropriate regulatory agency.

Staging areas, additional spoil storage areas, and other additional work areas (extra workspace) will be located in upland areas at least 50 feet away from wetland boundaries (see figure 23), where safe work practices or site conditions permit. These extra workspaces may be located closer if the area is disturbed agricultural land, such as a row crop. If site conditions do not permit a 50-foot setback, then these areas will be located as far away from the wetland as is practicable. Vegetation will not be cleared between these areas and the wetland in any event. No construction activities including vegetation clearing or earthwork will occur between the extra workspace and sensitive resource areas (wetlands or waterways). The size of the additional workspace areas will be limited to the minimum needed to construct the wetland crossing.

3.5 GRADING IN A WETLAND

Grading in a wetland, if required, will be conducted in a manner consistent with applicable federal, state, and local permits. Grading activities will be confined to directly over the trench line. Grading outside the trench will only be allowed where required to ensure safety and restore the ROW after backfilling the trench. No grading is permitted within ESAs.

3.6 CONSTRUCTION MATTING

Supplemental equipment supports, such as timber mats (see Figure 23), will be used where necessary to provide temporary portable support for construction equipment and minimize soil compaction and/or soil mixing. No equipment supports are permitted within ESAs. To prevent the spread of noxious and invasive plant species, timber mats must be free of soil and plant material prior to being transported onto the ROW. The Contractor is responsible for having a sufficient number of construction mats to perform the work. Tree stumps, brush riprap, imported soil, and rock fill will not be brought in to stabilize the ROW, or excavations in wetlands. Timber riprap (also known as corduroy

road) cannot be used without prior written approval from ONEOK. Pre-existing corduroy roads in wetlands may be used but may not be improved, maintained, restored, or replaced without site-specific authorization from applicable agencies. Subsoil excavated from the pipeline trench in the wetland may be placed on top of equipment mats for additional stabilization.

All timber mats, construction debris, and larger woody vegetative debris will be removed during the cleanup of wetlands to pre-construction condition or equivalent to surrounding area.

3.7 TRENCHING

Excavation of the pipeline trench in wetlands typically will be accomplished using backhoe excavators. The duration of open trench will be minimized to the extent possible.

3.8 TOPSOIL SEGREGATION

Typically, when constructing in wetland areas without standing water, up to one foot of topsoil (organic layer) will be stripped from the trench line and stockpiled separate from trench spoil. In standing water wetlands, topsoil segregation is not typically practical; however, ONEOK will attempt to segregate as much of the organic layer as possible based on site/saturation conditions. If normally unsaturated wetlands are saturated at the time of construction, topsoil segregation will be attempted according to Figure 23 and based on recommendations from ONEOK and appropriate regulatory agencies. Topsoil will be restored to its approximate original stratum, after backfilling is complete.

3.9 TRENCH BREAKERS

Trench breakers will be installed as necessary, near the wetland boundary, to maintain the original wetland hydrology.

3.10 PIPELINE INSTALLATION

The following procedures are intended to minimize siltation and disturbance to wetlands during installation.

3.10.1 Push/Pull Method

Large wetlands with standing water can generally not be crossed with typical crossing methods. In these areas, the pipeline will be assembled in an upland area and positioned in the trench

using the "push-pull" and/or "float" techniques. Typically, this fabrication requires use of extra workspace adjacent to the construction ROW. The trench will be dug by a backhoe (or equivalent) supported on timber mats. The prefabricated section of pipeline will then be pushed-pulled into position or floated across the wetland. When the pipeline is in position, the floats, if used, will be removed and the pipeline will sink into position. Barrels, floats, and banding will be recovered and removed prior to backfilling. The trench will then be backfilled, and the wetland will be restored by a backhoe or similar equipment working from construction mats or by low ground pressure equipment. The Push/Pull method is not permitted in ESAs.

3.11 TEMPORARY EROSION AND SEDIMENT CONTROLS

ECDs at approaches to wetlands will be installed as described in this section and Section 1.7.5, according to the specifications presented on Figures 3 and 4. ECDs (e.g., silt fence) will be installed across the entire construction ROW upslope of the wetland boundary, where necessary, to prevent sediment flow into the wetland. Where wetlands are adjacent to the construction ROW and the ROW slopes toward the wetlands, ECDs will be installed along the edge of the construction ROW as

necessary to prevent sediment flow into the wetlands. ECDs will be installed along the edge of the construction ROW, as necessary, to contain spoil and sediment within the construction ROW through wetlands. In the travel lane, these may incorporate removable sediment barriers or drivable berms. Removable sediment barriers can be removed during the construction day and re-installed after construction has stopped for the day or when heavy precipitation is imminent.

ECDs will be maintained in proper working order to prevent the flow of sediment into wetlands from spoil piles or sloped approaches that are adjacent to the wetlands. When the depth of sediment reaches one-half of the height of a sediment barrier, the barrier will be replaced, and/or the sediment removed. Non-functional sediment-control measures will be repaired, replaced, or supplemented.

3.12 BACKFILLING

The Contractor will restore wetlands as near as practicable to pre-construction conditions and must make a reasonable attempt to return the subsoil its pre-construction density. During the backfilling of wetland areas, subsoil material removed from the trench during construction will be replaced so that the material is not mounded above the adjacent ground surface (undisturbed trench wall). Subsoil that exceeds the elevation of the ground adjacent to the trench will be removed from the wetland and disposed of in an upland area or a ONEOK-approved disposal site. After the trench has been backfilled with subsoil, previously segregated topsoil will be spread over the trench area and mounded no more than 12 inches above the adjacent, undisturbed soil.

3.13 ROUGH GRADING, CLEANUP, AND TEMPORARY RESTORATION

Cleanup and rough grading activities may take place simultaneously. Cleanup activities typically will involve removing construction debris and replacing fences removed during construction. Rough grading will include restoring original conditions within the disturbed areas (i.e., ditch line, spoil storage areas, and equipment travel lane) and installing or repairing temporary ECDs. Temporary slope breakers will be installed near the boundary between the wetland and adjacent sloped approaches, to prevent sediment flow into the wetland.

3.13.1 Timing

Cleanup and rough grading (including installation of ECDs) will begin as soon as practical after the trench is backfilled, weather permitting.

3.13.2 Temporary Stabilization

Where necessary to prevent erosion and in accordance with *ONEOK's Revegetation Plan*, disturbed wetland areas will be stabilized by seeding with a temporary cover at a rate adequate for germination and ground cover unless standing water is present. For farmed wetlands, seeding requirements will be applied for agricultural lands or as required by the landowner.

The Contractor will not use fertilizer, lime, or mulch in wetlands unless required in writing by the appropriate land management agency. ONEOK does not propose permanent planting or seeding in wetlands.

4.0 HIGHWAY, ROAD, AND RAIL CROSSINGS

4.1 EXTRA WORKSPACE

Extra workspaces for bored road and railroad crossings and open-cut road crossings will be determined on a site-specific basis and must be approved by ONEOK prior to use. These workspaces will be adjacent to the road or railroad (see Figure 24).

4.2 MAINTENANCE

Roadway crossings will be maintained in a condition that will prevent the tracking of mud onto the roadway. If mud is tracked onto a roadway, the Contractor will remove accumulated material from the road and place within a sediment barrier as soon as practical.

4.3 TEMPORARY EROSION AND SEDIMENT CONTROLS

Temporary ECDs (e.g., silt fence and/or double-staked straw bales) will be installed on sloped approaches to road crossings where vegetation has been disturbed as discussed in Section 1.7.5 and installed according to the specifications presented on Figures 3 and 4.

5.0 CONSTRUCTION DEWATERING

5.1 TRENCH DEWATERING

The following additional guidance is provided regarding trench dewatering activities to employ the maximum amount of reasonable protective measures to sensitive resource areas.

At each location where dewatering is to be conducted, the contractor must consider the following conditions in planning the dewatering event. Prior to initiating dewatering activities, the contractor must check the water discharge situation to ensure that the BMPs are applied in such a way as to minimize the potential for water containing sediment from reaching a sensitive resource area. Landowner approval must be acquired in advance of placement of dewatering structures outside of the approved construction ROW, if required. If dewatering off the-ROWROW, a well-vegetated upland area will be selected.

- **Water Discharge Setting** – The contractor will assess each water discharge situation to include:
 - Soil Type - The soil types the discharged water would flow over. The management of discharged water traveling over sandy soil is more likely to soak into the ground as compared to clay soils.
 - Ground Surface - The topography and vegetation in the area that would influence the surface flow of the discharged water.
 - Adjustable Discharge rate - The flow rate of the discharged water (which may need to vary) should be managed based on the site conditions and applicable permits to minimize instances of water from reaching a sensitive resource area. (Example - water discharged at 500 gallons per minute may soak into the ground while if discharged at a higher flow rate would cause water to flow via overland runoff into a waterbody).
 - Discharge Outfall - The amount of hose needed to attempt to discharge water at a location which drains away from waterbodies or wetlands.

- **Pump Intake** - Install a float near the suction end of the intake hose to prevent the uptake of sediment from the trench bottom (see Figures 20, 21A, 21b, and 21C). Alternative methods may be used where the performance of the alternative method is equal to or greater than the use of a float.
- **Overwhelming Existing Drainage** - If clean discharged water will reach a waterbody, control the discharge rate to prevent downstream flooding and/or erosion.
- **Filtering Mechanism** – All dewatering discharges will be directed through a filtering device as indicated below.
 - Well-Vegetated Upland Area – Water can be directed to a well-vegetated upland area through a geotextile filter bag. The ground at the discharge location will be protected as necessary to prevent scouring/erosion of the ground surface at the end of the discharge hose. Geotextile bags will be sized appropriately for the discharge flow rate and suspended sediment particle size.
 - Straw Bale Dewatering Structure – Where the dewatering discharge point cannot be located in an upland area due to site conditions and/or distance, the discharge will be directed into a straw bale dewatering structure. The size of the straw bale dewatering structure is dependent on the maximum water discharge rate. A straw bale dewatering structure should be used in conjunction with a geotextile filter bag to provide additional filtration near sensitive resource areas.
 - Alternative dewatering methods (e.g., use of water cannons) may be approved by ONEOK on a site-specific basis.
- **Monitoring** – Trench dewatering activities will be monitored at all times by the contractor.

5.1.1 Regulatory Notification and Reporting

ONEOK will notify appropriate agencies as required by all permits/authorizations. Reports regarding the volume and quality of the water withdrawn and discharged will be submitted by ONEOK, if required by the applicable permits. The Contractor will assist ONEOK in collecting appropriate data and any water samples required or in determining volumes of water appropriated.

5.1.2 Flow Measurement

The volume of water discharged from the trench will be recorded if required by the applicable permits. The volume may be determined using a flow meter, or equivalent method as dictated by permit stipulations.

5.1.3 Water Sampling

Water discharged from trench dewatering locations may need to be sampled as required by NPDES discharge permits. If required, the Contractor will assist ONEOK in obtaining these samples and will be responsible for complying with the permit limitations.

6.0 HYDROSTATIC TESTING

Hydrostatic testing involves filling the new pipeline segments with water acquired in accordance with applicable permits, raising the internal pressure level, and holding that pressure for a specific period of time per federal Department of Transportation regulation (49 CFR 195) to verify that there are no

flaws in the pipe or welds. Pre-built sections (e.g., HDD sections) may be hydrostatically tested prior to installation. After the hydrostatic test is completed, the line will be depressurized, and the test water will be discharged. Contractor will refer to the NPDES permit issued for water discharge and plan accordingly to meet the conditions of the permit. Depending on the water source and applicable permits, the hydrostatic test water may be discharged to the ground, hauled off to a ONEOK-approved disposal location, or reused for dust control.

6.1 SITING OF TEST MANIFOLDS

Hydrostatic test manifolds will be installed where necessary to ensure proper test pressures. To prevent the spread of noxious and invasive species, hydrostatic test equipment must be dry and free of soil and plant material prior to being transported onto the ROW. The selected location of test manifolds is based on engineering requirements to meet proper test pressures and incorporates changes due to topography. Where feasible, ONEOK will incorporate minor adjustments to the test manifold locations to avoid placement in wetlands and riparian areas. However, completely avoiding the placement of a test manifold in a wetland may not always be possible. The Contractor will install appropriate erosion and spill control measures where ONEOK determines that topographic conditions, primarily elevation changes, require test sections to be located in a wetland or riparian area.

The operation and refueling of hydrostatic test equipment will be in accordance with the conditions outlined in ONEOK's *Spill Plan*.

7.0 WATER APPROPRIATION SOURCES AND DISCHARGE LOCATIONS

During construction, water required for hydrostatic testing of the mainline pipe and HDD pipe sections, directional drilling, and dust control operations may be obtained from local sources, such as lakes, streams, and private or municipal wells. Water will only be withdrawn from sources approved by ONEOK and in accordance with applicable permits, which will be specific for each state the Demicks Lake Pipeline crosses. Where water is appropriated from lakes or streams, the intake hose will be suspended off the stream or lake bottom and will be screened to prevent entrainment of fish. If appropriation is scheduled to occur during possible periods of low flow, including frozen conditions, a backup source will be identified. Water appropriation permits in Montana cannot account for backup water sources. Water used for dust control activities will be applied to roads, disturbed areas, and soil piles as described in ONEOK's *Dust Control Plan*.

7.1 APPROPRIATION FLOW MEASUREMENT

During withdrawal, adequate waterbody flow rates and volumes will be maintained to protect aquatic life and allow for downstream uses. At no time will the withdrawal rate for the water source exceed the rate specified in the applicable permits.

The volume and rate of withdrawal will be monitored to comply with applicable permit conditions. The withdrawal rate and total volume of water appropriated will be measured with a flow meter (or equivalent) and recorded. In Montana a project completion form is required after water use ends.

7.2 TEST WATER DISCHARGE

Hydrostatic test water discharges, sampling, testing and recordkeeping will be conducted in compliance with state-issued NPDES permits. Water used for hydrostatic testing of the mainline and HDD pipe sections will typically be discharged back to the waterbody from which it was appropriated (via direct discharge or through a dewatering structure built in an adjacent upland area) unless an

alternate discharge location has been approved by the applicable agencies. Hydrostatic test waters will not be transferred from one waterbody to another, across watershed, or major drainage divides unless specifically allowed by applicable permits. No additives to the water are permitted unless written approval is received from ONEOK and applicable permits authorize such additives.

Prior to hydrostatic testing the pipeline, ONEOK will prepare the pipe by removing accumulated construction debris, mill scale, dirt, and dust using a cleaning pig. The debris will be collected in a temporary receiver and will be properly disposed of by the Contractor. Upon completion of the cleaning operation, the pipeline will be sealed with the test headers.

Test headers and pigs will be arranged to allow for rinse water to be installed ahead of the fill pigs. Rinse water must be treated and disposed of in accordance with applicable permit conditions.

Following testing, the test section will be depressurized, and the water will be discharged to a well-vegetated, upland area and/or an appropriate dewatering structure, as described in the applicable permit. Dewatering structures include geotextile filter bags and/or a straw bale structure that may or may not be lined with geotextile fabric depending on the flow rate and overall volume of the discharge. Direct discharges to surface waters will be directed through an energy dissipation device such as a splash pup. Additional best management practices, such as the use of plastic sheeting or other material to prevent scour, will be used as necessary to prevent excessive sedimentation during dewatering. For example, in areas where highly erodible soils exist, the contractor may use layers of visqueen (or similarly effective fabric) anchored in place during the discharge.

To minimize the potential for introduction and/or spread of invasive species due to hydrostatic testing activities, ONEOK proposes to discharge water to the same source watershed from which it was appropriated, unless otherwise specified in a Project Permit. If water is used to test multiple test sections, it will be relayed back to the source water through the pipeline for final discharge. Test water will not be discharged to a waterbody other than the appropriation source or a location within the same watershed, unless coordinated and permitted through the applicable agencies.

7.2.1 Discharge Flow Measurement

The volume and rate of discharge will be monitored to comply with applicable permit conditions. The discharge rate and total volume of water discharged will be measured with a flow meter (or equivalent) and recorded. At no time will the discharge rate exceed the rate specified in the applicable permits. In the event no maximum discharge rate is identified, discharges will be monitored and adjusted as necessary to avoid overwhelming the discharge structure and scouring or sediment transport from the discharge location.

7.2.2 Discharge Water Sampling

Where required by permit conditions, ONEOK will sample the water during discharge. The Contractor will assist ONEOK in obtaining these samples. Chlorinated source water will be sampled at appropriation. If chlorine levels are at or above aquatic toxicity standards, the water will not be discharged directly to surface water.

7.3 REGULATORY NOTIFICATION AND REPORTING

ONEOK will notify appropriate agencies of the time of appropriations and/or discharges in accordance with applicable permit conditions. Reports regarding the volume and quality of the water withdrawn will be submitted by ONEOK if required by the applicable permits.

8.0 REVEGETATION

Permanent revegetation will involve preparing the seedbed and seeding disturbed, non-agricultural areas. The approved construction workspaces will be seeded as soon as possible after backfilling, weather and soil conditions permitting. With the exception of wetland areas, fertilizer and pH modifying agents (e.g., lime) will be applied as specified by ONEOK, in consultation with appropriate state and federal agencies and landowners. Refer to ONEOK's *Revegetation Plan* for specific information.

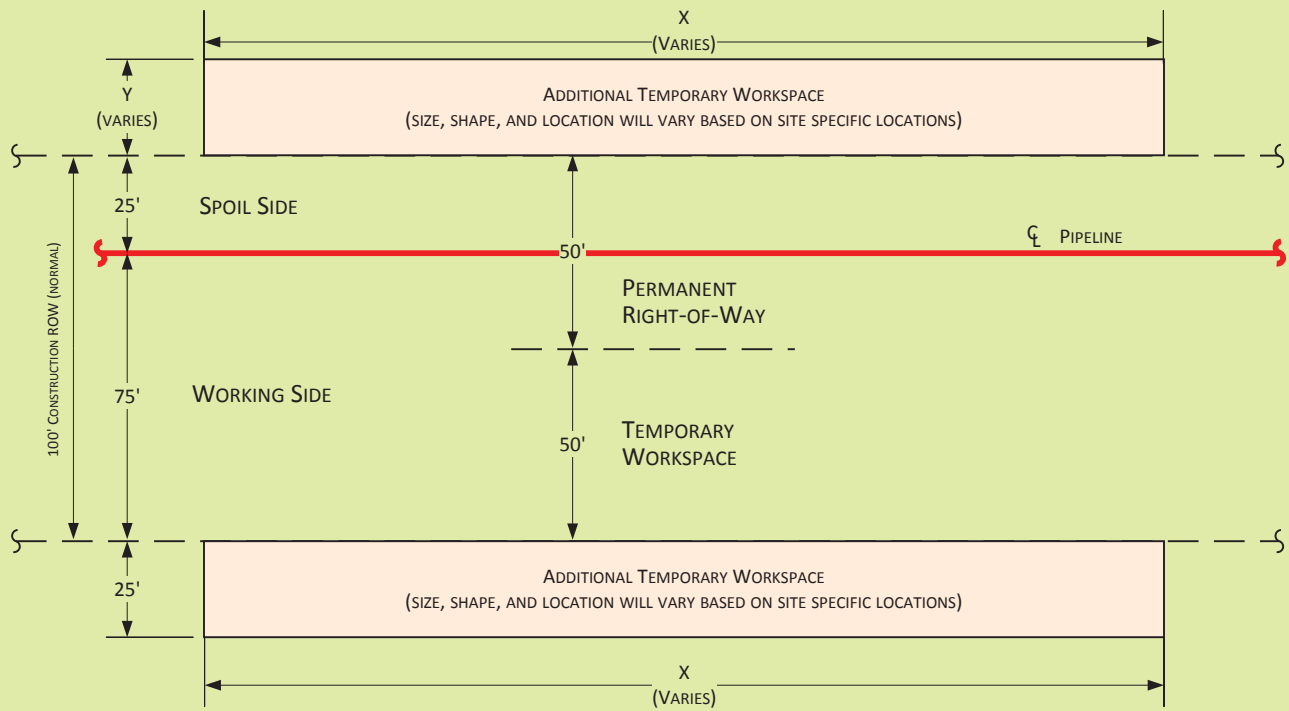
Revegetation will occur in accordance with stormwater permits and will be considered to have reached final stabilization when all soil disturbing activities are complete, and a uniform perennial vegetative cover with a density of 70 percent of the typical or existing background vegetative cover for the area has been established on disturbed unpaved areas and areas not covered by permanent structures.

DRAFT

This page intentionally left blank

Construction Mitigation and Restoration Plan
Figures

This page intentionally left blank

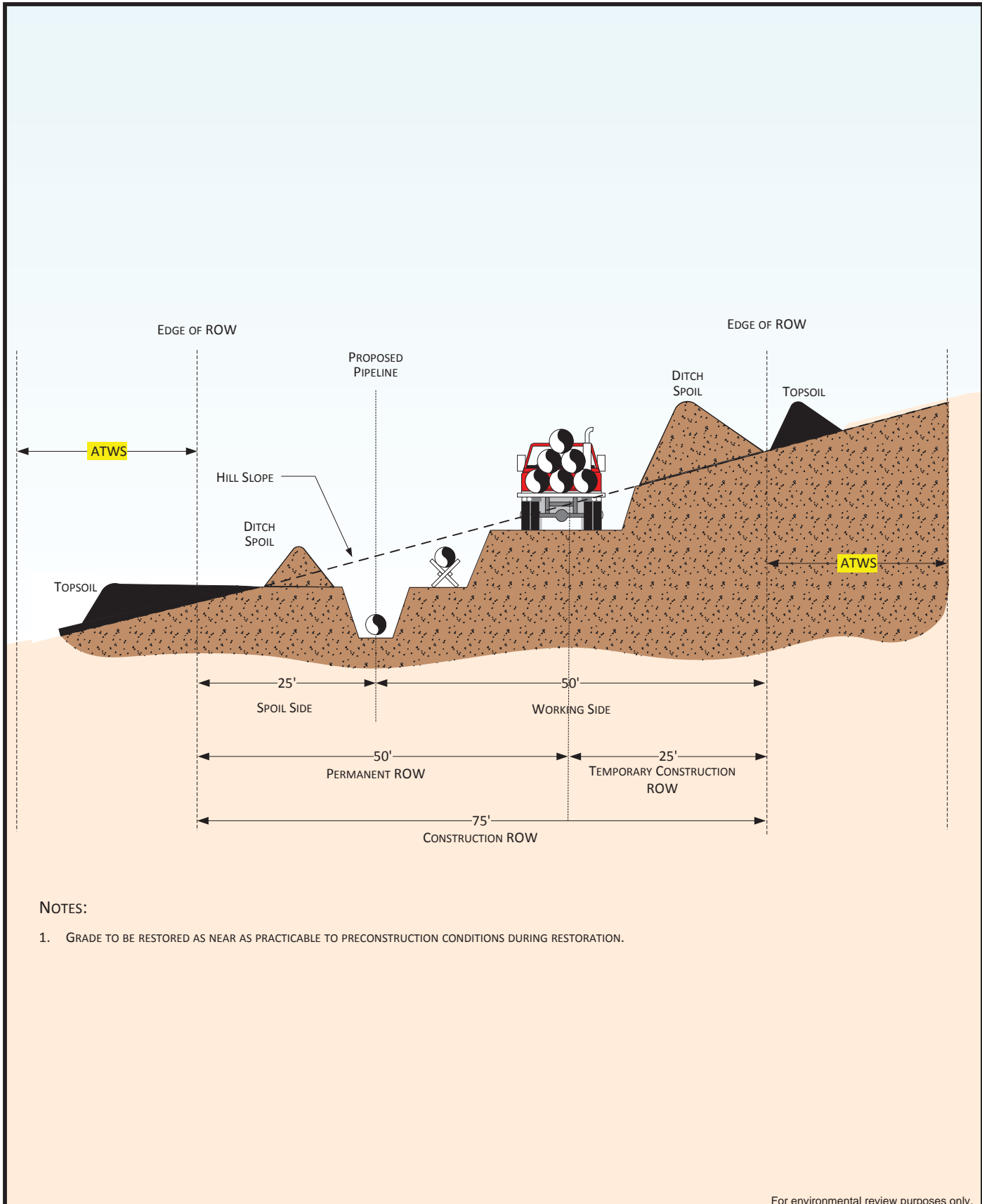


For environmental review purposes only.



Figure 1
Typical Construction Layout



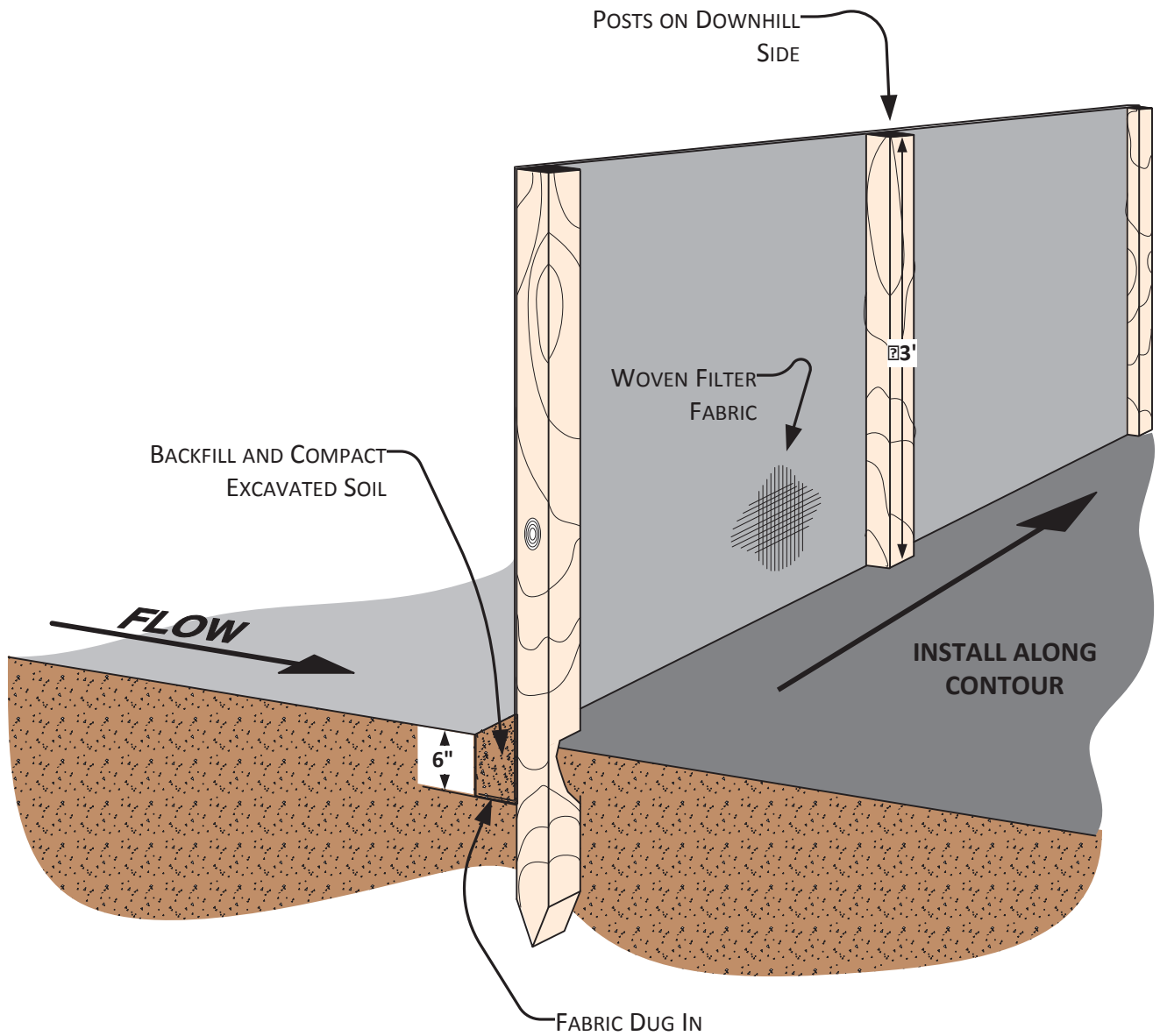


For environmental review purposes only.



Figure 2
Typical Construction ROW
on Sloping Terrain



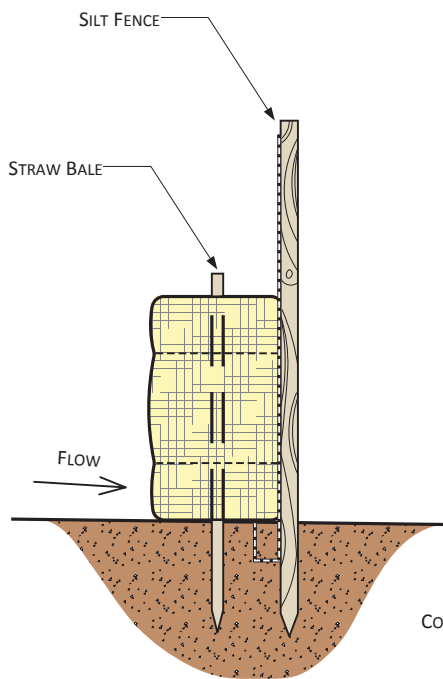
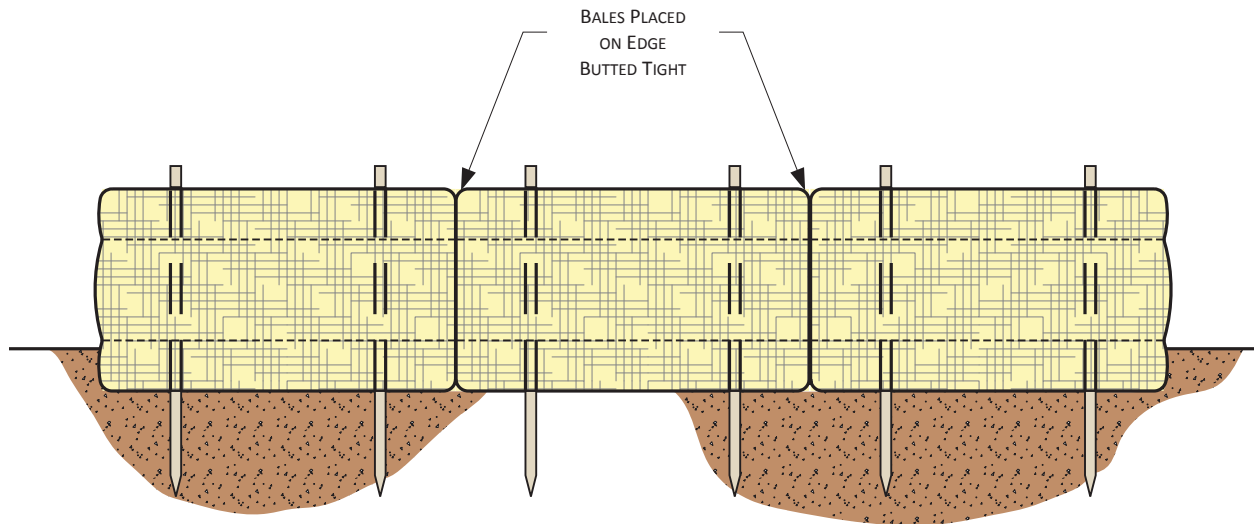


For environmental review purposes only.

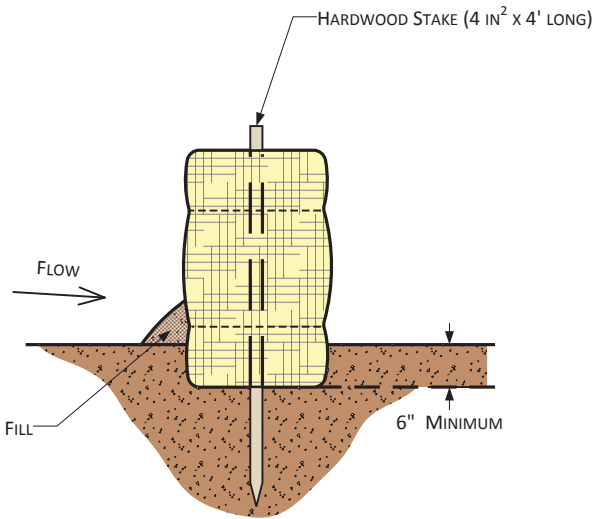


Figure 3
 Typical Silt Fence Installation
 (OKS-7901-ENV-01)





STRAW BALES & SILT FENCE



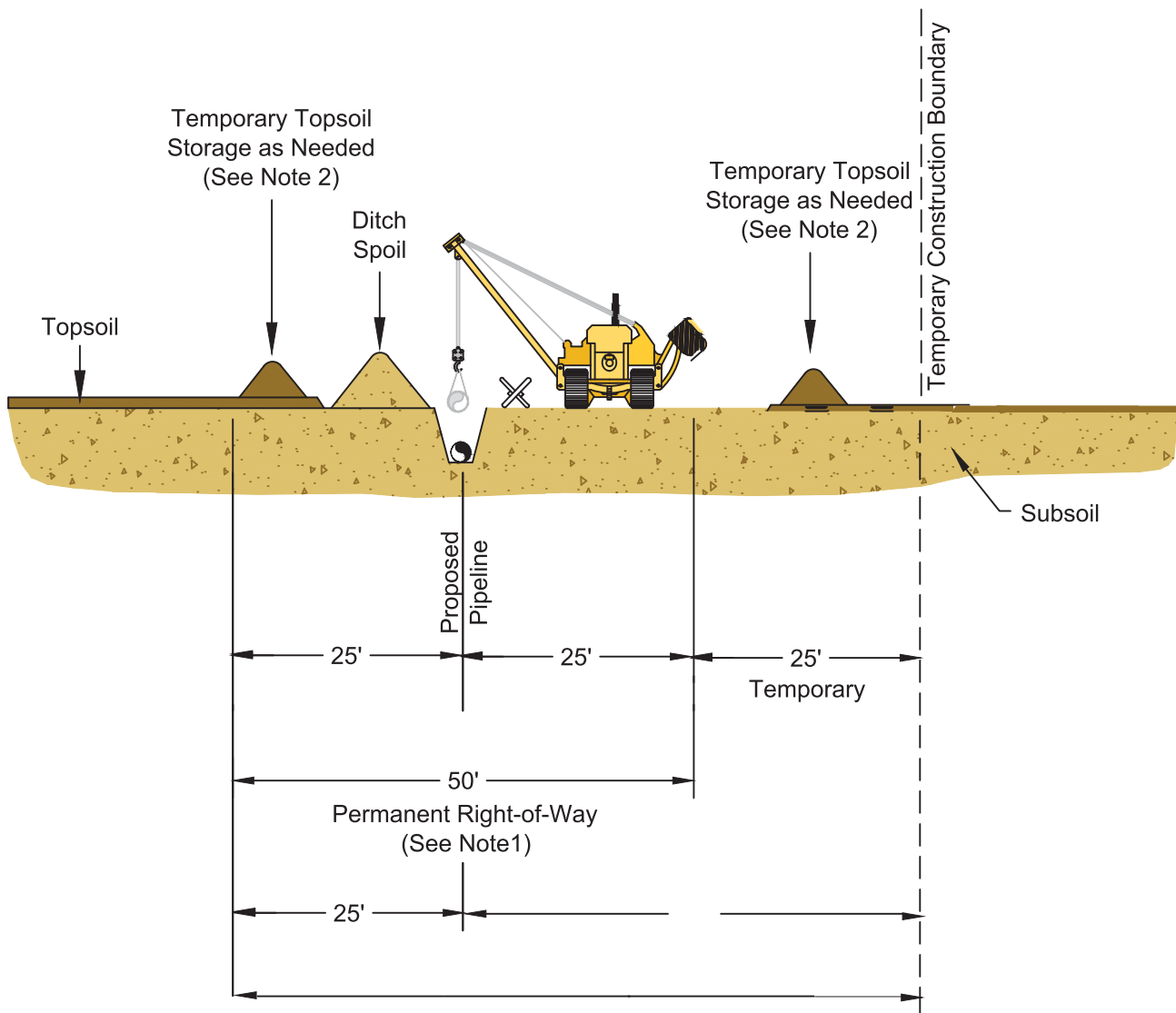
STRAW BALES ONLY

For environmental review purposes only.



Figure 4
 Typical Straw Bale Installation
 (OKS-7901-ENV-02)





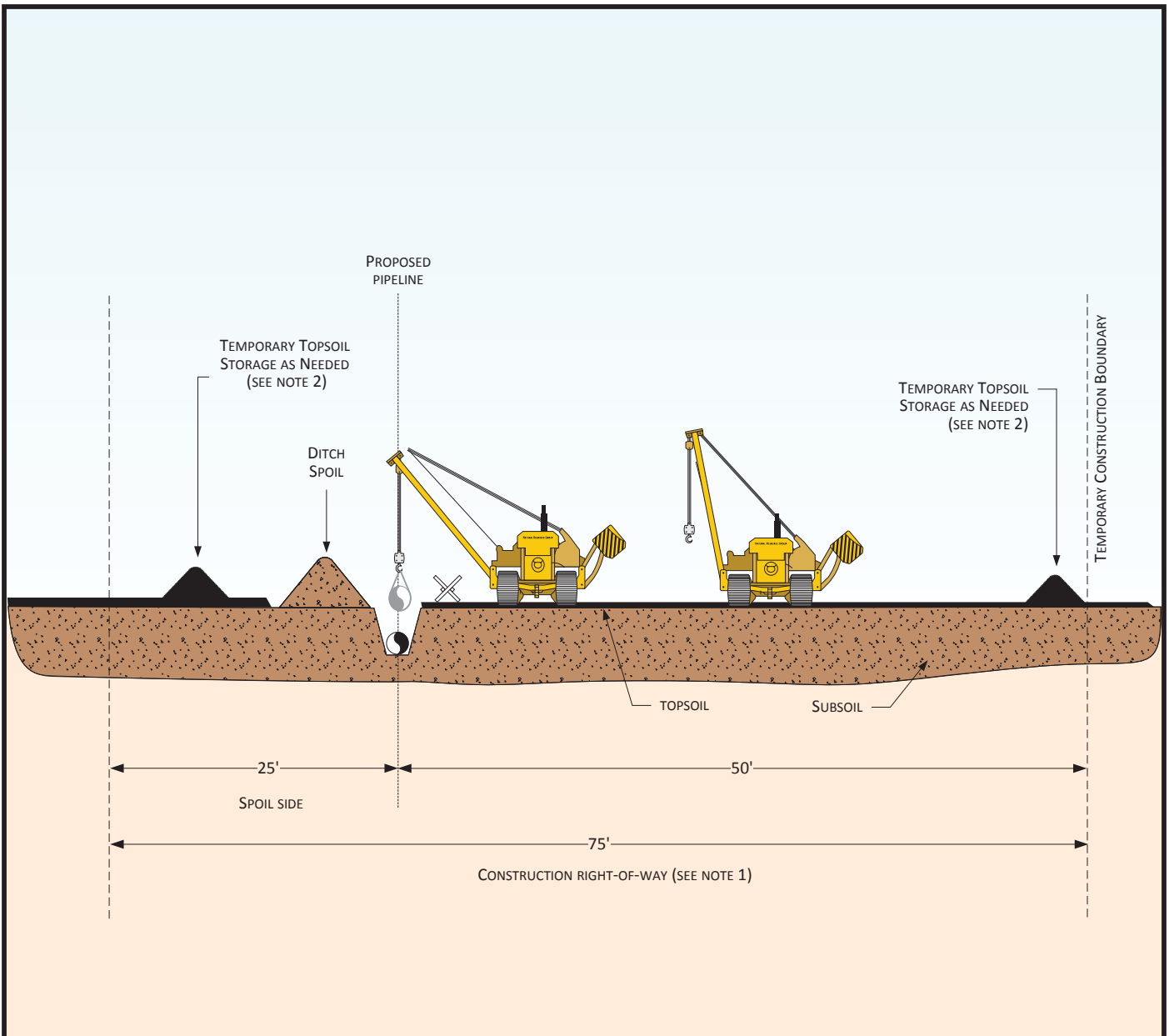
Notes:

1. Construction right-of-way will typically be 75 feet wide. The spoil side will be approximately 25 feet wide. The working side will be 50 feet wide.
2. This drawing reflects "Full Right of Way " topsoil stripping procedure. Stockpile topsoil separately from ditch spoil as shown or in other configurations approved by the company.



Figure 5
 Typical Topsoil Segregation Trench
 Right-of-Way
 (OKS-7901-CONST-01c)





PROFILE

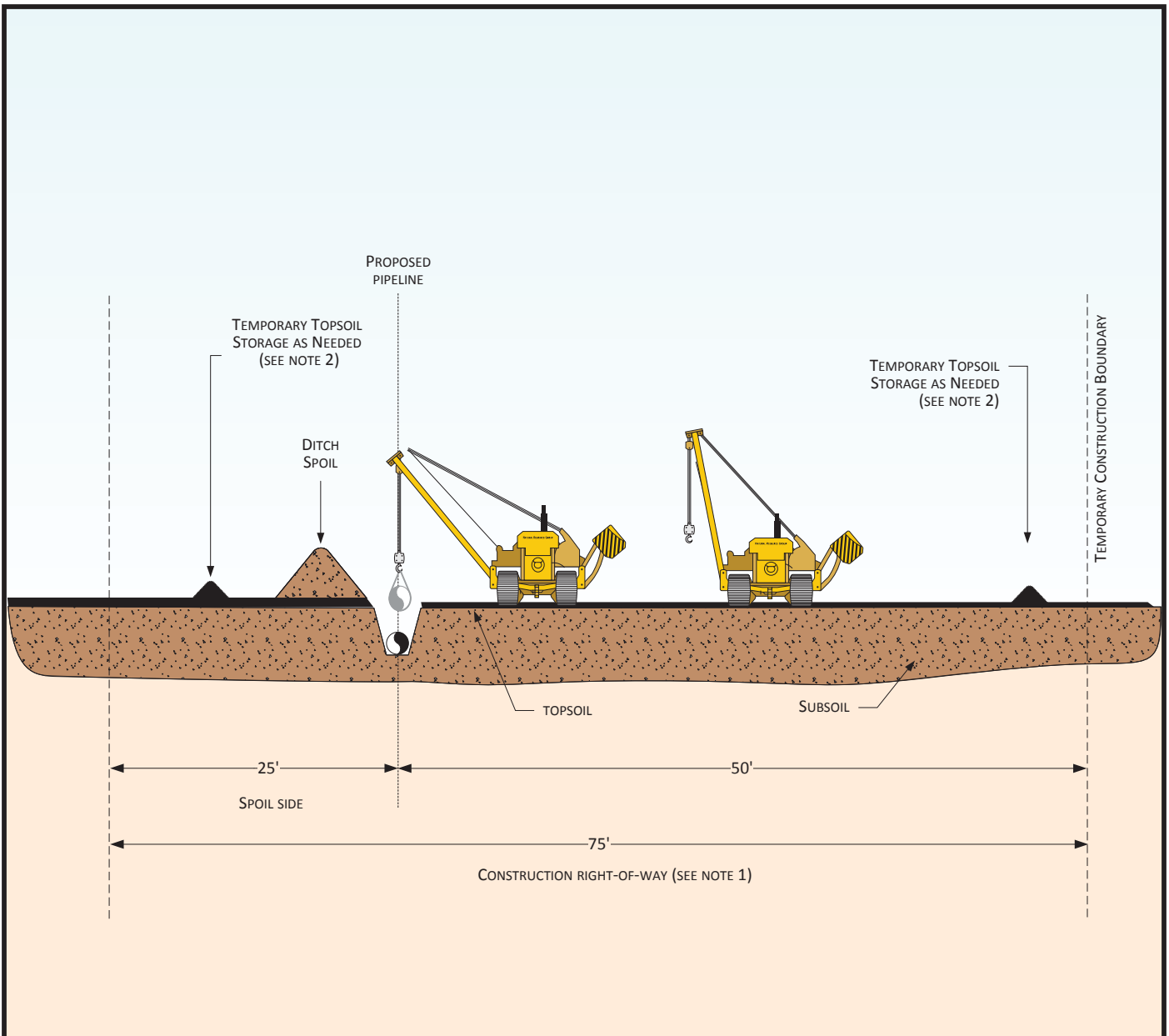
NOTES:

1. CONSTRUCTION RIGHT-OF-WAY WILL TYPICALLY BE 75' WIDE. THE SPOIL SIDE WILL BE APPROXIMATELY 25' WIDE. THE WORKING SIDE WILL BE 50' WIDE.
2. THIS DRAWING REFLECTS "DITCH PLUS SPOIL" TOPSOIL STRIPPING PROCEDURE. STOCKPILE TOPSOIL SEPARATELY FROM DITCH SPOIL AS SHOWN OR IN OTHER CONFIGURATIONS APPROVED BY THE COMPANY.

Figure 6

Typical Topsoil Segregation
Ditch Plus Spoil





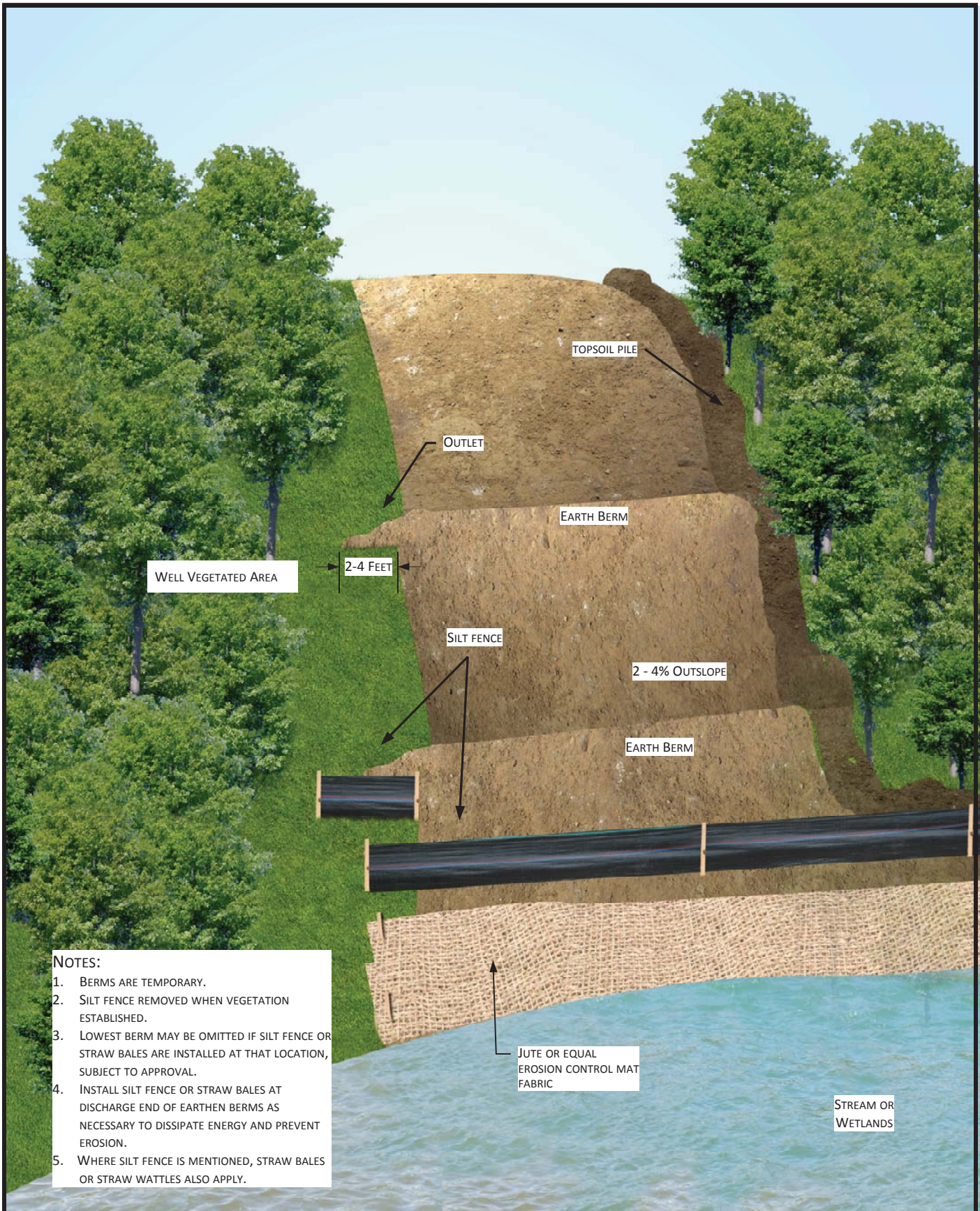
PROFILE

NOTES:

1. CONSTRUCTION RIGHT-OF-WAY WILL TYPICALLY BE 75' WIDE. THE SPOIL SIDE WILL BE APPROXIMATELY 25' WIDE. THE WORKING SIDE WILL BE 50' WIDE.
2. THIS DRAWING REFLECTS "TRENCH LINE ONLY" TOPSOIL STRIPPING PROCEDURE. STOCKPILE TOPSOIL SEPARATELY FROM DITCH SPOIL AS SHOWN OR IN OTHER CONFIGURATIONS APPROVED BY THE COMPANY.

Figure 7
 Typical Topsoil Segregation
 Trench Line Only



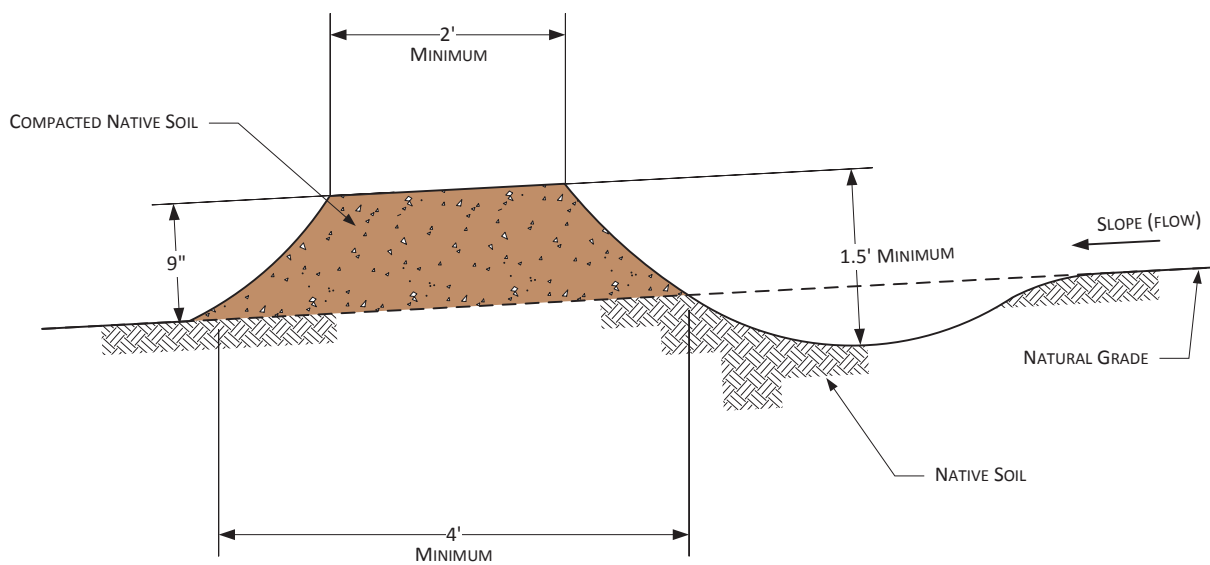


NOTES:

1. BERMS ARE TEMPORARY.
2. SILT FENCE REMOVED WHEN VEGETATION ESTABLISHED.
3. LOWEST BERM MAY BE OMITTED IF SILT FENCE OR STRAW BALES ARE INSTALLED AT THAT LOCATION, SUBJECT TO APPROVAL.
4. INSTALL SILT FENCE OR STRAW BALES AT DISCHARGE END OF EARTHEN BERMS AS NECESSARY TO DISSIPATE ENERGY AND PREVENT EROSION.
5. WHERE SILT FENCE IS MENTIONED, STRAW BALES OR STRAW WATTLES ALSO APPLY.

Figure 8
 Typical Temporary Berms
 Perspective View





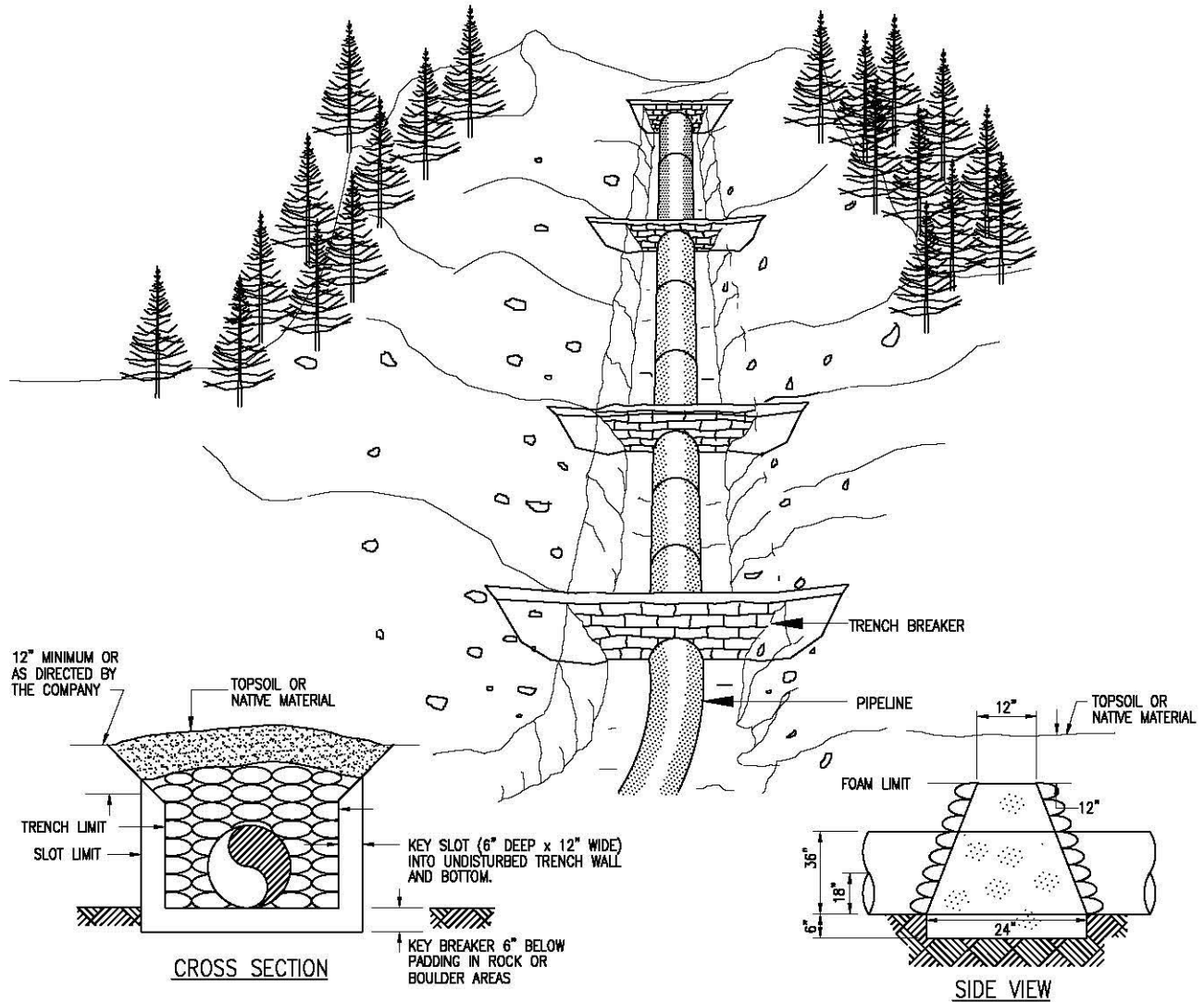
NOTES

1. BERMS SHALL BE CONSTRUCTED WITH 2 TO 4 PERCENT OUTSLOPE.
2. BERMS SHALL BE OUTLETED TO WELL VEGETATED STABLE AREAS,
SILT FENCES, STRAW BALES OR ROCK APRONS.
3. BERMS SHALL BE SPACED AS DESCRIBED IN CONSTRUCTION SPECIFICATIONS.
4. ADDITIONAL INFORMATION INCLUDED ON OTHER DRAWINGS.

For environmental review purposes only.

Figure 9
 Typical Temporary or Permanent Berms
 Elevation View





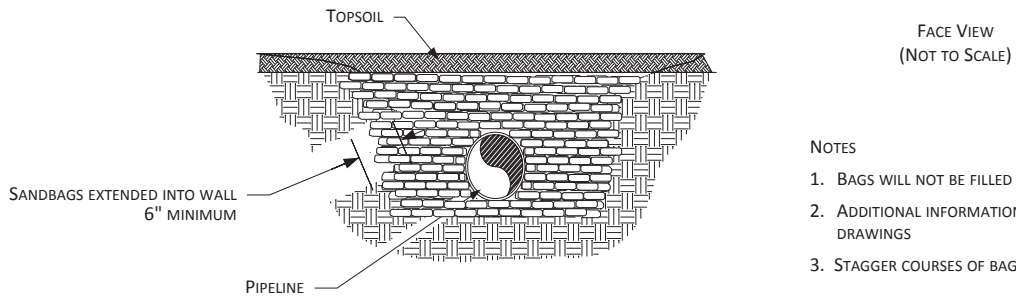
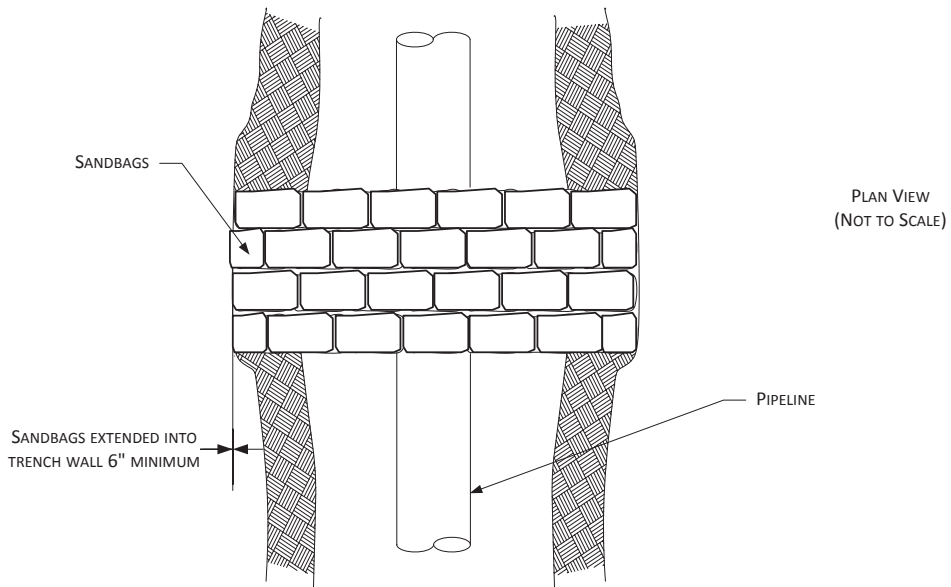
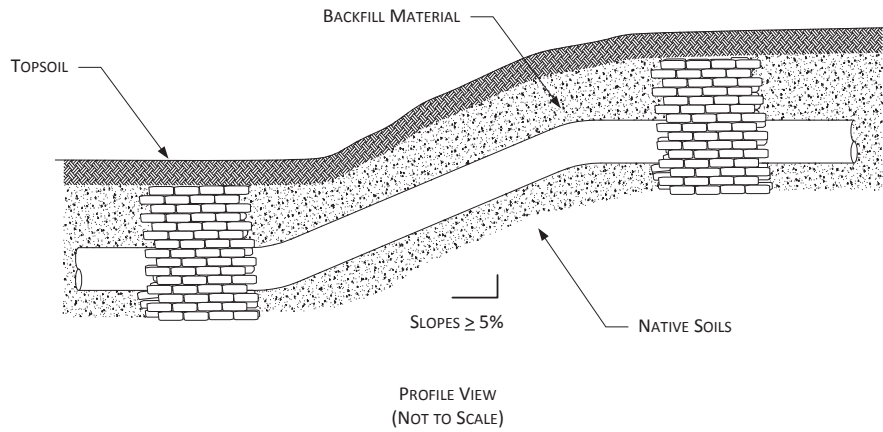
NOTES:

1. TRENCH BREAKERS SHALL BE INSTALLED:
 - ON SLOPES ALONG THE TRENCH LINE WHERE THE NATURAL DRAINAGE PATTERN, PROFILE, AND TYPE OF BACKFILL MATERIAL MAY RESULT IN LOSS OF BACKFILL MATERIAL OR ALTERATION OF THE NATURAL PATTERN;
 - AT THE BASE OF SLOPES ADJACENT TO WATERBODIES AND WETLANDS;
 - WHERE NEEDED TO AVOID DRAINING A WETLAND;
 - ON UPLAND SLOPES, AT THE SAME SPACING AS SLOPE BREAKERS AND UP SLOPE OF SLOPE BREAKERS;
 - IN CULTIVATED LAND AND RESIDENTIAL AREAS WHERE PERMANENT SLOPE BREAKERS ARE NOT TYP. INSTALLED, AT THE SAME SPACING AS IF PERMANENT SLOPE BREAKERS WERE REQUIRED.
2. EACH SAND BAG SHALL BE OF DIMENSION 14"x26" AND SHALL BE WOVEN POLY SPECIFICATION. EACH BAG SHALL BE FILLED TO 20" HIGH WITH 3/8" CLEAN, WASHED, AND SCREENED SAND AND FILLED TO A MINIMUM OF 55LBS.
3. BREAKER SPACING AND CONFIGURATION MAY CHANGE AS DETERMINED BY COMPANY OR SIMILARLY QUALIFIED PROFESSIONAL.
4. ALL MATERIALS SHALL BE SUPPLIED BY CONTRACTOR.
5. INSTALL ONE TRENCH BREAKER UNDER EVERY SLOPE BREAKER.



Figure 10
 Typical Trench Breaker Perspective View
 (OKS-7901-CONST-07)





NOTES

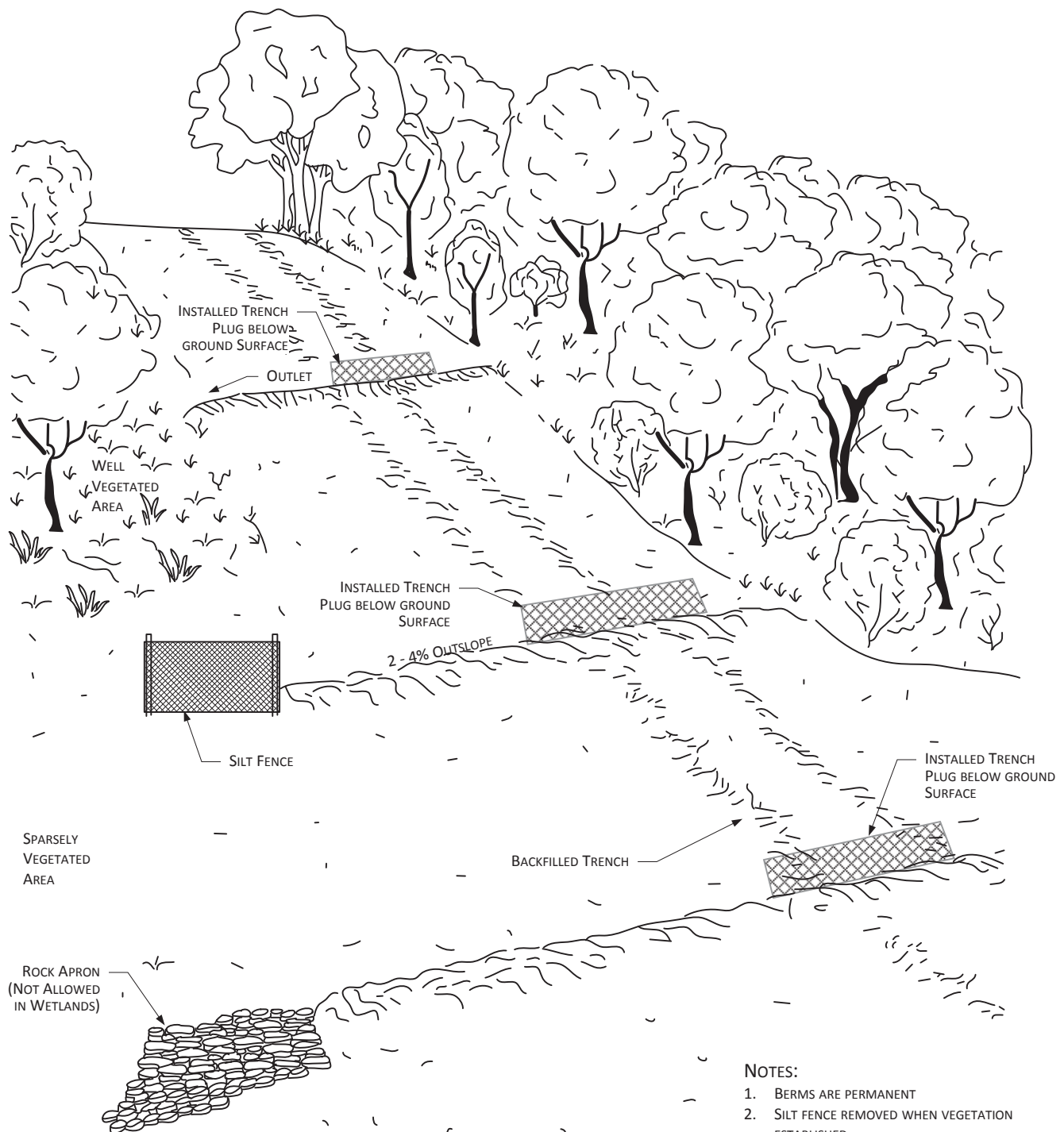
1. BAGS WILL NOT BE FILLED WITH TOPSOIL
2. ADDITIONAL INFORMATION INCLUDED ON OTHER DRAWINGS
3. STAGGER COURSES OF BAGS

For environmental review purposes only.



Figure 11
Typical Trench Breakers
Plan & Profile Views





PERSPECTIVE VIEW
(NOT TO SCALE)

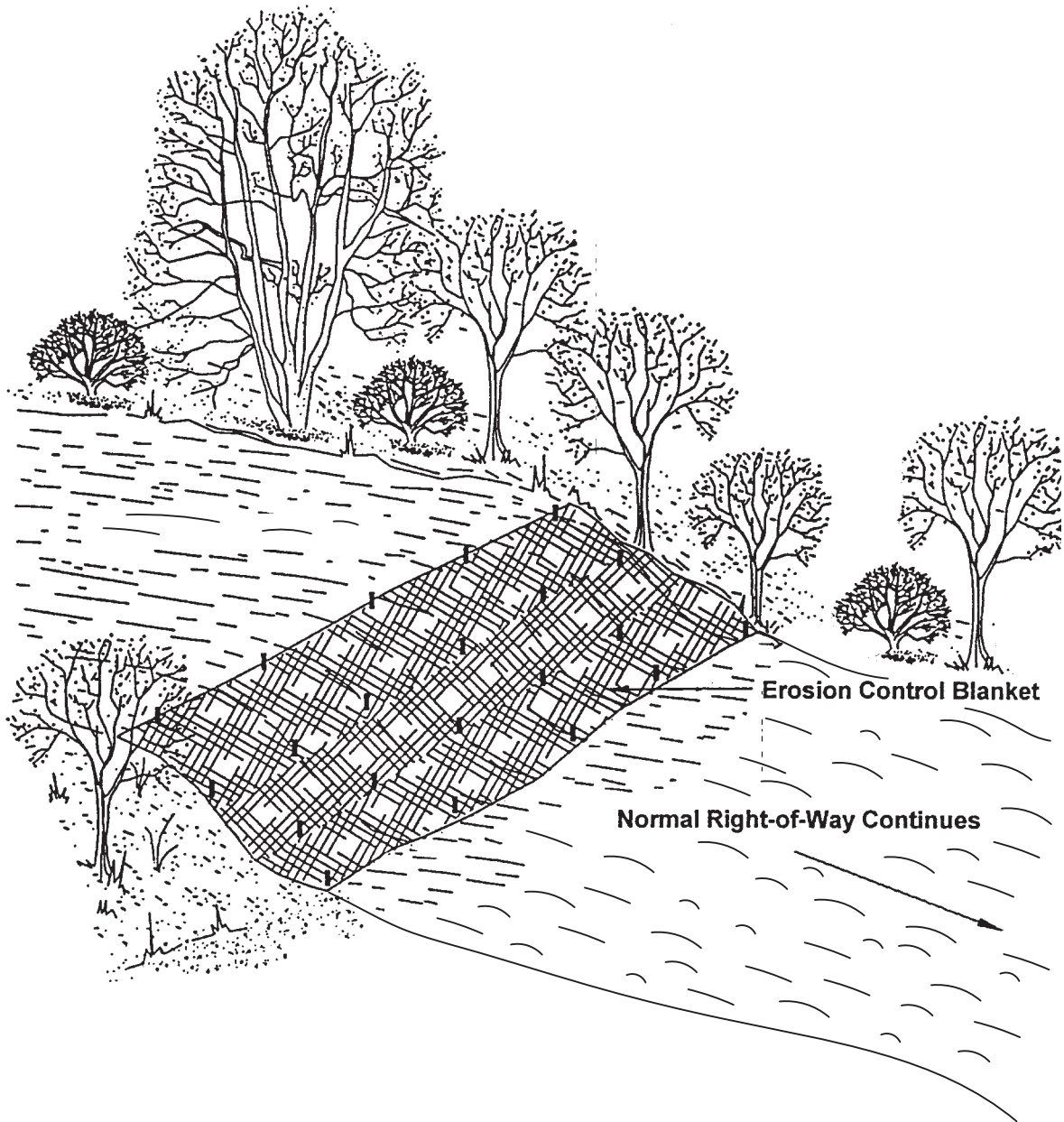
SLOPE %	APPROXIMATE SPACING (FT)
5-15	300
15-30	200
>30	<100

- NOTES:**
1. BERMS ARE PERMANENT
 2. SILT FENCE REMOVED WHEN VEGETATION ESTABLISHED.
 3. LOWEST BERM MAY BE OMITTED IF SILT FENCE OR STRAW BALES ARE INSTALLED AT THAT LOCATION, SUBJECT TO APPROVAL.
 4. INSTALL SILT FENCE OR STRAW BALES AT DISCHARGE END OF EARTHEN BERMS AS NECESSARY TO DISSIPATE ENERGY AND PREVENT EROSION.

For environmental review purposes only.

Figure 12
Permanent Slope Breakers
Perspective View





NOTES

1. INSTALL EROSION CONTROL BLANKET AS PER MANUFACTURER'S SPECIFICATIONS.
2. ADDITIONAL INFORMATION INCLUDED ON OTHER DRAWINGS.

For environmental review purposes only.



Figure 13
Erosion Control Blanket - Steep Slopes ($\geq 30\%$)



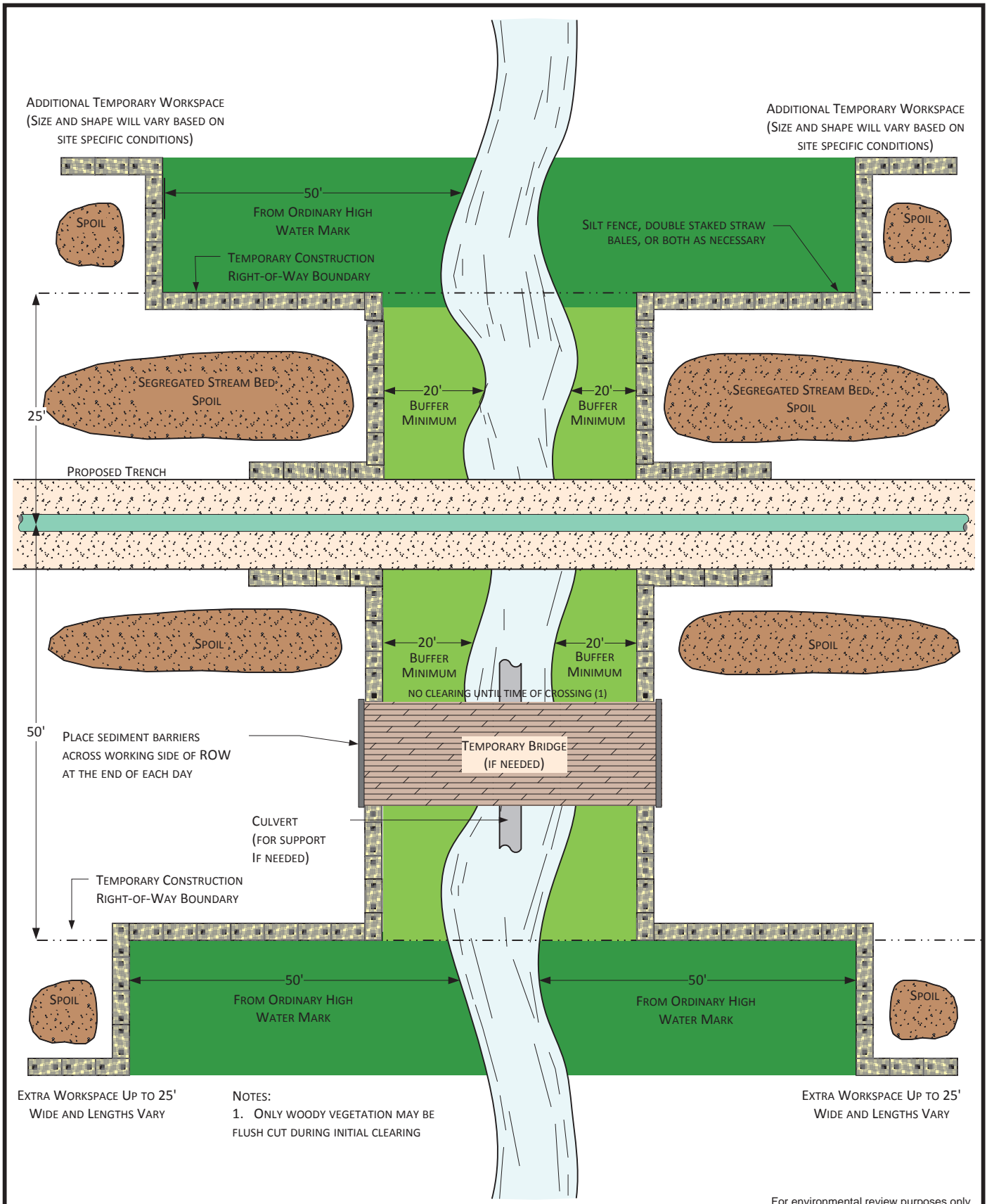


Figure 14
Typical Waterbody Crossing
Open Cut - Wet Trench Method



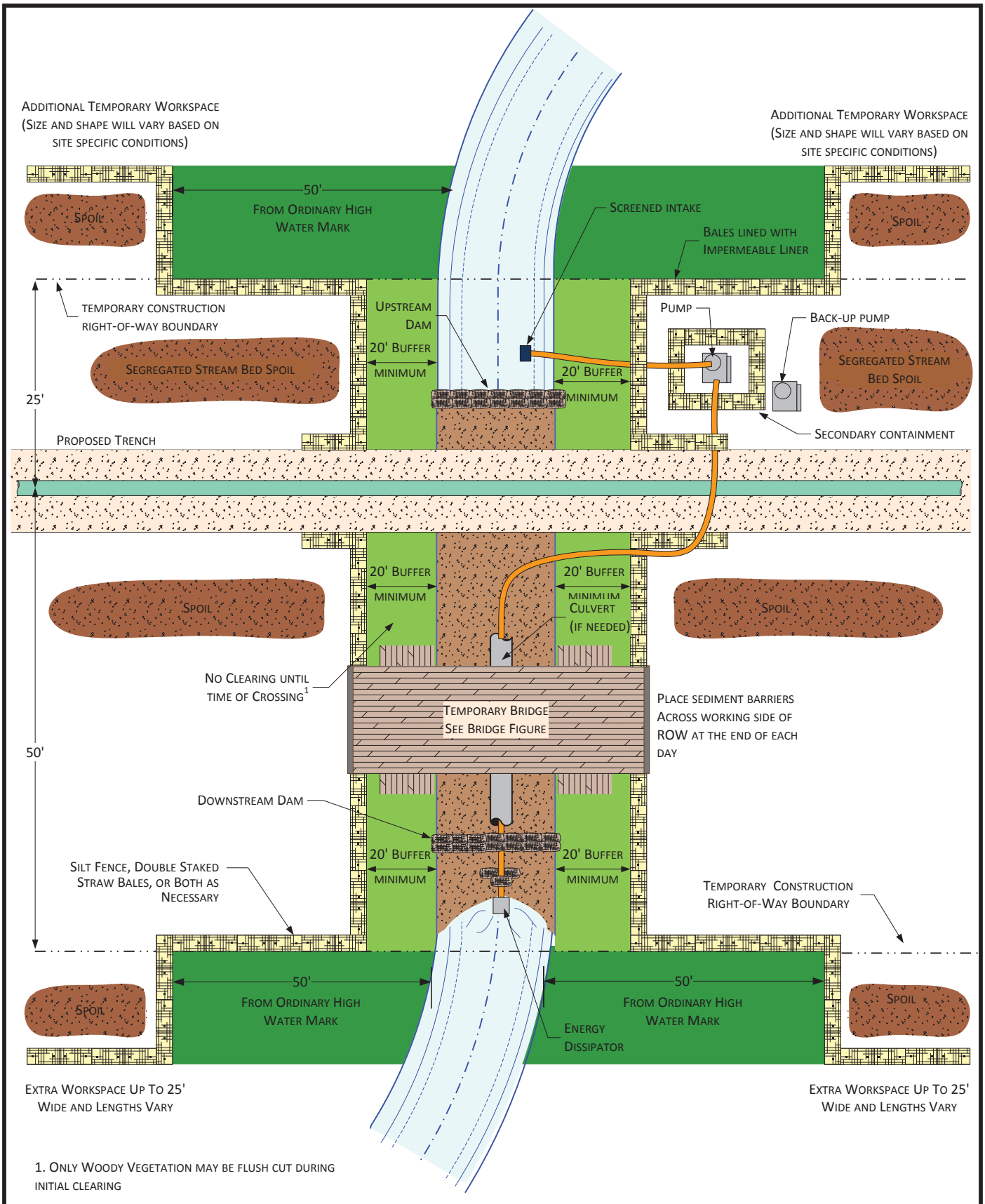


Figure 15
Typical Waterbody Crossing
Dam and Pump Method



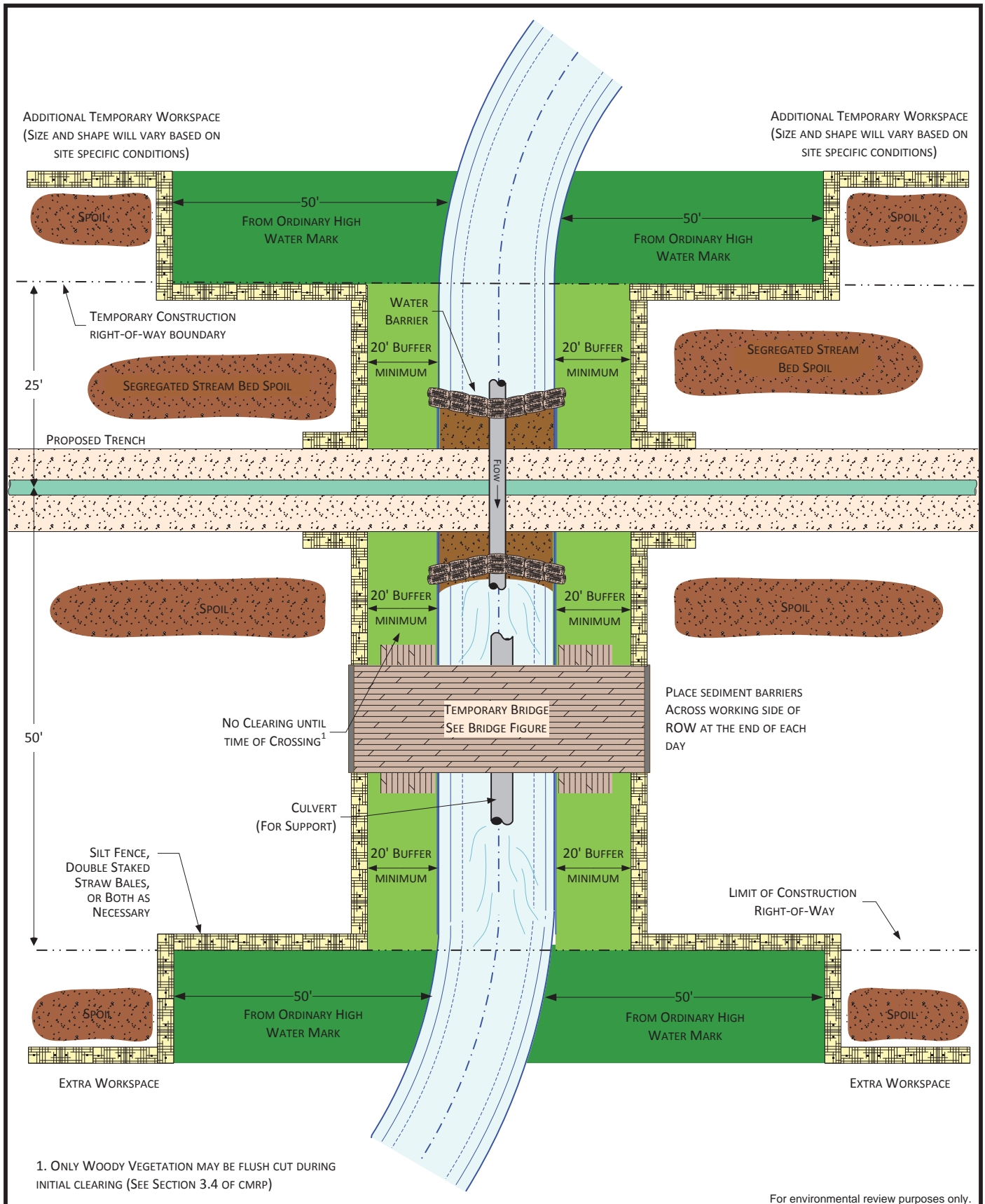
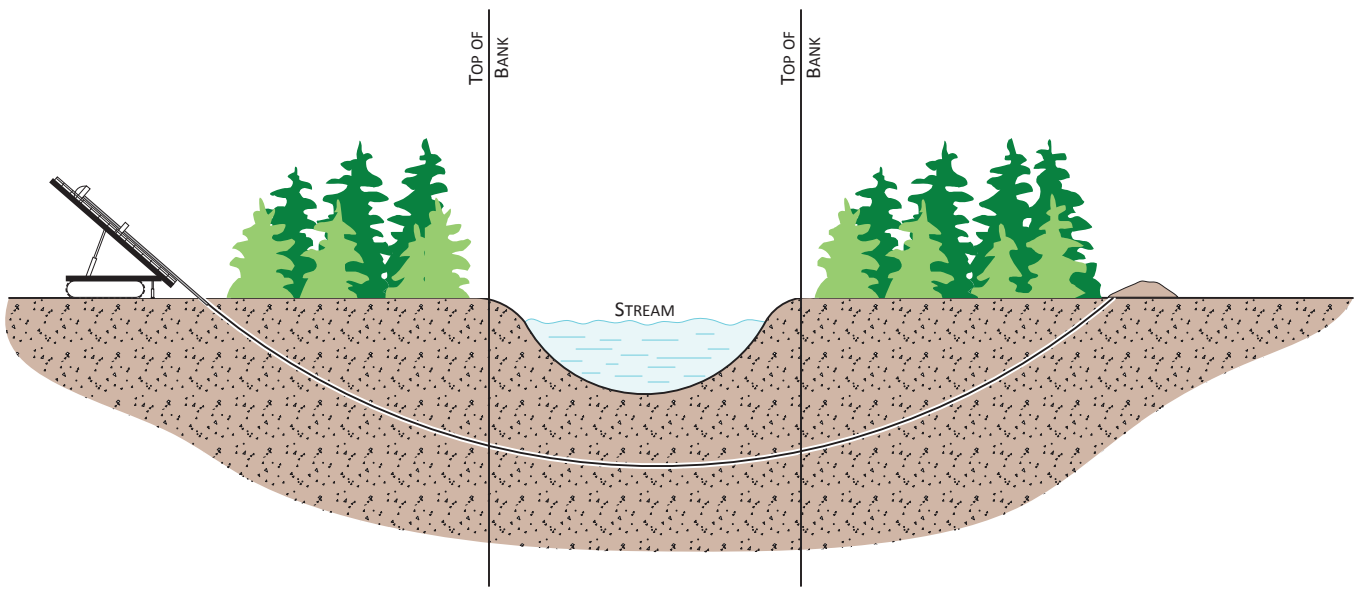


Figure 16
Typical Waterbody Crossing
Flume Method





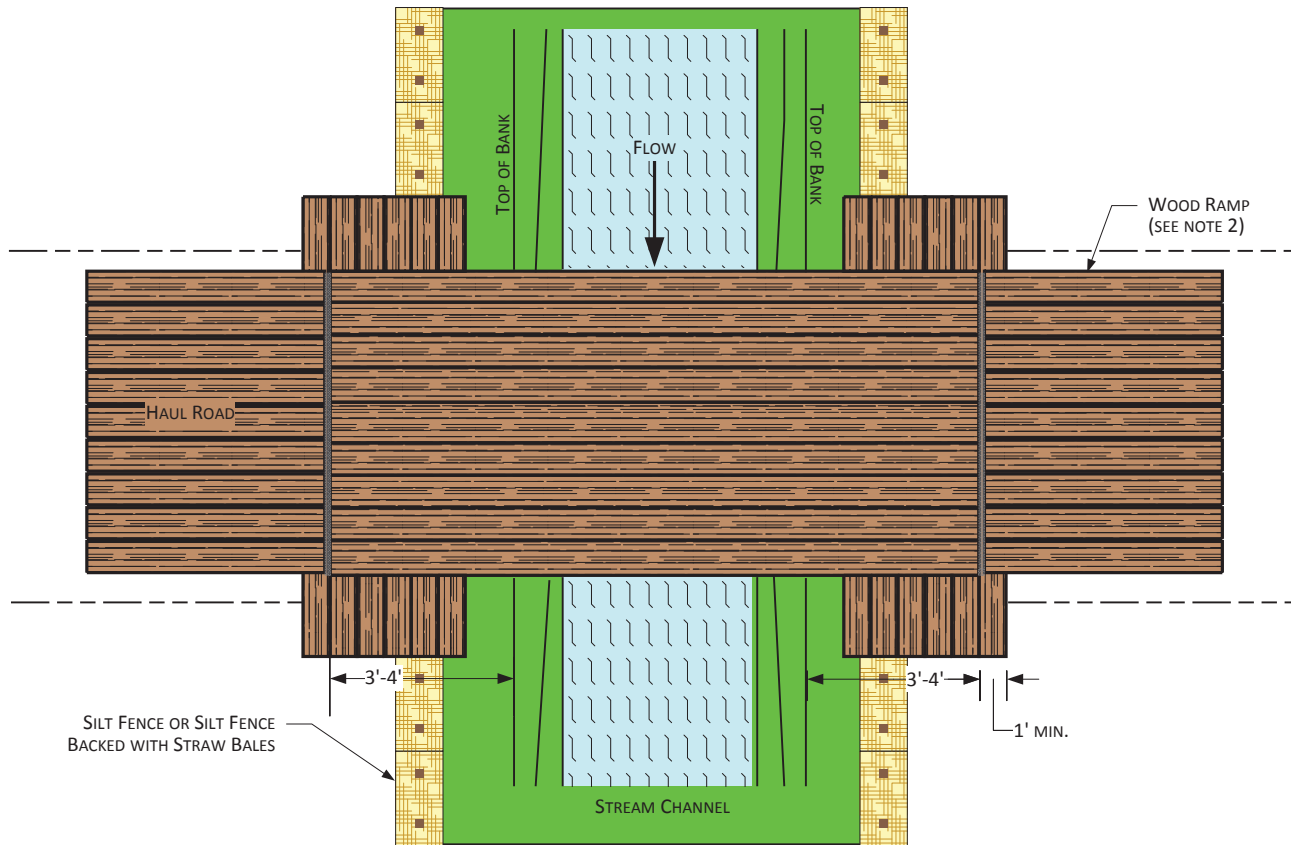
For environmental review purposes only.



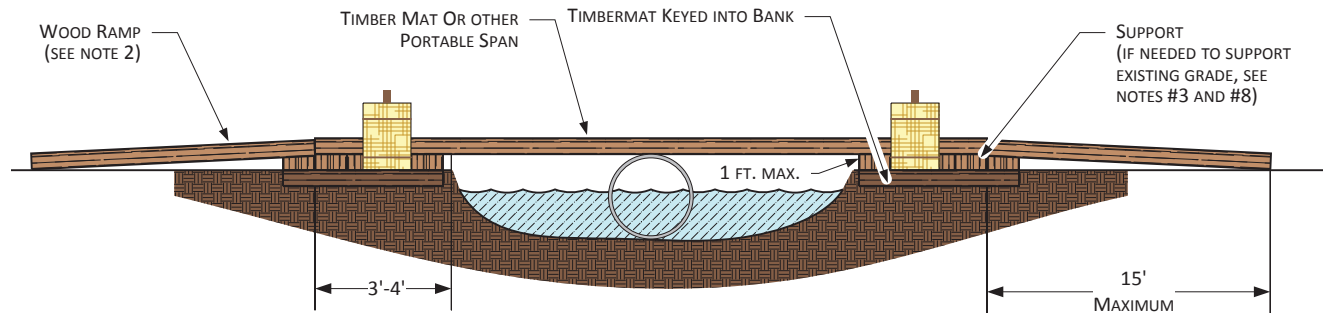
Figure 17
 Typical Waterbody Crossing
 Directional Drill Method



Plan View



Profile View



NOTES:

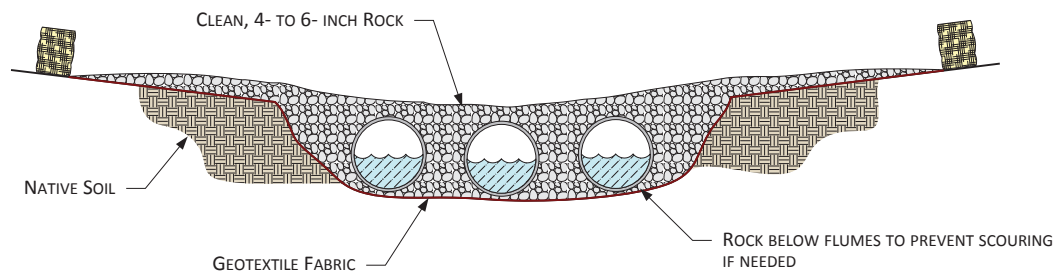
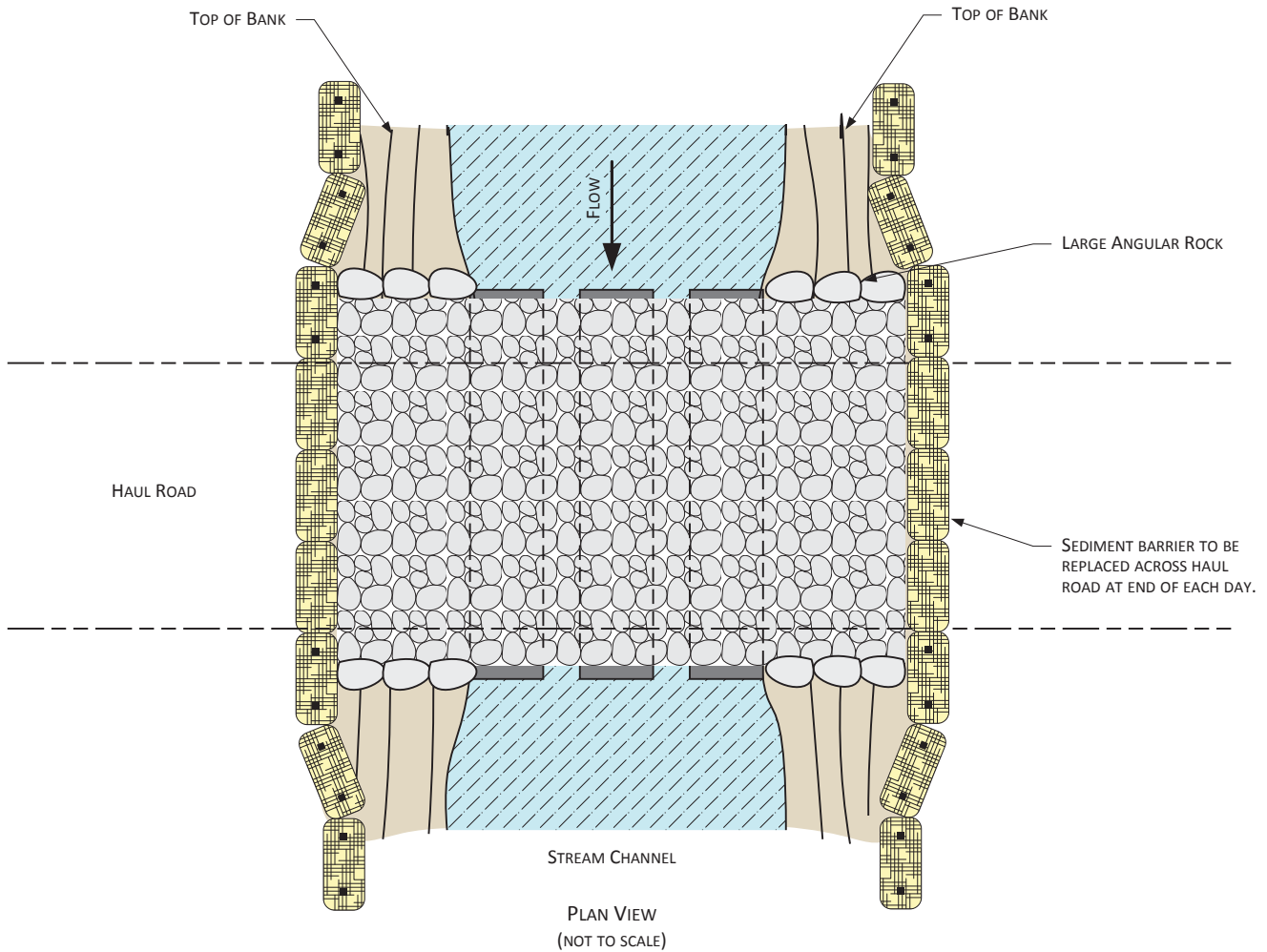
1. INSPECT BRIDGE OPENING PERIODICALLY AND FOLLOWING RAINFALLS OF OVER ½". REMOVE ANY DEBRIS RESTRICTING FLOW AND DEPOSIT IT AT AN UPLAND SITE OUTSIDE OF FLOODPLAIN.
2. IF PHYSICAL CIRCUMSTANCES PROHIBIT WOOD OR METAL RAMPS, EARTHEN RAMPS MAY BE USED AS APPROVED.
3. INSPECT BRIDGE ELEVATION SO BRIDGE REMAINS SUPPORTED ABOVE HIGH BANK AND DOES NOT SINK INTO BANK.
4. THE CULVERT SUPPORT MUST BE ANCHORED TO THE STREAM BOTTOM AND MAY NOT BE SUPPORTED WITH FILL.
5. THE BRIDGE MUST SPAN FROM TOP OF BANK TO TOP OF BANK.
6. ADDITIONAL SUPPORT MUST BE ADDED ON TOP OF BANK AND UNDER SPAN IF INITIAL SUPPORT STARTS TO SETTLE.
7. EROSION AND SEDIMENTATION CONTROL MEASURES SHALL BE INSPECTED AND MAINTAINED IN ACCORDANCE WITH THE COMPANY'S ENVIRONMENTAL MITIGATION PLAN

For environmental review purposes only.



Figure 18
 Typical Span Type Bridge
 With or Without Instream Support
 (OKS-7901-ENV-04)





NOTES:

1. STEEL FLUME PIPE(S) SIZED TO ALLOW FOR STREAM FLOW AND EQUIPMENT LOAD.
2. STRAW BALES (OR EQUIVALENT) SHALL BE PLACED ACROSS BRIDGE ENTRANCE EVERY NIGHT.
3. ADDITIONAL INFORMATION INCLUDED ON OTHER DRAWINGS.

For environmental review purposes only.



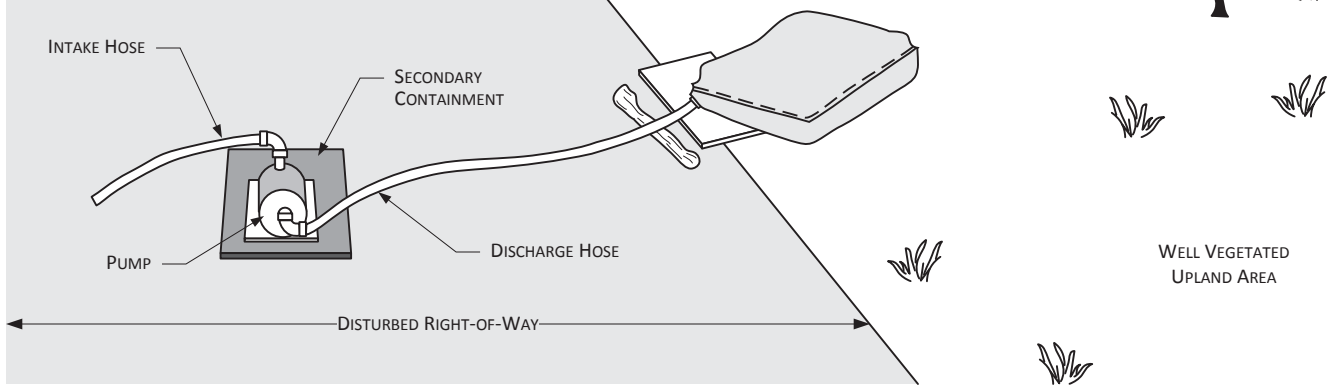
Figure 19
Typical Rock Flume Bridge
Method 4
(OKS-7901-ENV-03d)



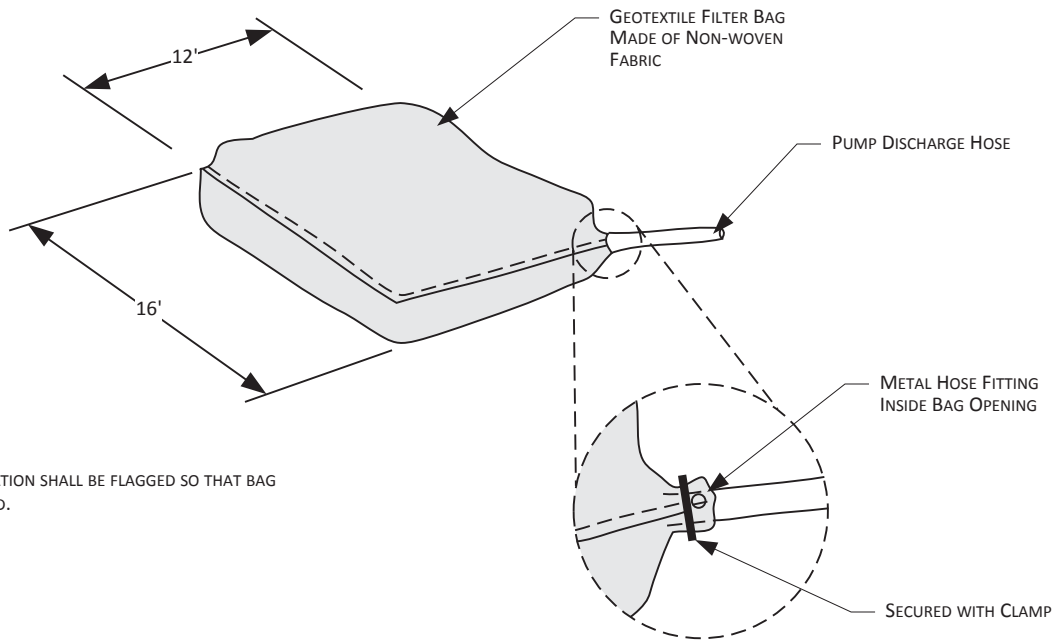
DEWATERING DISCHARGE IN WELL VEGETATED UPLANDS

NOTES:

1. PUMP INTAKE HOSE MUST BE SECURED AT LEAST ONE FOOT ABOVE THE TRENCH BOTTOM.
2. DEWATER INTO GEOTEXTILE FILTER BAG OR STRAW BALE DEWATERING STRUCTURE.



GEOTEXTILE FILTER BAG



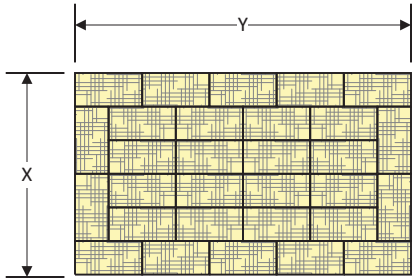
NOTE:

1. FILTER BAG LOCATION SHALL BE FLAGGED SO THAT BAG CAN BE REMOVED.

For environmental review purposes only.

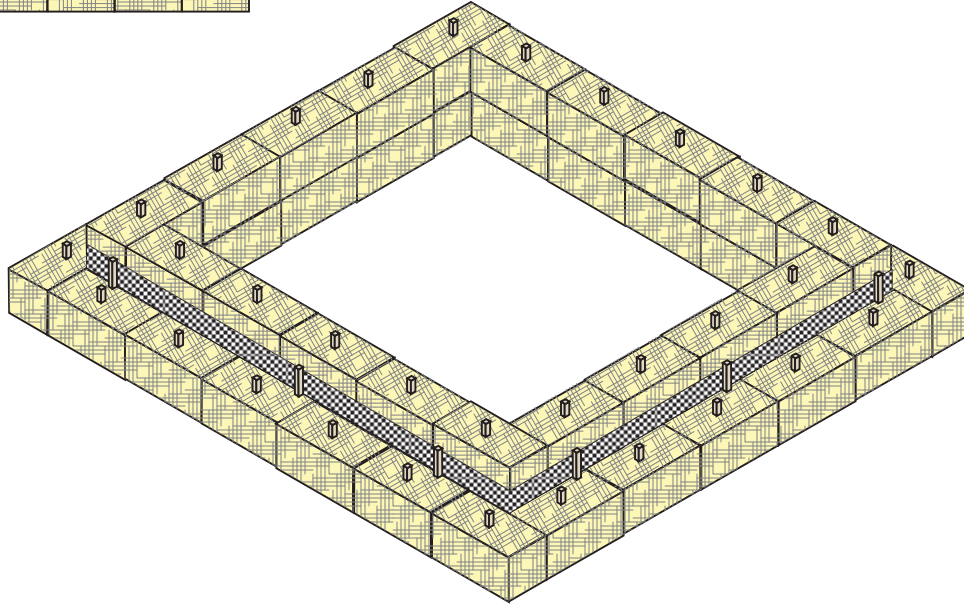
Figure 20
Typical Dewatering Measures



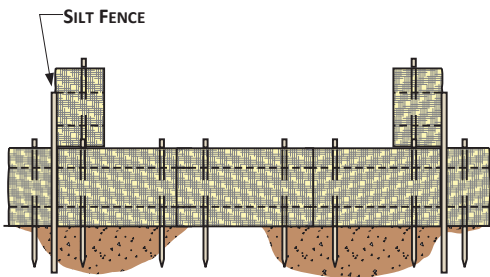


NOTES

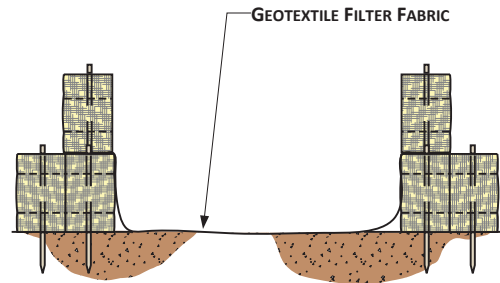
1. ARRANGE THE STRAW BALES TO THE X AND Y DIMENSIONS AS SPECIFIED BELOW.
2. IF BOTTOM OF STRUCTURE IS NOT LINED WITH STRAW BALES (OPTION 1), LINE ENTIRE STRUCTURE WITH GEOTEXTILE FILTER FABRIC.



PERSPECTIVE VIEW



OPTION 1



OPTION 2

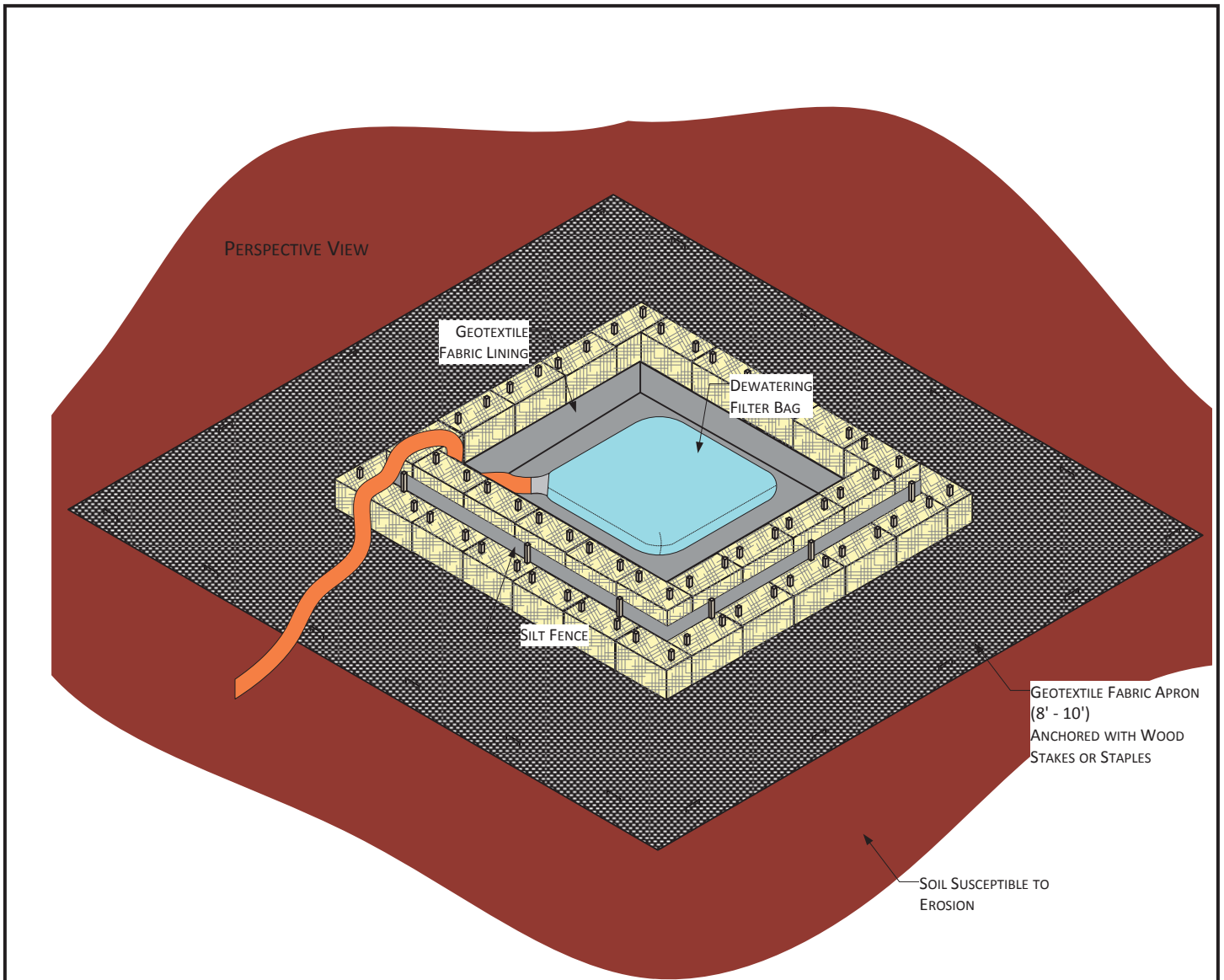
MINIMUM SUMP DIMENSIONS (FEET)		MAXIMUM PUMPING RATE GALLONS PER MINUTE
X	Y	
10	20	300
15	20	350
20	20	400
20	25	450
25	25	500
25	30	550
30	30	660

For environmental review purposes only.

Figure 21

**Straw Bale Dewatering Structure
(OKS-7901-ENV-05)**





CONSTRUCT DEWATERING STRUCTURE TO ACCOMMODATE ANTICIPATED PUMPING RATES. SEE EXAMPLE BELOW.

EXAMPLE PUMPING RATE = 200 G.P.M.

STORAGE VOLUME (C.F.) = 16 X 200 G.P.M. = 3200 C.F.

HEIGHT OF STRAW BALE STRUCTURE = 3 FEET (2 BALES STACKED) (BASED ON HEIGHT OF BALES, NOT SILT FENCE)

INSIDE DIMENSIONS OF STRUCTURE = 33 X 33 FEET SQUARE

NOTES:

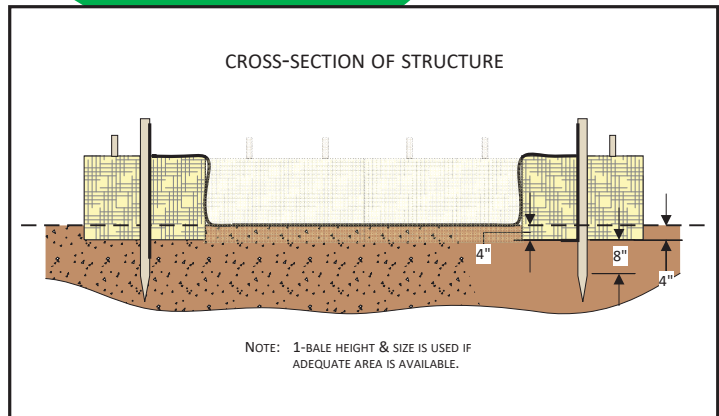
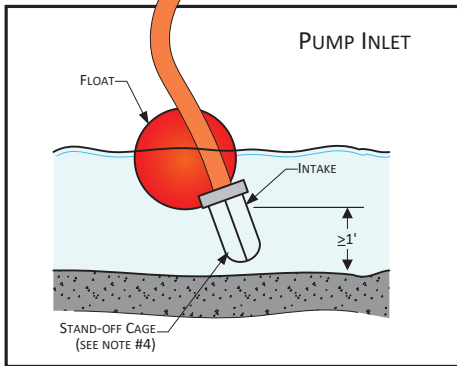
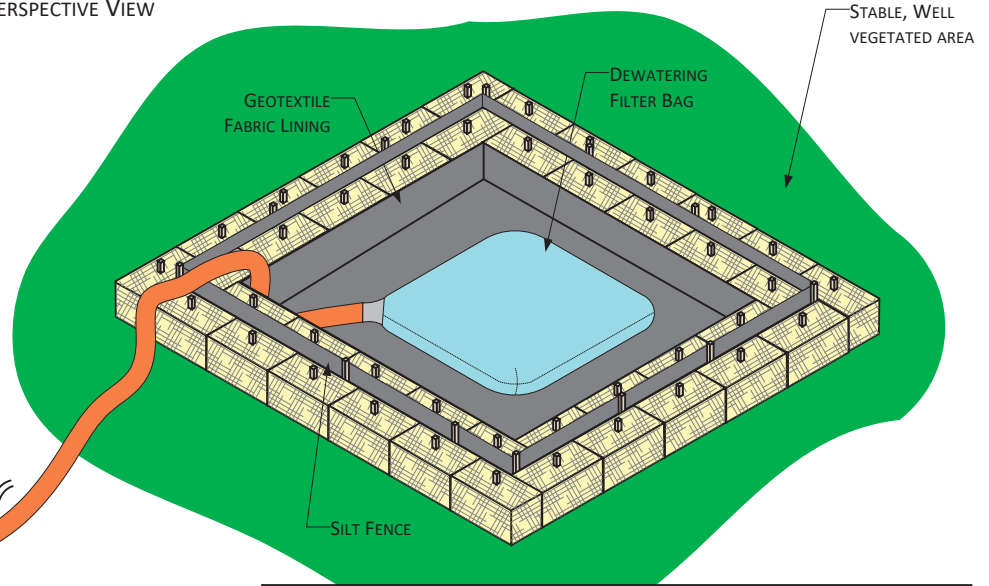
1. SILT FENCE ENDS MUST BE WRAPPED TO JOIN TWO SECTIONS.
2. INSTALL SILT FENCE 2 INCHES ABOVE TOP OF STRAW BALES, AND ANCHOR A MINIMUM OF 8 INCHES STRAIGHT DOWN.
3. SPACING BETWEEN SILT FENCE POST STAKES MUST BE 4 FEET OR LESS.
4. DEWATERING INTAKE HOSE SUPPORTED AT LEAST 1 FOOT FROM BOTTOM OF TRENCH BEING DEWATERED.
5. EROSION AND SEDIMENTATION CONTROL MEASURES SHALL BE INSPECTED AND MAINTAINED IN ACCORDANCE WITH THE COMPANY'S UPLAND EROSION CONTROL, REVEGETATION, AND MAINTENANCE PLAN.

For environmental review purposes only.

Figure 22
Straw Bale Dewatering Structure
(OKS-7901-ENV-06a)



PERSPECTIVE VIEW



CONSTRUCT DEWATERING STRUCTURE TO ACCOMMODATE ANTICIPATED PUMPING RATES. SEE EXAMPLE BELOW.

EXAMPLE PUMPING RATE = 200 G.P.M.
 STORAGE VOLUME (C.F.) = 16 x 200 G.P.M. = 3200 C.F.
 HEIGHT OF STRAW BALE STRUCTURE = 1.5 FEET (1 BALE) (BASED ON HEIGHT OF BALES, NOT SILT FENCE)
 INSIDE DIMENSIONS OF STRUCTURE = 46 x 46 FEET SQUARE

NOTES:

1. SILT FENCE ENDS MUST BE WRAPPED TO JOIN TWO SECTIONS.
2. INSTALL SILT FENCE 2 INCHES ABOVE TOP OF STRAW BALE, AND ANCHOR A MINIMUM OF 8 INCHES STRAIGHT DOWN.
3. SILT FENCE POST STAKING MUST BE 4 FEET OR LESS.
4. DEWATERING INTAKE HOSE SUPPORTED AT LEAST 1 FOOT FROM BOTTOM OF TRENCH BEING DEWATERED.
5. USE A FILTER BAG AT THE DISCHARGE HOSE END.
6. EROSION AND SEDIMENTATION CONTROL MEASURES SHALL BE INSPECTED AND MAINTAINED IN ACCORDANCE WITH THE COMPANY'S CMRP.

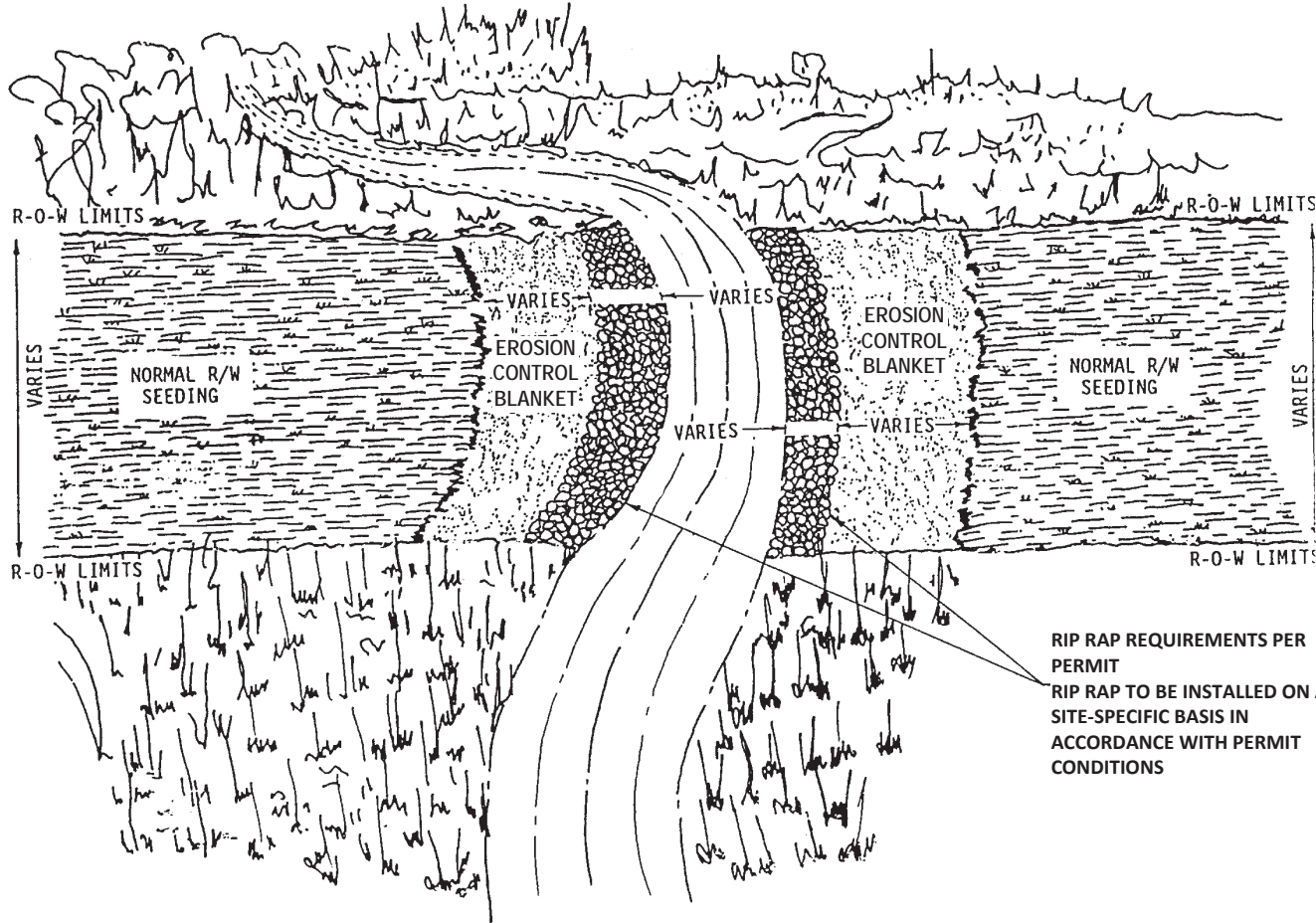
For environmental review purposes only.



Figure 23
Straw Bale Dewatering Structure
(OKS-7901-ENV-06b)



NOTE: PLACE EROSION CONTROL BLANKET A MINIMUM OF ONE (1) FOOT UNDER RIP RAP. EXTEND JUTE BLANKET FROM MEAN HIGH WATER LEVEL TO SEVERAL FEET BEHIND HIGH BANK.



For environmental review purposes only.

Figure 24
 Typical Final Stream Bank Stabilization
 Rip Rap & Erosion Control
 (OKS-7901-ENV-07)



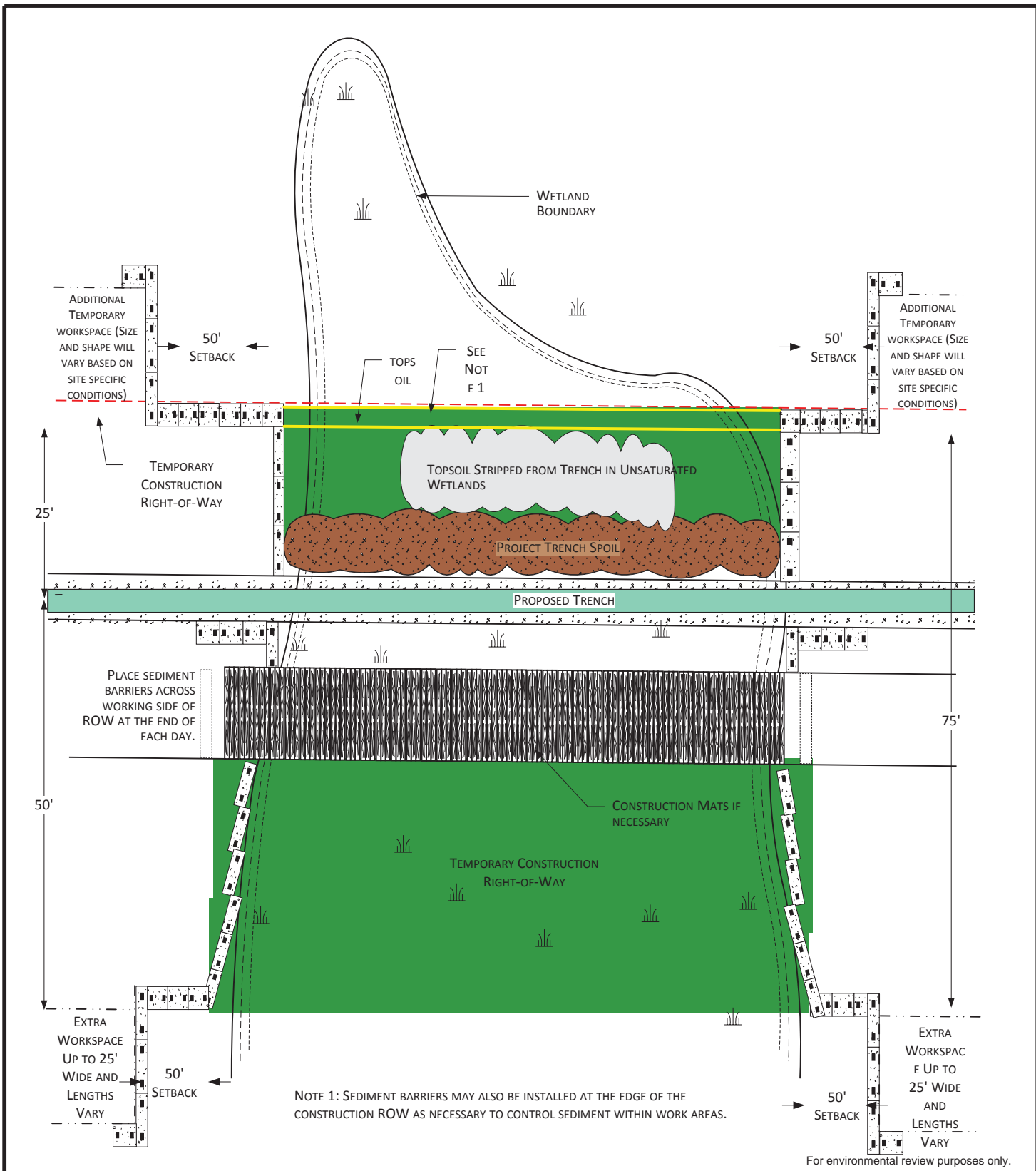
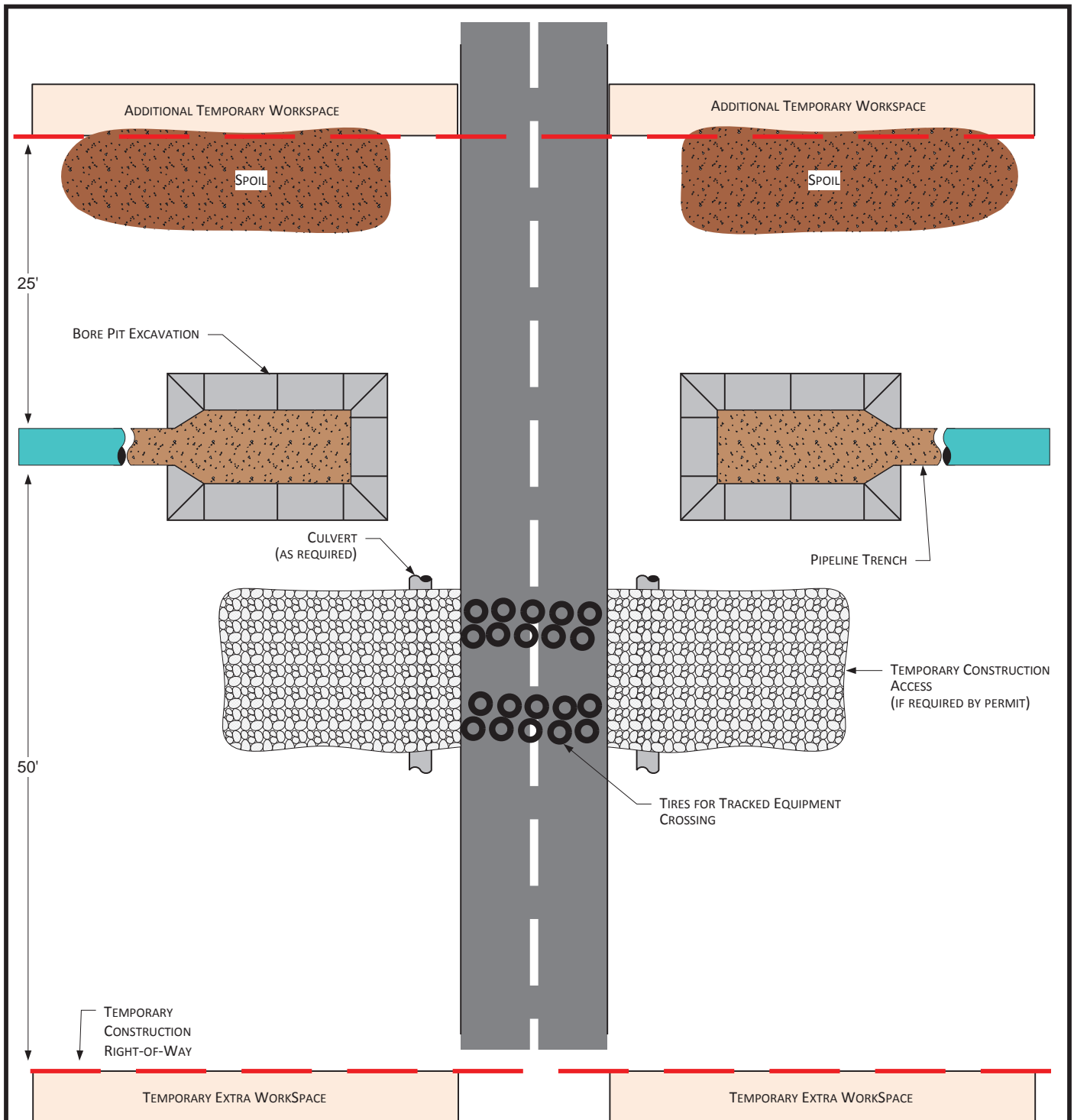


Figure 25
 Typical Wetland Crossing Method
 Method 5
 (OKS-7901-ENV-03e)





PLAN VIEW

NOTES

1. PROCEDURES SHOWN IN THIS DRAWING APPLY TO IMPROVED ROADS.
2. ROADS MUST BE CLEANED AFTER EQUIPMENT CROSSES AND DIRT PLACED IN SPOIL CONTAINMENT AREAS.
3. TEMPORARY ACCESS MATERIALS MUST BE REMOVED UPON PROJECT COMPLETION.
4. ADDITIONAL INFORMATION INCLUDED ON OTHER DRAWINGS OR PERMITS.
5. CONSTRUCTION AREAS LOCATED OUTSIDE ROAD ROW.
6. INSTALL EROSION AND SEDIMENT CONTROLS AS NEEDED BASED ON SITE SPECIFIC CONDITIONS

For environmental review purposes only.



Figure 26
Typical Improved Road Crossing
Directional Bore Method

