

February 22, 2021

Via Electronic Mail

Mr. Steve Kahl
Executive Director
North Dakota Public Service Commission
600 E. Boulevard, Dept. 408
Bismarck, ND 58505-0480
ndpsc@nd.gov

**In re: Expedited Request for Authorization for Topsoil Removal
ONEOK Bakken Pipeline, L.L.C.
Pump Station Additions
Dunn & McKenzie Counties
Case No. PU-20-018
Our File No. 072591-000006**

Dear Mr. Kahl:

On behalf of ONEOK Bakken Pipeline, L.L.C. ("ONEOK"), electronic copies of this Expedited Request for Authorization for Topsoil Removal and the following attachments are enclosed for filing in the above-referenced matter:

- Attachment 1 Big Gulch Pump Station Grading Plan;
- Attachment 2 Caterpillar RM500B Brochure; and,
- Attachment 3 The INGAA Foundation, Inc. Report No. 2013.04, "Planning Guidelines for Pipeline Construction During Frozen Conditions," December 2013.

On February 3, 2021, the Commission issued Findings of Fact, Conclusions of Law and Order in Case No. PU-20-018 amending Certificate of Corridor Compatibility No. 184 and Route Permit No. 194 for the addition of two pump stations along ONEOK's existing Bear Creek Natural Gas Liquids Pipeline. The Order incorporates the Commission's Certification Relating to Order Provisions which contains various provisions related to topsoil segregation and removal. Specifically, Certification Relating to Order Provision No. 11 requires Commission approval for removal of frozen topsoil.

On February 16, 2021, ONEOK and Commission staff held a preconstruction conference for construction of the seven-acre Big Gulch Pump Station located in Dunn County. ONEOK provided notice of its intent to commence construction beginning on February 22, 2021. ONEOK intends to remove topsoil, grade the site, and lay rock across the entire Big Gulch Pump Station site to support the permanent infrastructure and accommodate site access. On February 19 Commission staff subsequently indicated that Commission approval of ONEOK's construction methods would be required prior to removing frozen topsoil. Therefore, ONEOK submits this Expedited Request for Authorization for Topsoil Removal and respectfully requests the Commission grant ONEOK's request authorizing removal of frozen topsoil at the Big Gulch Pump Station. ONEOK's proposed methodology to remove frozen topsoil is detailed below.

The first step in segregating the topsoil across the site will be a survey of soil layers to determine depth to topsoil to ensure the appropriate amount of topsoil is captured across the site. Since the topsoil depth may vary, a total of twelve (12) boring samples will be taken at multiple locations uniformly across the site up to 24" in depth. ONEOK will use a skid steer with an auger attachment to perform the bores. Results of the topsoil survey will be utilized to create a depth-of-topsoil profile across the entire site to ensure proper segregation. The proposed placement of boring samples is depicted by red circles on the ONEOK Grading Plan, attached hereto as Attachment 1.

Based on the topsoil profile, ONEOK proposes to utilize a Caterpillar RM500B (see brochure enclosed as Attachment 2 hereto) to cut to the needed depth of topsoil. This equipment was chosen for two primary reasons. It has the capability to cut through frozen soils and has settings that allow adjustable depths to ensure it is set for appropriate segregation of soils. ONEOK believes the proposed methods are acceptable means of topsoil segregation and are consistent with industry standards governing winter topsoil removal as set forth in The INGAA Foundation, Inc. Report No. 2013.04, "Planning Guidelines for Pipeline Construction During Frozen Conditions," December 2013 ("INGAA") (Attachment 3 hereto), which guidance documentation has been previously accepted by the Commission. ONEOK's proposed use of the Caterpillar RM500B is consistent with the methods recommended in the INGAA report outlining mechanical methods such as multiple passes with a bulldozer, soil rippers, or other specialized equipment to remove only the topsoil.

Once the topsoil is cut and removed, it will be stockpiled on site should the site be subsequently reclaimed. Some topsoil will be used later to reclaim disturbed areas not receiving rock as final grade. ONEOK plans to stockpile the topsoil on the south end of the site (see bubbled area on Attachment 1). Stockpile will have the proper Erosion Control Devices to ensure the topsoil is properly maintained.

Construction crews are on standby until authorization is received for topsoil removal to occur. For the reasons outlined herein, and as set forth in the attachments, good cause exists for the Commission to approve ONEOK's expedited request.

Please feel free to contact me if you have any questions. Thank you.

Sincerely,



Wade C. Mann

WCM/lh

Enc.

cc: Casey Furey (via email)
Michael Dailey (via email)
Victor Schock (via email)
Brian Johnson (via email)

NOTES:

- STRUCTURAL FILL MATERIAL SHALL ALSO BE USED TO BACKFILL INSIDE THE GRADE BEAMS
- STRUCTURAL FILL MATERIAL MAY BE USED FOR BACKFILL OUTSIDE THE GRADE BEAMS, HOWEVER, THE TOP 24" MINIMUM SHALL BE CLAY MATERIAL TO MINIMIZE WATER INFILTRATION

GRADING NOTES:

- ON-SITE SOILS APPEAR SUITABLE FOR RE-USE AS GENERAL FILL. CONTRACTOR SHALL BE PREPARED TO EXCAVATE, HANDLE, AND EXPORT UNSUITABLE MATERIAL (AS DEFINED BY GENERAL NOTES).
- FRAGMENTS OF ROCK AND SOIL UP TO 2 INCHES IN MAXIMUM DIMENSION MAY BE INCLUDED IN GENERAL FILL.
- IMPORTED FILL MATERIAL SHALL CONSIST OF RELATIVELY IMPERVIOUS SOILS THAT HAVE 80 PERCENT OR LESS PASSING THE NO. 200 SIEVE AND PLASTICITY INDEX OF 20 OR LESS. REPRESENTATIVE SAMPLES OF THE MATERIAL SHALL BE TESTED AND APPROVED PRIOR TO TRANSPORT TO THE SITE.
- SELECT FILL MATERIAL SHALL BE CLASSIFIED AS SW, SW-SM, SW-SC, SP, SP-SM, SP-SC, SM, OR SC IN ACCORDANCE WITH USCS CLASSIFICATION SYSTEM WITH LESS THAN 25% PASSING @#200 SIEVE AND 100% PASSING @ 2" SIEVE.
- MATERIAL CLASSIFIED AS FAT CLAYS (CH), SHALES, LIGNITES, AND CLAYSTONE SHALL NOT BE USED.
- FILL SLOPES SHALL BE OVERBUILT AND CUT BACK TO DEVELOP AN ADEQUATELY COMPACTED SLOPE FACE.
- ALL CONTOUR LABELS AND ELEVATION CALLOUTS ARE IN FEET AND REFERENCE TOP OF AGGREGATE ELEVATIONS (FINISHED GRADE).
- CONTRACTOR SHALL REMOVE AND ADJUST THE ELEVATION OF THE EXISTING ACCESS ROAD TO MEET PROPOSED PUMP PAD.
- CONTRACTOR SHALL REPAIR ACCESS DRIVE AND YARD SURFACE AREA AFTER CONSTRUCTION ACTIVITIES ARE COMPLETE.
- GRADE SURFACE PROFILE AS REQUIRED TO ACCOMMODATE LOW GROUND CLEARANCE FOR DELIVERY TRAILER.
- CONTRACTOR SHALL PROVIDE AND INSTALL EROSION CONTROL DEVICES IN ACCORDANCE WITH LOCAL, STATE, AND FEDERAL REQUIREMENTS.
- ALL SILTATION AND EROSION CONTROL DEVICES SHALL REMAIN IN PLACE UNTIL ADEQUATE VEGETATIVE GROWTH ENSURES NO FURTHER SOIL EROSION.
- CONTRACTOR SHALL PRESERVE ALL STAKED FENCE CORNERS.
- CONTRACTOR SHALL GRADE AS REQUIRED AROUND THE PROPOSED ELECTRICAL ENCLOSURE LOCATION TO PROVIDE AMPLE ROOM FOR CRANE OPERATION DURING DELIVERY OF THE ELECTRICAL ENCLOSURE.
- DEPENDING UPON EXISTING SOIL CONDITIONS, SOME AREAS OF THE SITE MAY BE SUSCEPTIBLE TO EROSION. CONTRACTOR SHALL INSTALL PERMANENT EROSION CONTROL DEVICES AS NECESSARY TO PREVENT EROSION.
- SELECT FILL LIMITS SHALL BE A MINIMUM OF 2' BEYOND EDGE OF FOUNDATION.

EARTHWORK QUANTITIES:

CUT: 10,714.4 CUBIC YARDS
 FILL: 11,821.9 CUBIC YARDS
 NET (FILL): 1,107.5 CUBIC YARDS

NOTE: EARTHWORK QUANTITIES PROVIDED ARE APPROXIMATE AND DO NOT ACCOUNT FOR STRIPPING TOPSOIL SHRINKAGE FACTORS, BULK FACTORS, OR UNSUITABLE MATERIALS ENCOUNTERED. QUANTITIES DO NOT INCLUDE WORK ASSOCIATED WITH THE ACCESS ROAD.

2"x2"x24" HARDWOOD STAKE @ 4' O.C. (24" #6 REBAR WITH CAP MAY BE SUBSTITUTED AT CONTRACTOR'S OPTION)

DIRECTION OF FLOW

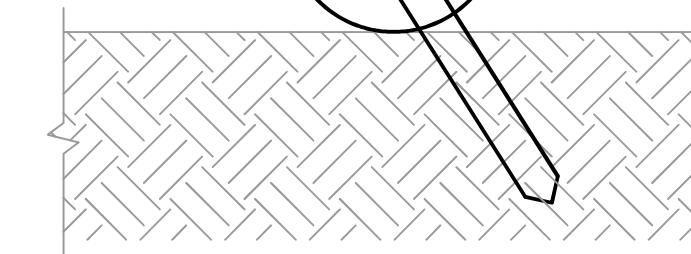

NOTES:

- WHEN FIBER LOG IS INSTALLED AT TOP OF SLOPE, CENTER LINE OF LOG SHALL BE 1'-FT FROM TOP OF SLOPE.

FIBER LOG TEMPORARY EROSION CONTROL DETAIL
 NOT TO SCALE

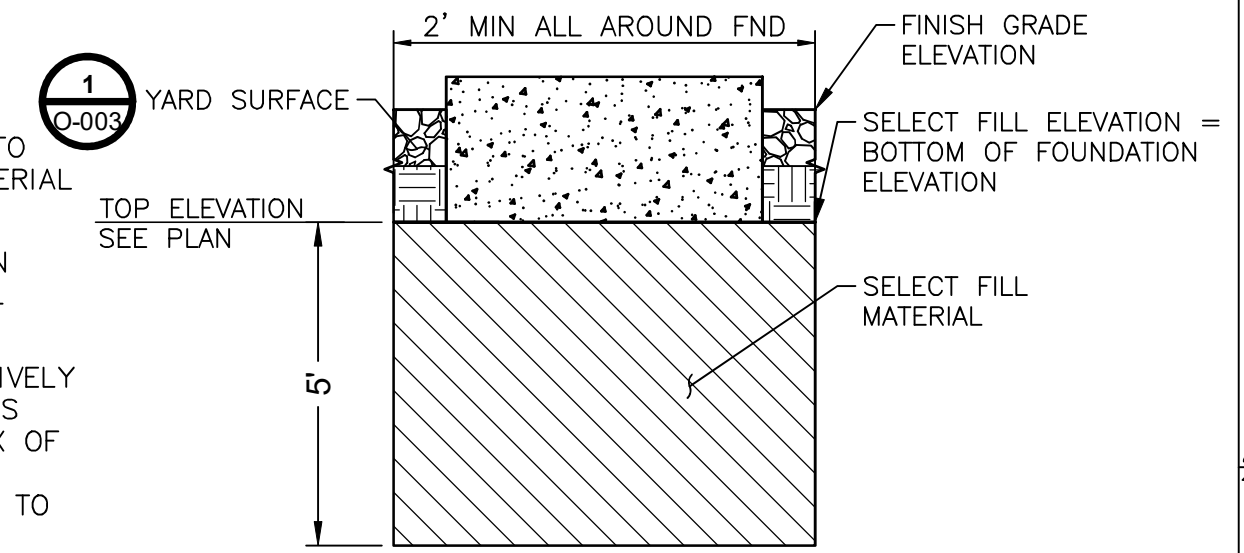
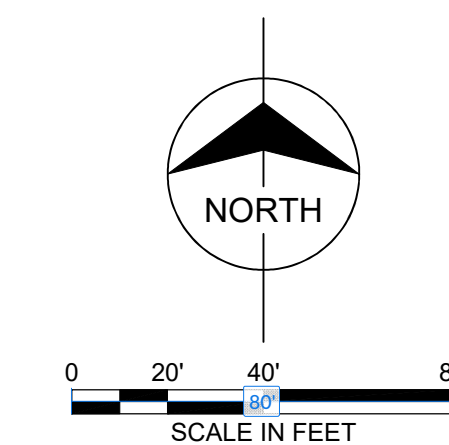

SELECT FILL UNDER SHALLOW FOUNDATIONS
 NOT TO SCALE

NOTES:

- SELECT FILL MATERIAL SHALL ALSO BE USED TO BACKFILL INSIDE THE GRADE BEAMS.
- STRUCTURAL FILL MATERIAL MAY BE USED FOR BACKFILL OUTSIDE OF THE GRADE BEAMS. HOWEVER, THE TOP 24 INCHES (MINIMUM) SHALL BE CLAY MATERIALS TO MINIMIZE WATER INFILTRATION INTO THE SELECT FILL

LEGEND:

- EXISTING CONTOUR (1.0 FT INTERVAL)
- PROPOSED CONTOUR (1.0 FT INTERVAL)
- 2.00% SLOPE DIRECTION ARROW
- EXISTING SPOT ELEVATION
- PROPOSED SPOT ELEVATION
- SILT FENCE
- FIBER LOG
- SELECT FILL
- 36" MIN FENCE POST (10' MAX CENTER TO CENTER)
- FILTER CLOTH
- UNDISTURBED GROUND
- FLOW
- EMBED FILTER CLOTH MIN 6" INTO GROUND

CONSTRUCTION NOTES FOR FABRICATED SILT FENCE:

- FILTER CLOTH SHALL BE FASTENED SECURELY TO POSTS.
- JOIN FILTER CLOTH AT A POST WITH 6" FOLDED OVERLAY OVERLAP.
- SILT FENCE SHALL BE INSPECTED AFTER EVERY RAINFALL EVENT AND AT INTERVALS AS REQUIRED BY THE STORM WATER POLLUTION PREVENTION PLAN. MAINTENANCE SHALL BE PERFORMED AS NEEDED AND SILT MATERIAL REMOVED WHEN "BULGES" DEVELOP IN THE SILT FENCE.
- SILT FENCE MAY BE INSTALLED BY SPECIALITY MACHINE AT CONTRACTOR'S OPTION.
- TERMINATE ENDS UP-SLOPE TO PREVENT FLOW-AROUND.

POST: STEEL EITHER "T" OR "U" TYPE OR 2" HARDWOOD
 FILTER FABRIC: FILTER X, MIRAFI 100X, STABILINKA T140N OR APPROVED EQUAL.
 PREFABRICATED UNIT: GEOFAB, ENVIROFENCE, OR APPROVED EQUAL.

SILT FENCE DETAIL



13 Mar 2020 BURNS & MCDONNELL ENGINEERING CO., INC.
 NORTH DAKOTA LICENSE NO.016PE



MK	DATE	REVISIONS	BY	AP.	MK	DATE	REVISIONS	BY	AP.
0	02/14/20	ISSUED FOR BID	TAB	JBB					
1	03/13/20	ISSUED FOR CONSTRUCTION	TAB	JBB					

NOTICE
 This drawing has not been published and is the property of ONEOK PARTNERS LP, 100 W. FIFTH ST., TULSA, OKLA., and is loaned to the borrower for his confidential use only; and in consideration of the loan of this drawing the borrower promises and agrees that it shall not be reproduced, copied, loaned, or otherwise disposed of directly or indirectly, nor used for any purpose other than for which it is specifically furnished.

DWG. NO.	REFERENCE DRAWINGS



BEAR CREEK PIPELINE BIG GULCH-794 GRADING PLAN			
DES.: BRP	AFE#: ####	DATE: 02/13/20	
DR.: TAB	REFIN. JOB#: ####	DWG. NO.:	
CH.: JAL	SCALE: 1:40	794-0-004	1
AP.: JBB	CAD#: 794-0-004		

CAT[®] RM500B

ROTARY MIXER



RM500B

TECHNOLOGY SIMPLIFIES OPERATION, INCREASES PRODUCTION AND ASSURES QUALITY.

Enhancements and versatility make this durable industry workhorse an exceptional value. High production and excellent production quality go hand-in-hand with low operating and maintenance costs. Rotor and spray system options provide the ability to adapt to a wide range of applications.

- SUPERIOR MIX QUALITY
- SIMPLE TO OPERATE
- OPERATOR IS COMFORTABLE AND IN CONTROL
- EASY TO SERVICE
- ENHANCED PROPEL SYSTEM
- HIGHLY VERSATILE



1. Cat® C15 ACERT™ Engine
2. Reversible Variable Speed Fan
3. Sliding Cab
4. Electronically Controlled Full Time All-wheel Drive
5. Roll Over Protection Structure (ROPS)
6. Remote Grease Fittings
7. Pivoting, Heated Operator's Seat with Integrated LCD Touchscreen Display, Control Console and Handwheel Steering
8. Front Remote Camera
9. Rear Remote Camera
10. Mixing Chamber Remote Camera (option)
11. Rooding Lights (option)
12. Automatic Load Control
13. Water Pump System (option)
14. Emulsion Pump System (option)
15. Direct Rotor Drive
16. Three Rotor Options: Universal, Combination, Soil
17. Variable Volume Mixing Chamber
18. Torque Limiter (option)
19. Rotating Amber Beacon (option)
20. Product Link™ (option)
21. Mirror Package (option)
22. Storage for Bits, etc.
23. Bolt-on Counterweight (option)
24. Maintenance-free Cat Batteries



A well-appointed cab provides the operator with a quiet, uncluttered work environment. Everything is within reach and everything is within view, allowing the operator to focus on work, maximizing productivity.



COMFORT AND CONTROL

THE OPERATOR COMES FIRST.



1. LCD Touchscreen Display
2. Backlit Control Keypad
3. Propel Lever with Thumb Control Buttons
4. Pivoting Adjustable Heated Seat
5. Handwheel Steering Control
6. Remote Camera Monitor
7. 12-volt Power Receptacle
8. Seatbelt
9. Emergency Stop
10. Horn
11. Enable/Disable Regeneration
12. Cupholder
13. Remote Camera System Toggle
14. Climate Controls
15. Speakers for Customer-installed Radio



Seat rotates 180 degrees for enhanced comfort and visibility

FINGERTIP CONTROL

A HIGH PRODUCTION WORKSPACE.

PROPEL LEVER THUMB CONTROLS

1. Rotor Up
2. Rotor Down
3. Rotor Travel Mode (Full up)
4. Rotor Automatic Depth Set Point (set and return)
5. Mixing Chamber Rear Door Raise
6. Mixing Chamber Rear Door Lower



OPERATOR'S CONSOLE KEYPAD CONTROLS

7. Cruise Control - Increase Speed
8. Cruise Control - Decrease Speed
9. Travel Mode
10. Throttle Control
11. Steering Mode Select
12. Spray System Control
13. Cab Slide Left
14. Rear Steer Left
15. Front Mixing Chamber Door Raise
16. Front Mixing Chamber Door Close
17. Mixing Chamber Service Mode/Chamber Float
18. Chamber Tilt Back
19. Rotor Speed
20. Rotor Control
21. Cab Slide Right
22. Rear Steer Right



EXCELLENT VISIBILITY

The RM500B features a sliding cab and rotating seat to provide the operator with an unimpeded view of the cutting path on either side of the machine. Standard front and rear remote cameras supplement the view, and an optional remote camera provides views to the rear door of the mixing chamber so the operator can monitor mix quality.

HEAVY-DUTY POWERTRAIN

GETS THE JOB DONE EFFICIENTLY AND RELIABLY.



ABOVE: In Europe, Canada and the United States, the RM500B comes with a C15 ACERT engine equipped with an emissions module (CEM) that meets Tier 4 Final/Stage IV emission standards.

BELOW: In regions without emission standards, the RM500B is equipped with a C15 ACERT engine that meets Tier 3/Stage IIIA emission standards.



CAT ENGINES DELIVER SMOOTH POWER WITH FEWER EMISSIONS

In the United States, Canada and Europe, the RM500B is equipped with a Cat C15 ACERT engine, a turbocharged, 6-cylinder diesel engine that provides 407 kW (546 hp) of gross power. The engine is designed to meet US EPA Tier 4 Final and EU Stage IV emissions standards. Every Tier 4 Final/ Stage IV Cat engine with ACERT Technology is equipped with a combination of proven electronic, fuel, air and aftertreatment components. Applying proven technologies systematically lets us meet our customer's high expectations for productivity, fuel efficiency, reliability and service life.

In regions without emission standards, the RM500B is powered by a Cat C15 ACERT engine, a turbocharged, 6-cylinder diesel engine that provides 403 kW (540 hp) of gross power. ACERT Technology utilizes an electronic controller to precisely deliver multiple injections of fuel. These multiple injections are combined with a refined air management system in order to generate fewer emissions and optimize fuel combustion while achieving emissions levels equivalent to Tier 3 and Stage IIIA emission standards.

A robust cooling system provides cool air intake to maximize fuel efficiency and minimize emissions. An on-demand variable speed fan draws ambient air from a separate compartment in front of the engine through the cooling package. The exhaust air exits from the front of the machine, maintaining a cool engine compartment.

The cooling fan is reversible and automatically performs periodic cycles in reverse to clean the heat exchanger by expelling accumulated dust. This allows the system to cool more efficiently, ensuring that the engine is working optimally. A sensor prevents accidental overheating during a reverse cycle.

FOUR STEERING MODES

ALL-WHEEL DRIVE AND FOUR STEERING MODES PROVIDES SURE TRACTION, PRECISE SPEEDS AND HIGH MANEUVERABILITY

Standard electronically controlled all-wheel drive and four steering modes maximize traction and mobility even in poor conditions. The all-wheel drive system continually monitors and balances pressures for maximum traction.

The RM500B is fully hydrostatically driven and features four independent pumps and drive motors. The four pumps provide a dedicated flow to each wheel motor, ensuring sufficient power for traction. Sensors adjust hydraulic flow to balance traction, reducing wheel spin indicative of loss of traction and ensuring that the machine propels in even the most extreme conditions.

Propel is controlled with an electronic joystick on the operator's console. The propel joystick has six thumb buttons that allow the operator to conveniently adjust the rear chamber door trim, manually adjust the rotor depth, and also make a rotor depth set-point for consistent depth when a certain depth is repeatedly required or automatically elevate the rotor for Travel Mode.

The propel system provides four steering modes: Front Steer, Rear Steer, Crab Steer and Coordinated Steer. The ability to change the steering characteristics of the machine provides high maneuverability.

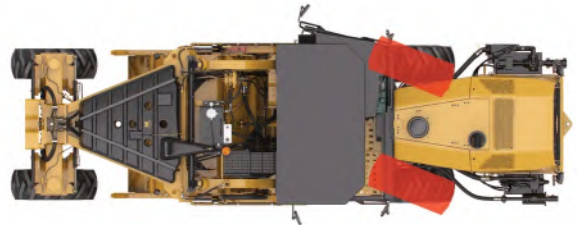

Front Steer Mode

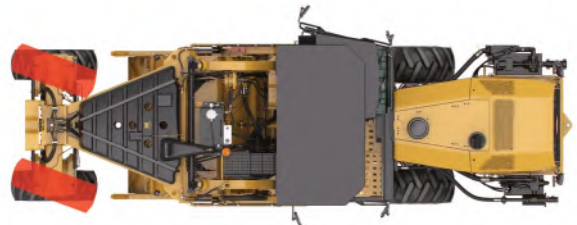

Rear Steer Mode

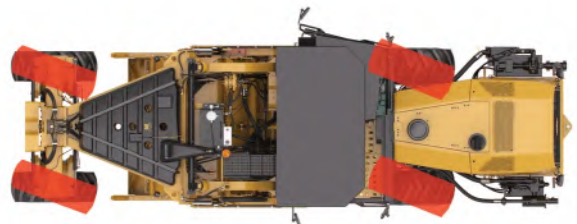

Crab Steer Mode

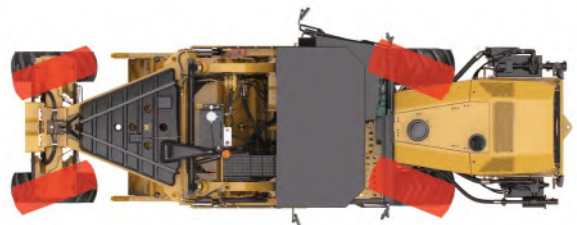

Coordinated Steer Mode



VERSATILITY ALLOWS **MULTIPLE USES**

Three rotor choices and three rotor speeds powered by a sturdy rotor drive system provide the means to perform a multitude of applications. Combined with four steering modes and electronically controlled full time all wheel drive, the RM500B is a go-anywhere, do-anything machine.

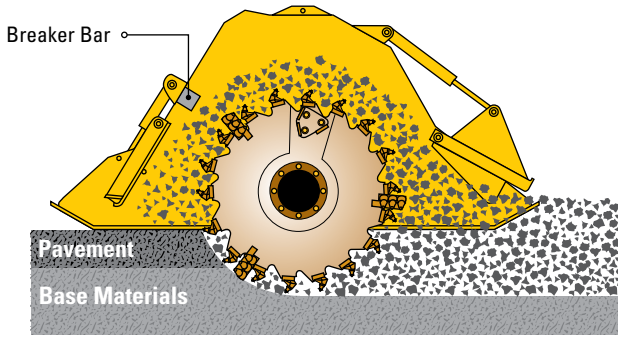

FULL DEPTH RECLAMATION:

In-place full depth reclamation offers a cost-effective means to recycle the material without the time and expense of removing and replacing it. Existing pavements are pulverized in place along with a portion of the existing base materials to form a new homogenous base. Reclamation also provides the opportunity to introduce water or emulsions, and other virgin aggregates to improve the material design. The result is a new, stronger, more uniform base. Compared with the costs of other rehabilitation methods—overlay or reconstruction—reclamation is the most economical choice over the life of the rehabilitated road.

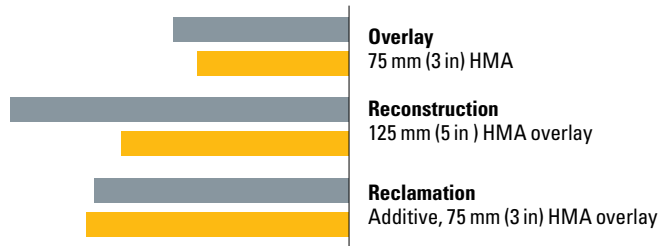

Relative Unit Cost
Per square meter (yard)

Estimated Service Life
Years

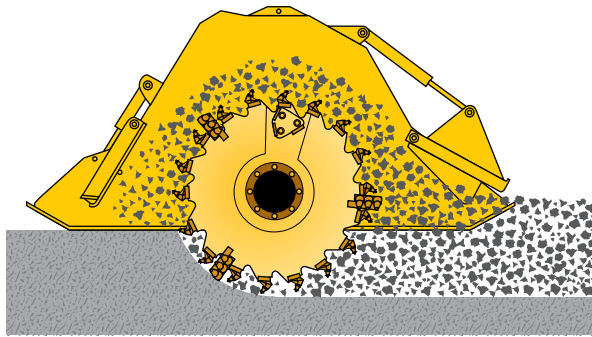

SOIL STABILIZATION:

Soil stabilization is the process of mechanically or chemically improving the load-bearing characteristics of the soil. Additives such as fly ash, Portland cement and lime are incorporated into cohesive and semi-cohesive native soil to increase compressive strength or reduce plasticity of the subgrade. When performed with the correct additives, stabilization can greatly increase the integrity of the subgrade and provide a material that will have greater support capabilities and moisture resistance.

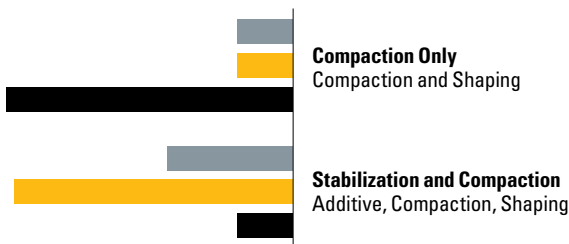

Relative Unit Cost
Per square meter (yard)

Estimated Service Life
Years

Relative Maintenance Cost
Over life of road

OTHER APPLICATIONS:

- Surface Mining
- Agriculture
- Bio-remediation
- Haul Roads
- Aggregate Sizing

ROTOR OPTIONS

DESIGNED FOR EFFICIENT PRODUCTION.

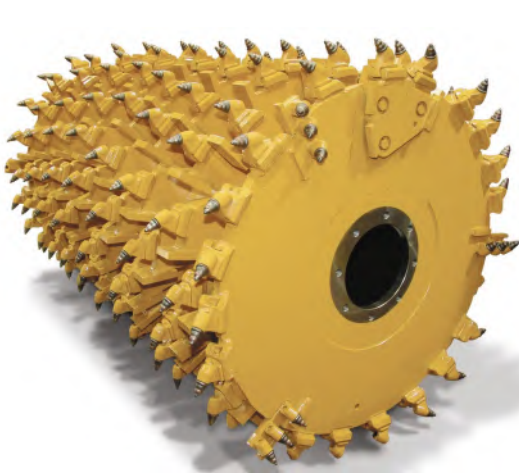

UNIVERSAL ROTOR

Note: Universal Rotor offering dependent on region. Consult your dealer for specifics.

Universal Rotor 16" (41 cm) for asphalt is designed to produce maximum breakout force in severe asphalt cuts and on existing soil cement. The kicker paddle design provides material movement and suspension in the mixing chamber for achieving excellent gradation in full-depth reclamation applications. It may also be used in soil stabilization applications; however, the 200 bit design may result in gradation that is finer than desirable. The large number of bits, along with the kicker paddles, will also cause this rotor to consume the most power for soil applications.

Universal Rotor 18" (46 cm) is designed to provide maximum mixing depth. It has lower breakout force compared to the Universal Rotor 16". This rotor is available only in Europe and it meets European 45 cm mixing depth requirements while providing the highest level of material pulverization and gradation. It has a secondary application of light asphalt reclamation, where the asphalt layer is thin and deteriorated.

Universal Rotors come with Breaker Bars to optimize material sizing.



COMBINATION ROTOR

Designed primarily for stabilization applications in cohesive soils, the Combination Rotor excels in deep-cut soil mixing applications where pulverization and gradation is of lesser importance than higher working speeds. Performs well in cohesive soils and has a secondary application of surface mining for non-engineered substances such as coal, shale, or limestone. Also can handle light reclamation applications where the asphalt layer is thin and deteriorated.

The design utilizes a smaller number of bits, which contributes to lower costs associated with bit replacement. This rotor design results in high production—especially in deep cuts—because less power is required to drive a rotor with fewer bits compared to a rotor with significantly more.

The Combination Rotor will produce larger material sizing compared to the Soil Rotor due to the smaller number of bits.

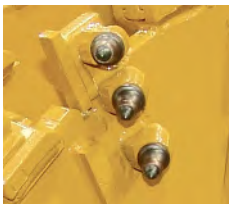

Triple-tree cutting bit placement on rotor ends cleans up loose material and reduces wear on the rotor caused by maneuvering in the cut.

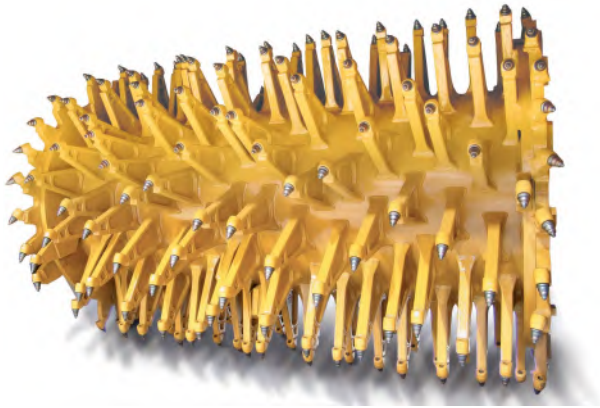

SOIL ROTOR

Designed primarily for soil stabilization applications in semi-cohesive or granular soils, the Soil Rotor is an ideal choice for mixing additives with semi-cohesive or granular materials where soil gradation is critical.

The rotor is equipped with cast stand-offs that include bit holders in a single casting. Worn or damaged bit holders can be removed and replaced with weld-on bit holders. Bit life varies depending on soil type.

Bolt-on Breakaway Cutting Bit Holder

Used on Universal Rotor

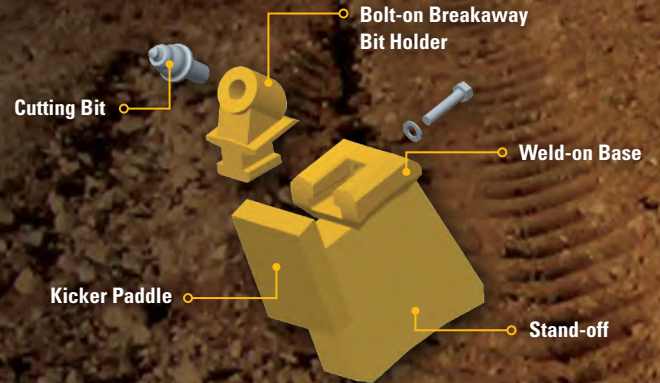

Bolt-on Breakaway Cutting Bit Holder

Used on Combination Rotor

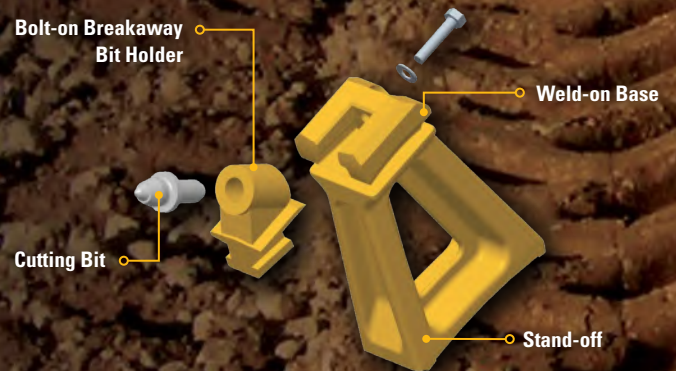

Weld-on Cutting Bit Holder

Used on Soil Rotor and Spade Rotor

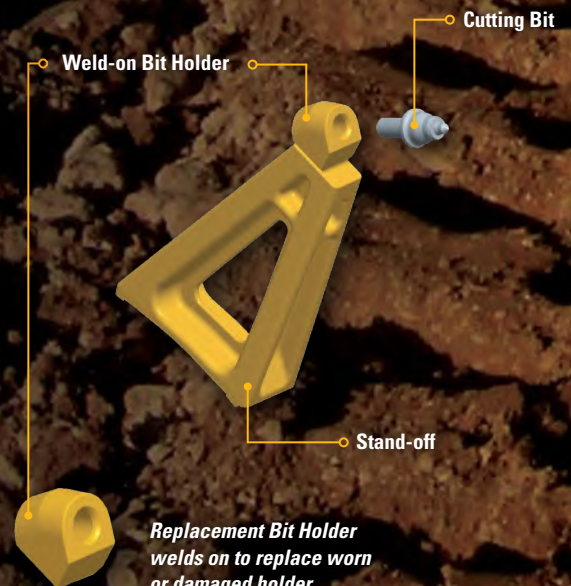



MAXIMIZE PERFORMANCE

CHOOSE THE BEST ROTOR FOR THE APPLICATION

Cat rotors are capable of producing good results in many applications, but each is designed to provide maximum efficiency and productivity when performing a specific application. This chart provides general guidance when choosing a rotor or ascertaining the performance of a rotor for a particular application.

Job Type	Specific Application	Universal 16	Universal 18	Combination	Soil
Reclamation	Full-Depth Asphalt				
	Thin Asphalt Layer 25-75 mm (1-3 in)	●	●	◐	◐
	Medium Asphalt Layer 75-175 mm (3-7 in)	●	●	◐	○
	Thick Asphalt Layer 175-250 mm (7-10 in)	●	◐	○	○
	Soil and Cement (fully cured)	●	●	◐	○
Soil	Mixing/Stabilization				
	Granular Soils	●	●	◐	●
	Granular with rocks < 130 mm (5"), debris	●	●	◐	○
	Light Clay	◐	◐	●	●
	Heavy Clay/Gumbo	○	○	●	◐
Surface Mining	Coal	◐	◐	●	○
	Shale	◐	◐	●	○
	Limestone	◐	○	●	○
Rental	General Purpose	●	◐	●	○

- Rotor is an ideal choice for specific application
- ◐ Rotor performance is acceptable, but not ideal
- Rotor is not recommended for this application

	Universal 16	Universal 18	Combination	Soil
Cut Width	2438 mm (96 in)	2438 mm (96 in)	2438 mm (96 in)	2438 mm (96 in)
Rotor Diameter (over bits)	1375 mm (54 in)	1525 mm (60 in)	1625 mm (64 in)	1625 mm (64 in)
Maximum Depth	406 mm (16 in)	457 mm (18 in)	508 mm (20 in)	508 mm (20 in)
Weight	4080 kg (9,000 lb)	4355 kg (9,600 lb)	3085 kg (6,800 lb)	3855 kg (8,500 lb)
Number of Cutting Bits	200	200	114	238
Bit Impact Spacing	15.9 mm (0.625 in)	15 mm (0.6 in)	32 mm (1.25 in)	11.5 mm (0.45 in)
Bit Holder Type	Bolt-on Breakaway	Bolt-on Breakaway	Bolt-on Breakaway	Weld-on
Bit Shank Diameter	19 mm (¾ in)	19 mm (¾ in)	22 mm (⅞ in)	19 mm (¾ in)
Direction of Cut	Up	Up	Up	Up

CUTTING BIT COMPATIBILITY

Optimize performance for maximum productivity.

Choosing the best cutting bit for your application can optimize the efficiency of the machine, resulting in more production with ideal material sizing and mixing quality. The charts here can help you choose cutting bits based on their suitability for various common reclamation, stabilization and mining tasks.

For more information or cutting tool alternatives, please consult your local Cat dealer or refer to the *Cutter Bit Reference Guide* (PEBJ0011).



117-3884



316-6084



415-3935



149-5763

Part No	Rotor Type		
	UNIVERSAL 19 mm (¾ in) Shank	STABILIZATION 19 mm (¾ in) Shank	COMBINATION 22 mm (⅞ in) Shank
117-3884			x
316-6084			x
149-5763	x	x	
415-3935	x	x	

Part No	Application				Depth		
	Soil	Surface Mining Harder Materials	Surface Mining Softer Materials	Asphalt Reclamation	Shallow 25-50 mm (1-2 in)	Moderate 75-125 mm (3 - 5 in)	Deep +150 mm (+6 in)
117-3884	x				x		
316-6084	x					x	x
149-5763		x				x	x
415-3935	x		x	x	x	x	x



- | | | |
|--------------------------------|--|--|
| 1. Reversing Cooling Fan | 6. Engine Coolant Level Visual Indicator | 11. Hydraulic Oil Level Visual Indicator |
| 2. Remote Grease Fittings | 7. Main Power Switch | 12. LCD Touchscreen |
| 3. Fuel/Water Visual Indicator | 8. Jump-start Stud | 13. Bit Storage Bin |
| 4. Engine Oil Dipstick | 9. Fuse Panel | |
| 5. Air Filter | 10. Maintenance-free Cat Batteries | |

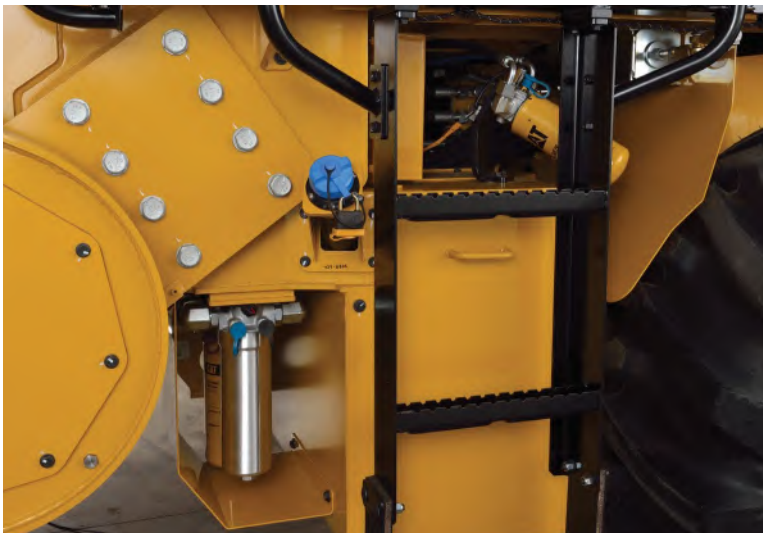

LEFT:
Easy access to hydraulic filters and DEF fill port

SIMPLE TO SERVICE

MAXIMIZING UPTIME MAXIMIZES PRODUCTION

Cat equipment has built a solid reputation for service ease and low operating costs. The RM500B is no different: features such as ground level access to maintenance items, S.O.S.SM oil sampling ports, visual gauges or indicators and remote grease fittings help keep costs low and ensure that maintenance schedules are followed. New technology simplifies even more, as advanced system diagnostics and the LCD touchscreen can alert the operator to conditions that could affect production.

SIMPLE MAINTENANCE

- Visual indicators for fuel/water, hydraulic oil level, coolant level
- Ground level access to engine oil dipstick, engine oil filter
- LCD touchscreen provides air restriction indicator and alerts operator to performance issues
- Large doors and removable panels provide unrestricted access to critical components
- Reversing cooling fan ejects dust from cooling package to maintain optimum system performance
- Cat batteries require no maintenance
- Oil sampling and pressure testing ports reduce risk of spillage or contamination
- Grouped drain ports for simplified drainage and reduced spillage
- Optional Product Link can help you track and maintain your fleet
- Storage bin for bits keeps a steady supply on hand



Grouped Drain Valves



Grouped Remote Grease Fittings



Visual Indicator Gauges

ENHANCING CAPABILITY

OPTIONAL EQUIPMENT

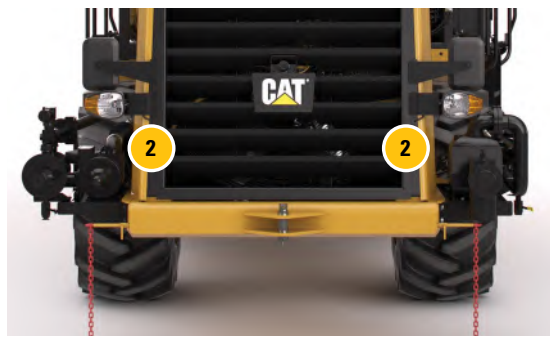

1 WATER SPRAY SYSTEM

Water Spray System automates the addition of metered water to the mixing chamber, allowing the machine to easily mix the proper measured amount to the materials. It provides an infinitely variable volume capacity of 114 to 1136 liters (30 to 300 gallons) per minute with two nozzles that provide a high flow range and a low flow range.

For water use only—not for use with emulsions.

1 ULTRA LOW-FLOW WATER SPRAY SYSTEM

Water Spray System automates the addition of metered water to the mixing chamber, allowing the machine to easily mix the proper measured amount to the materials. It provides an infinitely variable volume capacity of 60 to 600 liters (16 to 160 gallons) per minute with two nozzles that provide a high flow range and a low flow range.

For water use only—not for use with emulsions.

2 WATER SPRAY AND EMULSION SPRAY SYSTEM

Both Water Spray System and Emulsion Spray Systems installed to allow simultaneous or individual system operation.

3 EMULSION SPRAY SYSTEM

Emulsion Spray System automates the addition of metered emulsion to the mixing chamber, allowing the machine to easily mix the proper measured amount to the materials. This pump unit provides an infinitely variable volume capacity of 114 to 946 liters (30 to 250 gallons) per minute. Three sets of nozzles on the spray bar ensure proper fan pattern.

4 TORQUE LIMITER

The torque limiter minimizes the amount of torque that can be transferred to the engine. This allows the mechanism to limit potential damage when the rotor strikes an immovable object like a manhole cover.

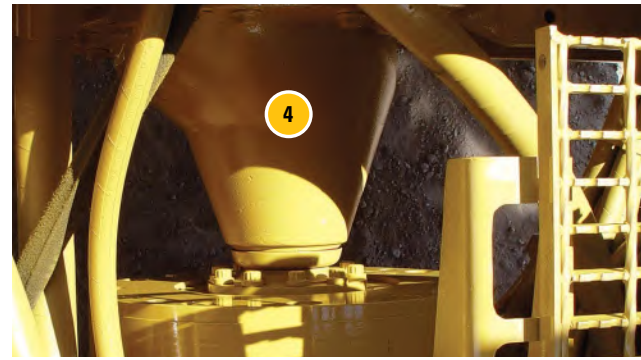

5 WARNING BEACON

Amber strobe beacon required on many job sites. Mounted on retractable pole.

Requires Working Lights package.



6 BOLT-ON COUNTERWEIGHT

Bolt-on 1600 kg (3,500 lb) counterweight kit enhances machine performance in tough reclamation applications. Recommended for asphalt cuts 25 cm (10 in) deep or greater.

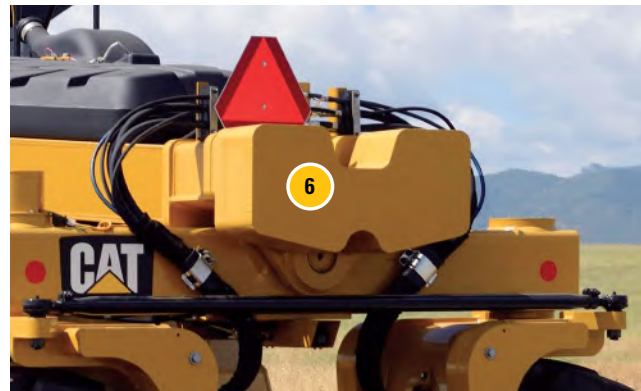

7 FOPS

Falling Object Protective Structure provides Level 1 protection. Bolts on to ROPS structure and also serves as a sun canopy. Requires ROPS.

8 ROPS

Two-post Roll Over Protective Structure bolts directly onto flanges welded behind operator's platform.





9 MIRROR PACKAGE

Required in many countries. Mirror package enhances visibility to front tires and front of the machine, as well as along the sides. Includes 8 adjustable mirrors.

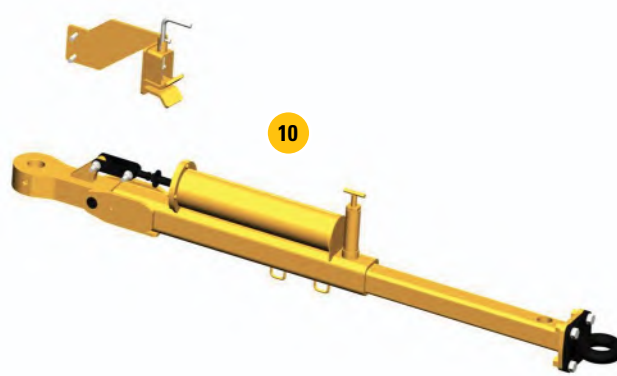

10 PUSH BAR

Deploys telescopically to provide a firm connection to water or emulsion truck. Folds to storage position against front bumper.

ROTOR DOOR REMOTE CAMERA

Provides operator with remote view to rear chamber door, allowing easy monitoring of machine operation and material sizing.



12 PRODUCT LINK™

Product Link gathers and wirelessly transmits key machine data via cellular and satellite communications from the machine to Equipment Manager which can be accessed remotely through a secure web based application hosted on the dealer website.

Subscription required. Speak to your Cat dealer for details.

13 ROADING LIGHTS

Roading Lights package enables on-highway transportation. Package includes 2 front-facing headlights, side amber turn signal/hazard lamps (2 front, 2 rear), and a slow moving vehicle sign.

14 COMMISSIONING SUPPORT

Certified Caterpillar trainers cover proper machine setup, basic maintenance, operation and application. Training lasts approximately 3 days and is conducted at the customer's location or jobsite.

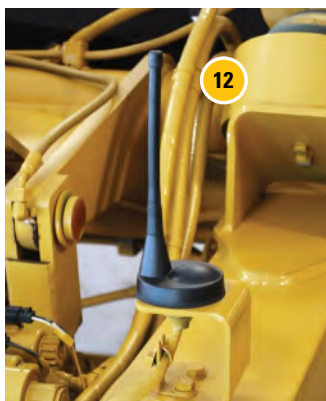

ARMOR AGAINST ABRASION AND FRICTION

WEAR PARTS

BREAKER BAR

Steel assembly mounts inside of rotor chamber. For use with Universal 16" and Universal 18" rotors. Provides more control over material sizing by keeping material in the chamber longer and acting as a crushing agent against which larger chunks of material can be broken down.

Part Number: 193-1039 (Order Quantity: 3)

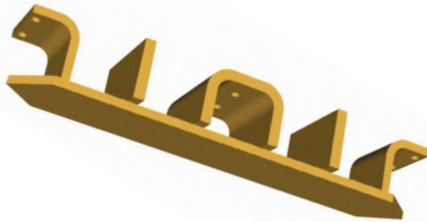

WEAR DISC

Disc installs inside rotor chamber on each side of rotor drum to provide protection and guide the depth adjustment of the rotor chain drive while keeping material inside chamber.

Part Number: 231-4209 (Order Quantity: 2)

CHAMBER GROUP (WEAR SKIS)

Steel skis mount to bottom of rotor chamber. Provides protection from ground friction on main chamber housing.

Part Numbers:

Center Plate 140-1188 (Order Quantity: 2)

Front and Back Plate 140-1187 (Order Quantity: 4)

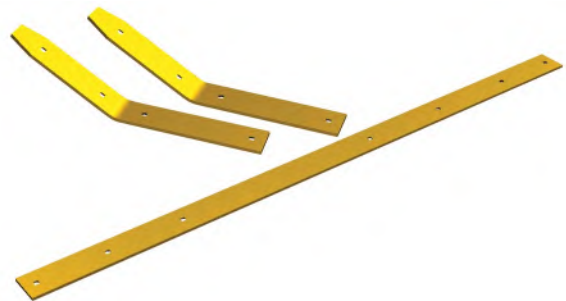

REAR DOOR STRIKE OFF

Strike off installs on rear chamber door. Provides protection for rear door from friction caused by dragging in material. Reversible design extends use.

Part Number: 077-7730 (Order Quantity: 1)

RM500B ROTARY MIXER SPECIFICATIONS

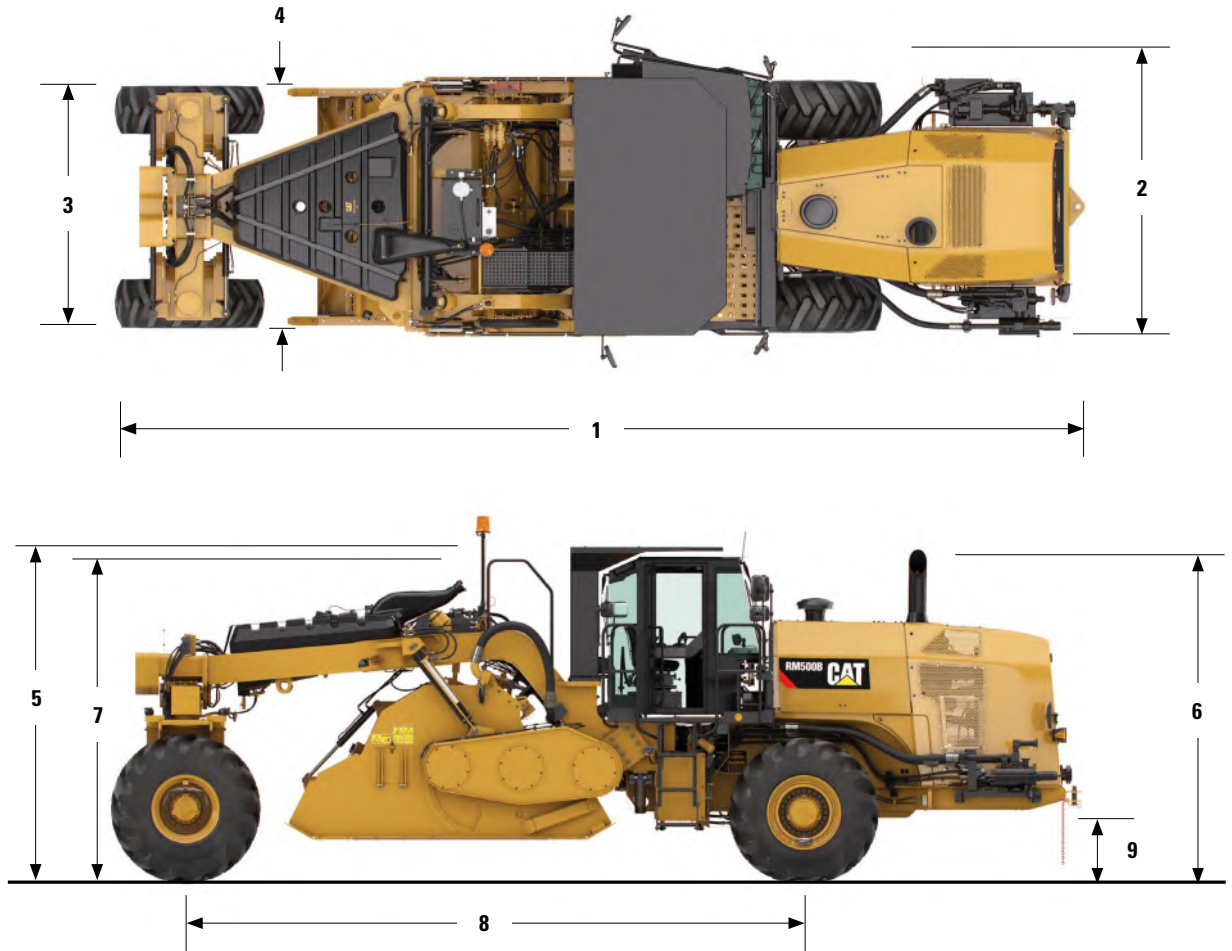

RM500B ROTARY MIXER SPECIFICATIONS

RM500B

EUROPE, CANADA, US ONLY

Weights

Operating Weight w/ ROPS cab		
w/ Universal Rotor 16"	28 400 kg	62,611 lb
w/ Universal Rotor 18" (EU only)	28 770 kg	63,427 lb
w/ Combination Rotor	27 439 kg	60,493 lb
w/ Soil Rotor	28 261 kg	62,283 lb

Engine - Powertrain

Engine Model	Cat C15 ACERT	
Global Emissions	Tier 4 Final/Stage IV	
Gross Power - SAE J1995	407 kW	546 hp
Net Power - ISO 14396	402 kW	539 hp
Displacement	15.1 L	923 in ³
Stroke	171 mm	6.7 in
Bore	137 mm	5.4 in
Max. Travel Speed (Forward or Reverse)	10 km/h	6.2 mph

Dimensions

1 Overall Length	10.32 m	33.83 ft
2 Overall Width	2.98 m	9.58 ft
3 Width at Rear Wheels	2.82 m	9.17 ft
4 Rotor Hood Width	2.53 m	8.25 ft
5 Height at ROPS	3.59 m	11.78 ft

Service Refill Capacities

Fuel Tank, total capacity	1056 L	279 gal
DEF Tank (EU, Canada and US only)	46 L	12.2 gal
Cooling System	70 L	18.5 gal
Engine Oil w/ Filter	52 L	15.7 gal
Propel Planetary Gear Reducer (ea.)		
Front	5 L	1.3 gal
Rear	4 L	1 gal
Hydraulic Tank (service refill)	224 L	59.2 gal
Rotor Drive Axle	17 L	4.5 gal
Rotor Bearing Reservoir	12 L	3.2 gal
Chain Case (ea.)	25.6 L	6.8 gal
Rotor Drive Planetary Gear Reducer (ea.)	3.8 L	1 gal
Rotor Transmission	12.4 L	3.25 gal

RM500B

ALL OTHER MARKETS

Weights

Operating Weight w/ ROPS cab		
w/ Universal Rotor 16"	27 970 kg	61,663 lb
w/ Combination Rotor	27 009 kg	59,545 lb
w/ Soil Rotor	27 831 kg	61,357 lb

Engine - Powertrain

Engine Model	Cat C15 ACERT	
Global Emissions	Tier 3/Stage IIIA	
Gross Power - SAE J1995	403 kW	540 hp
Net Power - ISO 14396	398 kW	534 hp
Displacement	15.1 L	923 in ³
Stroke	171 mm	6.7 in
Bore	137 mm	5.4 in
Max. Travel Speed (Forward or Reverse)	10 km/h	6.2 mph

6 Height at Cab	3.50 m	11.48 ft
7 Height at Handrail	3.47 m	11.38 ft
8 Wheelbase	6.55 m	21.33 ft
9 Ground Clearance	506 mm	19.9 in
Inside Turning Radius	4.33 m	14.2 ft

Miscellaneous

Electrical System	24 volts
Tires	
Front	725-70/25 L-4
Rear	23.1-26 LS-2

Rotor Drive Specifications

Rotor Speeds @ 2000 engine rpm	
First	110 rpm
Second	152 rpm
Third	205 rpm

The air conditioning system on this machine contains the fluorinated greenhouse gas refrigerant R134a (Global Warming Potential = 1430). The system contains 1.9 kg of refrigerant which has a CO₂ equivalent 2.717 metric tonne.



THE CAT PROMISE

PERFORMANCE. RELIABILITY. VALUE.

Cat RM500B Rotary Mixers deliver outstanding performance in a wide range of applications. High productivity, coupled with legendary Cat reliability, provides our customers with extraordinary value.

BUILT FOR IT.

©2017 Caterpillar | All Rights Reserved | QEHO1840-02 (02/17)
CAT, CATERPILLAR, BUILT FOR IT, their respective logos, "Caterpillar Yellow," the "Power Edge" trade dress as well as corporate and product identity used herein, are trademarks of Caterpillar and may not be used without permission.





The INGAA Foundation, Inc.

Planning Guidelines for Pipeline Construction During Frozen Conditions

**Prepared for The INGAA Foundation, Inc.
By: Natural Resource Group, LLC
December 2013**

**INGAA Foundation Final
Report No. 2013.04**





The INGAA Foundation, Inc.



PLANNING GUIDELINES FOR PIPELINE CONSTRUCTION DURING FROZEN CONDITIONS

TABLE OF CONTENTS

1.0	INTRODUCTION.....	1
2.0	PRECONSTRUCTION PLANNING.....	5
3.0	SNOW REMOVAL AND STORAGE	8
4.0	CROSSING WETLANDS AND WATERBODIES	11
5.0	UPLAND AREAS – TOPSOIL SEGREGATION, STORAGE, AND RESTORATION....	17
6.0	WATER HANDLING (TRENCH DEWATERING AND HYDROSTATIC TESTING).....	19
7.0	TEMPORARY EROSION AND SEDIMENT CONTROL MEASURES	22
8.0	FINAL STABILIZATION AND POST-CONSTRUCTION MONITORING	24
9.0	CONCLUSION	26

ATTACHMENT

Attachment A Frozen Construction Planning Guidelines Checklist

1.0 INTRODUCTION

PURPOSE

The INGAA Foundation has developed recommended guidelines that address winter season construction techniques under frozen conditions. The intent of these recommended guidelines is not to dictate one set of construction techniques for every project, but to provide an array of acceptable and proven techniques from which each Company can develop its own project-specific frozen conditions plan. The guidelines presented in this paper draw from the experience and leading best practices of the INGAA Foundation membership, interviews with industry practitioners (e.g., contractors, environmental inspectors, regulators), and reviews of construction plans for projects built under frozen conditions.

BACKGROUND



Pipeline Construction in Frozen Conditions

In a March 2013 report on United States natural gas pipeline capacity, the U.S. Energy Information Administration (EIA) noted that “more than half of new pipeline projects that entered commercial service in 2012 were in the Northeast.”¹ Elsewhere on the EIA’s website, data show that the number of producing gas wells in the United States has increased by 36 percent from 2001 to 2011.² This number includes an increase in producing gas wells of 36 percent in Pennsylvania and Colorado and 152 percent in North Dakota over the same

period. These numbers show an increase both in gas production and gas transportation activity in states that are prone to frozen conditions and frozen precipitation during the winter months.

Meanwhile, on May 31, 2013, the Federal Energy Regulatory Commission (FERC) issued a Notice of Availability³ of Final Revisions to the Upland Erosion Control, Revegetation, and Maintenance Plan (Plan) and the Wetland and Waterbody Construction and Mitigation Procedures (Procedures). Included in the revisions are a new section on winter construction and the FERC’s specific recommendations for the content of Winter Construction Plans, when

¹ EIA Report, “Over half of United States natural gas pipeline projects in 2012 were in the Northeast,” March 25, 2013. Accessed on August 17, 2013, at: <http://www.eia.gov/todayinenergy/detail.cfm?id=10511>.

² EIA Data. Accessed August 16, 2013, at: http://www.eia.gov/dnav/ng/ng_prod_wells_s1_a.htm.

³ FERC Docket No. AD12-2-000, May 31, 2013. Accessed on August 17, 2013, at: <http://www.ferc.gov/industries/gas/enviro/guidelines.asp>.

indicated for a given project. The FERC's recommendations recognize the increasing incidence of natural gas pipeline construction during winter months and under frozen conditions, especially in the northern, northeastern, and Rocky Mountain regions.



Pipeline Construction in Frozen Conditions

The INGAA Foundation recognizes that additional pipeline infrastructure will be constructed to service developing energy resource areas in the northern United States. Furthermore, owing to a variety of factors (e.g., certain restrictions for threatened and endangered species, migratory bird issues, aggressive service schedules, and the geographic concentration of construction activities), much of this construction is likely to occur during the winter months or under frozen conditions. While the FERC does not encourage or require winter construction, other federal agencies may recommend avoidance timeframes requiring interstate natural gas pipeline companies (Company/Companies) to construct in frozen conditions for the purpose of minimizing impacts to the environment. However, winter

conditions such as snow fall, frozen soil, and sub-freezing ambient air temperatures have the potential to impact pipeline construction activities. Good planning can help avoid, reduce, or minimize those impacts.

To that end, the INGAA Foundation has chosen to use certain terminology based on broad standards of use and acceptance in the pipeline construction field, rather than adopting regulatory terms of art. In this document, the INGAA Foundation has chosen to use the phrase "frozen conditions" as opposed to "winter conditions" based on the fact that winter conditions vary throughout the United States, and that the majority of construction issues under non-frozen conditions, whatever the season, are already addressed in the FERC's Plan⁴ and Procedures⁵. The INGAA Foundation recognizes that the FERC's new guidance regarding Winter Construction Plans broadly refers to "winter weather conditions"⁶ and "winter construction procedures (e.g., snow handling and removal, access road construction and maintenance, soil handling under saturated or frozen conditions, topsoil stripping)."⁷ However, for the purposes of these guidelines, the term "frozen conditions" is used as the basis of the following discussion and assumes the presence of frozen soil or frozen precipitation and the unique construction

⁴ FERC Upland Erosion Control, Revegetation, and Maintenance Plan, May 2013 Version. Accessed on August 9, 2013, at: <http://www.ferc.gov/industries/gas/enviro/Plan.pdf>.

⁵ FERC Wetland and Waterbody Construction and Mitigation Procedures, May 2013 Version. Accessed on August 9, 2013, at: <http://www.ferc.gov/industries/gas/enviro/procedures.pdf>.

⁶ Id at p. 6.

⁷ Id.

techniques and other measures used under such conditions. In addition, these guidelines apply generally to winter construction in northern states, as well as other states that experience frozen conditions for shorter periods of time (e.g., the Rocky Mountain states).

Recently, a number of interstate pipeline projects (i.e., El Paso Corporation's Ruby Pipeline, Dominion's Appalachian Lateral, Alliance Pipeline's Tioga Lateral, and Tennessee Gas Pipeline Company's 300 Line) have either planned for or unexpectedly found themselves performing pipeline construction activities under frozen conditions due to permit requirements or construction delays. The recent increase in overall construction activity could result in more projects scheduling construction during frozen conditions as Companies seek to avoid biological timing restrictions (e.g., migratory bird nesting and fish spawning seasons) and to minimize competition for labor, materials, and equipment. The INGAA Foundation acknowledges that, while construction under frozen conditions can minimize selected impacts, it can also result in other impacts and challenges that are not faced during the warmer months.

After identifying the need for industry guidance regarding construction under frozen conditions, the INGAA Foundation convened a steering committee comprised of INGAA staff and INGAA member organizations representing energy companies and construction contractors. The INGAA Foundation wishes to thank the following members of the steering committee for their time and expertise:

Monica Howard	Energy Transfer Partners
John Cassady	TransCanada Corporation
Farrah Lowe	NiSource, Inc.
Tim Powell	Williams Companies
Terry Delasalle	Greene's Energy Group
Greg Bosch	Mears Group, Inc.
Lisa Beal	INGAA
Terry Boss	INGAA
Richard Hoffmann	The INGAA Foundation
Ron Miller	Basic Systems, Inc.

The INGAA Foundation contracted with Natural Resource Group, LLC (NRG) to prepare the guidance document. The steering committee and NRG participated in regular conference calls to identify the direction and format of the resulting document. NRG conducted a review of existing Winter Construction Plans prepared for pipeline projects in various locations across North America. The plans included those that are publically available as part of projects that are regulated by a government agency, such as the FERC, and plans submitted to the steering committee from the INGAA membership. NRG conducted interviews with representatives from energy companies, pipeline contractors, environmental inspectors, and federal and state regulatory agency personnel to identify issues and best management practices (BMPs) associated with pipeline construction under frozen conditions. Following identification of the issues and BMPs, the INGAA Foundation sponsored a workshop held in Washington, DC. The purpose of the workshop was to reach a wider group of industry and agency representatives and solicit their input on the opportunities, challenges, and solutions for

The INGAA Foundation identified that, with the increase in pipeline construction in frozen conditions, the industry could benefit from having guidelines that address the unique challenges of construction under frozen conditions by pipeline designers, construction companies, operators, and regulators.

pipeline construction under frozen conditions. Thirty-seven people attended the workshop including 19 representatives from energy companies, 9 representatives from federal regulatory and land management agencies, 5 representatives from environmental and engineering service companies, 2 representatives from pipeline construction contractors, and 2 representatives from the INGAA Foundation. The information gathered during the research phase and from the workshop was compiled into this guidance document.

The guidelines presented herein focus on construction and environmental protection practices unique to frozen conditions. These guidelines primarily focus on providing additional information to Companies regarding what to consider when developing a project-specific frozen conditions plan and what past practices have been successful under frozen conditions. In this way, the guidance presented in this document may also be used by Companies to develop project-specific plans based on each project's unique location, timing, and other variables.



Snow Removal From Trench

This paper is structured to first present a general discussion of the issues (i.e., preconstruction planning, snow removal and storage, crossing of wetlands and waterbodies, upland topsoil segregation, excavation and backfilling, water handling, temporary erosion control measures, and site stabilization and monitoring) to be considered when developing a project-specific frozen conditions plan. Following the general

discussion of issues, specific elements are presented that a Company can consider adopting when developing a project-specific frozen conditions plan. Each project will vary in the level of detail and considerations necessary for each due to the topography, location, climate, and other variables that can impact construction techniques. Finally, to assist a Company in the planning process, Attachment A contains a checklist that could be used in developing a reasonable and comprehensive frozen conditions plan.

2.0 PRECONSTRUCTION PLANNING

Due to increasing regulatory scrutiny of pipeline construction completed during frozen conditions and the rising likelihood that pipeline construction may occur during frozen conditions, it is important that Companies plan early for such conditions on their own projects. Project procurement personnel need to plan for the acquisition of materials to be used during frozen conditions, and construction crews need to understand their responsibilities in implementing special measures for frozen conditions, and when such measures should be used. In addition, project planners also need to be realistic about the slower pace of construction during frozen conditions in determining overall project schedule.

PRECONSTRUCTION ELEMENTS TO CONSIDER IN DEVELOPING A FROZEN CONDITIONS PLAN

Defining Frozen Condition: A company should consult with the project's primary regulatory agencies in order to fully understand how "frozen conditions" will be defined in each agency's permits. Once the broadest definition of frozen conditions has been established, the next step is to incorporate a clear definition of frozen conditions into the project's early planning documents. By engaging the agencies early in the process and incorporating clear definitions into the project's construction plans and schedule, Companies will avoid delays in project completion and potentially permit violations.

Project Schedule and Timing: A Company should take into account the project schedule, as well as the potential for significant schedule changes, and incorporate project flexibility into its plans to avoid unanticipated frozen conditions during construction. Construction contractors can be involved early in the development of the frozen conditions plan as they are a knowledgeable source of information.

When developing a project-specific frozen conditions plan, it is important to define the conditions or timing under which the plan would be implemented. Some Companies set specific calendar dates as to when the frozen conditions plan will be implemented while other Companies prefer to set ambient air or soil temperatures, depth of soil freezing, or moisture content of soil as the threshold for when to implement the plan.

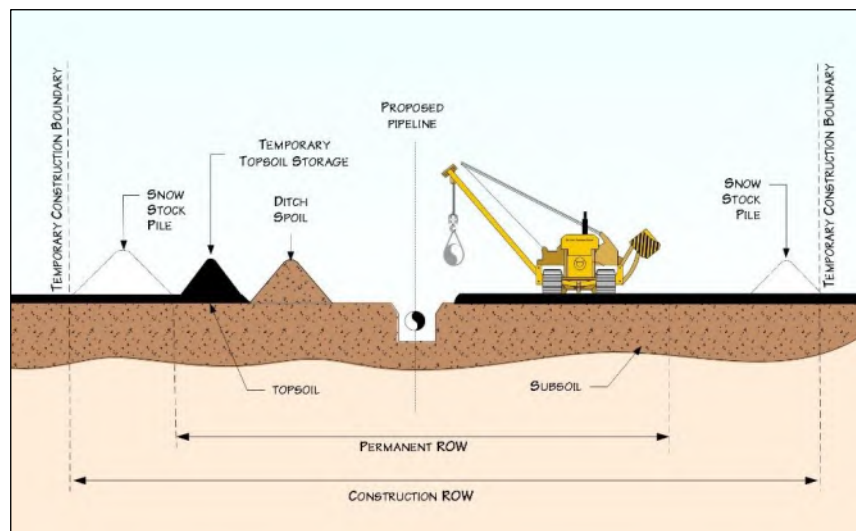

Typical Construction Right-of-Way in Frozen Conditions

Companies who advocate that a set time period is the most effective method note that it ensures that erosion control devices will be installed prior to soils becoming frozen and using materials and procedures that are able to withstand frozen conditions and runoff from snow melt.

In addition to or in the absence of direct guidance from a project's primary regulatory agencies, the INGAA Foundation recommends that Companies consider developing and implementing a frozen conditions plan when any of the following conditions could occur in the project area:

- sustained cold temperatures occur that result in the soil freezing to a depth of 1 to 2 inches or more;
- backfill material could freeze to the extent that adequate compaction becomes difficult;
- topsoil stockpiles could freeze and cannot be uniformly redistributed across disturbed areas or separated from the sub-grade material;
- snow accumulations are great enough to prevent visual observation of the construction work area; or
- historical conditions in the region indicate that significant runoff from spring snow melt may require additional measures.

Communication: As with all plans implemented on a construction project, constant communication among Company representatives and contractors, and in some cases the regulators, will ensure the greatest success for construction, operation, and restoration of a project area. Each plan should identify the chain of decision making that will occur on a day-to-day basis for determining the construction practices that can occur in any one area.

A decision-making chain is necessary for determining if work on the construction right-of-way should occur in frozen weather conditions due to changing conditions.



Shaker Equipment Backfilling Trench

For example, in regions where there is shallow freezing that occurs in the morning and evening followed by a daytime thaw, different activities may be approved or restricted by a project manager or construction supervisor, depending on the time of day. An agreed upon process in the pre-planning phase will assist in the project's successful completion.

3.0 SNOW REMOVAL AND STORAGE

Significant snow fall events before or during construction can create unsafe work conditions and make it difficult to complete the job properly. Removal of snow from the construction workspace may be necessary to provide safe and efficient working conditions and to expose soils for grading and excavation. Snow may also need to be removed along access roads to allow safe access to the right-of-way.



Snow Covered Right-of-Way

Snow may be used for beneficial uses, such as insulation over the trenchline prior to excavation, if practical, or to reduce frost penetration along the trenchline (see Section 6.0, Excavation and Backfilling). Snow can also be used to build frost roads through wetlands and other saturated or otherwise unstable areas (see Section 4.0, Crossing Wetlands and Waterbodies).

SNOW REMOVAL ELEMENTS TO CONSIDER IN DEVELOPING A FROZEN CONDITIONS PLAN



Preparing the Right-of-Way

Advance Planning with the Landowner:

Prior to construction, land agents should address snow removal and storage with landowners. Items to discuss with landowners include snow removal equipment, snow storage areas, and existing features (gates, fences, etc.). In the pre-planning phase, it is recommended that land agents identify and gain landowner approval for extra area off the approved right-of-way and along access roads to allow snow storage. Previous projects in northern climates have used additional

workspace areas as well as off-right-of-way yards for snow storage. Such areas should occur regularly along the right-of-way and be sized accordingly to handle at least the area's average snowfall amounts for the given time period.

The installation of temporary gates at livestock fence crossings should occur prior to or concurrent with snow removal activities and in accordance with landowner requirements to allow vehicle access through these areas for snow removal activities, while maintaining the function of livestock enclosures.

Snow Removal Equipment: The frozen conditions plan should identify the equipment acceptable for snow removal. Snow is typically bladed or pushed off the access roads and right-of-way with a motor-grader, snowplow, or bulldozer and then stockpiled along the outer portions of the construction right-of-way or extra workspace areas. Note that the FERC requires that stockpiles remain within approved workspaces, which may result in the need for additional workspaces specifically for snow storage. There is the expectation that the workspaces for snow storage would not be cleared or graded; however, they should have survey clearances and approvals for use as vegetation or ground disturbance could occur.

Snow removal activities should be monitored by the Environmental Inspector.



Equipment Modified With a Shoe

Snow could also be blown off the right-of-way using industrial blowers. The blown snow should be spread evenly to minimize damage to woody vegetation or other resources off the right-of-way.

An environmental inspector should be present to monitor snow removal activities. If not monitored, snow removal equipment can inadvertently scrape off or blow away underlying soil and vegetation. Contractors have identified that bladed equipment on the motor-grader, snowplow, or bulldozer could be fitted with a "shoe" to minimize impacts on the underlying soil and vegetation. Snow blowers can also be calibrated to avoid removal of topsoil beneath the snow.

The plan should specify if equipment modifications (e.g., installation of shoes) will be used to prevent topsoil or vegetation removal. The FERC will allow snow to go beyond the approved workspaces, if the material is being blown or lifted in buckets in a manner that avoids entrainment of soil and vegetation.

Signage: The frozen conditions plan should address the type, location, and placing of proper signage for designated avoidance areas, such as cultural resource sites or protected species habitat areas located adjacent to the construction workspace, to prevent inadvertent damage during snow removal activities. Consider the need for high visibility signage in areas where winter recreation activities (e.g. snowmobiling) and low contrast visibility could create safety hazards. Frozen ground conditions should be anticipated and signs placed in advance.

Snow Storage: The plan for snow storage within the right-of-way should clearly separate snow from spoil storage to avoid mixing. Consider the placement of stockpiled snow to ensure that snow melt will not cause erosion and sediment loss. The plan should consider specifying placement of gaps in stockpiled snow piles based on an assessment of drainage patterns to allow water to drain off the right-of-way during spring thaw and to allow for landowner and wildlife access across the right-of-way. Such measures can also be incorporated into the project's Stormwater Pollution Prevention Plan (SWPPP) in order to account for the best locations for snow stockpiles and gaps in relation to suitable erosion control materials prior to the onset of frozen conditions. Access roads can act as a conduit for the concentrated flow of melt water with the potential to create safety hazards or result in impacts on sensitive resources. Erosion control devices and diversion berms should be installed within the construction right-of-way and along access roads in accordance with the project's SWPPP or other applicable plans.

Erosion control devices should be installed on access roads that can provide a conduit for the concentrated flow of melt water.

4.0 CROSSING WETLANDS AND WATERBODIES

Construction through wetlands and other wet areas presents its own unique challenges, such as wheel rutting and mixing of soils, impacts to plants and other species, and downtime from construction equipment becoming stuck in loose or saturated soils. The following elements contribute to the challenges inherent in crossing and restoring wetlands and waterbodies and are addressed in this section: soil types, extent of freezing, topsoil segregation requirements, open ditch limitations, and trench subsidence and crowning.



Segregating Frozen Topsoil Layer in Wetland

WETLANDS AND WATERBODIES – ELEMENTS TO CONSIDER IN DEVELOPING A FROZEN CONDITIONS PLAN

Frost/Ice Roads: The linear nature of pipelines can make it impractical to avoid all difficult construction areas such as large, shallow standing water wetlands, peat bogs, tamarack or black spruce swamps, and saturated or otherwise unstable soils. Construction across these types of features can be accomplished during frozen conditions using frost or ice roads to provide additional equipment support. In addition, frozen conditions can also make environmentally sensitive areas less susceptible to damage.

Equipment Bridges: Equipment bridge installation and removal should be considered during the project planning stage, taking into account high water levels during the spring melt. There are two options for frozen conditions, either to remove the bridge prior to the onset of frozen conditions or to plan to install the bridge to a height that will not impede spring run-off. Because many agencies have restrictions on leaving equipment bridges in place through the frozen months, a review of the project permits should be conducted prior to finalizing the plan.

Soils: The type of wetland soils encountered can affect the feasibility of construction during frozen conditions. For example, wetlands with deep organic soils can generate heat through natural decomposition, making it difficult to freeze the soils unless long periods of sub-zero temperatures occur and proper frost road techniques are implemented. Conversely, deep frost in wetlands with a shallow organic layer over mineral soils can result in the upper organic layer being frozen to the subsoil, making topsoil segregation difficult.

Preconstruction planning, which could include soil borings prior to construction, will provide information to evaluate site-specific soil conditions expected during construction. Appropriate alternative techniques could be identified for use at the time of construction to limit the potential for soil mixing.

Topsoil Segregation: Prior to trench excavation, snow can be piled over the trenchline to form an insulating barrier and prevent deep frost penetration. The stockpiled snow is then removed just prior to excavation to prevent mixing of the snow with the topsoil material. It should be noted that projects have encountered trench wall stability issues using this technique, especially where there are unconsolidated soils beneath the frost layer. Careful planning and implementation should be followed to reduce the risk of trench wall instability.



Ditching Machine

Projects have also incorporated the use of specialty equipment to excavate the ditch where a deep frost layer has formed. Special equipment such as rock saws have been used to cut through the frost layer on either side of the ditch line. The frozen block of material is then removed from the ditch line and segregated from all other excavated materials, similar to standard topsoil segregation techniques used in upland construction. This frozen block of soil

contains the topsoil to be restored during backfilling. Other techniques that have been used during frozen conditions include rotary wheel trenchers equipped with rock buckets to segregate the top 1 foot of topsoil into a pile, followed by a second pass to excavate the subsoil. Once the frozen layer is removed, trenching may also be completed using conventional removal with excavators.

Open Trench or Ditch: The longer time that excavated materials from the trench are exposed to freezing ambient air temperatures, the more difficult it can become to properly backfill the trench with these materials. Where significant freezing of the spoil material has occurred, the backfill material will tend to be larger, angular blocks. If not broken into smaller pieces prior to backfill, these large blocks can create significant voids in the backfill, causing trench subsidence following spring thaw. This may give the perception that there is significant excess spoil material left after trench backfill is completed.

Large, angular frozen backfill material can cause subsidence of the trench following thaw due to air cavities in the backfill.

Rather than removing the “excess” material, a slight crown could be created over the trench line. As the backfill material thaws in the spring and summer, the large frozen soil clumps begin to break apart and collapse into void spaces, resulting in subsidence of the material, ranging from a couple of inches to greater than a foot in depth. There is potential that the original crown may not completely recede to the surrounding contour, requiring additional grading. However, this is preferable to removal of the “excess” material resulting in a lack of enough native material available to correct the subsidence.

Another issue that has occurred during construction in frozen conditions is that wetland spoil material with high water content (e.g., non-cohesive soils) can freeze to the ground surface in its storage location. This can result in difficulties retrieving the material for backfill as well as restoring the area to proper grade and elevation.

Minimizing the amount of open trench during frozen conditions reduces the risk of freezing excavated spoil materials. Projects have limited the pace of excavation activities to the length of ditch that can be excavated, the pipe lowered in, and fully backfilled within a specified period of time (ranging from 24 to 72 hours). Projects have also stripped off outer layers of a frozen spoil pile to use unfrozen inner subsoil first during backfilling. Remaining frozen subsoil is broken into smaller pieces prior to backfilling to reduce the size of voids in the backfilled trench. Consider the use of specialized equipment to break up frozen backfill material to minimize future subsidence. Shaker hoes, rippers, and padding equipment may be useful to break up frozen backfill material. The deeper portions of the trench backfill material may be less frozen and more suitable to return to the trench first. The frozen backfill material should be set aside and placed on top of the backfilled trench or the trench backfilled with a crown.

Crowning to Mitigate Trench Subsidence: Crowning material over the trench or ditch line may be a suitable practice where trench subsidence is anticipated. The amount of crown needed to compensate for subsidence is difficult to estimate. Leaving a crown of insufficient volume will not fully account for subsidence and potentially alter wetland hydrology and vegetation growth by creating low spots. Leaving a crown that is too large can affect hydrology and surface drainage by forming a linear berm. In extreme cases, a crown that persists may result in establishment of upland vegetation within the wetland.

The crown should only be constructed directly over the backfilled trench with native material and should not extend out beyond the trenchline. Subsoil used to build the crown should not extend above natural surface grade. A crown should always be capped with native topsoil material to ensure elevations will be restored with topsoil at the surface. If the topsoil layer has been removed



Reducing Frozen Crown Over Backfilled Trench

as a block of frozen material, the blocks should be placed on top of the trench line as part of the crown and be pieced together to the extent practicable to prevent large gaps following thawing of the material. Small gaps should be left in the crown to allow for natural surface drainage before the material is fully settled during spring and summer thaw.

Monitor the trench for subsidence or excessive crowning as weather conditions improve.

Maintaining good records of conditions encountered during backfilling will help develop expectations of post-construction restoration requirements. Where the trench has been backfilled with frozen material, the company should monitor for subsidence and excessive crowning conditions. Probing of the backfilled material may be necessary to determine if frozen spoil persists prior to conducting crown remediation. Some projects have attempted to remediate what appears to be an excess crown before the backfilled material was completely thawed, resulting in a subsided trenchline after remediation.

Final restoration of wetlands should be completed to the maximum extent practicable during frozen conditions as access to complete additional remediation following spring melt may be limited. Where additional remediation is required to address excess crown or subsidence, proper topsoil segregation would be necessary. Completing this remediation work during non-frozen conditions may require specialty equipment, such as floatation (swamp) hoes. All techniques discussed in this section, including backfilling with frozen trench spoils, crowning to mitigate trench subsidence, and remediation of trench subsidence or excessive crowning, should be discussed with the appropriate regulating agencies prior to execution and incorporated into the project-specific frozen conditions plan when possible.

4.1 DEVELOPING FROST ROADS THROUGH WETLANDS

Frost or ice roads are used across wetlands where soil conditions may not be capable of supporting the weight of construction equipment during non-frozen periods. Frost roads can withstand greater vehicle loads as the formation of ice in the ground increases soil strength. Use of frost roads can be a less expensive alternative to other equipment supports such as timber mats. However, development of frost roads require sustained freezing weather conditions that allow for construction of the road as well as construction of the pipeline.

FROST ROADS THROUGH WETLANDS ELEMENTS TO CONSIDER IN DEVELOPING A FROZEN CONDITIONS PLAN

Plan Road Development: A plan should consider development of frost or ice roads after careful review of wetland resources along the route and in consultation with the jurisdictional permitting agency. Frost roads should be considered where conventional construction techniques are not feasible such as across large, deep, and/or saturated wetlands. If possible, the construction contractor should be involved in this process to define the project cost and schedule implications of creating

In general, frost roads are prescribed as a construction technique when wetland areas are so large, so deep, or so saturated (or all of the above) that conventional construction techniques are not feasible.

frost roads.

Right-of-Way Clearing: The amount of clearing needed prior to development of frost roads is dependent on the type of wetland crossed. In general, wetlands with saturated soils and/or standing water support fewer woody plant species, thus requiring less clearing activities. Wetland types such as tamarack bogs, cedar swamps, and scrub-shrub wetlands may require additional woody vegetation clearing. Temporary equipment mats or the use of low ground pressure equipment may be necessary to prevent rutting during the removal of trees and woody vegetation. Depending on project-specific conditions, clearing may be conducted prior to the onset of freezing conditions.

Construction of Temporary Frost Road: Development of frost roads should begin as soon as freezing conditions are sustained and there is sufficient frost or snow to support lightweight or low ground pressure equipment. Small equipment, such as wide-track snowmobiles, can be used to begin packing snow along the designated haul route, which reduces its insulating properties. Snow and herbaceous vegetation can act as an insulating blanket, preventing or slowing frost development.

Typically, a minimum of 30 inches of frost is needed to support the size of equipment necessary for installation of a 36-inch-diameter pipeline.

As frost is driven deeper into the haul road, progressively larger and heavier equipment is brought in to continue to drive frost deeper into the subsurface material. This process squeezes soil moisture closer to the surface, where it is exposed to freezing temperatures. The depth or thickness of the frost road depends on the type of equipment that will utilize the road. For instance, the typical equipment required to construct a 36-inch-diameter pipeline, would generally require 30 inches of compacted frost.

Once the appropriate depth of frost is reached to support equipment associated with construction of the pipeline, efforts to maintain the frost road may be reduced, depending on site conditions and sustained freezing temperatures.

Water trucks may also be used to spray the frost road and build up the frozen layer. These activities are typically conducted around the clock to take advantage of the coldest hours of the day until such time as the frost road is determined to be suitable for pipeline construction. Note that soil temperatures can change even during cold weather months. A thawing of the frost road could result in limited access and a reduced ability to avoid impacts to sensitive resources, which may prompt the need to install construction mats.



Building the Ice Road

Once the frost road is established, it should be maintained by removing or compacting additional snowfalls to prevent development of an insulating cover as well as to maintain equipment travel. A layer of snow should be kept on the frost road to reflect the sun's energy and minimize thawing during warmer periods of the day. Darker areas of exposed soil can absorb heat and accelerate thawing, reducing the length of time the frost road can be safely used. Bare spots should be covered with snow as soon as possible.

5.0 UPLAND AREAS – TOPSOIL SEGREGATION, STORAGE, AND RESTORATION

Frozen soil conditions in upland (unsaturated, non-wetland) areas can create a firm working surface with a low potential for topsoil mixing. Planning to construct over frozen soils could be a factor in determining how large of an area over which to segregate topsoil. However, frozen conditions are not always consistent and intermittent thaws can occur depending on the location or annual variations in cool season temperatures. Construction or restoration work could extend into the spring thaw period due to unanticipated schedule slowdowns or an unseasonably early thaw period.



Topsoil Frozen to Subsoil

UPLAND AREAS – ELEMENTS TO CONSIDER IN DEVELOPING A FROZEN CONDITIONS PLAN

Be aware of seasonal road restrictions and load limits that may affect access to the right-of-way.

Construction Schedule: The average duration and intensity of frozen conditions in the project region should be considered early in project planning and scheduling. In areas with short periods of frozen conditions, minor workarounds to avoid managing frozen topsoil until adequately thawed is preferred. Regions with longer periods of freezing temperatures and deeper frost depths will require more deliberate planning for topsoil management and segregation. Consider that certain

state and local communities implement seasonal road restrictions and load limits that may affect the ability to move construction equipment and materials to the right-of-way. Long-term topsoil stockpiling to manage the topsoil and accomplish more effective seeding and restoration may be necessary after the spring thaw.

Topsoil Removal: Topsoil segregation should be completed prior to frozen soil conditions where practicable in areas with long periods of frozen conditions. When the topsoil is frozen at the time of topsoil stripping, multiple passes (vs. a single pass) with a bulldozer or other specialized equipment may be necessary to remove only the topsoil and not the subsoil. Specialized equipment (e.g., soil rippers) may be necessary to break up the topsoil prior to removal. An “Iron Wolf” or pavement grinder can remove frozen topsoil; however, the use of this method should be reserved for special situations and in cooperation with landowners and regulatory agencies because this process can affect the native soil structure.



Iron Wolf Breaking up Frozen Topsoil

During thaw periods, travel over topsoil can cause soil mixing resulting in work shutdowns, restrictions, or move-arounds.

Timing of Topsoil Restoration: The restoration of topsoil should ideally occur after both the stockpiled topsoil and the exposed subsoil have thawed, the ground has dried following the spring melt, and the soils are more easily worked. Proper timing of topsoil replacement can avoid the need to re-segregate topsoil from the trenchline should subsidence occur. During thaw periods, travel or use of equipment over topsoil may need to be suspended to avoid soil mixing. This could result in work shutdowns, work hour restrictions, move-arounds, or the use of construction timber mats. A longer wet period after the thaw could delay topsoil restoration, which would further delay permanent seeding and the establishment of vegetation. Such a wet period would increase the need for vigilance of erosion and sediment control measures to minimize the loss of topsoil and avoid discharges to wetlands and waterbodies.

The frozen conditions plan may need to include provisions for permanent seeding in the fall or following spring depending on the location, soil moisture conditions, and recommendations from land management agencies and the Natural Resources Conservation Service (NRCS). Right-of-way stabilization measures must be implemented regardless of whether topsoil restoration occurs under frozen conditions or is delayed. Some options for temporary stabilization of the right-of-way and segregated topsoil pile include mulching and dormant seeding.

6.0 WATER HANDLING (TRENCH DEWATERING AND HYDROSTATIC TESTING)

The management of water is an essential factor of pipeline construction. All new pipelines require the use of water to perform hydrostatic testing prior to placing the line into service. In addition, depending on such project-specific factors as geography, climate, and season, open trenches may fill with water from rain events or from the presence of groundwater. Water in the trench must often be removed (trench dewatering) to prevent the trench sidewalls from collapsing or otherwise to maintain trench or backfill integrity prior to or during pipe installation and restoration. All of these activities can become difficult at best, and dangerous at worst, during sustained frozen conditions.



Hydrostatic Test Water Discharge Structure

The Company should plan to identify the methods and materials necessary to address water handling specific to construction under frozen conditions.

Frozen conditions can disrupt hydrostatic testing in various ways. Pumps and other equipment like small-diameter pipes can freeze entirely in extreme cold. Water sources can become unavailable if frozen, and water discharges can be difficult to control if discharge areas are frozen, thereby slowing or preventing water from naturally seeping into the ground or, when allowed by permit, entering a surface waterbody.

Even during frozen conditions, groundwater can seep into an open trench, and rain water or melting snow can run into a trench from the surface, requiring dewatering prior to pipeline installation. Similar to standard summer construction, water in an open trench can prevent the trench from being inspected for obstructions and can affect the consistency of backfill material. During freezing conditions, ice can develop in the open trench. If the ice is not removed from the trench prior to backfill, the ice can create voids in the backfill material, which can result in significant backfill subsidence following spring melt. To address these issues, the company should plan and maintain sufficient means and devices with which to promptly remove and dispose of water entering the trench or other parts of the right-of-way or work area.

WATER HANDLING ELEMENTS TO CONSIDER IN DEVELOPING A FROZEN CONDITIONS PLAN



Trench With Frozen Infiltrated Groundwater

Equipment Care: Freezing conditions make operating equipment outdoors more difficult. Lubricants and other liquids in pumps can freeze up and not operate. Plans should consider measures to ensure equipment is protected from the elements and operational prior to use. When dewatering during freezing conditions, pumps may have to be installed in small, heated shelters to prevent the pumps from freezing and becoming non-operational or causing damage to the pumps that could result in a spill or leak of lubricants or fuel. The use of anti-freeze liquids in the pump housing is not recommended due to the difficulty of removing the potentially hazardous liquids prior to the re-use of the pumps.

When not in use, dewatering pumps and hoses should be properly drained during freezing conditions to prevent damage.

Discharge Rate and Volume: In areas where trench dewatering or test water discharges are occurring on top of frozen ground, the discharged water will not absorb into the ground, resulting in increased surface runoff and ponding in low lying areas. The increased runoff can melt and erode the upper layer of frozen soil, especially in areas where the water may become channelized. Discharged water can also flow underneath the snow, causing unobserved erosion and potentially, deposition in sensitive resource areas.

Similar to dewatering activities during standard non-frozen construction conditions, dewatering activities performed during frozen conditions should be continuously monitored and adjusted as necessary. Discharge locations should be carefully evaluated and selected based on site conditions including vegetation cover, soil type, and topography.

Structure Installation and Removal: Frozen conditions plans should consider installing dewatering structures (e.g., filter bags and straw bale structures) earlier in the construction process when ground conditions are favorable for installation. After periods of frozen ground conditions, installation of dewatering structures can prove to be challenging.

Removing dewatering structures promptly after final use will assist final clean-up of the project area. If not removed after use, these structures may freeze, preventing proper cleanup until spring. Locations of the filter bags placed off the right-of-way should be marked with lathe or similar methods to assist crews in relocating the filter bag for proper disposal.

Proper planning and communication with regulatory agencies with jurisdiction over water appropriation is important to successfully complete hydrostatic testing procedures.

Water Appropriation: Natural river flow levels are typically reduced in northern climate areas that have sustained temperatures at or below freezing for several months. These low-flow conditions can limit the rate and volume of water appropriation from natural water sources typically used for hydrostatically testing pipelines prior to placing the lines in service. If water is not available in the quantity or rate needed, alternate water appropriation sources may need to be located. Additionally, testing sections may need to be adjusted based on water availability and weather conditions.

Where testing will occur during low-flow periods, companies should discuss any appropriation volume or rate restrictions with the appropriate regulatory agencies.

7.0 TEMPORARY EROSION AND SEDIMENT CONTROL MEASURES

Temporary erosion and sediment control measures installed prior to or during frozen conditions may not remain functional under thaw conditions. This could be due to high flows of snowmelt during a quick warming period; the physical strains of intermittent freezing and thawing, including frost-heave; and the physical limitations of completing proper installation under frozen conditions.

Certain areas of the right-of-way may not be accessible during thawing periods or during the spring melt due to soft soil conditions, thus preventing regular inspections and hampering repairs or maintenance.



Erosion Control Devices With Protective Caps on Metal Stakes

TEMPORARY EROSION AND SEDIMENT CONTROL - ELEMENTS TO CONSIDER IN DEVELOPING A FROZEN CONDITIONS PLAN

Installation of Temporary Erosion and Sediment Controls: Companies should review the construction right-of-way in advance of frozen ground conditions and install the necessary temporary erosion and sediment control devices in advance of the changing weather. Advance placement will allow for the “keying” in of bales to the ground that will enable the devices to be more effective throughout construction. Consider the need to protect exposed soils from wind erosion. Frozen conditions may occur with little or no snow cover and exposed windrowed soils can be subject to drying winter winds leaving them susceptible to wind erosion.

Winter and Spring Thaw Inspection: In developing a project-specific frozen conditions plan, Companies should consider keeping an Environmental Inspector (EI) and environmental labor crew on site or on call through the periods of thaw to monitor erosion control structures and stabilization efforts and make adjustments or repairs as necessary and as right-of-way conditions allow. Stockpiles of materials should be suitably located within the project area to allow efficient repair and maintenance of erosion controls. Crews should have the proper equipment available to allow access to the right-of-way under soft soil conditions, such as all-terrain vehicles with oversized tires, to prevent rutting, topsoil mixing, and damage to other temporary erosion controls such as drivable berms.

Depending on the timing of the overall construction schedule and other limitations such as vehicle weight restrictions on public roads, the frozen conditions plan should address adequate crews to be available to conduct repairs or maintenance during thaw periods.

The project-specific frozen conditions plan should review language in stormwater permits and the FERC's Plan or the Company's own construction procedures regarding the frequency of erosion control inspections and the timeframes for repairs and maintenance. If the project is under FERC's jurisdiction, unique project conditions may indicate that modifications to the FERC Plan may be necessary to achieve compliance and avoid the need for variance requests during construction.

Monitoring Plan: If final cleanup and restoration activities have not occurred prior to the spring melt, monitoring of the right-of-way should be implemented during the delay between construction and restoration or temporary shutdown of construction activities. The monitoring program should identify: (1) erosion control structures requiring repair; (2) areas of slope instability; and (3) areas where significant levels of erosion are occurring. The EI should determine the most effective means of dealing with identified problems, taking into consideration the suitability of the right-of-way for access by equipment, potential damage that could



Right-of-Way Prepared for Final Stabilization

occur by equipment accessing the right-of-way, and the urgency/significance of the problem. Road restrictions and soft soils could limit access to the erosion controls requiring repair. Flyover inspections of areas that are inaccessible by wheeled vehicles or that are within or adjacent to a sensitive resource could be the most efficient method of conducting the inspection.

8.0 FINAL STABILIZATION AND POST-CONSTRUCTION MONITORING



Right-of-Way Stabilized for Winter

Whether restoration is completed under frozen conditions or delayed until the spring or summer period, the right-of-way will require stabilization prior to the spring thaw. Seed intended for site stabilization or restoration will not germinate under frozen conditions, and therefore Companies should plan for alternative methods of site stabilization prior to the first spring rains (see Section 7.0, Temporary Erosion and Sediment

Control). Some agencies do not recommend dormant seeding or mulching over snow based on limited effectiveness during snow melt and runoff and early spring rains.

FINAL STABILIZATION ELEMENTS TO CONSIDER IN DEVELOPING A FROZEN CONDITIONS PLAN

Timing of Restoration: Determine whether the project will be completely restored or if restoration will be delayed until after the spring thaw. Backfill all areas of open excavation or provide safety fencing and signage for protection. If restoration will be delayed, consider leaving the subsoil in a roughened condition to slow the sheet flow of water. After restoration, restore contours for drainage to preconstruction conditions. Delaying seeding can also result in the development of noxious weeds that require treatment, such as the application of herbicides, prior to additional seeding and other restoration activities.



Stabilization of the Right-of-Way

When restoration activities must be delayed, it is possible that these activities may need to occur within recommended avoidance timeframes. Consider that exceptions to the avoidance timeframes may be necessary and regulatory agencies may impose limits on the number of personnel and equipment redeployed during these periods.

Regulatory agency approval of work during avoidance timeframes may be necessary when restoration is delayed.

Stabilization Methods: Each plan should address mulching or the use of soil tackifiers in disturbed areas that are unable to have restoration completed. The plan should incorporate information obtained from consultations with local erosion control professionals to determine the best method for anchoring the mulch (e.g., crimping, tackifiers, etc.) under frozen conditions. Temporary seeding, as a restoration tool, should be reviewed with the regulatory agencies.

Erosion Control Devices: The construction and maintenance of erosion control devices will be a continual activity for a project. During restoration, which can be protracted due to the frozen conditions, the plan should determine a schedule and process for verify that all erosion controls are functional and how to repair the devices if necessary.

Landowners: The plan should emphasize the importance of communicating with landowners throughout frozen conditions about construction activities, construction shut downs, restoration of the right-of-way and cleanup activities timing. It is important to address their expectations for the overall timeframe for construction and restoration activities and for access across the right-of-way at all phases of construction considering that winter construction often extends the overall period of disturbance.



Drill Seeder in Upland Area

Seed Rate: To ensure adequate vegetation growth when seeding outside of the recommended seeding windows, consider seeding at a higher rate to account for lower germination success. This should be discussed with regulatory agencies, as appropriate. Additional information may be gathered from local seed supplying companies.

9.0 CONCLUSION

Frozen conditions construction offers certain opportunities and challenges. Understanding the potential issues, planning for them, and coordinating with landowners, construction contractors, agencies, and others can minimize problems during construction and restoration of the right-of-way. The guidelines presented herein focused on construction and environmental protection practices unique to frozen conditions. The intent by the INGAA Foundation in conducting this research is to assist its members with preparing for construction in frozen conditions. These guideline will assist Companies to develop project-specific plans based on each project's unique location, timing, and other variables.

Attachment A is included to provide a convenient checklist of identified items to consider in preparing the frozen conditions plan.

Attachment A

Frozen Construction Planning Guidelines Checklist

This checklist has been compiled to aid contractors and Companies on recommended measures that should be considered and adapted as appropriate when constructing under frozen conditions.

TABLE A-1		
Planning Guidelines Checklist		
	Plan Elements	Considered and addressed in plan? (Y or N or N/A)
Preconstruction Planning		
1.	Defining Frozen Conditions: Consult with the project's primary regulatory agencies on how 'frozen conditions' will be defined in each agency's permits.	
2.	Project Schedule and Timing: Incorporate project flexibility into the plan to avoid unanticipated frozen conditions during construction. Define the conditions of timing under which the plan would be implemented (i.e., specific calendar dates or certain conditions).	
3.	Communication: Develop a decision making chain for determining if work on the construction right-of-way should occur in frozen weather conditions due to changing conditions.	
Snow Removal and Storage		
1.	Advance Planning with the Landowner: Prior to construction, obtain landowner approval for extra areas off of the approved right-of-way including along access roads to allow snow storage and install temporary gates at livestock fencing crossings in accordance with landowner requirements to allow for vehicle access for snow removal activities.	
2.	Snow Removal Equipment: Use either a motor-grader, snowplow, bulldozer, or industrial blower to blade or push the snow off the access roads and right-of-way. Specify in the plan whether equipment modifications such as a 'shoe' will be used to prevent topsoil or vegetation removal.	
3.	Signage: Place proper signage for designated avoidance areas (i.e., cultural sites or special species habitat areas) in advance of frozen conditions to prevent disturbance during snow removal activities.	
4.	Snow Storage: Clearly separate snow storage from spoil storage within the right-of-way to prevent mixing. Consider the placement of stockpiled snow (i.e., drainage patterns) to ensure that snow melt will not cause erosion and/or sediment loss.	
Crossing Wetlands and Waterbodies		
1.	Frost/Ice Roads: The use of frost/ice roads provide additional equipment support during construction across wetlands and waterbodies and make environmentally sensitive areas (i.e., breeding/roosting areas for migratory birds) less susceptible to damage.	
2.	Equipment Bridges: During planning, it should be determined if equipment bridges will be removed if construction is not active in frozen conditions or if bridges are installed to not impede flow water flow during the spring thaw.	
3.	Soils: Type of soils crossed by the project should be considered. Careful preconstruction planning, which could include soil borings, will provide information to evaluate site-specific soil conditions expected during construction. Appropriate alternative techniques could be identified for use at the time of construction to limit the potential for soil mixing.	
4.	Topsoil Segregation: If snow is stockpiled over the trenchline prior to trench excavation, remove the snow to prevent the mixing of snow with the topsoil material. If a deep frost layer has formed over the trenchline, a special rock saw can be used to remove the frozen block of material which is then segregated from all other excavated materials to be used during backfilling. A rotary wheel trencher equipped with rock buckets can also be used to segregate the top 1 foot of soil into a pile, followed by a second pass to excavate the subsoil.	

TABLE A-1		
Planning Guidelines Checklist		
Plan Elements		Considered and addressed in plan? (Y or N or N/A)
5.	Open Trench or Ditch: Minimize the amount of open trench during frozen conditions to reduce the risk of freezing excavated spoil materials. One option is to limit the pace of excavation activities to the length of the ditch than can be excavated, the pipe lowered in, and fully backfilled within a specified period of time (ranging from 24 to 72 hours). Another technique used is to strip off the outer layers of a frozen soil pile and use the unfrozen inner subsoil first during backfilling.	
6.	Crowning to Mitigate Trench Subsidence: Where trench subsidence is anticipated, a crown should be constructed with native material directly over the backfilled trench and should not extend out beyond the trenchline. Monitor the trench for subsidence or excessive crowning as weather conditions improve.	
Frost Roads through Wetlands		
1.	Plan Road Development: Review wetland resources along the route and, in consultation with the jurisdictional permitting agency, plan for the need for frost roads.	
2.	Right-of-Way Clearing: Depending on project-specific conditions, wetlands with saturated soils and/or standing water require less clearing activities, whereas wetland types such as bogs, cedar swamps, and scrub-shrub wetlands may require woody vegetation clearing. Temporary equipment mats or other means may be necessary to prevent rutting during the removal of trees and woody vegetation.	
3.	Construct Temporary Frost Road: Development of the frost road should begin as soon as freezing conditions are sustained and there is sufficient enough frost or snow to support lightweight or low ground pressure equipment to begin packing the snow along the designated haul road path.	
Upland Areas		
1.	Construction Schedule: The average duration and intensity of frozen conditions in the project region should be considered early in project planning and scheduling. Long-term topsoil stockpiling to manage the topsoil and accomplish more effective seeding and restoration may be necessary after the spring thaw.	
2.	Topsoil Removal: Topsoil segregation should be completed prior to frozen soil conditions where practicable. When topsoil is frozen at the time of topsoil stripping, multiple passes (vs. a single pass) with a bulldozer or other specialized equipment (e.g., soil rippers) may be necessary to remove only the topsoil and not the subsoil.	
3.	Timing of Topsoil Restoration: Restoration should occur after both the stockpiled topsoil and exposed subsoil have thawed, the ground has dried following the spring melt, and the soils are more easily worked. During thaw periods, any travel or use of equipment over topsoil may need to be suspended to avoid soil mixing.	
Water Handling		
1.	Equipment Care: Frozen conditions can cause breakdowns in equipment. Protecting equipment from the elements especially when dewatering during freezing conditions, will ensure operations. Pumps may have to be installed in small heated shelters to prevent the pumps from freezing and or causing damage to the pumps that could result in a spill or leak of lubricants or fuel.	
2.	Discharge Rate and Volume: Dewatering activities performed during frozen conditions should be continuously monitored and adjusted as necessary. Discharge locations should be carefully evaluated and selected based on site conditions including vegetation cover, soil type, and topography.	
3.	Structure Installation and Removal: Dewatering structures (e.g., filter bags and straw bale structures) may be installed early in the construction process prior to frozen ground conditions. Dewatering structures are easiest to remove when done soon after final use. Although water-logged, the structures may not be frozen and crews can remove. Locations of the filter bags placed off the right-of-way should be marked with lathe or similar methods to assist crews in relocating the filter bag for proper disposal.	
4.	Water Appropriation: Proper planning and communication with regulatory agencies with jurisdiction over water appropriation is important to successfully complete hydrostatic testing procedures. Where testing would occur during low-flow periods, companies should discuss any appropriation volume or rate restrictions with the appropriate regulatory agencies.	

TABLE A-1

Planning Guidelines Checklist

Plan Elements	Considered and addressed in plan? (Y or N or N/A)
Temporary Erosion and Sediment Control	
1.	Installation of Temporary Erosion and Sediment Controls: Companies should review the construction right-of-way and consider installing temporary erosion and sediment controls prior to frozen ground conditions. Advance planning and placement will enable the devices to be more effective throughout construction.
2.	Winter and Spring Thaw Inspection: Companies should consider keeping an EI and environmental labor crew on site or on call through the periods of thaw to monitor erosion control structures and stabilization measures and make adjustments or repairs as necessary and as right-of-way conditions allow. The frozen conditions plan should address adequate crews to be available to conduct repairs or maintenance during thaw periods
3.	Monitoring Plan: If final cleanup and restoration activities have not occurred prior to the spring thaw, then a monitoring plan should be in place and implemented during the delay between construction and restoration or temporary shutdown of construction activities. The monitoring program should identify: erosion control structures requiring repair, areas of slope instability, and areas where significant levels of erosion are occurring.
Final Stabilization and Post-Construction Monitoring	
1.	Timing of Restoration: Determine whether the project will be completely restored or if restoration will be delayed until after the spring thaw. Backfill all areas of open excavation or provide safety fencing for protection.
2.	Stabilization Methods: The Frozen Conditions Plan should address mulching or the use of soil tackifiers in disturbed areas that are unable to have restoration completed.
3.	Erosion Control Devices: The frozen conditions plan should determine a schedule and process for verifying that all erosion controls are functional and how to repair the devices, if necessary.
4.	Landowners: Communicate with the landowners on schedule of restoration, how to report any areas of concern, and the process for post-construction monitoring during any weather shut-down periods.
5.	Seed Rate: When seeding outside of the recommended seeding windows, consider seeding at a higher rate to account for lower germination success.