

-Info-Public Service Commission

From: Andrew Perdue <aperdue@outriggerenergy.com>
Sent: Thursday, August 27, 2020 9:55 AM
To: -Info-Public Service Commission
Cc: Renfandt, Adam L.; Cody Kerrigan
Subject: Case: PU-20-247 Permits & Licenses
Attachments: NPDES General Permit NOI.pdf; OE2 North, LLC - Round Prairie TWP Crossing Permits (49th St NW - NGL and Residue Lines).pdf

CAUTION: This email originated from an outside source. Do not click links or open attachments unless you know they are safe.

Attached are the pre-construction permits & licenses, other than the PSC-issued permits, for the subject case number.

Thanks,

Andrew



Andrew Perdue

1200 Seventeenth Street | Suite 900

Denver, CO 80202

720.361.2580 direct | 720.638.7312

main

[website](#) | [email](#)



**APPLICATION (NOTICE OF INTENT) TO OBTAIN
COVERAGE UNDER NDPDES GENERAL PERMIT
FOR STORMWATER DISCHARGES ASSOCIATED
WITH CONSTRUCTION ACTIVITY (NDR10-0000)**
NORTH DAKOTA DEPARTMENT OF ENVIRONMENTAL QUALITY
DIVISION OF WATER QUALITY
SFN 19145 (06/2019)

FOR DEPT. USE ONLY

Date Received
Application Number
NOI ID: SW_NOI_20200504121303548

New Project

GENERAL INFORMATION

1. Name of Owner of Construction Project OE2 North, LLC	2. Contact First Name Russ	3. Contact Last Name Kimmitt	4. Contact Telephone Number 720.496.4068
5. Contact E-mail Address rkimmitt@outriggerenergy.com	6. Mailing Address 1200 17th Street, Suite 900		
7. City Denver	8. State/Province CO	9. Zip Code 80202	
10. Name of Operator Working at Site OE2 North, LLC	11. Contact First Name Russ	12. Contact Last Name Kimmitt	13. Contact Telephone Number 720.496.4068
14. Contact E-mail Address rkimmitt@outriggerenergy.com	15. Mailing Address 1200 17th Street, Suite 900		
16. City Denver	17. State/Province CO	18. Zip Code 80202	

PROJECT INFORMATION

19. Name of Construction Project Bill Sanderson Residue and NGL Pipelines			
20. Brief Description of Construction Activity Construction activities associated with the approximately 1.28-mile 8-inch natural gas liquids (NGLs) pipeline and an approximately 3.39-mile 20-inch residue gas pipeline, located in Williams County, North Dakota.			
21. Project Start Date 08/26/2020	22. Estimated Completion Date 12/15/2020	23. Estimated Total Acres of Site 52	24. Estimated Acres of Disturbance 52
Project Location	25. Physical Address		26. City
	27. Township	28. Range	29. Section
	30. Quarter Section (ABCD Format)		31. County Williams
Receiving Waters	32. Latitude (Decimal Degrees) 48.1255		
	33. Longitude (Decimal Degrees) -104.01521		
34. Name of Municipal Storm Sewer System or Description of Receiving Water Horse Tied Creek and/or Little Muddy Creek			

35. A SWPPP must be prepared and available for review at the time of application. You are not required to submit the SWPPP with the application unless otherwise notified by the department. The SWPPP must be completed prior to the start of construction (or the applicable construction phase). Please refer to Part I(D)(2)(c) of the permit.

<p>Submit by E-mail</p> <p>AFTER SUBMITTING BY E-MAIL PRINT AND SEND COMPLETED APPLICATION WITH "WET" INK SIGNATURE TO:</p> <p>North Dakota Dept. of Env. Quality Division of Water Quality, 4th Floor 918 East Divide Avenue Bismarck, ND 58501-1947</p> <p>Telephone: (701) 328-5210</p> <p>Print Form</p>	<p>I certify under penalty of law that I have personally examined and am familiar with the information submitted herein. Based on my inquiry of those individuals immediately responsible for obtaining the information, I believe the submitted information is true, accurate, and complete. I am aware that there are significant penalties for submitting false information including the possibility of fine and imprisonment.</p>	
	36. Printed Name of Owner(s) Russ Kimmitt	37. Title Senior Vice President and Chief Operator
	38. Signature of Owner(s) 	39. Date 8/6/2020
	40. Printed Name of Operator(s) Russ Kimmitt	41. Title Senior Vice President and Chief Operator
42. Signature of Operator(s) 	43. Date 8/6/2020	

Instructions

Submission of this application is notice that the owner(s) and operator(s) identified on the application intend to discharge stormwater associated from construction activity to waters of the state in accordance with conditions set forth in North Dakota Pollution Discharge Elimination System general permit NDR10-0000.

Permit coverage becomes effective seven (7) days after a complete application is submitted (refer to the **Submission Process** section) unless otherwise notified by the department.

General Information

1. Name of Owner of Construction Project. Enter the individual, company, organization or state who owns the property where the construction project is to take place. "Owner" means the person or party possessing the title of the land on which the construction activities will occur; or for a lease holder, the party or individual identified as the lease holder; or the contracting government agency responsible for the construction activity.

2-3. Contact Person. Provide the contact person for the owner. If the contact person is an agent of the owner, such as a consultant, provide this information on a separate page.

4. Contact Phone No. Provide a valid phone number for the contact person. Do not enter dashes or spaces.

5. E-mail Address. Provide a valid e-mail address for the contact.

6-9. Mailing Address. Provide a valid mailing address for the owner.

10. Name of Operator Working at Site (attach additional, if needed). List the operator(s) who will be responsible for the construction activities at the site. The operator is someone who has day to day supervision of construction activities and is jointly responsible with the owner for compliance with the permit conditions as they pertain to the construction activities delegated to the operator.

11-12. Contact Person Name. State the contact person who will be responsible for overseeing construction activities at the site for the operator.

13. Contact Phone No. Provide a valid phone number for the contact person. Do not enter dashes or spaces.

14. E-mail Address. Provide a valid e-mail address for the contact.

15-18. Mailing Address. Provide a valid mailing address for the operator.

Project Information

19. Name of Construction Project. Provide a descriptive, but brief, name of the construction project. Limit the name to 75 characters.

20. Brief Description of Construction Activity. Provide a brief description of the scope of work for the construction project.

21. Project Start Date. Provide the estimated project start date.

22. Project Completion Date. Provide the estimated project end date, if known. The date provided does not imply that the permit will expire on the projected end date. The permit will be terminated only after a notice of termination is submitted to the department.

23. Estimated Total Area of Site. Enter the estimated acreage of the site/property in acres.

24. Estimated Area of Disturbance. Enter the estimated total acreage of land to be disturbed by construction activity.

25. Physical Address. Enter a physical address if one is available. For residential construction, do not use a recorded plat survey, such as lot and block number. If a street address is not available, please use an alternative project location description (boxes 27 through 33).

26. City. Enter city in which project is located. If the project is located in a rural area, enter the nearest city.

27-30. Township, Range, Section, Quarter Section. Provide the numerical township, range and section of the construction project. Provide the quarter section in the ABCD format. See image in next column.

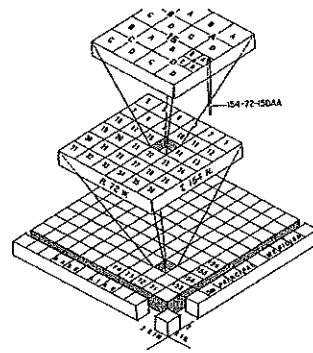

31. County. Provide the county in which the project is occurring.

32-33. Latitude and Longitude. Provide the latitude and longitude in decimal degrees at the center of the site.

34. Municipal Storm Sewer System or Description of Receiving Water. If the project is located within city limits, enter the name of the city along with receiving water of the city storm sewer. Provide the name of the receiving body of water if outside city limits (e.g. Red River, unnamed tributary to Cherry Creek, wetlands, etc.).

Stormwater Pollution Prevention Plan (SWPPP) Requirements

35. As part of the permit, a SWPPP must be developed and available for review at the time of application. You are not required to submit the SWPPP with the application unless otherwise notified by the department. The SWPPP must be completed prior to the start of construction (or the applicable construction phase). Please refer to Part I(D)(2)(c) of the permit.

Signature Information

36-39. Owner Information. The signatory must be a responsible corporate officer, general partner, principal executive officer, or ranking elected official as required in Part IV(6)(a) of the permit number NDR10-0000.

40-43. Operator Information. The signatory must be a responsible corporate officer, general partner, principal executive officer, or ranking elected official as required in Part IV(6)(a) of the permit number NDR10-0000.

Submission Process

Click on the "New Project" button if this is a new project being submitted for permit coverage. Once the data fields are filled out, click the "Submit by E-mail" button. This will create an email and attach a xml document to the email. The xml document contains the information entered into each field of the application. To assist with faster processing, please copy and paste the NOI ID into the email subject line of your email.

After the e-mail has been sent, print a paper copy of the application, sign and **submit the original copy with the "wet" signature** to the department. Failure to do so is considered a violation.

THE ELECTRONIC APPLICATION MUST BE SUBMITTED FIRST. Paper applications which are received prior to the electronic application being received will be returned. Permit coverage will not be obtained until the electronic application can be paired with a paper application utilizing the NOI ID on the top right of the form. **Note: THE NOI ID IS NOT THE PERMIT COVERAGE NUMBER.**

A copy of the NOI may be saved and the NOI ID will remain the same as the submitted NOI. To submit an NOI for a new project, click on the new NOI ID button, update the project information and save as a new file name.

**ROUND PRAIRIE TOWNSHIP
ROAD CROSSING PERMIT**

PERMIT NO. 45

**TOWNSHIP ROAD CROSSING PERMIT
FEE - \$250.00 PER PERMIT**

The Round Prairie Township Board, or its representative, hereby grants permission to

OE2 North, LLC whose address is 1200 Seventeenth Street, Suite 900, Denver, CO 80202, to

bore a pipeline through the Township road driving surface and across the drainage ditches and right-of-way of the graded gravel road (49th Street NW) located between the following Sections, Township and Range:

T154N - R103W Section 26: SESE

to

T154N - R103W Section 35: NENE

Applicant shall be responsible to leave site in the same condition as before crossing was made and repair any damages resulting from its crossing.

Should it be necessary for road improvement purposes, Applicant shall promptly remove said facilities from Township right-of-way, or shall relocate and adjust said facilities, at its sole cost and expense when requested to do so by the Board. The Township shall not be held liable for damage to said facilities located within the public right-of-way resulting from reconstruction or maintenance of the highway.

Applicant shall mark crossing site with post and sign on each side of roadway.

No pipeline work across graded, graveled Township roads shall begin until both and or all parties involved have signed the necessary paperwork and returned the signed papers to each other.

All North Dakota Century Codes shall be followed.

**Please notify Township when work will start and finish
701.875.4207 or 701.875.4278. The contractor MUST have a
copy of the permit and the cross section at all times.**

Applicant - OE2 North, LLC

By

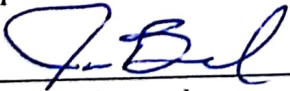
Josh Bond, Landman on behalf of
OE2 North, LLC
701-269-8559

Round Prairie Township

By

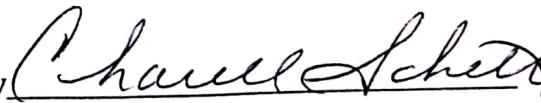
Township Representative

ROUND PRAIRIE TOWNSHIP ROAD CROSSING PERMIT

PERMIT NO. _____

TOWNSHIP ROAD CROSSING PERMIT FEE - \$250.00 PER PERMIT

The Round Prairie Township Board, or its representative, hereby grants permission to

OE2 North, LLC whose address is 1200 Seventeenth Street, Suite 900, Denver, CO 80202, to

bore a pipeline through the Township road driving surface and across the drainage ditches and right-of-way of the graded gravel road (49th Street NW) located between the following Sections, Township Range:

T154N - R103W Section 26: SESE

to

T154N - R103W Section 35: NENE

Applicant shall be responsible to leave site in the same condition as before crossing was made and any damages resulting from its crossing.

Should it be necessary for road improvement purposes, Applicant shall promptly remove said facilities from Township right-of-way, or shall relocate and adjust said facilities, at its sole cost and expense as requested to do so by the Board. The Township shall not be held liable for damage to said facilities located within the public right-of-way resulting from reconstruction or maintenance of the highway.

Applicant shall mark crossing site with post and sign on each side of roadway.

No pipeline work across graded, graveled Township roads shall begin until both and or all parties involved have signed the necessary paperwork and returned the signed papers to each other.

All North Dakota Century Codes shall be followed.

Please notify Township when work will start and finish 701.875.4207 or 701.875.4278. The contractor MUST have a copy of the permit and the cross section at all times.

Applicant - OE2 North, LLC

By _____

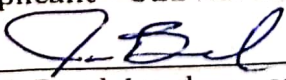
Josh Bond, Landman on behalf of
OE2 North, LLC
701-269-8559

Round Prairie Township

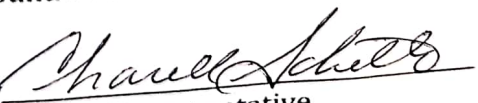
By 
Township Representative

Section 25
T154N-R104W

Section 36
T154N-R104W

154th Avenue NW
BEGINNING OF BORE
X=1110307.51
Y=430289.93
LAT=N048.12591645
LONG=W104.01521530





ENDING OF BORE
X=1110301.59
Y=430158.61
LAT=N048.12555611
LONG=W104.01521499

Section 26
T154N-R104W

49th Street NW

Section 35
T154N-R104W

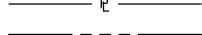
Legend

-  Additional Temporary Workspace
-  Proposed Easement
-  Gas Pipeline
-  Property Line
-  Section Line



NTB Associates, Inc.
Surveyors

525 Louisiana Ave
Shreveport, LA 71101
Phone: (318) 226-9199 Fax: (318) 221-1208
Firm Registration No.: F-955 Exp. 09/30/2020

OE2 NORTH - 49TH STREET CROSSING
PROPOSED 50' NATURAL GAS PIPELINE EASEMENT
Located in Section 26 & 35, T154N - R104W
NORTH DAKOTA

Section 25
T154N-R104W

Section 36
T154N-R104W

154th Avenue NW

BEGINNING OF BORE
X=1110297.52
Y=430290.36
LAT=N048.12591638
LONG=W104.01525624



ENDING OF BORE
X=1110291.59
Y=430159.04
LAT=N048.12555603
LONG=W104.01525593

Section 26
T154N-R104W

49th Street NW

Section 35
T154N-R104W

Legend

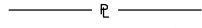
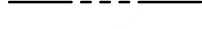
-  Additional Temporary Workspace
-  Proposed Easement
-  Gas Pipeline
-  Property Line
-  Section Line



NTB Associates, Inc.
Surveyors

525 Louisiana Ave
Shreveport, LA 71101
Phone: (318) 226-9199 Fax: (318) 221-1208
Firm Registration No.: F-955 Exp. 09/30/2020

OE2 NORTH - 49TH STREET CROSSING
PROPOSED 50' RESIDUE PIPELINE EASEMENT
Located in Section 26 & 35, T154N - R104W
NORTH DAKOTA